

**BHUTAN POWER CORPORATION LIMITED  
PROCUREMENT SERVICES DEPARTMENT  
THIMPHU: BHUTAN**



**(Tender No. BPC/PSD/TU/ERW Pipe/2011/16 dated 15<sup>th</sup> December 2011)**

**BID DOCUMENT**

**FOR**

**The Supply and Delivery of ERW Steel Penstock**

December 2011



འབྲུག་གྲོག་མེ་ལས་འཛིན།

**Bhutan Power Corporation Limited**  
**Procurement Services Department**  
**Thimphu: Bhutan**



**INVITATION TO BID**

Bhutan Power Corporation Limited would like to invite the sealed bids from the authorized suppliers / dealers / manufacturers with valid trade license for supply and delivery of ERW Steel Penstock for Thimphu Hydel.

SI #	Item	Remark	
1.	Tender No. & date	BPC/PSD/TU/ERW Pipe/2011/16 dated 15/12/ 2011	
2.	Item Descriptions	ERW Steel Penstock.	
3.	Bid Details: a) Date of submission: b) Place of submission: c) Opening Date: d) Place of Opening:	17 <sup>th</sup> January 2012 till 15:00 hours PSD, BPC, Thimphu 17 <sup>th</sup> January 2012 at 15:30 hours BPC Conference Hall, Thimphu	
4.	Bid Security (EMD)	ERW Steel Penstock	Nu. 8,500.00

Bidding document can be downloaded from BPC website ([www.bpc.bt](http://www.bpc.bt)) or soft copy can be obtained from Mrs. Ku Karma (email id – [k\\_karma@bpc.bt](mailto:k_karma@bpc.bt)) from PSD Office during working hours starting from 19<sup>th</sup> December 2011 for free.

**General Manager**  
**Procurement Services Department**

## CHECKLIST FOR BID SUBMISSION

SL#	PARTICULARS	Purchasers Requirement	Bidders Submission	
			YES	NO
1	Valid trade license	YES		
2	Signed and dated bid form	YES		
3	EMD drawn in favor of Chief Finance Officer, FAD, BPC, Thimphu, Bhutan.	YES		
4	Price Schedule	YES		
5	Signed GTPs	YES		
6	Manufacturer's Authorization	YES		
7	Power of Attorney	YES		
8	Signed VPMS form	YES		
9	Signed Pre contract Integrity pact	YES		

**TENDER NO:** BPC/PSD/TU/ERW Pipe/2011/16  
**DATE:** December 15, 2011  
**WORK:** Supply and Delivery of ERW Steel Penstock.

**CONTENTS OF THE BID DOCUMENT**

<b>SI #</b>	<b>Section</b>	<b>Title</b>	<b>Page No.</b>
1	-	Invitation to Bid	2
2	-	Checklist for bid submission	3
3	Section I	Terms and Conditions	5-8
4	Section II	Technical Specifications and Drawings, Guaranteed Technical Particulars &	9-12
5	Section III	Forms and Price Schedule:	
		(i) Bid Form	14-15
		(ii) Power of Attorney Form	16
		(iii) VPMS Pact	17
		(iv) Pre-contract Integrity Pact	18-22
		(v) Guaranteed Technical Particulars	23
		(vi) Schedule of Non-compliance	24
		(vii) Price Schedule	25

## SECTION I

### TERMS AND CONDITIONS

The invitation for Bids is open to all Manufacturers/Export Houses/Authorized Dealers from outside Bhutan and to Authorized Dealers/National Suppliers licensed under Ministry of Economic Affairs of royal Government of Bhutan (Supporting evidence to corroborate the claim must be enclosed). The following are the terms and conditions:

#### 1. Definitions

- a) Purchaser – The Procurement Services Department, Bhutan Power Corporation Limited (BPC), Thimphu (hereinafter referred to as “**The Purchaser**”).
- b) Supplier – The Bidder (hereinafter referred to as “**The Supplier**”).
- c) Goods – Supply and Delivery of ERW Steel Penstock described in Section III hereof (hereinafter referred to as “**The Goods**”).

#### 2. BID SUBMISSION

The deadline for Bid submission is on 17<sup>th</sup> January 2012, 1500 hrs and shall be opened on the same day at 1530 hrs.

#### 3. PRICES

Fixed price for delivery CIP, Regional Store Division, Bhutan Power Corporation Limited, Phuentsholing, Bhutan.

#### 4. BID SECURITY

**4.1** A bid security of Nu.8,500.00 (Ngultrum eight thousand five hundred) in the form of bank guarantee/ cash warrant/ demand draft issued by a reputable bank acceptable to the purchaser should be provided to be responsive.

**4.2** The bid security shall be valid for 120 days after the date of tender opening (i.e. valid up to 16<sup>th</sup> May 2012) this shall be drawn in favor of Chief Finance Officer, FAS, BPC, Thimphu.

**4.3** Any Bid not secured in accordance with Clause 4.1 and 4.2 above shall be rejected by the Purchaser as non-responsive.

**4.5** An unsuccessful Bidder's bid security will be discharged/returned as promptly as possible upon award of Contract, but in any event not later than thirty (30) days after the expiration of the period of bid validity prescribed by the Purchaser, pursuant to Clause 5.

**4.6** The successful bidder's bid security will be discharged/returned upon furnishing the performance security and the bidder's executing the Contract.

#### 4.7 The bid security may be forfeited:

- (a) If a bidder withdraws its Bid during the period of bid validity specified by the bidder on the Bid Form; or
- (b) In the case of a successful bidder, if the bidder fails
  - (i) To sign the Contract or
  - (ii) To furnish the performance security in accordance with Clause 7.

### 5. BID VALIDITY

The bid shall remain valid for 90 days from the date of bid opening up to 16<sup>th</sup> April 2012. *A bid valid for a shorter period shall be rejected by the Purchaser as nonresponsive.*

### 6. CONSIGNEE

CIP: Manager, Regional Stores Division, Bhutan Power Corporation Limited, Phuentsholing, Bhutan.

### 7. PERFORMANCE SECURITY

The 10% performance security shall be furnished by the successful bidder in the form of demand draft/cash warrant/bank guarantee issued by the bank acceptable to the purchaser at the time of signing the contract. The performance security should be valid for one year from the complete delivery of materials.

The proceeds of the performance security shall be payable to the purchaser as compensation for any loss resulting from the supplier's failure to complete its work under the contract.

### 8. WARRANTY

The supplier warrants to the purchaser that the goods supplied under the contract will comply strictly with contract shall be first class in every particular case and shall be free from defects. The supplier further warrants to the purchaser that the material provided by the supplier will be new and fit for their intended purposes.

This Warranty shall remain valid for six (6) months after the Goods, or any portion thereof, as the case may be, have been delivered and commissioned. As a proof of performance warranty, the Purchaser will not release the 10% performance security for a period of not exceeding six (6) months after the complete delivery of the Goods.

### 9. DELIVERY

**The delivery of the materials shall be made within 90 days from the issue of supply order.** Bids offering the late delivery schedule (LDS) will be accepted but the bids shall be adjusted for the purpose of bid evaluation only adding @ (rate of) one (1) percent of the bid price for each week of delay to the bid price. Bids offering delivery schedules beyond two months of the delivery period will be rejected.

## **10. PAYMENT**

100% payment shall be made against the delivery of the materials within 30 (Thirty) days after submission of an invoice or claim by the Supplier giving the full particulars of the materials supplied.

## **11. TAXES and DUTIES**

The supplier shall be entirely responsible for all taxes, stamp duties and other such levies imposed both inside and outside the purchaser's country.

## **12. FORCE MAJEURE**

In the event that the supplier or any of its subcontractors or the purchaser is delayed in performing any of their respective obligations under the contract, and such delay is caused by force majeure, including but not limited to war, civil insurrection, fires, floods, epidemics, earthquakes, quarantine restrictions and freight embargoes, such delay may be excused and the period of such delay may be added to the time of performance of the obligation delayed. If a force majeure situation arises, the supplier shall promptly notify the Purchaser in writing of such condition and the cause thereof within 10 days. Unless otherwise directed by the purchaser in writing, the supplier shall continue to perform its obligations under the contract as far as is reasonably practical, and shall seek all reasonable alternative means for performance not prevented by the force majeure event.

## **13. LIQUIDATED DAMAGE**

Subject to force majeure, if the supplier fails to deliver any or all of the goods within the period(s) specified, the purchaser shall without any prejudice to its other remedies under the contract, deduct from the contract price, as liquidated damages, a sum equivalent to one (1) percentage per week on prorated basis of delivered price of the delayed goods or unperformed services for each week or part thereof of delay until actual delivery of performance, up to a maximum of ten (10) percent of the total contract price.

## **14. TERMINATION FOR DEFAULT**

The purchaser may, without any prejudice to any other remedy for breach of Contract, by written notice of default sent to the supplier, terminate the contract in whole or part (a) if the supplier fails to deliver any or all within the time period (s) specified in the Contract, or any extension thereof granted by the purchaser or (b) if the supplier fails to perform any other obligation(s) under the contract.

## **15. DISPUTE RESOLUTION**

The purchaser and the supplier shall make every effort to resolve amicably by direct informal negotiation any disagreement or dispute arising between them under or in connection with the contract. If, after 30 (thirty) days from the commencement of such informal negotiations, the purchaser and the supplier have been unable to resolve amicably a contract dispute, either party may require that the dispute be referred for resolution in the court.

## **16. PRE CONTRACT INTEGRITY PACT**

The Bidders are as a condition of admission to eligibility, execute and attach to their bids an Integrity Pact Statement in the form provided in Annexure-II. Failure to provide a duly executed Integrity Pact Statement shall result in disqualification of the Bid.

## **17. VENDOR PERFORMANCE MANAGEMENT SYSTEM (VPMS)**

The performance of the vendor shall be assessed as per the guides contained in the Vendor Performance Management System available in the BPC website ([www.bpc.bt](http://www.bpc.bt)) for the purpose of determining the eligibility in participating in future tenders.

The VPMS Acceptance form is provided in Annexure- II. The bidders are required to sign VPMS Acceptance form agreeing to applicability of VPMS and be endorsed with the bid. In case if the VPMS is not signed, the bid shall be rejected.

## **18. Guaranteed Technical Particulars (GTP)**

Those bids whose GTPs are not filled shall be rejected by the supplier as non responsive.

**(General Manager)**

## SECTION II

### TECHNICAL SPECIFICATION OF ERW (ELECTRIC RESISTANCE WELDING) STEEL PENSTOCK

#### 1.0 General

This specification represents the minimum requirements. The Supplier shall provide the steel pipe, which meets or exceeds these minimum requirements.

These items are being sought as additions to existing system. Therefore, it is essential to maintain compatibility with existing Pipes.

#### 1.1 Scope

This specification covers the manufacture, testing, supply, delivery and performance requirements of penstock (ERW Steel Pipe). The penstock pipe is intended to be used for replacement of old penstock pipe for 125 kW Hydel in Thimphu, Bhutan.

#### 2.0 Standards

The materials shall comply with IS: 2026 of 2006, the latest editions of and amendments to the international and Indian standards. Where any provision of this specification differs from those of the standards listed hereafter, the provision of this specification shall apply.

##### IS - Indian Standards

- i) IS 2062 of 2006: Steel for general structural purposes

##### Note:

In case of conflict, the order of precedence shall be:

- i) This Specification
- ii) IS Standards
- iii) Other Standards

Alternative Standards may be approved, provided the Supplier demonstrates that they give a degree of quality and performance equivalent to that of the referenced Standards. Acceptability of any alternative Standard is at the discretion of the Purchaser.

The manufacturer must operate a quality assurance system that complies with ISO 9000. The Supplier shall provide current certification showing the manufacturers' compliance with ISO 9000 or equivalent national standard. The certificate must be issued by an independent, accredited issuing authority.

#### 3.0 Pipe Dimensions for single length (subject to tolerances)

The length shall be	– 6000 mm
The outer diameter shall be	– 222.8170 mm
The internal diameter	– 210.2170 mm
Sheet thickness shall be	– 6.30 mm

## **4.0 Construction of Pipes (Penstock)**

### **4.1 Material**

The pipes shall be made from longitudinally welded tube sections of hot rolled structural carbon steel in accordance with the Standards quoted in this Specification, or with any equivalent Standard, which the Purchaser has approved.

Pipes shall be made from steel Grade C, E250 (Fe 410W) having the mechanical strength properties as follows:

- i) Tensile strength: 410 Mpa
- ii) Yield strength: 250 Mpa

### **4.2 Chemical Requirements**

The material of the steel shall be of grade A with the following chemical contents:

- i) C % – 0.20% max
- ii) Mn – 1.50% max
- iii) P – 0.04% max
- iv) S – 0.04% max
- v) Si – 0.04% max
- vi) Carbon Equivalent – 0.39

### **4.3 Manufacturing**

The pipe shall be made by bending the steel plate uniformly through an automated process. A hammer shall not be used for edge bending.

### **4.4 Coating**

After manufacture, all pipes shall be painted for protection against corrosion.

- i) A steel penstock shall be coated in accordance with the specifications that is most suitable for the installation environment and shall ensure enough durability.
- ii) Prior to coating, rust, oil, grease and dust on the surface of a steel penstock shall be carefully removed and cleaned, then the surface shall be thoroughly dried. It is desirable that alkaline fume deposited on a weld line or its adjacent place by a low hydrogen type electrode be removed.
- iii) Coating shall be avoided in an excessive hot or cold temperature or when humidity is high, or when rainfall or snowfall may be forecast before the paint gets dried, or other cases, e.g. when coating cannot be made properly.
- iv) On both of internal and external surface of a steel penstock tar-epoxy resin paint (brown color) shall be used. Minimum thickness of the paint film shall be set at 0.4mm.

## 5.0 List of Test:

The following test shall be carried out on the samples drawn from each consignment of the pipes:

- i) Chemical test for the steel (raw materials) as per relevant IS.
- ii) Bend test, Tensile test and impact test as per relevant IS.

## 6.0 Marking on pipes

- i) Name/brand of Manufacture.
- ii) Grade of pipe.
- iii) Diameter & length of pipe.

## 7.0 Retest:

All the samples subjected to above tests shall pass the tests. Should one or more number of sample fail in any of the test, a second set of samples, double in number shall be drawn and subjected to above tests. Should one or more number of sample from second set of sample fail in any of the tests, the entire consignment shall be rejected.

## 8.0 Tolerances

- i) On length :  $\pm 1\%$  on overall length shall be allowed.
- ii) On thickness :  $\pm 5\%$
- iii) On weight :  $\pm 2.5\%$  on the individual weight.

In case of negative tolerance on the weight of the pipe, the payment shall be prorated for the reduction in weight from the standard weight based on the actual weight of the Lot. The actual payment will be based on the following.

- i) Payment as per contract rates =  $R \times N$
- ii) Less reduction for lower weight =  $R \times N \times \{ (W_s - W_a) / W_s \}$
- iii) Actual Eligible Payment =  $R \times N \times (W_a / W_s)$

Where:

R is the rate per pipe in the contract

N is the no. of pipes in the LOT

$W_s = N \times W$ , where W is the standard weight per pipe

$W_a$  = Actual weight of the LOT

### Technical Particulars for ERW Steel Penstock

Sl. #	Description	Unit	Technical Specifications
1.	Applicable standard		IS: 2062 of 2002
2.	Materials		Steel grade C, E250 (Fe 410 W)
3.	Tensile Strength		410 Mpa
4.	Yield strength		250 Mpa
5.	IS-Standards		IS:2062 of 2002
6.	Chemical contents:		
	i) C%		0.20% max
	ii) Mn %		1.50% max
	iii) P %		0.04% max
	iv) S %		0.04% max
	v) Si %		0.04% max
	vi) Carbon Equivalent		0.39
7.	Flange details:		
	i) External Diameter		343.7800 mm
	ii) Thickness		8.00 mm
	iii) No. of Nuts & Bolts		8 nos.
8.	Coupling Details:		
	i) Thickness		6.00 mm
	ii) No. of Nuts & Bolts		5 nos.
9.	Pipe Dimensions for single length:-		
	i) Length		6000 mm
	ii) Outer Diameter		222.8170 mm
	iii) Internal Diameter		210.2170 mm
	iv) Circumference		700 mm
	v) Sheet Thickness		6.3 mm
10.	Tolerance:		
	i) On length		± 1%
	ii) On thickness		± 5%
	iii) On weight		± 2.5%

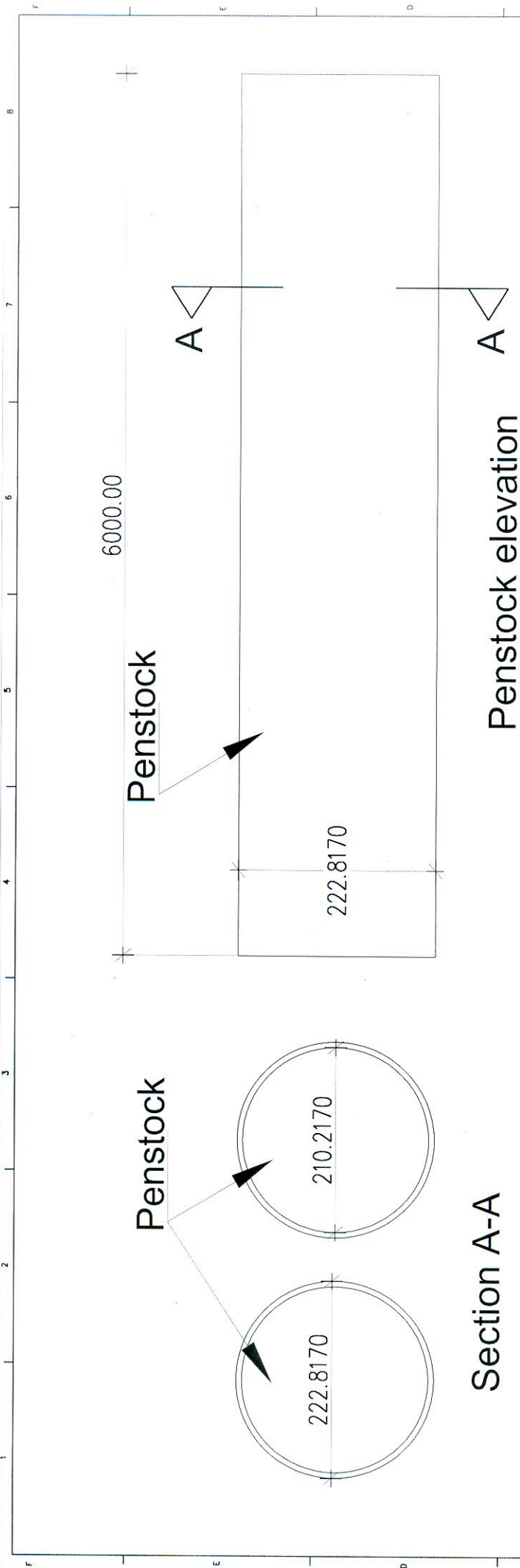

### Pipe Dimension for single length:

- Length = 6000mm
- External Diameter = 222.8170 mm
- Internal Diameter = 210.2170 mm
- Thickness of the penstock = 6.3 mm
- Circumference = 700 mm

<b>PROJECT :</b> DETAIL DRAWINGS OF PENSTOCK BIFURCATION PIPES FOR THIMPHU MINI HYDEL.	DRAWING TITLE		AS STATED		 BHUTAN POWER CORPORATION LTD. CIVIL WORKS DIVISION	CLIENT	PSD	DRAWN BY:  BHARUN GIRI (CIVIL ENGG.)	APPROVED BY:  S.E. CMD	NOTE All dimensions are in mm unless otherwise specified. Dimensions are to be read as indicated. Any discrepancies in the drawing shall be the responsibility of the consultant for timely rectification.	DATE	REVISION	DATE
	30/11/2011		SCALE	NTS							DRG NO. PS-03		

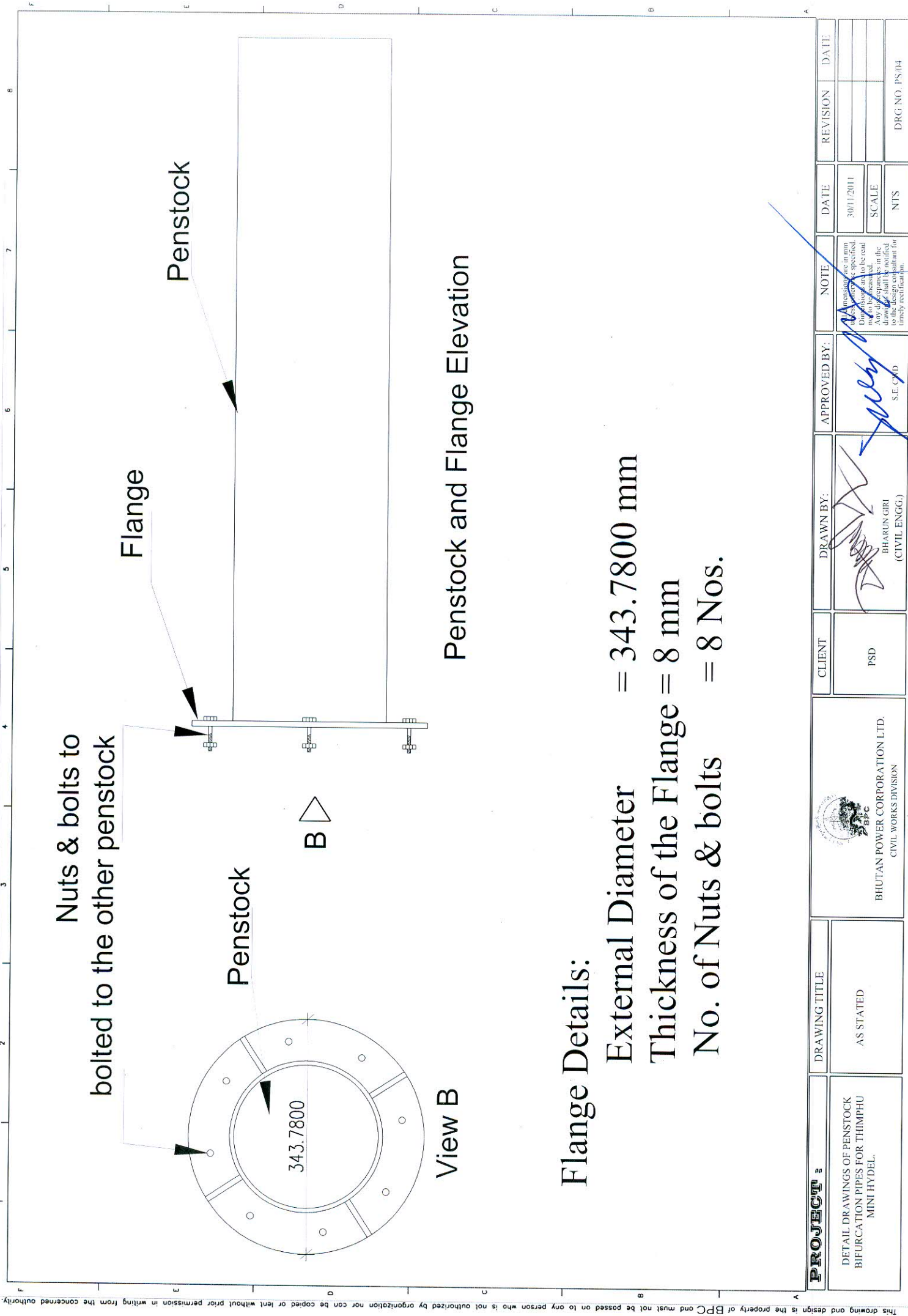

Penstock and Flange Elevation

Flange Details:

- External Diameter = 343.7800 mm
- Thickness of the Flange = 8 mm
- No. of Nuts & bolts = 8 Nos.

<b>PROJECT :</b>		DRAWING TITLE		CLIENT		APPROVED BY:		NOTE		DATE		REVISION		DATE	
DETAIL DRAWINGS OF PENSTOCK BIFURCATION PIPES FOR THIMPHU MINI HYDEL.		AS STATED		PSD		 BHARUN GIRI (CIVIL ENGG.)		All dimensions are in mm unless otherwise specified. Dimensions are to be read as shown and to be read as shown. Any discrepancies in the drawing shall be notified to the client for timely rectification.		30/11/2011					
						 S.E. G.D.				SCALE				DRG NO. PS/04	
										NITS					

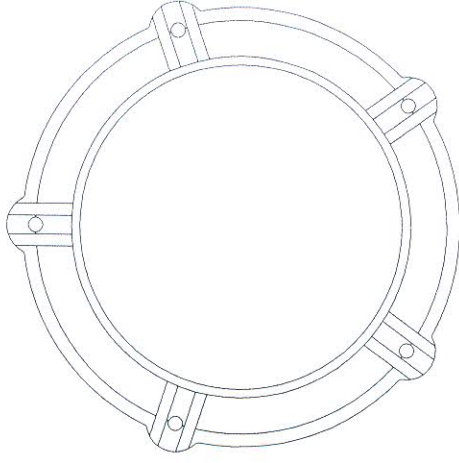
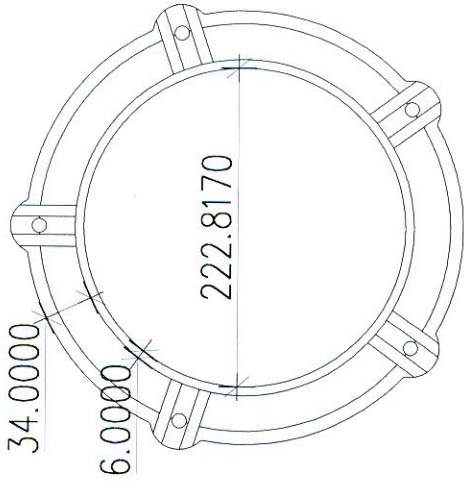
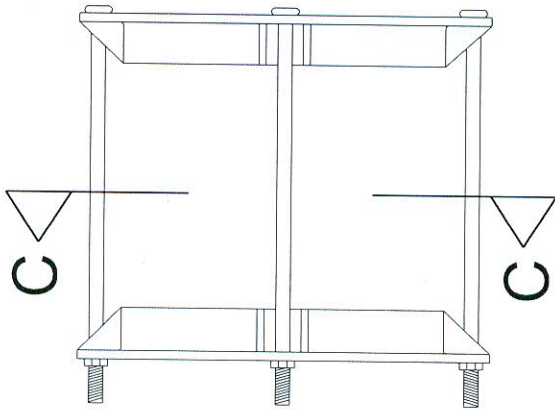

Top View of the Coupling

Section C-C

### Coupling Details:

Thickness of the Coupling = 6 mm

No. of Nuts & bolts = 5 Nos.

**PROJECT :**

DETAIL DRAWINGS OF PENSTOCK  
BIFURCATION PIPES FOR THIMPHU  
MINI HYDEL.

**DRAWING TITLE**

AS STATED

**CLIENT**

PSD

**DRAWN BY:**

BHARUN GIRI  
(CIVIL ENGG.)

**APPROVED BY:**

S.E. CWB

**NOTE**

Dimensions are in mm and shall be rounded off to the nearest mm. Dimensions are to be read as shown. Any discrepancies in the drawings shall be notified to the design consultant for timely rectification.

**DATE**

30/11/2011

**REVISION**

SCALE

**DATE**

NTS

DRG NO. PS-05

## **SECTION III**

### **FORMS AND PRICE SCHEDULE**

- 1. Bid Form**
- 2. Power of Attorney**
- 3. VPMS Form**
- 4. Pre contract Integrity Pact**
- 5. Schedule of Guaranteed Technical Particulars**
- 6. Deviation Form**
- 7. Price Schedule**

**Form 1**

*Bid Form*

General Manager,  
Procurement Services Department,  
Bhutan Power Corporation Limited,  
Thimphu: Bhutan.

Sir,

Having examined the Bidding Documents for the above Contract, including the Specifications, the receipt of which is hereby duly acknowledged, we the undersigned, offer to supply and deliver .....(Description of Goods) in conformity with the said Bidding Documents, including Addenda Nos..... (Insert Numbers), for the sum of ..... (Total Bid Amount CIF/CIP in Words and Figures) or such other sums as may be ascertained in accordance with the Price Schedules attached hereto and made part of this Bid.

We undertake, if our Bid is accepted, to commence delivery within ..... days, and to complete delivery of all the items specified in the Contract within ..... days, calculated from the date of receipt of your Notification of Award and in accordance with the Contract Execution Schedule provided in the Special Conditions of Contract.

If our Bid is accepted, we will provide the performance security in the sum of ..... (Amount), equal to (10%) seven percent of the Contract rate, for the due performance of the Contract.

We agree to abide by this Bid for the period of **90** days from the date fixed for bid closing pursuant to Clause 13 of the Instructions to Bidders, and it shall remain binding upon us and may be accepted at any time before the expiration of that period.

Until a formal Contract is prepared and executed, this Bid, together with your written acceptance thereof in your Notification of Award, shall constitute a binding contract between us.

We understand that you are not bound to accept the lowest-priced or any Bid that you may receive.

Dated this \_\_\_\_\_ day of \_\_\_\_\_ 2011

\_\_\_\_\_  
(Signature)

\_\_\_\_\_  
(In the Capacity of)

Duly authorized to sign Bid for and on behalf of \_\_\_\_\_  
\_\_\_\_\_

\_\_\_\_\_  
(Signature of Witness)

Witness \_\_\_\_\_

Address \_\_\_\_\_

**Form 2**

**1. POWER OF ATTORNEY FORM**

By this Power of attorney, created on.....(date), (name of manufacturer/supplier/firm/dealer), having its legal domicile in (Place, Country), hereby nominates, constitutes and appoints as its true and lawful attorney.

(Name of Signatory Authority).

Who is given the authority to bind the firm by his signature in matters connected with or related to the company's activities in the supply and delivery of electrical materials for Power Lines and Substations for Bhutan power Corporation Limited

This Power of Attorney shall remain in force until.....(Date).....

\_\_\_\_\_  
Signature of Signatory Authority  
Name:  
Designation:

\_\_\_\_\_  
Signature of Authorized  
Licensee of the firm.  
Name:

**Form 3**

**VPMS ACCEPTANCE FORM**

**Annex- I1**

*[The Bidder shall fill in this form in accordance with the instructions indicated. No alterations to its format shall be permitted and no substitutions shall be accepted.] The Vendor Performance Management System document is available on the BPC website (www.bpc.bt)*

WHEREAS MESSRS \_\_\_\_\_ -- \_\_\_\_\_ (Hereinafter called "the Bidder") License No. \_\_\_\_\_ having our registered office at \_\_\_\_\_ has submitted its bid dated \_\_\_\_\_.

We hereby agree to abide by the Vendor Performance Management System of BPC or do affirm as follows.

- a) We have read and understood all provisions set in the Vendor Performance Management System (VPMS) and we have no reservations to the VPMS document included in the Bidding Documents.
- b) We agree to abide by all the provision of VPMS.
- c) If our bid is accepted, we agree to be assessed as per the vendor rating methodology adopted by Bhutan Power Corporation Limited.
- d) Depending on our performance, we accept the rating of Vendor Performance Index issued and any action taken as deemed necessary by Bhutan Power Corporation Limited.
- e) We shall be liable for any breach of this undertaking and non- compliance to the provisions of VPMS.

**Incuse if the pact is not signed, the bid shall be rejected**

**Legal Stamp (Signature)**

**Witness (complete address & Signature)**

Date:

Place:

<b>2. PRE CONTRACT INTEGRITY PACT</b>	
<b>1</b>	<p><b>General</b></p> <p>Whereas the <u>Pradeep M. Pradhan, General Manager</u> representing the <u>Procurement Services Department of Bhutan Power Corporation Limited</u>, the Royal Government of Bhutan, hereinafter referred to as the Employer on part and the ..... as the other part hereby execute this agreement as follows.</p> <p><b>This agreement should be a part of the tender document, which shall be signed when the work(s) is awarded. Signing authorities will be the head of the client (agency) and the authorized representative of the bidder. If the winning bidder fails to sign the agreement, the work shall be cancelled.</b></p>
<b>2</b>	<p><b>Objectives</b></p> <p>Now, therefore, the Employer and the bidder agree to enter into this pre-contract agreement, hereinafter referred to as Integrity Pact, to avoid all forms of corruption by following a system that is fair, transparent and free from any influence/unprejudiced dealings prior to , during and subsequent to the currency of the contract to be entered into with a view to:-</p> <p>2.1 Enabling the Employer to obtain the desired works at a reasonable and competitive price in conformity with the defined specifications of the goods and services;</p> <p>2.2 Enabling bidders to abstain from bribing or any corrupt practice in order to secure the contract by providing assurance to them that their competitors will also refrain from bribing and other corrupt practices and the Employer will commit to prevent corruption, in any form by their officials by following transparent procedures.</p>
<b>3</b>	<p><b>Commitments of the Employer:</b></p> <p>The Employer commits itself to the following:-</p> <p>3.1 The Employer undertakes that no official of the Employer, connected directly or indirectly with the contract, will demand, take a promise for or accept, directly or through intermediaries, any bribe, consideration, gift, reward, favor or any material or immaterial benefit or any other advantage from t he Bidder, either for themselves or for any person, organizing or third party related to the contract in exchange for an advantage in the bidding process, bid evaluation, contracting or implementation process related to the Contract.</p> <p>3.2 The Employer will, during the pre-contract stage, treat all Bidders alike, and will provide to all Bidders the same information and will not provide any such information to any particular Bidder which could afford an advantage to that particular Bidder in comparison to other Bidders.</p>

3.3 All the officials of the Employer will report to the appropriate Government office any attempted or completed breaches of the above commitments as well as any substantial suspicion of such a breach.

3.4 In case of any such preceding misconduct on the part of such official(s) is reported by the Bidder to the Employer with full and verifiable facts and the same is prima facie found to be correct by the Employer, necessary disciplinary proceedings, or any other action as deemed fit, including criminal proceedings may be initiated by the Employer and such a person shall be debarred from further dealings related to the contract process. In such a case while an enquiry is being conducted by the Employer the proceedings under the contract would be not be stalled.

#### **4 Commitments of Bidders**

The bidder commits himself to take all measures necessary to prevent corrupt practices, unfair means and illegal activities during any stage of his bid or during any pre-contract or post-contract stage in order to secure the contract or in furtherance to secure it and in particular commits himself to the following:-

4.1 The Bidder will not offer, directly or through intermediaries, any bribe, gift, consideration, reward favor, any material or immaterial benefit or other advantage, commission, fees, brokerage or inducement to any official of the Employer, connected directly or indirectly with the bidding process, or to any person, organization or third party related to the contract in exchange for any advantage in the bidding, evaluation, contracting and implementation of the contract.

4.2 The Bidder further undertakes that he has not given, offered or promised to give, directly or indirectly any bribe, gift, consideration, reward, favor, any material or immaterial benefit or other advantage, commission, fees, brokerage or inducement to any official of the Employer or otherwise in procuring the Contract or forbearing to do or having done any act in relation to the obtaining or execution of the Contract or any other contract with the Government for showing or forbearing to show favor or disfavor to any person in relation to the Contract or any other contract with the Government.

4.3 The Bidder will not collude with other parties interested in the contract to preclude the competitive bid price, impair the transparency, fairness and progress of the bidding process, bid evaluation, contracting and implementation of the contract.

4.4 The Bidder, either while presenting the bid or during pre-contract negotiations or before signing the contract, shall disclose any payments he has made, is committed to or intends to make to officials of the Employer of their family members, agents, brokers or any other intermediaries in connection with the contract and the details of services agreed upon for such payments.

4.5 The Bidder commits to refrain from giving any complaint direct or through any other manner without supporting it with full and certifiable facts.

4.6 The Bidder shall not instigate or cause to instigate any third person to commit any of the actions mentioned above.

## **5 Previous Transgression**

**5.1** The Bidder declares that no previous transgression occurred in the last three years immediately, with any other Employer in respect of any corrupt practices envisaged hereunder that could be justify bidder's exclusion from the tender process.

**5.2** If the Bidder makes incorrect statement on this subject, Bidder can disqualified from the tender process or the contract, if already awarded, can be terminated for such reason.

## **6 Sanctions**

**6.1** The provisions regarding Sanctions for violation of the Integrity Pact include forfeiture of Performance Bond in case the Employer decides to forfeit the same without assigning any reason for Imposing sanction for violation of Integrity Pact.

## **7 Sanctions for violation**

Any breach of the aforesaid provisions by the Employer shall face administrative charges and penal actions as per the existing relevant rules and laws. The breach of the Pact by the Bidder or any one employed by him or acting on his behalf (whether with or without the knowledge of the Bidder) or the commission of any offence by the Bidder or any one employed by him or action on his behalf, shall be dealt with as per the provisions of the Bhutan Penal Code 2004, and the Anti-Corruption Act, 2006. The Employer/relevant agency shall also take all or any one of the following actions, whenever required:-

7.1 To immediately call off the pre-contact negotiations without assigning any reason or giving any compensation to the Bidder. However, the proceedings with the other Bidder(s) would continue.

7.2 The Earnest Money/Security Deposit/Performance bond shall stand forfeited.

7.3 To immediately cancel the contract, if already awarded/signed, without giving any compensation to the Bidder.

7.4 To recover all sums already paid by the Employer.

7.5 To encash the advance bank guarantee and performance bond/warranty bond, if furnished by the Bidder, in order to recover the payments, already made by the Employer, along with interest.

7.6 To cancel all or any other Contracts with the Bidder.

7.7 To debar the Bidder from entering into any bid from the government of Bhutan as per the Debarment clause of the Procurement Manual.

## **8 Conflict of Interest**

8.1 A conflict of interest involves a conflict between the public duty and private interests (for favor or vengeance) of a public official, in which the public official has private interest which could improperly influence the performance of their official duties and responsibilities. Conflict of Interest would arise in a situation when any concerned members of both the parties are related either directly or indirectly, or has any association or had any confrontation. Thus, conflict of interest of any official or the Employer must be declared in the prescribed form attached.

8.2 The Bidder shall not lent to or borrow any money from or enter into any monetary dealings or transactions, directly or indirectly, with any employee of the Employer, and if he does so, the Employer shall be entitled forthwith to rescind the Contract and all other contracts with the Bidder.

## **9 Examination of Books of Accounts**

**9.1** In case of any allegation of violation of any provisions of this Integrity Pact or payment of commission, the Employer or its agencies shall be entitled to examine the Books of Accounts of the Bidder and the Bidder shall provide necessary information of the relevant financial documents and shall extend all possible help for the purpose of such examination.

## **10 Monitoring and Arbitration**

**10.1**The Procurement Division of the Ministry of Finance be responsible for monitoring and arbitration of IP.

## **11 Legal Actions**

11.1The actions stipulated in this Integrity Pact are without prejudice to any other legal action that may follow in accordance with the provisions of the extant law in force relating to any civil or criminal proceedings.

## **12 Validity**

12.1 The validity of this Integrity Pact shall be from the date of its signing and extend up to .....years or the complete execution of the contract to the satisfaction of both the Employer and the Bidder, whichever is later.

12.2 Should one or several provisions of this Pact turn out to be invalid; the remainder of this Pact shall remain valid. In this case, the parties will strive to come to an agreement to their original intentions.

The parties hereby sign this Integrity Pact at \_\_\_\_\_ on \_\_\_\_\_

**EMPLOYER**

**BIDDER**

**Witness:**

**Witness**

- 1.
- 2.

- 1.
- 2.

(Legal Officer/LA)

**Schedule of Guaranteed Technical Particulars****ERW Steel Penstock**

Sl. #	Description	Unit	Bidder's Value
1	Applicable standards		
3.	Materials		
4.	Tensile Strength		
5.	Yield strength		
6.	IS-Standards		
7.	Chemical contents:		
	i) C%		
	ii) Mn %		
	iii) P %		
	iv) S %		
	v) Si %		
	vi) Carbon Equivalent		
8.	Flange details:		
	iv) External Diameter		
	v) Thickness		
	vi) No. of Nuts & Bolts		
9.	Coupling Details:		
	iii) Thickness		
	iv) No. of Nuts & Bolts		
10.	Pipe Dimensions for single length:-		
	vi) Length		
	vii) Outer Diameter		
	viii) Internal Diameter		
	ix) Circumference		
	x) Sheet Thickness		
11.	Approximate weight of the pipe on the assumption that steel weight 7.859/cm <sup>3</sup>		
12.	Tolerance:		
	iv) On length		
	v) On thickness		
	vi) On weight		

**20. DEVIATION FROM and EXCEPTION TO BID DOCUMENT**

The Bidder shall specify below, in detail, all deviations from and exceptions to the bid document. Any entry shall be referenced to the Bid document Clause No. To which they refer.

The Bidder deemed to be compliant with the content and intent of the Bid document except in respect of deviations and exceptions listed in this schedule.

No deviation from and exception to the Bid Document shall be made subsequently to the Contract without the written approval of the Employer.

Clause No.	Details of Deviation /Exception	Reasons for Deviation/Exception

Declaration: This page and attached.....Pages of deviations from the Bid Document is a complete record of such deviations.

In case NO DEVIATION is mentioned here and deviation of clauses/specification is mentioned elsewhere, then it will be taken as a deviation.

Signature of Bidder.....

Place and Date.....

**PRICE SCHEDULE**

**TENDER No: BPC/PSD-TU/Steel Pipes/2011/**

**DATED: October 5, 2011**

**LOT 1 (STEEL PIPES)**

<b>SI#</b>	<b>DESCRIPTION</b>	<b>Unit</b>	<b>Qty</b>	<b>Country of Origin (Make)</b>	<b>Unit Price CIF/CIP Port of Entry</b>	<b>Total Price CIF/ CIP Port of Entry</b>
1	ERW Pipe, Outer dia meter 222.8170 mm, Internal dia. 210.2170 mm, Thickness 6.3 mm, Circumference 700 mm. Minimum pressure 84 kg /sq.mm. Flange: external dia. 343.780 mm, thickness 8 mm, nuts & bolts=8 Nos. to suit the coupling requirement (As per attached drawings and specifications)	Mtr.	120			
2	Coupling details: Thickness 6 mm, Nuts & bolts = 5 Nos. (As per attached drawings and specifications)	Sets.	22			
<b>TOTAL LOT AMOUNT</b>						

Note: In case of discrepancy between the UNIT PRICE and the TOTAL PRICE PER UNIT, the UNIT PRICE shall prevail.

CIF: BPC Regional Stores Division, Phuentsholing Bhutan.

Tender delivery period: 90 Days

Offered delivery period:

Currency for the Payment: Only in Rs or Nu.

Taxes: The rates shall be inclusive of all the taxes and duties both inside and outside the purchaser's country.