

BHUTAN POWER CORPORATION LIMITED

(An ISO 9001:2015, ISO 14001:2015 & OHSAS 18001:2007 Certified Company)
(Registered Office, Thimphu)

PROCUREMENT SERVICES DEPARTMENT **THIMPHU: BHUTAN**



(Tender No: BPC/PSD/ABC & Line Materials/2021/01 dated February 11, 2021)

BID DOCUMENT **FOR** **The Supply and Delivery of HV ABC, LV ABC, Telescopic Pole** **Fittings and Insulators with Fittings Assembly.**

CONTENTS OF THE BID DOCUMENT

SL#	Section	Title	Page
1	-	Checklist for bid submission	
2	Part 1	Bidding Procedures	
3	Section I	Instruction to Bidders (ITB)	4-22
4	Section II	Bid Data Sheet	1-5
5	Section III	Evaluation and Qualification Criteria	1-3
6	Section IV	Bidding Forms	1-12
7	Part 2	Supply Requirements	
8	Section V	Schedule of Supply	1-26
9	Part 3	Conditions of The Contract and Contract Forms	
10	Section VI	General Conditions of Contract (GCC)	3-12
11	Section VII	Special Conditions of Contract (SCC)	1-6
12	Section VIII	Contract Forms	7-11

Note: Part 1 Section IV (Bidding Forms) are enclosed at the end of the bidding document for convenience.



CHECKLIST FOR BID SUBMISSION

Sl #	PARTICULARS	Purchasers Requirement	Bidders to fill up
		YES/NO	YES/NO
1	Signed Bid Form and Price Schedule (BOQ)	YES	
2	Power of Attorney	YES	
3	Valid Trade License/ Manufacturing License	YES	
4	Manufacturer's authorizations	YES	
5	Document Establishing Eligibility of the Bidder	YES	
6	Documents establishing of the Bidders qualification to perform the contract	YES	
7	Documents establishing the goods' conformity to the bidding documents	YES	
8	Guaranteed Technical Particulars (GTP)	YES	
9	EMD drawn in favour of Director, Finance & Account Services, BPC, Thimphu, Bhutan.	YES	
10	Signed Integrity Pact	YES	
11	Signed Vendor Performance Management System (VPMS)	YES	
12	Joint Venture, Consortium or Association (JV/C/A) Partner Information Form (If applicable)	YES	

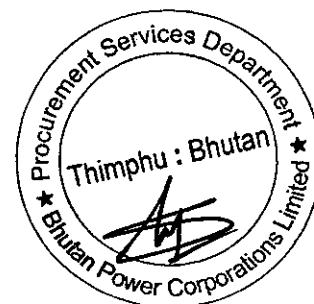



འབྲུག་གློག་མིལ་སྐུ་འཛིན།

Bhutan Power Corporation Limited
(An ISO 9001:2015, ISO 14001:2015 & OHSAS 18001:2007 Certified Company)
Registered Office, Thimphu
Procurement Services Department
Thimphu: Bhutan



Invitation for Bids

Date: February 11, 2021

Tender No.: BPC/PSD/ABC & Line Materials/2021/01

1. The *Procurement Services Department* invites sealed bids from eligible bidders for the supply and delivery of HV ABC, LV ABC, Telescopic Pole Fittings and Insulators.
2. Interested eligible bidders may obtain further information on the bid form and inspect the bidding documents at the office of *General Manager, Procurement Services Department, Bhutan Power Corporation Ltd., Thimphu, Bhutan.*
3. A complete set of bidding documents may be purchased by any interested eligible bidder on submission of written application to the above address on or before **10:30 hours on 11th March 2021** and upon payment of non-refundable fee of **Nu. 2,000.00.**
4. Bidding documents can be also downloaded from the Purchaser's website but should register with the Purchaser on or before **10:30 hours on 11th March 2021** after paying registration fee of **Nu. 200.00** (Ngultrum two hundred) only. The registration shall be done through written application together with the valid business license copy and tax clearance certificate to make the bid enforceable.
5. All bids must be accompanied by a bid security and must be delivered in accordance with the Instructions to Bidder on or before **10:30 hours on 11th March 2021** and will be publicly open immediately thereafter.

Sl.#	Lot Description	Amount (Nu.)
1	HV ABC	375,000.00
2	LV ABC	1,520,000.00
3	Telescopic Pole Fittings	119,000.00
4	Insulators with fitting assembly	87,000.00

6. *Procurement Services Department, Bhutan Power Corporation Ltd.* shall not be responsible for any costs or expenses incurred by bidders in connection with the preparation or delivery of bids.

(General Manager)

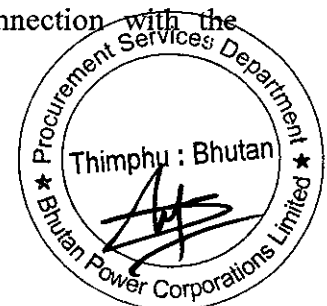

PART 1- Bidding Procedures

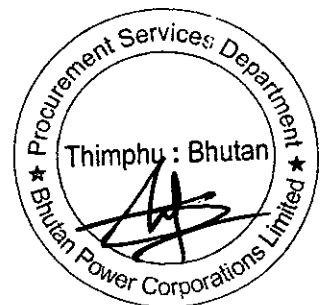

Section I. Instructions to Bidders

Table of Contents

A. General

1. Scope of Bid..... 4

2. Fraud and Corruption..... 4

3. Eligible Bidders 5

4. Exclusion of Bidders..... 6

5. Vendor Performance Management System (VPMS)..... 6

6. Joint Ventures 6

B. Contents of Bidding Documents

7. Sections of Bidding Documents..... 7

8. Clarification of Bidding Documents..... 7

9. Amendment of Bidding Documents 8

C. Preparation of Bids

10. Cost of Bidding Documents..... 8

11. Language of Bid..... 8

12. Documents Comprising the Bid..... 8

13. Bid form..... 9

14. Price Schedules 9

15. Alternative Bids 9

16. Bid Prices and Discounts 9

17. Bid Currencies 11

18. Documents Establishing Eligibility of the Bidder 11

19. Documents Establishing Qualifications of the Bidder..... 11

20. Documents Establishing the Goods' Conformity to the Bidding Documents..... 11

21. Period of Validity of Bids..... 12

22. Bid Security... 12

23. Formats and Signing of Bid 13

D. Submission and Opening of Bids

24. Submission, Sealing and Marking of Bids..... 14

25. Deadline for submission of Bids..... 14

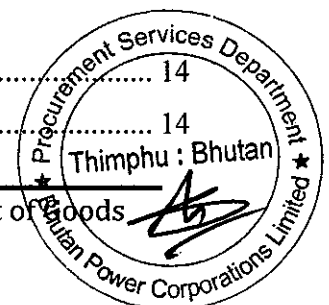

Section I-Instructions to Bidders

26.	One Bid per Bidder	14
27.	Late Bids	14
28.	Modification, Substitution and withdrawal of Bids	15
29.	Bid Opening	15
E.	Evaluation and Comparison of Bids	
30.	Confidentiality	16
31.	Clarification of Bids.....	17
32.	Deviations, Reservations, and Omissions	17
33.	Responsiveness of Bids.....	17
34.	Nonconformities, Errors and Omissions.....	18
35.	Preliminary Examination of Bids.....	18
36.	Examination of Terms and Conditions; Technical Evaluation	18
37.	Conversion to to Single Currency.....	19
38.	Margin of Preference	19
39.	Evaluation of Bids.....	19
40.	Comparison of Bids	20
41.	Post qualification of the Bidder	20
42.	Contacting the Purchaser	21
43.	Purchaser's Right to Accept Any Bid and to Reject Any or All Bids.....	21
F.	Award of Contract21
44.	Award Criteria	21
45.	Purchasers Right to Vary Quantities at Time of Award	21
46.	Notification of Award	21
47.	Signing of Contract.....	21
48.	Performance Security.....	22

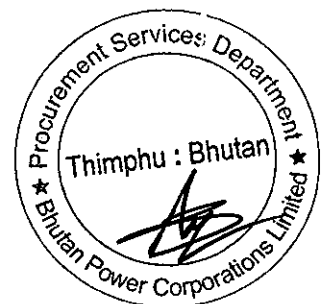

Section I. Instructions to Bidders

A. General

1. Scope of Bid	
1.1	The Purchaser, as indicated in the Bid Data Sheet (BDS), issues these Bidding Documents for the supply of Goods and Services incidental thereto as specified in Section V, Schedule of Supply. Tender number and tender description, lot numbers and lot description are provided in the BDS.
1.2	All bids are to be completed and returned to the Purchaser in accordance with these instructions to the bidders.
1.3	Throughout this Bidding Document :
	a. the term "in writing" means communicated in written form with proof of receipt;
	b. if the context so requires, singular means plural and vice versa; and
	c. "day" means calendar day
2. Fraud and Corruption	
2.1	It is Corporation policy to require that Purchasers, Bidders and Suppliers observe the highest standards of ethics during the procurement and execution of contracts. ¹ In pursuance of this policy, the Corporation:
a.	defines, for the purposes of this provision, the terms set forth below as follows:
i.	"Corrupt practice" ² is the offering, giving, receiving or soliciting, directly or indirectly, of anything of value ³ to influence improperly the actions of another party;
ii.	"Fraudulent practice" ⁴ is any intentional act or omission, including a misrepresentation, that knowingly or recklessly misleads, or attempts to mislead, a party to obtain a financial or other benefit or to avoid an obligation;
iii.	"Collusive practice" ⁵ is an arrangement between two or more parties designed to achieve an improper purpose, including to influence improperly the actions of another party;
iv.	"Coercive practice" ⁶ is impairing or harming, or threatening to impair or harm, directly or indirectly, any party or the property of the party to influence improperly the actions of a party;

¹ In this context, any action taken by a Bidder, and Supplier to influence the procurement process or contract execution for undue advantage is improper.

² "another party" refers to a Corporation official acting in relation to the procurement process or contract execution. In this context, "Corporation official" includes employees of BPC taking or reviewing procurement decisions.

³ "anything of value" includes, but is not limited to, any gift, loan, fee, commission, valuable security or other asset or interest in an asset; any office, employment or contract; any payment, discharge or liquidation of any loan, obligation or other liability whatsoever, whether in whole or in part; any other services, favour or advantage, including protection from any penalty or disability incurred or apprehended or from any action or proceeding of a disciplinary or penal nature, whether or not already instituted and including the exercise or the forbearance from the exercise of any right or any official power or duty.

⁴ a "party" refers to a Corporation official; the terms "benefit" and "obligation" relate to the procurement process or contract execution; and the "act or omission" is intended to influence the procurement process or contract execution.

⁵ "parties" refers to participants in the procurement process (including corporation officials) and an "improper purpose" includes attempting to establish bid prices at artificial, non competitive levels.

⁶ a "party" refers to a participant in the procurement process or contract execution.

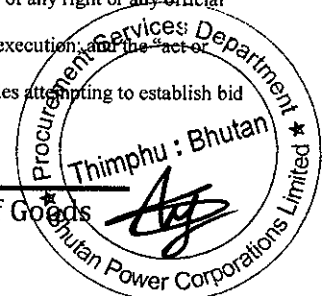

Section I-Instructions to Bidders

	v.	"Obstructive practice" is
	aa.	deliberately destroying, falsifying, altering or concealing of evidence material to the investigation or making false statements to investigators in order to impede any investigation into allegations of a corrupt, fraudulent, coercive or collusive practice; and/or threatening, harassing or intimidating any party to prevent it from disclosing its knowledge of matters relevant to the investigation or from pursuing the investigation; or
	bb.	acts intended materially to impede the exercise of the inspection and audit rights of the Purchaser or any person appointed by the Purchaser and/or any relevant agency provided for under ITB Sub-Clause 2.1 (d) below.
b.		will reject a proposal for award if it determines that the Bidder recommended for award has, directly or through an agent, engaged in corrupt, fraudulent, collusive, coercive or obstructive practices in competing for the contract in question;
c.		will sanction a firm or individual, including declaring them ineligible, either indefinitely or for a stated period of time, to be awarded contract if it at any time determines that they have, directly or through an agent, engaged in corrupt, fraudulent, collusive, coercive or obstructive practices in competing for, or in executing contract;
d.		will have the right requiring Bidders and Suppliers to permit the Purchaser, any agency or person appointed by the Purchaser to inspect their accounts and records and other documents relating to their Bid submission and contract performance and to have them audited by auditors appointed by the Purchaser;
e.		requires that Bidders, as a condition of admission to eligibility, execute and attach to their bids an Integrity Pact Statement in the form provided in Section IV, Bidding Forms. Failure to provide a duly executed Integrity Pact Statement shall result in disqualification of the Bid; and
f.		will report any case of corrupt, fraudulent, collusive, coercive or obstructive practice to the relevant RGoB agencies, including but not limited to the Anti-corruption Commission (ACC) of Bhutan, for necessary action in accordance with the statutes and provisions of the relevant agency.

3. Eligible Bidders

3.1	The Invitation for bids is open to all Manufacturers/Export House/Authorized Dealers from outside Bhutan and to Manufacturers/Authorized Dealers/National Suppliers licensed under the Ministry of Economic Affairs of Royal Government of Bhutan (Supporting evidence to corroborate the claim must be enclosed).
3.2	A Bidder shall not be eligible who have a conflict of interest. All Bidders found to have a conflict of interest shall be disqualified. Bidders are considered to have a conflict of interest in this bidding process if they:
a.	are associated, or have been associated in the past, with a firm or any of its affiliates which has been engaged by the Purchaser to provide consulting services for the preparation of the design, specifications and/or other documents to be used for the procurement of the Goods to be purchased pursuant to these Bidding Documents, or

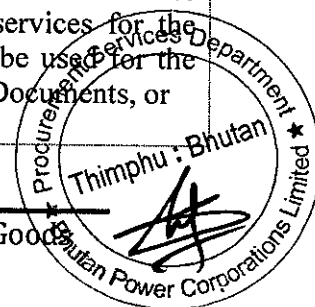

Section I-Instructions to Bidders

	b.	employ or otherwise engage, either directly or through any of their affiliates, a family member of a Corporation who either is employed by the Purchaser or has an authority over it. For the purposes of this Sub-Clause a family member is defined as parents, spouse and children as mentioned in the Service Record of the employee.
--	----	--

4. Exclusion of Bidders

4.1	A bidder shall be excluded from participating in a procurement procedure under the following circumstances who:	
	a.	is suspended/debarred by any Statutory Agencies in Bhutan or in the region to Corporation's knowledge;
	b.	has been declared bankrupt, judgment or pending legal action that could impair operating as a going concern;
	c.	has been found guilty of professional misconduct by a recognised tribunal;
	d.	has not fulfilled his obligations with regard to any statutory dues;
	e.	is or has been guilty of serious misrepresentation in supplying information required under this Section.
	f.	is debarred from participation in any public procurement by any Competent Authority as per law;
	g.	does not qualify under the performance assessed through the Vendor Performance Management System of the Corporation;
	h.	as a matter of law or official regulation, Royal Government of Bhutan prohibits commercial relations with the country in which the Bidder is constituted, incorporated or registered.

5. Vendor Performance Management System (VPMS)

5.1	The performance of the vendor shall be assessed as per the guidelines contained in the Vendor Performance Management System available in BPC website (www.bpc.bt) for the purpose of determining the eligibility in participating in subsequent tenders.	
5.2	The VPMS acceptance form is provided in the Section IV, Bidding Forms of the bidding documents. The bidders are required to sign VPMS Acceptance Form agreeing to the applicability of VPMS. In case the VPMS Acceptance Form is not signed, the bid for that bidder shall be liable for rejection.	

6. Joint Ventures (JV)

6.1	Bids submitted by a Joint Venture of two or more Companies as partners shall comply with the following requirements:	
	a.	the Bid, and in case of successful Bid, the Contract form, shall be signed so as to be legally binding on all partners;
	b.	one of the partners shall be authorized to be in charge; and this authority shall be evidenced by submitting a power of attorney signed by legally authorized signatories of all the partners;
	c.	the partner in charge shall be authorized to incur liabilities, receive payments and receive instructions for and on behalf of any or all partners of the joint venture;

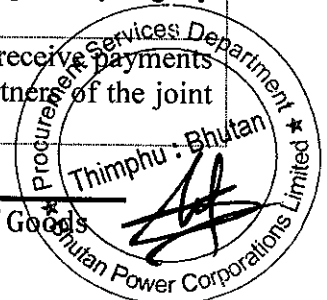

Section I-Instructions to Bidders

d.	all partners of the joint venture shall be liable jointly and severally for the execution of the Contract in accordance with the Contract terms, and a relevant statement to this effect shall be included in the authorization mentioned under (b) above as well as in the Bid Form and the Form of Agreement (in case of a successful Bid); and
e.	a copy of the registration certificate/license of joint venture shall be submitted with the Bid;

B. Contents of Bidding Documents

7. Sections of Bidding Documents

7.1 The Bidding Document consist of Parts 1, 2, and 3, which include all the Sections indicated below, and should be read in conjunction with any Addenda issued in accordance with ITB 9.

PART 1 Bidding Procedures

- Section I. Instructions to Bidders (ITB)
- Section II. Bid Data Sheet (BDS)
- Section III. Evaluation and Qualification Criteria
- Section IV. Bidding Forms

PART 2 Supply Requirements

- Section V. Schedule of Supply

PART 3 Conditions of Contract and Contract Forms

- Section VI. General Conditions of Contract (GCC)
- Section VII. Special Conditions of Contract (SCC)
- Section VIII. Contract Forms

7.2 The Purchaser is not responsible for the completeness of the Bidding Document and its addenda, if they were not obtained directly from the Purchaser.

7.3 The bidder is expected to examine the bidding documents, including all instructions, forms, terms and specifications. Failure to furnish all information required by the bidding documents or submission of a bid not substantially responsive to the Bidding Documents in every respect would result in the rejection of that Bid.

8. Clarification of Bidding Documents

8.1 The bidders shall not be allowed to seek any clarifications on the bidding documents in person or through any verbal communications.

8.2 Prospective bidders requiring any further information or clarification of the bidding documents may notify the Purchaser in writing at the Purchaser's mailing address indicated in the BDS. The Purchaser will respond in writing to any request for information or clarification of the bidding documents, which it receives no later than 14 days before the closing date of the bidding process.

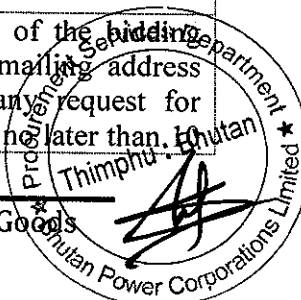

Section I-Instructions to Bidders

	(ten) days prior to the deadline for the submission of Bids prescribed by the Purchaser. The Purchaser's response (including an explanation of the query) will be sent in writing to all prospective bidders who have purchased the Bidding Documents.
8.3.	Pre bid meeting shall be conducted if necessary to clarify doubts and concerns of the bidders prior to submission of bids. Minutes of the pre bid meeting shall be circulated to all bidders that have purchased bidding documents and shall form an integral part of the bidding document.
9. Amendment of Bidding Documents	
9.1	At any time prior to the deadline for submission of bids, the Purchaser may, for any reason, whether at its own initiative or in response to a clarification requested by a prospective bidder, modify the Bidding Documents by addendum.
9.2	The addendum shall be part of the Bidding Documents and shall be notified in writing to all prospective bidders who have purchased the Bidding Documents. Such addendum shall be binding and shall require that prospective Bidders confirm receipt of it before the time established for the opening of Bids.
9.3	In order to afford prospective bidders reasonable time in which to take the addendum into account in preparing their Bids, the Purchaser may, at its discretion, extend the deadline for the submission of Bids.
9.4	Prospective bidders who may have downloaded the bidding documents from the website, the corrigendum to the bidding documents will also be published on the web site. It will be the responsibility of such bidders to regularly visit the website for any addendum to the bidding documents until the last date of bid submission. Purchaser shall in no way be responsible for any ignorance of the bidder about the addendum to the bidding documents.
C. Preparation of Bids	
10. Cost of Bidding Documents	
10.1	The bidder shall bear all costs associated with the preparation and delivery of its bid and the Purchaser will in no case be responsible or liable for those costs, regardless of the conduct or outcome of the bidding process.
10.2	Prospective bidders who may have downloaded the bidding documents from the web site should register with Purchaser on or before the closing of Bid Sale Date and make payment for the cost of the bid documents.
11. Language of Bid	
11.1	The Bid and all correspondence and documents relating to the Bid exchanged by the bidder and the Purchaser shall be written in the language specified in the BDS. Supporting documents and printed literature that are part of the Bid may be in another language provided they are accompanied by an accurate translation of the relevant passages in language specified in BDS, in which case, for purposes of interpretation of the Bid, <i>such</i> translation shall govern.
12. Documents Comprising the Bid	
12.1	The Bid shall comprise the following:
a.	Bid Form and Price Schedules completed in accordance with ITB13, 14, 15 and 17;

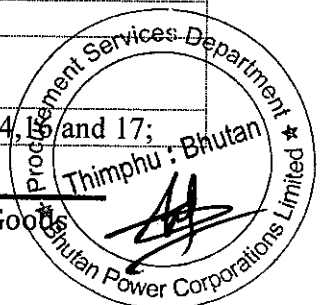

Section I-Instructions to Bidders

b.	Documentary evidence establishing in accordance with ITB 18, that the bidder is eligible to bid.
c.	Documentary evidence establishing in accordance with ITB 19, that the bidder is qualified to perform the Contract if its Bid is accepted;
d.	Documentary evidence establishing in accordance with ITB 20, that the goods to be supplied by the bidder conform to the Bidding Documents;
e.	Bid security furnished in accordance with ITB 22;
f.	Written confirmation authorizing the signatory of the Bid to commit the Bidder, in accordance with ITB 23;
g.	Alternative bids, if permissible, in accordance with ITB 15;
h.	Integrity Pact Statement, in accordance with ITB 2.1(e);
i.	VPMS acceptance form, in accordance with ITB 5; and
j.	Any other document required as per the bidding documents.
13. Bid form	
13.1	The bidder shall complete the Bid Form furnished in Section IV, Bidding Forms. This form must be completed without any alterations to its format, and no substitutes shall be accepted. All blank spaces shall be filled in with the information requested. A bid in which the bid form is not duly filled, signed and sealed by the bidder shall be rejected.
14. Price Schedules	
14.1	The bidder shall complete the appropriate Price Schedule included herein, stating the unit prices, total price per item, the total amount and the expected countries of origin of the Goods to be supplied under the Contract. This Price Schedules form must be completed without any alterations to its format, and no substitutes shall be accepted.
15. Alternative Bids	
15.1	Unless otherwise indicated in the BDS, alternative bids shall not be considered.
16. Bid Prices and Discounts	
16.1	The prices and discounts quoted by the Bidder in the Bid Form and in the Price Schedules shall conform to the requirements specified below.
16.2	All lots and items must be listed and priced separately in the Price Schedules.
16.3	The price to be quoted in the Bid Form shall be the total price of the Bid excluding any discounts offered.
16.4	The Bidder shall quote any unconditional discounts and the methodology for their application in the Bid Form. The discount letter offer shall be accepted only when enclosed inside the main envelope of the bidding document.
16.5	The terms EXW, CIF, CIP, DDP and other similar terms shall be governed by the rules

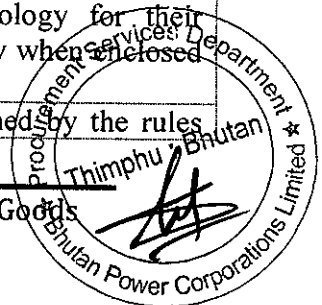

Section I-Instructions to Bidders

	prescribed in the current edition of Inco terms, published by The International Chamber of Commerce, at the date of the Invitation for Bids or as specified in the BDS .	
16.6	Prices shall be quoted as specified in each Price Schedule included in Section IV, Bidding Forms. The disaggregation of price components shall be solely for the purpose of facilitating the comparison of Bids by the Purchaser. This shall not in any way limit the Purchaser's right to contract on any of the terms offered:	
	a.	For Goods manufactured in Bhutan:
	i.	the price of the Goods, quoted ex works, ex-factory, ex-warehouse, ex showroom or off-the-shelf, as applicable, including all Customs duties and sales and other taxes already paid or payable on the components and raw material used to manufacturer or assembly of Goods, if specified in BDS;
	ii.	any Bhutan sales and other similar taxes which will be payable on the Goods if the contract is awarded to the Bidder, if specified in BDS; and
	iii.	the total price for the item.
	b.	For Goods to be offered from outside Bhutan:
	i.	the price of the Goods, quoted CIP/DDP place of entry in Bhutan, as specified in BDS;
	ii.	custom duties and any other taxes which will be payable on the Goods in Bhutan, if specified in BDS;
	iii.	the cost of inland transportation, insurance and other local costs incidental to delivery of the Goods from the port of entry to their final destination, if specified in BDS; and
	iv.	the total price for the item.
	c.	For Related Services, other than inland transportation and other services required to convey the Goods to their final destination, whenever such Related Services are specified in Section V, Schedule of Supply:
	i.	the price of each item comprising the Related Services (inclusive of any applicable taxes).
16.7	Prices quoted by the Bidder shall be fixed during the Bidder's performance of the Contract and not subject to variation on any account, unless otherwise specified in the BDS. A bid submitted with an adjustable price quotation shall be treated as non-responsive and shall be rejected pursuant to ITB 33 unless adjustable price quotations are permitted by the BDS. If, in accordance to BDS, prices quoted by the Bidder shall be subject to adjustments during the performance of the Contract, a Bid submitted with a fixed price quotation shall not be rejected, but price adjustment shall be treated as zero.	
16.8	<p>If so indicated pursuant to ITB 1.1, Bids are based on Lots/Packages, for which all goods are grouped in lots for easy identification.</p> <p>For the purpose of bidding and inventory management, related SKUS shall be grouped under specific lots like transformers, conductors, cables and fabrication items or in the manner most advantageous to the BPC for a particular tender.</p> <p>Bidders shall have the option of submitting a proposal on any or all LOTS. Each lot consists of items grouped in packages. Unless otherwise indicated in the BDS, prices quoted shall correspond to one hundred percent (100%) of the items specified for each lot and to one hundred percent (100%) of the quantities for each item of a lot. Bidders can offer any price reduction (discount) for any or all Lots and shall specify in their Bid the price reductions</p>	

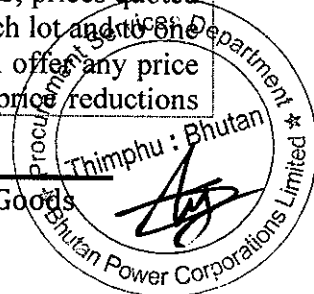

Section I-Instructions to Bidders

	applicable to each Lot, or for all the Lots. Price reductions or discounts shall be submitted in accordance with ITB 16.4.
17.	Bid Currencies
17.1	<p>Bid Prices shall be quoted in Ngultrum for goods offered from Bhutan, in Indian Rupees for goods offered from India; and in US dollar/major foreign currencies for goods offered from other Countries.</p> <p>Bid Prices expressed in Indian currency and US Dollars/major foreign currencies shall be accepted and evaluated in accordance to ITB 37. For bid evaluation purpose the exchange rate will be based on the Telegraphic Transfer (TT) selling rate published by the Royal Monetary Authority of Bhutan on the day of bid opening. For bid expressed in Indian currency and US Dollars/major foreign currencies, payments shall be made in equivalent Ngultrum through banking channel and the responsibilities of payment transfer and transfer charges lie on the Suppliers.</p>
18.	Documents Establishing Eligibility of the Bidder
18.1	The bidder shall furnish, as part of its Bid, certification establishing the bidder's eligibility to bid pursuant to ITB 3.
18.2	The necessary documents and literatures viz. ISO Certificate, Type Test Certificates and Lists of Past Performance Certificates from the users must be submitted for new makes/brands introduced in Bhutan.
18.3	If the Bidder is JV in accordance with ITB 6, a copy of the registration certificate/license shall be submitted.
19.	Documents Establishing Qualifications of the Bidder.
19.1	The documentary evidence of the Bidder's Qualification to Perform the Contract, if its bid is accepted, shall establish to the purchaser's satisfaction:
	<p>a. That, if required by the BDS, a Bidder is not a manufacturer or otherwise produce the goods it offers to supply, shall submit the Manufacturer's Authorization using the form included in Section IV, Bidding Forms to demonstrate that it has been duly authorized by the manufacturer or producer of the Goods to supply these Goods in Bhutan;</p> <p>b. That, if required by the BDS, in the case of a bidder not doing business in Bhutan, the Bidder is, or will be (if the contract is awarded to it), represented by authorised representative in Bhutan equipped and able to carry out the Supplier's maintenance, repair and spare parts-stocking obligations prescribed in the Conditions of Contracts and/or Technical Specifications.</p> <p>c. That the Bidder meets each of the qualification criteria specified in Section III, Evaluation and Qualification Criteria.</p>
20.	Documents Establishing the Goods' Conformity to the Bidding Documents.
20.1	To establish the conformity of the Goods to the Bidding Documents, the Bidder shall furnish as a part of its Bid, the documentary evidence that the Goods conform to the technical specifications and standards specified in Section V, Schedule of Supply.

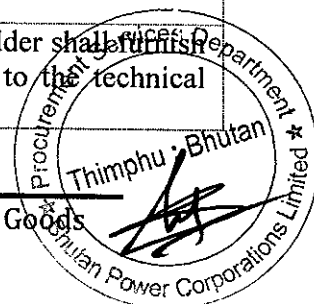

Section I-Instructions to Bidders

20.2	The documentary evidence may be in the form of literature, drawings or data, and shall consist of a detailed item by item description of the essential technical and performance characteristics of Goods. If required by the BDS, the bidders are required to confirm and sign on the guaranteed technical particulars of the goods (GTPS) that is indicated in the Section V, Schedule of Supply. Any deviations from the indicated specifications must be clearly indicated in the deviation schedule, Section IV, Bidding Form.
20.3	If required, the Bidder shall also furnish a list giving full particulars, including available sources and current prices, of all spare parts, special tools, etc., necessary for the proper and continuing functioning of the Goods.
20.4	Standards for workmanship, material and equipment, and references to brand names or catalogue numbers, specified by the Purchaser in Section V, Schedule of Supply, are intended to be descriptive only and not restrictive. The bidder may offer other standards of quality, brand names and/or catalogue numbers in its Bid, provided that it demonstrates to the Purchaser's satisfaction that the substitutions are equivalent or superior to those designated in Section V, Schedule of Supply with the exception in strategic critical and strategic security items category.
20.5	In order to prove that the Goods offered are of acceptable quality and standard, the bidders shall furnish the documentary evidence that the Goods offered have been in production and all relevant catalogues, test certificates, ISO certificates, list of previous clients, value of business and company or manufacturer profile for all new brands are submitted.
21.	Period of Validity of Bids
21.1	Bids shall remain valid for the period specified in the BDS days from the date of bid opening prescribed by the Purchaser, pursuant to ITB 28. A bid valid for a shorter period shall be rejected by the Purchaser as non-responsive.
21.2	In exceptional circumstances, prior to the expiration of the bid validity period, the Purchaser may solicit bidder's consent to an extension of the period of bid validity. The request and the responses thereto shall be made in writing. If the bidder agrees to the extension request, the validity of the bid security provided under ITB 22 shall also be suitably extended. In the event the Bidder refuses the request, the bid shall be disqualified without forfeiting the bid security. Bidders granting the request shall not be required or permitted to modify its Bid.
22.	Bid Security
22.1	The bidder shall furnish, as part of its Bid, a Bid Security in original form, denominated in Ngultrum or a freely convertible currency and in amount specified in the BDS.
22.2	The Bid Security shall be in one of the following forms acceptable to the purchasers:
a.	Unconditional bank guarantee issued by a reputed Financial Institution acceptable to the Purchaser in the Bid Security Form included in Section IV Bidding Form or another form acceptable to the Purchaser.
b.	Banker's cheque/ cash warrant.

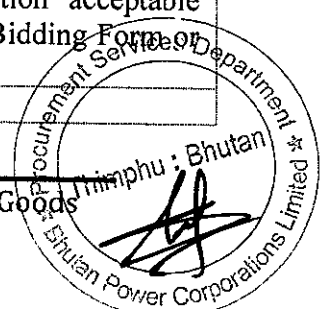

Section I-Instructions to Bidders

	c.	Demand draft.
	d.	If the institution issuing the Bid Security furnished by the Bidder is located outside the Purchaser's country, the Bid Security shall be counter guaranteed by a correspondent financial institution located in the Purchaser's country to make it enforceable,
22.3		The Bid Security shall be valid for period of thirty (30) days beyond the validity period of the Bids as specified in BDS.
22.4		Any Bid not secured in accordance with ITB 22.1, 22.2 and 22.3 above shall be rejected by the Purchaser as non-responsive.
22.5		An unsuccessful bidder's bid security will be discharged/returned within fifteen (15) days after signing of the Contract with the successful Bidder.
22.6		The successful bidder's bid security will be discharged/returned upon furnishing the performance security, pursuant to ITB 46 and the bidder's executing the Contract, pursuant to ITB 47 .
22.7		The bid security may be forfeited:
	a.	If a bidder withdraws its Bid during the period of bid validity specified by the bidder on the Bid Form, except as provided in ITB 21.2;
	b.	If a bidder does not accept arithmetical corrections of its bid price;
	c.	In the case of a successful bidder, if the bidder fails
	i.	To sign the Contract in accordance with ITB 47; or
	ii.	To furnish the performance security in accordance with ITB 48.
22.8		The Bid Security of a JV must be from the JV that submits the Bid.
23.		Formats and Signing of Bid
23.1		The Bidder shall prepare one original of the documents comprising the Bid as described in ITB 12 and clearly mark it as "Original ". In addition, the Bidder shall submit copies of the Bid, in the number specified in the BDS and clearly mark them "COPY". In the event of any discrepancy between the original and the copies, the original shall prevail.
23.2		The original and all copies of the Bid shall be typed or written in indelible ink and shall be signed by the bidder or a person(s) duly authorized to sign on behalf of the bidder. Written power-of-attorney shall indicate such authorization and shall be attached to the Bid. The name and position held by each person signing must be typed or printed below the signature.
23.3		The Bid shall contain no interlineations, erasures or overwriting except as necessary to correct errors made by the bidder, in which case such correction shall be initialled by the person or persons signing the Bid.

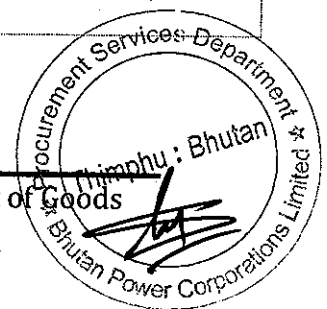

D. Submission and Opening of Bids											
24. Submission, Sealing and Marking of Bids											
24.1	Bids shall be delivered by hand, courier or registered post. The Bidder shall seal the original of the Bid and the number of copies stipulated in the BDS, including alternative Bids if permitted in accordance with ITB 15 in separate inner envelopes contained within one outer envelope. All envelopes shall be sealed with adhesive or other sealant to prevent reopening.										
24.2	The inner envelopes shall: <table border="0" style="margin-left: 20px;"> <tr> <td style="padding-right: 10px;">a.</td> <td>Be sealed and bear the name of the Bidder.</td> </tr> <tr> <td>b.</td> <td>Be marked "ORIGINAL", "ALTERNATIVE" (if any) and "COPY".</td> </tr> </table>	a.	Be sealed and bear the name of the Bidder.	b.	Be marked "ORIGINAL", "ALTERNATIVE" (if any) and "COPY".						
a.	Be sealed and bear the name of the Bidder.										
b.	Be marked "ORIGINAL", "ALTERNATIVE" (if any) and "COPY".										
24.3	The outer envelope shall: <table border="0" style="margin-left: 20px;"> <tr> <td style="padding-right: 10px;">a.</td> <td>Be marked "Confidential";</td> </tr> <tr> <td>b.</td> <td>Bear the name and address of the Bidder;</td> </tr> <tr> <td>c.</td> <td>Be addressed to the Purchaser in accordance with ITB 25.1;</td> </tr> <tr> <td>d.</td> <td>Bear the identification number pursuant to ITB 1.1 and any additional identification marks as specified in the BDS; and</td> </tr> <tr> <td>e.</td> <td>Bear a warning not to open before the time and date for bid opening, in accordance with ITB 29.1.</td> </tr> </table>	a.	Be marked "Confidential";	b.	Bear the name and address of the Bidder;	c.	Be addressed to the Purchaser in accordance with ITB 25.1;	d.	Bear the identification number pursuant to ITB 1.1 and any additional identification marks as specified in the BDS; and	e.	Bear a warning not to open before the time and date for bid opening, in accordance with ITB 29.1.
a.	Be marked "Confidential";										
b.	Bear the name and address of the Bidder;										
c.	Be addressed to the Purchaser in accordance with ITB 25.1;										
d.	Bear the identification number pursuant to ITB 1.1 and any additional identification marks as specified in the BDS; and										
e.	Bear a warning not to open before the time and date for bid opening, in accordance with ITB 29.1.										
24.4	If the outer envelope is not sealed and marked as required by ITB 24.3, the Purchaser will assume no responsibility for the bid misplacement or premature opening.										
25. Deadline for submission of Bids											
25.1	Bids shall be delivered by hand, courier or registered post to the Purchaser at the address and no later than the date and time indicated in BDS.										
25.2	The Purchaser may, at its discretion, extend the deadline for the submission of Bids by amending the Bidding Documents in accordance with ITB 9, in which case all right and obligations of the Purchaser and bidders previously subject to the deadline will thereafter be subject to the deadline as extended.										
26. One Bid per Bidder											
26.1	Each bidder shall submit only one Bid either by itself, or as a partner in a joint venture or as a responsible officer in the management of the company. A bidder who submits or participates in more than one Bid (except alternative Bids if allowed, pursuant to ITB 15) shall be disqualified.										
27. Late Bids											
27.1	Any Bid received by the Purchaser after the deadline for Submission of Bids prescribed by the Purchaser, pursuant to ITB 25, shall be declared "Late" and rejected and returned unopened to the bidder.										

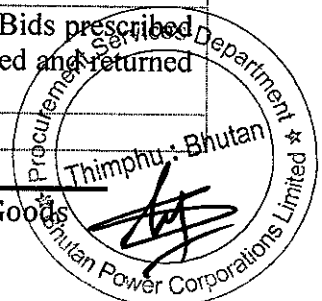

Section I-Instructions to Bidders

28. Modification, Substitution and withdrawal of Bids	
28.1	The bidder may modify or substitute its Bid after it has been submitted by sending a written notice in accordance with the ITB 24, duly signed by an authorized representative, and shall include a copy of authorization in accordance with ITB 23.2. The corresponding substitution or modification of the Bid must accompany the respective written notice. All notices must be:
	a. Submitted in accordance with ITB 23 and 24, and in addition, the respective envelopes shall be clearly marked "SUBSTITUTION" or "MODIFICATION;" and
	b. Received by the Purchaser prior to the deadline prescribed for the submission of Bids, in accordance with ITB 25.
28.2	The bidder may withdraw its Bid after it has been submitted by sending a written notice prior to the deadline prescribed for the submission of Bids, in accordance with ITB 25, duly signed by an authorized representative, and shall include a copy of authorization in accordance with ITB 23.2. The Purchaser then shall mark the envelope as "WITHDRAWN".
28.3	No Bid may be modified, substituted or withdrawn in the interval between the deadline for submission of Bids and the expiration of the period of bid validity specified by the bidder on the Bid Form or any extension thereof, neither any modification shall be accepted.
29. Bid Opening	
29.1	The Purchaser shall conduct the bid opening in the place at the address, date and time specified in the BDS in the presence of bidders or bidders' authorized representatives who choose to attend.
29.2	The bidder's authorized representatives attending the bid opening shall have an Authorization Letter from the bidder. Only the authorized representative shall attend the bid opening.
29.3	The bidders or bidder's authorized representatives shall not be permitted to approach the members of the Bid Opening Committee or any of the officials.
29.4	The bidders or bidder's authorized representatives who are present shall sign a bidder's attendance sheet evidencing their attendance.
29.5	First, envelopes marked as "WITHDRAWN" shall be read out and returned unopened to the Bidder. Next, envelopes marked "SUBSTITUTION" shall be opened and read out and exchanged with the corresponding Bid being substituted. The substituted Bid shall not be opened, but shall be returned to the Bidder. Envelopes marked "MODIFICATION" shall be opened and read out with the corresponding Bid. Only envelopes that are opened, read out and recorded at Bid Opening shall be considered.
29.6	All other envelopes shall be opened one at a time, and the following read out and recorded: the

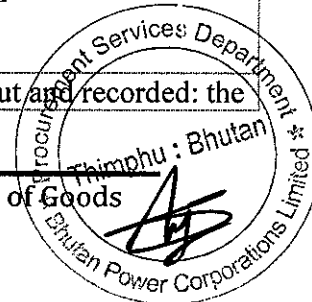

Section I-Instructions to Bidders

	name of the Bidder and whether there is a modification; the Bid Prices (per lot if applicable), any discounts and alternative offers; the presence of a Bid Security, if required; and any other details as the Purchaser may consider appropriate. Only discounts and alternative offers read out and recorded at bid opening shall be considered for evaluation. No Bid shall be rejected at bid opening except for late bids, in accordance with ITB 27.1.
29.7	The Purchaser shall prepare a record of the Bid Opening, which shall include the information disclosed to those present in accordance with ITB 29.6. The minutes shall include, as a minimum:
a.	The Tender Number and Description;
b.	The name of the Bidder, Bid number and whether there is a withdrawal, substitution or modification;
c.	The Bid deadline date and time;
d.	The date, time and place of Bid Opening;
e.	Bid prices, per lot if applicable, offered by the Bidders, including any discounts and alternative offers;
f.	The presence or absence of Bid Security and, if present, its amount;
g.	The names of Bidders at the Bid Opening, and of the Bidders authorized representatives (if any);
h.	Details of any feedbacks or other comments made by Bidders/Bidders authorized representatives attending the Bid Opening, including the names and signatures of the Bidders/Bidders authorized representatives making the feedback(s) and/or comment(s); and
i.	The names, designations and signatures of the members of the Bid Opening Committee.
	The Bidders/Bidders authorized representatives who are present shall sign the record. The omission of a Bidders/Bidders authorized representative's signature on the record shall not invalidate the contents and effect of the record.
E. Evaluation and Comparison of Bids	
30. Confidentiality	
30.1	Information relating to the examination, clarification, evaluation and comparison of Bids and recommendations for the award of a contract shall not be disclosed to Bidders or any other persons not officially concerned with such process.

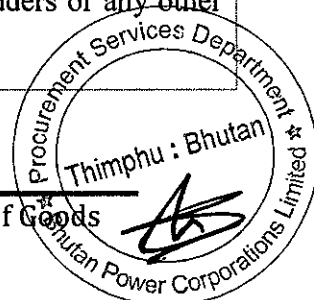

30.2	Any effort by a Bidder to influence the Purchaser's processing of Bids or award decisions may result in the rejection of the bidder's Bid.	
31.	Clarification of Bids	
31.1	To assist in the examination, evaluation and comparison of Bids, the Purchaser may, at its discretion, ask the bidder for a clarification of its Bid. Any clarification submitted by a Bidder with regard to its Bid and that is not in response to a request by the Purchaser shall not be considered. The Purchaser's requests for clarification and the response shall be in writing. No change in the price or substances of the Bid shall be sought, offered or permitted, except to confirm the correction of arithmetic errors discovered by the Purchaser in the evaluation of the Bids, in accordance with ITB 34.	
32.	Deviations, Reservations, and Omissions	
32.1	During the evaluation of bids, the following definitions shall apply:	
	a.	"Deviation" is a departure from the requirements specified in the Bidding Document. Any comments, remarks, observations and feedbacks will constitute as deviation and shall be indicated in the deviation sheet;
	b.	"Reservation" is the setting of limiting conditions or withholding from complete acceptance of the requirements specified in the Bidding Document; and
	c.	"Omission" is the failure to submit part or all of the information or documentation required in the Bidding Document.
33.	Responsiveness of Bids	
33.1	The Purchaser's determination of a Bid's responsiveness shall be based on the contents of the Bid itself, and is to determine which of the Bids received are responsive and thereafter to compare the responsive Bids against each other to select the lowest evaluated Bid.	
33.2	A substantially responsive Bid is one that conforms to all the terms, conditions and specifications of the Bidding Documents without material deviation, reservation or omission. A material deviation, reservation or omission is one that:	
	a.	Effects in any substantial way the scope, quality or performance of the supplies; or
	b.	Limits or is inconsistent with the bidding documents in a substantial way, the Purchaser's rights or the bidder's obligations under the Contract; or
	c.	Whose rectification would affect unfairly the competitive position of other Bidders presenting substantially responsive Bids.
33.3	If a Bid is not substantially responsive to the Bidding Documents, it shall be rejected by the Purchaser and may not subsequently be made responsive by the bidder by correction of the material deviation, reservation or omission.	

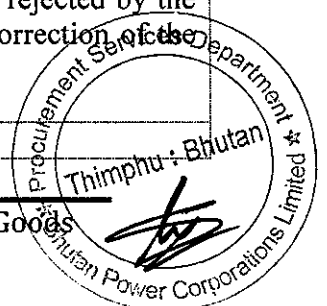

34. Nonconformities, Errors and Omissions	
34.1	Provided that a Bid is substantially responsive, the Purchaser may waive any non-conformities or omissions in the Bid that do not constitute a material deviation.
34.2	Provided that a Bid is substantially responsive, the Purchaser may request that the Bidder submit the necessary information or documentation within a reasonable period of time, to rectify nonmaterial nonconformities or omissions in the Bid related to documentation requirements. Such omission shall not be related to any aspect of the price of the Bid. Failure of the Bidder to comply with the request may result in the rejection of its Bid.
34.3	Provided that the Bid is substantially responsive, the Purchaser shall correct arithmetical errors on the following basis:
a.	If there is a discrepancy between the unit price and the total price per item that is obtained by multiplying the unit price and quantity, the unit price shall prevail and the total price per item will be corrected unless in the opinion of the Purchaser there is an obvious misplacement of the decimal point in the unit price, in which case the total price as quoted shall govern and the unit price shall be corrected.
b.	If there is a discrepancy between the Total Amount and the sum of the Total price per item, the sum of the total price per item shall prevail and the Total Amount will be corrected.
34.4	If the Bidder that submitted the lowest evaluated Bid does not accept the correction of errors, its Bid shall be disqualified and its Bid Security shall be forfeited.
35. Preliminary Examination of Bids	
35.1	The Purchaser shall examine and confirm that the following documents and information have been provided in the Bid. If any of these documents or information is missing, the Bid shall be rejected.
a.	Bid Form, in accordance with ITB 12.1 (a);
b.	Price Schedules, in accordance with ITB 12.1 (a);
c.	Bid Security, in accordance with ITB 22.
36. Examination of Terms and Conditions; Technical Evaluation	
36.1	The Purchaser shall examine the Bid to confirm that all terms and conditions specified in the GCC and the SCC have been accepted by the Bidder without any material deviation or reservation.
36.2	The Purchaser shall evaluate the technical features of the Bid submitted in accordance with ITB 20, to confirm that all requirements specified in Section V, Schedule of Supply of the Bidding Documents have been met without any material deviation or reservation.
36.3	If, after the examination of the terms and conditions and the technical evaluation, the Purchaser determines that the Bid is not substantially responsive in accordance with ITB 33, the Bid shall be rejected.

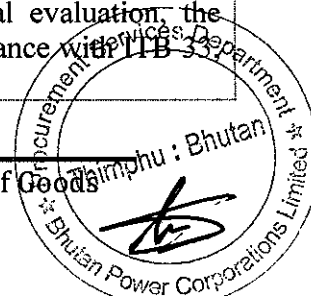

36.4	No conditional offer(s) shall be allowed. A bid with conditional offers shall be rejected
37.	Conversion to Single Currency
37.1	For evaluation and comparison purposes, the Purchaser shall convert all bid prices, expressed in amounts in various currencies into a single currency and use the exchange rates specified in the BDS.
38.	Margin of Preference
38.1	A margin of preference may apply to domestic goods manufactured in Bhutan as provided for in the BDS. To avail a margin of preference, the Bidder shall provide a value addition certificate from the Ministry of Economic Affairs.
39.	Detail Evaluation of Bids
39.1	The Purchaser shall evaluate each Bid that has been determined, up to this stage of evaluation, to be substantially responsive.
39.2	To evaluate a Bid, the Purchaser shall only use all the factors, methodologies and criteria defined in this ITB 39.No other criteria or methodology shall be permitted.
39.3	To evaluate a Bid, the Purchaser shall consider the following:
a.	Evaluation shall be done for Items or Lots, as specified in the BDS;
b.	The Bid Price, as quoted in accordance with ITB Clause 16;
c.	Price adjustment for correction of arithmetic errors in accordance with ITB 34.3;
d.	Price adjustment due to discounts offered in accordance with ITB Clause 16.4;
e.	Adjustments due to the application of the evaluation criteria specified in the BDS from amongst those set out in Section III, Evaluation and Qualification Criteria; and
f.	Adjustments due to the application of a margin of preference, in accordance with ITB Clause 38, if applicable.
39.4	The Purchaser's evaluation of a Bid shall exclude and not take into account any allowance for price adjustment during the period of execution of the contract, if provided in the bid.
39.5	The Purchaser's evaluation of a Bid may require the consideration of other factors in addition to the Bid Price quoted in accordance with ITB Clause 16. These factors may be related to the characteristics, performance, and terms and conditions of purchase of the Goods and Related Services. The effect of the factors selected, if any, shall be expressed in monetary terms to facilitate comparison of Bids, unless otherwise specified in Section III, Evaluation and Qualification Criteria. The factors, criteria and the methodology of application shall be

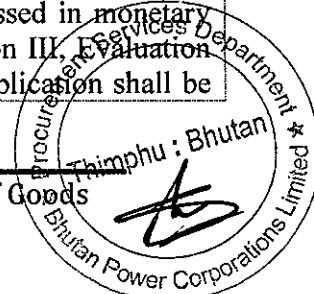

Section I-Instructions to Bidders

	as specified in ITB 39.3 (e).
39.6	If so specified in BDS, Goods are grouped in two or more lots, the Purchaser will evaluate Bids on the basis of LOT WISE or a combination of Lots and the Purchaser shall award one or multiple lots to more than one Bidder.
40.	Comparison of Bids
40.1	The Purchaser shall compare all substantially responsive Bids to determine the lowest evaluated Bid, in accordance with ITB 39.
40.2	If the Bid price of the lowest evaluated Bid appears abnormally low, high and/or seriously unbalanced price as compared to other Bidders or past rates, then the Purchaser may require the Bidder to produce written explanations of, justifications and detailed price analyses for any or all items offered. Such explanations may include, but are not limited to, details of the method by which the Goods and Related Services are to be provided, the technical solutions chosen, exceptionally favorable conditions available to the Bidder for the execution of the Contract, and the originality of the Goods proposed by the Bidder. After objective evaluation of the explanations, justifications and price analyses, if the Purchaser decides to accept the Bid with an abnormally low and/or seriously unbalanced price, the Purchaser shall require that the amount of the Performance Security stipulated in ITB 48 be increased at the expense of the Bidder to a level sufficient to protect the Purchaser against financial loss in the event of default of the successful Bidder under the Contract.
41.	Post qualification of the Bidder
41.1	The Purchaser will determine to its satisfaction whether the bidder selected as having submitted the lowest-evaluated and substantially responsive Bid is qualified to satisfactorily perform the Contract.
41.2	The Purchaser will determine the reasonability of the Bid Prices based on the past purchase rate and the prevailing market rate during the evaluation.
41.3	The determination based upon an examination of the documentary evidence of the bidder's qualifications submitted by the bidder, pursuant to ITB 19, as well as such other information as the Purchaser deems necessary and appropriate.
41.4	If required, the Purchase may carry out the inspections of the Bidder's factories to assess the production, technical, financial, and manpower capacity of the Bidder to perform the Contract. The Purchaser shall notify in advance of the date in writing on which the inspection will be made. If the Bidder does not meet the required capacity as assessed by the inspection team, the bid shall be rejected
41.5	An affirmative determination shall be a prerequisite for award of the Contract to the bidder. A negative determination will result in rejection of the bidder's Bid, in which event the Purchaser shall proceed to the next lowest evaluated Bid to make a similar determination of that Bidder's capabilities to perform satisfactorily.

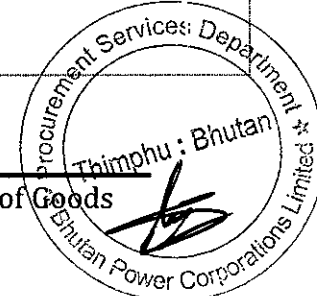

42. Contacting the Purchaser	
42.1	Subject to ITB 31, no bidder shall contact the Purchaser on any matter relating to its Bid, from the time of bid opening to the time the Contract is awarded.
42.2	Any effort by a Bidder to influence the Purchaser in the Purchaser's decisions in respect of bid evaluation, bid comparison or Contract awards will result in the rejection of the bidder's Bid.
43. Purchaser's Right to Accept Any Bid and to Reject Any or All Bids	
43.1	The Purchaser reserves the right to accept or reject any Bid and to annul the bidding process and reject all Bids at any time prior to award of Contract, without thereby incurring any liability to the affected bidder or bidders or any obligation to inform the affected bidder or bidders of the ground for the Purchaser's action.
F. Award of Contract	
44. Award Criteria	
44.1	The Purchaser will award the Contract to the successful bidder whose Bid has been determined to be the lowest-evaluated responsive Bid, provided further that the bidder is determined to be qualified to satisfactorily perform the Contract.
45. Purchasers Right to Vary Quantities at Time of Award	
45.1	At the time the Contract is awarded, the Purchaser reserves the right to increase or decrease the quantity of Goods and Related Services specified in Section V, Schedule of Supply, provided this does not exceed the percentages indicated in the BDS, and without any change in the unit prices or other terms and conditions of the Bid.
46. Notification of Award	
46.1	The Purchaser will notify the successful bidder in writing that its Bid has been accepted.
46.2	Until a formal Contract is prepared and executed, the notification of award shall be binding on the Supplier.
47. Signing of Contract	
47.1	Within 15 (Fifteen) days from the date of issue of the notification of award of contract, the successful bidder are required to come and sign, date and seal the contract agreement at the office as specified in BDS.
47.2	Where the contract is not signed by both parties simultaneously:
a.	The Purchaser shall send to the successful bidder two original copies of (1) the full agreed contract and (2) the letter of acceptance, each copy to be signed by the bidder or its duly authorized representative, together with the date of signature;
b.	The letter of acceptance shall indicate the deadline by which it must be accepted as specified in BDS;

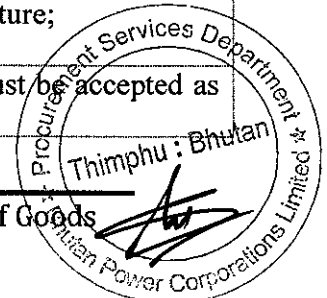

Section I-Instructions to Bidders

	c.	The successful bidder, if agrees to conclude the contract, must sign and date all original copies of the contract and letter of acceptance and return one copy of each to the Purchaser before the expiry of the deadline indicated in the letter of acceptance;
	d.	Failure of the successful bidder to accept the award/ sign the contract shall constitute sufficient grounds for the annulment of the award and forfeiture of the bid security.
47.3		Notwithstanding ITB 47.1 above, in case signing of the Contract Agreement is prevented by any export restrictions attributable to the Purchaser, to Bhutan, or to the use of the products/Goods, systems or services to be supplied, where such export restrictions arise from trade regulations from a country supplying those products/Goods, systems or services, the Bidder shall not be bound by its Bid, always provided, however, that the Bidder can demonstrate to the satisfaction of the Purchaser that signing of the Contract Agreement has not been prevented by any lack of diligence on the part of the Bidder in completing any formalities, including applying for permits, authorizations and/or licenses necessary for the export of the products/Goods, systems or services under the terms of the Contract.
48.	Performance Security	
48.1		Within 15 (Fifteen) working days of the receipt of notification of award of contract, the successful bidder shall furnish the performance security, in accordance with the Conditions of Contract.
48.2		The Performance Security @10% of the supply contract value shall be furnished by the successful bidder in one of the following forms:
	a.	Unconditional bank guarantee issued by the reputed Financial Institution in the form provided for in Section VIII, Contract Forms or another form acceptable to the Purchaser; or
	b.	Banker's Cheque/Cash Warrant, or
	c.	Demand Draft.
48.3		If the institution issuing the Performance Security furnished by the Bidder is located outside the Purchaser's country, the Performance Security shall be counter guaranteed by a correspondent Financial Institutions located in the Purchaser's country to make it enforceable.
48.4		Failure by the successful Bidder to submit the above-mentioned Performance Security shall constitute sufficient grounds for the annulment of the award and forfeiture of the Bid Security. In that event the Purchaser may award the Contract to the next lowest evaluated Bidder whose offer is substantially responsive and is determined by the Purchaser to be qualified to perform the Contract satisfactorily. Such a failure shall be considered as default and all relevant clauses shall apply.

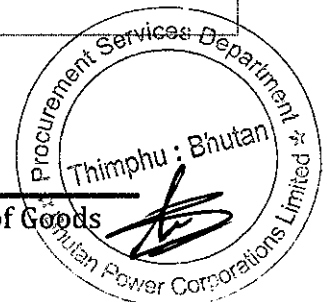

Section II. Bid Data Sheet (BDS)

A. Introduction											
ITB 1.1	The Tender No. is: <i>BPC/PSD/ABC & Line Materials /2021/01 dated February 11, 2021</i>										
ITB 1.1	The Tender Name is: <i>Supply and Delivery of HV ABC, LV ABC, Telescopic Pole Fittings, and Insulators with fittings assembly</i>										
ITB 1.1	The Purchaser is: <i>Procurement Services Department, Bhutan Power Corporation Limited, Yarden Lam, Post Box No. 580, Thimphu, Bhutan.</i>										
ITB 1.1	The number and identification of Lots comprising this tender are: <table border="1" style="margin-left: auto; margin-right: auto;"> <thead> <tr> <th>Lot No.</th> <th>Lot Description</th> </tr> </thead> <tbody> <tr> <td>Lot 1</td> <td>HV ABC</td> </tr> <tr> <td>Lot 2</td> <td>LV ABC</td> </tr> <tr> <td>Lot 3</td> <td>Telescopic Pole Fittings</td> </tr> <tr> <td>Lot 4</td> <td>Insulators with fitting assembly</td> </tr> </tbody> </table>	Lot No.	Lot Description	Lot 1	HV ABC	Lot 2	LV ABC	Lot 3	Telescopic Pole Fittings	Lot 4	Insulators with fitting assembly
Lot No.	Lot Description										
Lot 1	HV ABC										
Lot 2	LV ABC										
Lot 3	Telescopic Pole Fittings										
Lot 4	Insulators with fitting assembly										
B. Bidding Documents											
ITB 8.2	For clarification of Bid purposes only, the Purchaser's address is: Attention: <i>The General Manager.</i> Address: <i>Procurement Services Department, Bhutan Power Corporation Limited, Yarden Lam, Post Box No. 580, Thimphu, Bhutan.</i> Telephone number: <i>+975-2-326289</i> Electronic mail address: <i>nim.dorji@bpc.bt</i> copy to: <i>psdbpc@gmail.com, & alkapradhan@bpc.bt</i>										
C. Preparation of Bids											
ITB 11.1	The language of the Bid is: <i>English</i>										
ITB 2.1(h)	The bidders shall submit a signed Integrity Pact: <i>Yes</i>										
ITB 12.1 (j)	The Bidder shall submit with its Bid the following additional documents: <i>None</i>										
ITB 15.1	Alternative Bids " <i>shall not be</i> " permitted.										
ITB 16.5	The Incoterms edition is: <i>2010 edition.</i>										
ITB 16.6 (a) (i) & (ii)	The price shall be inclusive of all taxes and duties that are applicable both inside and outside the purchaser's country.										
ITB 16.6(b) (i)	The price of the goods quoted shall be DDP (Delivery duty paid), RSD, Malbase/Pasakha (Place of destination). Notwithstanding any possible misinterpretation/ambiguity in interpretation, it is explicitly clarified that the offered prices shall be all inclusive covering all costs including but not limited to transportation, insurance, taxes and duties and any other costs for delivery of the materials to the Purchaser at the designated place of delivery/destination.										
ITB	Add "The Price quoted shall be inclusive of all the taxes and duties that are payable inside										

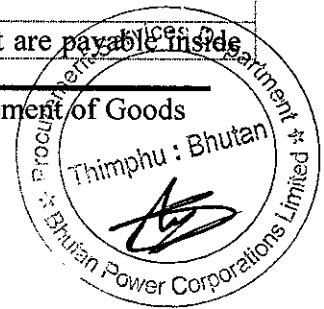

Section II- Bid Data Sheet (BDS)

16.6(b) (ii)	as well as outside purchaser country”.															
ITB 16.6(b) (iii)	Final destination (Project Site) if relevant: Not Applicable.															
ITB 16.7	The prices quoted by the Bidder “shall not” be adjustable.															
ITB 19 (a)	<p>Manufacturer’s Authorization (MA) “is” required</p> <table border="1"> <thead> <tr> <th>Lot No.</th> <th>Item Description</th> <th>MA</th> </tr> </thead> <tbody> <tr> <td>1</td> <td>HV ABC</td> <td>Yes</td> </tr> <tr> <td>2</td> <td>LV ABC</td> <td>Yes</td> </tr> <tr> <td>3</td> <td>Telescopic Pole Fittings</td> <td>Yes</td> </tr> <tr> <td>4</td> <td>Insulators fitting Accessories</td> <td>Yes</td> </tr> </tbody> </table> <p>a) <i>The bid shall be rejected if the Manufacturer’s Authorization is not submitted for which the Manufacturer’s Authorization is required.</i></p> <p>b) <i>The restricted brands are mentioned in the price schedule and bidders are to quote accordingly. No alternative/ substitute brand shall be accepted and shall be considered as non-responsive.</i></p> <p>c) <i>No two brands shall be accepted for one item. Submission of two brands for one item shall be considered as non-responsive.</i></p>	Lot No.	Item Description	MA	1	HV ABC	Yes	2	LV ABC	Yes	3	Telescopic Pole Fittings	Yes	4	Insulators fitting Accessories	Yes
Lot No.	Item Description	MA														
1	HV ABC	Yes														
2	LV ABC	Yes														
3	Telescopic Pole Fittings	Yes														
4	Insulators fitting Accessories	Yes														
ITB 19 (b)	After sales maintenance, repair, spare parts stocking and related services “are not” required, and the Bidder therefore “is not” required to be represented by a suitably equipped and able agent in Bhutan.															
ITB 20.2	<p>Guaranteed Technical Particulars (GTP) is required as follows:</p> <table border="1"> <thead> <tr> <th>Sl. No.</th> <th>Item Description</th> <th>Remarks</th> </tr> </thead> <tbody> <tr> <td>1</td> <td>HV ABC</td> <td>Yes</td> </tr> <tr> <td>2</td> <td>LV ABC</td> <td>Yes</td> </tr> <tr> <td>3</td> <td>Telescopic Pole Fittings</td> <td>No</td> </tr> <tr> <td>4</td> <td>Insulators and fitting Accessories</td> <td>Yes</td> </tr> </tbody> </table> <p>a) <i>The minimum technical specification (where ever required) as indicated in price schedule are detailed out in respective Annexure for respective items under the lot. Any technical deviation shall be brought out in the GTP forms for the items where GTP forms are provided and for the items where GTP forms are not required, the deviation shall be brought out in the deviation sheet provided. If the deviations are not mentioned in GTP and deviation sheet provided, the specification shall be considered as complied with the requirement.</i></p>	Sl. No.	Item Description	Remarks	1	HV ABC	Yes	2	LV ABC	Yes	3	Telescopic Pole Fittings	No	4	Insulators and fitting Accessories	Yes
Sl. No.	Item Description	Remarks														
1	HV ABC	Yes														
2	LV ABC	Yes														
3	Telescopic Pole Fittings	No														
4	Insulators and fitting Accessories	Yes														

	<p>b) <i>The bid for that item(s)/Lot(s) shall be rejected if the GTP is not submitted as specified in Section V, Schedule of Supply where GTP Forms are provided. The catalogue/brochures of the items shall not be considered as GTP of the item. Further, if there are discrepancies between the item catalogue or brochures and offered GTP, then GTP shall prevail.</i></p> <p>d) <i>For the item(s)/Lot(s) of which GTP forms are not provided in Section V, Schedule of Supply of the bidding document, the bidders are requested to submit the catalogue or drawings for individual items. The offered items shall be clearly indicated in the catalogue.</i></p>															
ITB 21.1	The Bid validity period shall be <i>90 days (i.e., till 9th June, 2021)</i> from the date of bid opening.															
ITB 22.1	<p>The amount and currency of the Bid Security are as follows:</p> <table border="1"> <thead> <tr> <th>Sl.#</th> <th>Item Description</th> <th>Amount (Nu.)</th> </tr> </thead> <tbody> <tr> <td>1</td> <td>HV ABC</td> <td>375,000.00</td> </tr> <tr> <td>2</td> <td>LV ABC</td> <td>1,520,000.00</td> </tr> <tr> <td>3</td> <td>Telescopic Pole Fittings</td> <td>119,000.00</td> </tr> <tr> <td>4</td> <td>Insulators with Fittings Assembly</td> <td>87,000.00</td> </tr> </tbody> </table> <p>Preferably Bid Security should be submitted for the individual lots. Combined Bid Security would be also accepted, however, if the combined Bid Security is not sufficient in terms of total amount, the offer for the entire quoted lots would be treated as non-responsive as per ITB 22.4 and not considered for further evaluation.</p>	Sl.#	Item Description	Amount (Nu.)	1	HV ABC	375,000.00	2	LV ABC	1,520,000.00	3	Telescopic Pole Fittings	119,000.00	4	Insulators with Fittings Assembly	87,000.00
Sl.#	Item Description	Amount (Nu.)														
1	HV ABC	375,000.00														
2	LV ABC	1,520,000.00														
3	Telescopic Pole Fittings	119,000.00														
4	Insulators with Fittings Assembly	87,000.00														
ITB 22.3	The Bid Security validity period shall be <i>120 days</i> from the date of bid opening (i.e., 9 th July, 2021).															
D. Submission and Opening of Bids																
ITB 23.1 and 24.1	In addition to the original of the Bid, the number of copies is: <i>One copy.</i>															
ITB 24.3 (d)	The identification of this bidding process is: <i>BPC/PSD/ABC & Line Materials /2021/01 dated February 11, 2021 (Supply and Delivery of ABC, Telescopic Pole Fittings, Distribution Pillars, Insulators and Accessories)</i>															
ITB 25.1	<p>For Bid submission purposes only, the Purchaser's address is:</p> <p>Attention: <i>The General Manager</i></p> <p>Address: <i>Procurement Services Department, Bhutan Power Corporation Limited, Yarden Lam, Post Box No. 580, Thimphu, Bhutan.</i></p>															
ITB 25.1	<p>The deadline for Bid submission is:</p> <p><i>Date: 11th March, 2021</i></p> <p><i>Time: 10:30 hours</i></p>															

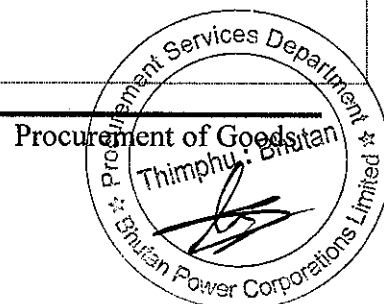

Section II- Bid Data Sheet (BDS)

ITB 29.1	<p>The Bid opening shall take place at:</p> <p>Address: <i>BPC Conference Hall, Bhutan Power Corporation Limited, Yarden Lam, Post Box No. 580, Thimphu, Bhutan.</i></p> <p>Date: <i>11th March, 2021</i></p> <p>Time: <i>11:00 hours</i></p>															
E. Evaluation and Comparison of Bids																
ITB 37.1	<p>Bid prices expressed in different currencies shall be converted into Ngultrum (BTN).</p> <p>The source of exchange rates shall be as published by the Royal Monetary Authority of Bhutan.</p> <p>The date for the exchange rates shall be the date of Bid Opening, as prescribed in ITB 29.1 and the exchange rate shall be TT selling rate.</p>															
ITB 38.1	A margin of five percent (5%) Domestic Preference “ <i>shall not</i> ” apply.															
ITB 39.3 (a)	<p>Bids will be evaluated on following basis:</p> <table border="1" data-bbox="289 913 1437 1144"> <thead> <tr> <th><i>Lot. No.</i></th> <th><i>Item Description</i></th> <th><i>Evaluation and award</i></th> </tr> </thead> <tbody> <tr> <td>1</td> <td>HV ABC</td> <td><i>Lot wise</i></td> </tr> <tr> <td>2</td> <td>LV ABC</td> <td><i>Lot wise</i></td> </tr> <tr> <td>3</td> <td>Telescopic Pole Fittings</td> <td><i>Lot wise</i></td> </tr> <tr> <td>4</td> <td>Insulators and fitting Accessories</td> <td><i>Lot wise</i></td> </tr> </tbody> </table> <p><i>Bids will be evaluated on lot/item bases as indicated above. A lot with an alternative item price shall be rejected and that lot shall not be considered for further evaluation.</i></p> <p><i>For item wise evaluation, Bids will be evaluated for each item and the Contract will comprise the item(s) awarded to the successful Bidder. Items with alternative item price shall be rejected and that particular item shall not be considered for further evaluation. The bidders are required to quote all the sub- items under the item and missing of any sub-item shall be considered as non-responsive for the particular item.</i></p> <p>In case some items are not quoted for a particular lot, the corporation reserves the right to cost load the highest responsive rate of other bidders for the purpose of evaluation of that lot if it was determined that the non-quoted items are not a major component of the lot or do not form an integral element of the lot. Actual order shall however be done based on the lowest rate that has been quoted in that bid package.</p>	<i>Lot. No.</i>	<i>Item Description</i>	<i>Evaluation and award</i>	1	HV ABC	<i>Lot wise</i>	2	LV ABC	<i>Lot wise</i>	3	Telescopic Pole Fittings	<i>Lot wise</i>	4	Insulators and fitting Accessories	<i>Lot wise</i>
<i>Lot. No.</i>	<i>Item Description</i>	<i>Evaluation and award</i>														
1	HV ABC	<i>Lot wise</i>														
2	LV ABC	<i>Lot wise</i>														
3	Telescopic Pole Fittings	<i>Lot wise</i>														
4	Insulators and fitting Accessories	<i>Lot wise</i>														
ITB 39.3 (e)	<p>The adjustments shall be determined using the following criteria from amongst those set out in Section III, Evaluation and Qualification Criteria:</p> <p>(a) Deviation in Delivery schedule: <i>Yes. [Clause 2.2 of Evaluation Criteria (ITB 39.3 (e))]</i></p> <p>(b) Deviation in payment schedule: <i>No [Clause 2.3 of Evaluation Criteria (ITB 39.3 (e))]</i></p>															

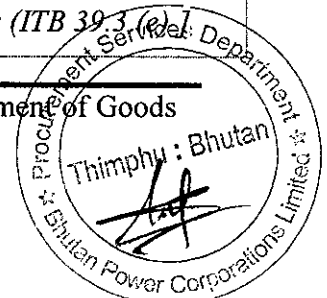

	<p>(c) The cost of major replacement components, mandatory spare parts, and service: <i>No. The cost of spare components, mandatory spares and services if submitted by the Bidder shall not be taken into consideration during the evaluation.</i></p> <p>(d) The availability in Bhutan of spare parts and after-sales services for the equipment offered in the Bid: <i>No</i></p> <p>(e) The projected operating and maintenance costs during the life of the equipment: <i>No.</i></p> <p>(f) The performance and productivity of the equipment offered: <i>Yes. The performance warranty period for the equipment offered will be 12 months from the date of receipt at the place of destination.</i></p>
ITB 39.6	Bidders " <i>shall not</i> " be allowed to quote separate prices for one or more items/lots. [<i>refer to Section III, Evaluation and Qualification Criteria for the evaluation methodology, if appropriate</i>]
F. Award of Contract	
ITB 45.1	The maximum percentage by which quantities may be increased is <i>20% percentage of the contract value</i> . The maximum percentage by which quantities may be decreased is <i>20% percentage of the contract value</i> .
ITB 47.1	The signing of Contract Agreement will take place at: <i>Address: Procurement Services Department, BPC, Yarden Lam, Post Box No. 580, Thimphu, Bhutan.</i>
ITB 47.2	The letter of acceptance must be accepted on or before: 10 (ten) days after the notification of award.

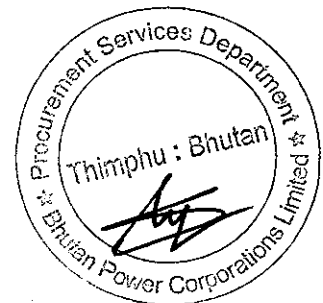

Section III. Evaluation and Qualification Criteria

Table of Contents

Domestic Preference (ITB 38).....2
Evaluation Criteria (ITB 39.3 (e))..... 2
Multiple Contracts (ITB 39.6) 3
Postqualification Requirements (ITB 41.2)..... 3

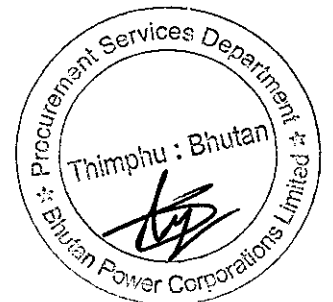

1. Domestic Preference (ITB 38)	
1.1	If the Bidding Data Sheet (BDS) so specifies, in comparing Bids, a margin of preference will be granted to Goods of Bhutanese Origin.
1.2	For application of domestic preference, all responsive Bids will first be classified into the following three categories:
a.	<i>Category I:</i> Goods shall be considered to be of Bhutanese Origin based on the percentage of value addition as prescribed by the Ministry of Economic Affairs, Bhutan;
b.	<i>Category II:</i> All other bids offering Goods manufactured in Bhutan;
c.	<i>Category III:</i> Bids offering Goods manufactured outside Bhutan that have been already imported or that will be imported.
1.3	In the first step, all evaluated bids in each group shall be compared to determine the lowest bid in each group. Such lowest evaluated bids shall be compared with each other and if, as a result of this comparison, a bid from Category I or Category II is the lowest, it shall be selected for the award.
1.4	If as a result of preceding comparison, the lowest evaluated bid is a bid from Category III, for the purpose of further comparison only, an upward five percent (5%) price adjustment will be made to the CIF/CIP/DDP bid prices of Category III bidders. The lowest evaluated bid determined from this last comparison shall be selected for the award.
1.5	Bidders applying for the preference shall provide all supporting documents to prove that the Goods offered by them are from Category I and Category II respectively.
2. Evaluation Criteria (ITB 39.3 (e))	
The Purchaser's evaluation of a Bid may take into account, in addition to the Bid Price quoted in accordance with ITB 16.6, one or more of the following factors as specified in ITB 39.3(e) and in the BDS referring to ITB 39.3(e), using the following criteria and methodologies.	
2.1	Restricted Brands: As per price schedule and Bid Data Sheet [ITB 19(a)]
	BPC has adopted the policy of restricting certain Strategic Critical Items (SC-SKU's) as per the provision of the BPC Procurement Manual to ensure high quality, reduce inventory and to sustain long-term smooth operation and maintenance services. Bidders must ensure that for these lots, only the listed brand names are quoted and effort must be made to source this equipment directly from the manufacturers and or their authorized dealers. Preferred Brands/Restricted Brands are specified in Price Schedule.
2.2	Delivery Schedule (as per Incoterms specified in BDS)
	The Goods are required to be delivered in accordance with and completed as specified in the Section V, Schedule of Supply. No credit will be given to earlier completion. Bids offering late delivery schedules (LDS) will be accepted but the Bids shall be adjusted for the purpose of the bid evaluation only adding at the rate of @one (1) per cent of the bid price for each week of delay to the bid price. Bids offering delivery schedules beyond 1 (one) month of the date specified in Section V, Schedule of Supply shall be rejected.
2.3	Adjustment for Deviations from the Terms of Payments
	Deviation from terms of payment as specified in special condition of contract shall not be permitted. All bids deviating from specified terms of payment will be treated



	as non-responsive.
2.4	Contractual and Commercial Deviations
	The cost of all quantifiable deviations and omissions from the contractual and commercial conditions shall be evaluated. The Purchaser will make its own assessment of the cost of any deviations for the purpose of ensuring fair comparison of Bids.
3. Multiple Contracts (ITB 39.6)	
3.1	The Purchaser shall award multiple contracts to the Bidder that offers the lowest evaluated combination of Bids (one contract per Bid) and meets the post qualification criteria (this Section III, Sub-Section ITB 39.2, Post qualification Requirements)
3.2	The Purchaser shall:
	a. Evaluate only items/lots that include at least the percentages of items per lot and quantity per item as specified in ITB 16.8.
	b. Take into account:
	i. The lowest-evaluated Bid for each lot; and
	ii. The price reduction per lot and the methodology for its application as offered by the Bidder in its Bid.
4. Post qualification Requirements (ITB 41.2)	
4.1	After determining the lowest-evaluated Bid in accordance with ITB 40.1, If required, the Purchaser shall carry out the post qualification of the Bidder in accordance with ITB 41, using only the requirements specified. Requirements not included in the text below shall not be used in the evaluation of the Bidder's qualifications.
	a. Financial Capability The Bidder shall furnish documentary evidence that it meets the following financial requirement(s): <i>Not applicable</i>
	b. Experience and Technical Capacity The Bidder shall furnish documentary evidence to demonstrate that it meets the following experience requirement(s): <i>ISO Certificate; list of previous clients, relevant catalogues, test certificates, list of past performance certificates and manufacturer's profile for all new brands that are introduced in BPC.</i>
	c. The Bidder shall furnish documentary evidence to demonstrate that the Goods it offers meet the following usage requirement(s): <i>Not applicable</i>

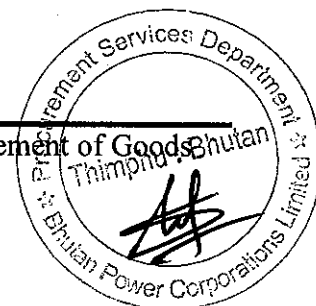

Section IV. Bidding Forms

Table of Contents

Bidder Information Form.....2
Joint Venture (JV) Partner Information Form.....3
Bid Form.....4-5
Deviation Schedule.....6
Bid Security (Bank Guarantee).....7
Manufacturer's Authorisation8
Integrity Pact.....9-11
VPMS Acceptance Form.....12



Bidder Information Form

[The Bidder shall fill in this Form in accordance with the instructions indicated below. No alterations to its format shall be permitted and no substitutions shall be accepted.]

Date: *[insert date of Bid submission:*]

Bid No.: *[.....]*

Page _____ of _____ pages

1. Bidder's Legal Name:
2. In the case of a Joint Venture, Consortium or Association (JV/C/A) legal name of each party:
3. Bidder's actual or intended Country of Registration:
4. Bidder's Year of Registration:
5. Bidder's Legal Address in Country of Registration:
6. Bidder's Authorized Representative Information Name: Address: Telephone/Fax numbers: E-mail Address:
7. Attached are copies of the following original documents: <i>[check the box(es) of the attached original documents]</i> <input type="checkbox"/> Registration of firm named in 1 above, in accordance with ITB 3.1. <input type="checkbox"/> In the case of a JV, letter of intent to form the JV, or the JV agreement, in accordance with ITB 6.1 (e). <input type="checkbox"/> Power of attorney authorizing the signatory of the Bid to sign on behalf of the Bidder.

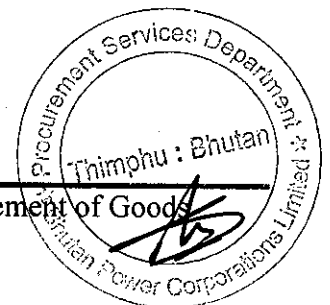

Joint Venture (JV) Partner Information Form

[The Bidder shall fill in this Form in accordance with the instructions indicated below].

Date: *[insert date (as day, month and year) of Bid submission]*

Bid No.: *[insert number of bidding process]*

Page _____ of _____ pages

1. Bidder's Legal Name: <i>[insert Bidder's legal name]</i>
2. JV Party's legal name: <i>[insert JV Party's legal name]</i>
3. JV Party's Country of Registration: <i>[insert JV Party's country of registration]</i>
4. JV Party's Year of Registration: <i>[insert JV Party's year of registration]</i>
5. JV Party's Legal Address in Country of Registration: <i>[insert JV Party's legal address in country of registration]</i>
6. JV Party's Authorized Representative Information Name: <i>[insert name of JV Party's authorized representative]</i> Address: <i>[insert address of JV Party's authorized representative]</i> Telephone/Fax numbers: <i>[insert telephone/fax numbers of JV Party's authorized representative]</i> E-mail Address: <i>[insert e-mail address of JV Party's authorized representative]</i>
7. Attached are copies of the following original documents: <i>[check the box(es) of the attached original documents]</i> <input type="checkbox"/> Articles of Incorporation or Registration of firm named in 2 above, in accordance with ITB 3.1. <input type="checkbox"/> Copy of Agreement between JV Partners.

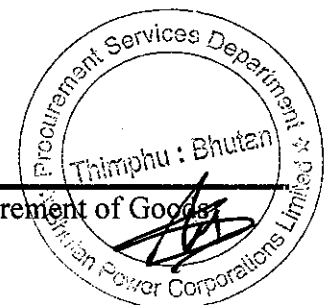

Bid Form

[The Bidder shall fill in this form in accordance with the instructions indicated. No alterations to its format shall be permitted and no substitutions shall be accepted.]

Date:..... *[insert date of Bid submission]*

Invitation for Bid No.:..... *[insert number of IFB]*

To: *[insert complete name of the Purchaser]*

We, the undersigned, declare that:

(a) We have examined and have no reservations to the Bidding Documents, including Addenda No.:..... *[insert the number and date of issue of each addendum];*

(b) We offer to supply in conformity with the Bidding Documents and in accordance with the Delivery Schedules specified in the Schedule of Supply the following Goods and Related Services:..... *[insert a brief description of the Goods and Related Services];*

(c) The total price of our Bid, excluding any discounts offered in item (d) below is: *[insert the Bid Price in words and figures, indicating the various amounts and their respective currencies];*

(d) The discounts offered and the methodology for their application are:

Discounts. If our Bid is accepted, the following discounts shall apply:..... *[Specify in detail each discount offered and the specific item of the Schedule of Supply to which it applies.]*

Methodology of Application of the Discounts. The discounts shall be applied using the following methodology:..... *[Specify in detail the methodology that shall be used to apply the discounts];*

(e) Our Bid shall be valid for a period of **90 days** from the date fixed for the Bid submission deadline in accordance with ITB (insert Sub-Clause 21.1), and it shall remain binding upon us and may be accepted at any time before expiry of that period;

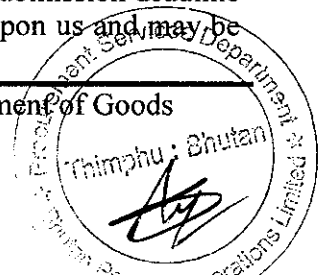

Section IV- Bidding Forms

- (f) If our Bid is accepted, we commit to provide a Performance Security in accordance with ITB (insert Clause 48 and GCC Clause 11) for the due performance of the Contract;
- (g) We are not participating, as Bidders, in more than one Bid in this bidding process, other than any alternative offers submitted in accordance with ITB (insert Clause 15);
- (h) We, including any subcontractors or suppliers for any part of the Contract, have nationality from eligible countries, viz:..... *[insert the nationality of the Bidder, including that of all parties that comprise the Bidder if the Bidder is a JV/C/A, and the nationality each subcontractor and supplier]*
- (i) We have no conflict of interest pursuant to ITB (Insert Sub-Clause 3.2);
- (j) Our firm, its affiliates or subsidiaries - including any subcontractors or suppliers for any part of the contract - has not been declared ineligible by the Purchaser under the laws or official regulations of Bhutan, in accordance with ITB (insert Sub-Clause 4.1);
- (k) The following commissions, gratuities or fees have been paid or are to be paid with respect to the bidding process or execution of the Contract:..... *[insert complete name of each Recipient, its full address, the reason for which each commission or gratuity was paid and the amount and currency of each such commission or gratuity]*

Name of Recipient	Address	Reason	Amount
_____	_____	_____	_____
_____	_____	_____	_____

(If none has been paid or is to be paid, indicate "none.")

- (l) We understand that this Bid, together with your written acceptance thereof included in your notification of award, shall constitute a binding contract between us, until a formal contract is prepared and executed.
- (m) We understand that you are not bound to accept the lowest evaluated Bid or any other Bid that you may receive.

Signed:*[insert signature of person whose name and capacity are shown]*

In the capacity of *[insert legal capacity of person signing the Bid Form]*

Name:*[insert complete name of person signing the Bid Form]*

Duly authorized to sign the bid for and on behalf of: *[insert complete name of Bidder]*

Dated on day of,*[insert date of signing]*

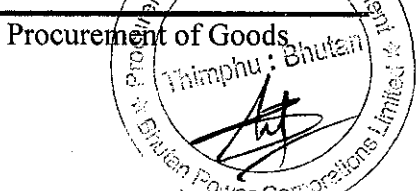

DEVIATION SCHEDULE

The bidder shall specify below, in detail, all deviations from and exceptions to the Bid Document. Any entry shall be referenced to the Bid Document Clause No. To which they refer.

The Bidder shall be deemed to be compliant with the content and intent of the Bid Document except in respect of deviations and exception listed in this Schedule.

No deviation from and exception to the Bid Document shall be made subsequently to the Contract without the written approval of the Employer.

Clause No.	Details of Deviation/ Exception	Reasons for Deviation/ Exception

Declaration: This page and attached.....Pages of deviation from the Bid Document is a complete record of such deviation.

In case of NO DEVIATION is mentioned here and deviation of clauses/specification is mentioned elsewhere, then it will be taken as a deviation.

Signature of Bidder _____

Place & Date _____

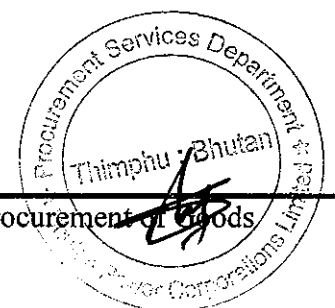

Bid Security (Bank Guarantee)

[The Bank shall fill in this Bank Guarantee Form in accordance with the instructions indicated.]

[insert Bank's Name, and Address of Issuing Branch or Office]

Beneficiary: _____ *[Name and Address of Purchaser]*

Date: _____

BID GUARANTEE No.: _____

We have been informed that *[insert name of the Bidder]* (hereinafter called "the Bidder") has submitted to you its Bid dated (hereinafter called "the Bid") for the execution of *[insert name of Tender]* under Invitation for Bids No. *[insert IFB number]* ("the IFB").

Furthermore, we understand that, according to your conditions, Bids must be supported by a Bid Guarantee.

At the request of the Bidder, we *[insert name of Bank]* hereby irrevocably undertake to pay you any sum or sums not exceeding in total an amount of *[insert amount in figures]* (*[insert amount in words]*) upon receipt by us of your first demand in writing accompanied by a written statement stating that the Bidder is in breach of its obligation(s) under the Bid conditions, because the Bidder:

- (a) has withdrawn its Bid during the period of Bid validity specified by the Bidder in the Form of Bid; or
- (b) having been notified of the acceptance of its Bid by the Purchaser during the period of Bid validity, (i) fails or refuses to execute the Contract ; or (ii) fails or refuses to furnish the Performance Security, if required, in accordance with the Instructions to Bidders.

This guarantee will expire: (a) if the Bidder is the successful Bidder, upon our receipt of copies of the contract signed by the Bidder and the Performance Security issued to you upon the instruction of the Bidder; or (b) if the Bidder is not the successful Bidder, upon the earlier of (i) our receipt of a copy of your notification to the Bidder of the name of the successful Bidder; or (ii) Thirty days after the expiration of the Bidder's Bid.

Consequently, any demand for payment under this guarantee must be received by us at this office on or before that date.

[signature of authorized representative of the bank]



Manufacturer's Authorization

[The Bidder shall require the Manufacturer to fill in this Form in accordance with the instructions indicated. This letter of authorization should be on the letterhead of the Manufacturer and be signed by a person with the proper authority to sign documents that are binding on the Manufacturer. The Bidder shall include it in its bid, if so indicated in the BDS.]

Date: *[insert date of Bid Submission]*

Invitation for Bid No.: *[insert IFB number]*
Alternative No.: *[insert identification No if this is a Bid for an alternative]*

To: *[insert complete name of the Purchaser]*

WHEREAS

We *[insert complete name of the Manufacturer]*, who are official manufacturers of *[insert type of Goods manufactured]*, having factories at *[insert full address(es) of the Manufacturer's factory/ies]*, do hereby authorize *[insert complete name of Bidder]* to submit a Bid in relation to the Invitation for Bids indicated above, the purpose of which is to provide the following Goods, manufactured by us, namely *[insert name and/or brief description of the Goods]*, and subsequently to negotiate and sign the Contract.

We hereby extend our full guarantee and warranty in accordance with the General Conditions of Contract, with respect to the Goods offered by the above firm.

Signed: *[insert signature(s) of authorized representative(s) of the Manufacturer]*

Name: *[insert complete name(s) of the authorized representative(s) of the Manufacturer]*

Title: *[insert title(s) of the authorized representative(s) of the Manufacturer]*

Duly authorized to sign this Authorization for and on behalf of *[insert complete name of the Bidder]*

Dated on the *[insert number]* day of *[insert month]*, *[insert year]*.

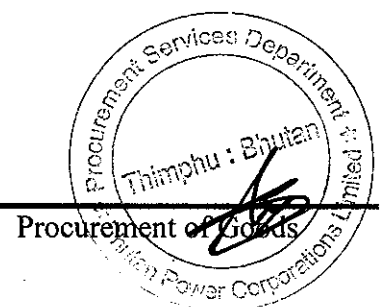

INTEGRITY PACT

1 General:

Whereas *Nim Dorji, General Manager, Procurement Services Department* representing the *Bhutan Power Corporation Limited*, Royal Government of Bhutan, hereinafter referred to as the “**Employer**” on one part, and representing hereinafter referred to as the “**Bidder**” on the other part hereby execute this agreement as follows:

This agreement shall be a part of the standard bidding document, which shall be signed by both the parties at the time of purchase of bidding documents and submitted along with the tender document. This IP is applicable only to “**large**” scale works, goods and services, the threshold of which will be announced by the government from time to time. The signing of the IP shall not apply to framework contracting such as annual office supplies etc.

2 Objectives:

Whereas, the Employer and the Bidder agree to enter into this agreement, hereinafter referred to as IP, to avoid all forms of corruption or deceptive practice by following a system that is fair, transparent and free from any influence/unprejudiced dealings in the **bidding process**¹ and **contract administration**², with a view to:

- 2.1 Enabling the Employer to obtain the desired contract at a reasonable and competitive price in conformity to the defined specifications of the works or goods or services; and
- 2.2 Enabling bidders to abstain from bribing or any corrupt practice in order to secure the contract by providing assurance to them that their competitors will also refrain from bribing and other corrupt practices.

3. Scope:

The validity of this IP shall cover the bidding process and contract administration period.

4. Commitments of the Employer:

The Employer Commits itself to the following:-

- 4.1 The Employer hereby undertakes that no officials of the Employer, connected directly or indirectly with the contract, will demand, take a promise for or accept, directly or through intermediaries, any bribe, consideration, gift, reward, favor or any material or immaterial benefit or any other advantage from the Bidder, either for themselves or for any person,

¹ Bidding process, for the purpose of this IP, shall mean the procedures covering tendering process starting from bid preparation, bid submission, bid processing, and bid evaluation.

² Contract administration, for the purpose of this IP, shall mean contract award, contract implementation, unauthorized sub-contracting and contract handing/taking over.

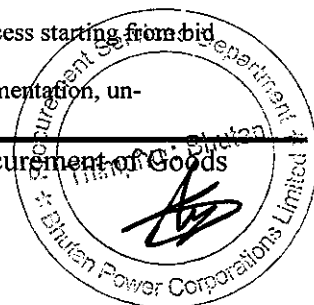

organization or third party related to the contract in exchange for an advantage in the bidding process and contract administration.

- 4.2 The Employer further confirms that its officials shall not favor any prospective bidder in any form that could afford an undue advantage to that particular bidder in the bidding process and contract administration and will treat all Bidders alike.
- 4.3 Officials of the Employer, who may have observed or noticed or have reasonable suspicion shall report to the head of the employing agency or an appropriate government office any violation or attempted violation of clauses 4.1 and 4.2.
- 4.4 Following report on violation of clauses 4.1 and 4.2 by official (s), through any source, necessary disciplinary proceedings, or any other action as deemed fit, including criminal proceedings shall be initiated by the Employer and such a person shall be debarred from further dealings related to the bidding process and contract administration.

5. Commitments of Bidders

The Bidder commits himself/herself to take all measures necessary to prevent corrupt practices, unfair means and illegal activities during any stage of the bidding process and contract administration in order to secure the contract or in furtherance to secure it and in particular commits himself/herself to the following :-

- 5.1 The Bidder shall not offer, directly or through intermediaries, any bribe, gift, consideration, reward, favor, any material or immaterial benefit or other advantage, commission, fees, brokerage or inducement to any official of the Employer, connected directly or indirectly with the bidding process and contract administration, or to any person, organization or third party related to the contract in exchange for any advantage in the bidding process and contract administration.
- 5.2 The Bidder shall not collude with other parties interested in the contract to manipulate in whatsoever form or manner, the bidding process and contract administration.
- 5.3 If the bidder(s) have observed or noticed or have reasonable suspicion that the provisions of the IP have been violated by the procuring agency or other bidders, the bidder shall report such violations to the head of the procuring agency.

6. Sanctions for Violation:

The breach of any of the aforesaid provisions shall result in administrative charges or penal actions as per the relevant rules and laws.

- 6.1 The breach of the IP or commission of any offence (forgery, providing false information, mis-representation, providing false/fake documents, bid rigging, bid steering or coercion) by the Bidder, or any one employed by him, or acting on his/her behalf (whether with or



Section IV- Bidding Forms

without the knowledge of the Bidder), shall be dealt with as per the terms and conditions of the contract and other provisions of the relevant laws, including De-barment Rules.

6.2 The breach of the IP or commission of any offence by the officials of the procuring agency shall be dealt with as per the rules and laws of the land in vogue.

7. **Monitoring and Administration:**

7.1 The respective procuring agency shall be responsible for administration and monitoring of the IP as per the relevant laws.

7.2 The bidder shall have the right to appeal as per the arbitration mechanism contained in the relevant rules.

We, hereby declare that we have read and understood the clauses of this agreement and shall abide by it.

The parties hereby sign this Integrity Pact at _____ on _____.

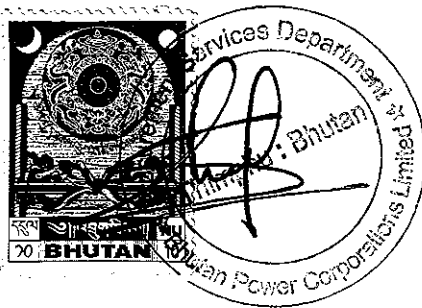

Affix
Legal
Stamp

EMPLOYER

BIDDER/REPRESENTATIVE

CID : 1 1 9 0 4 0 0 1 6 5 4

CID : [] [] [] [] [] [] [] [] [] [] [] []

Witness:

Witness: _____

Name: Alka Pradhan

Name: _____

CID : 1 1 2 0 3 0 0 0 3 0 4

CID : [] [] [] [] [] [] [] [] [] [] [] []

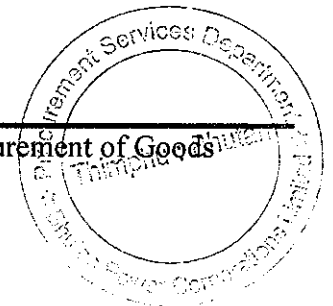

VPMS Acceptance Form

[The Bidder shall fill in this form in accordance with the instructions indicated. No alterations to its format shall be permitted and no substitutions shall be accepted.]

WHEREAS MESSRS (Insert the name of bidder) _____ -- _____
(hereinafter called "the Bidder") License No. _____ having our registered
office at _____ has submitted its bid dated _____.

We hereby agree to abide by the Vendor Performance Management System of BPC or do affirm as follows.

1. We have read and understood all provisions set in the Vendor Performance Management System (VPMS) and we have no reservations to the VPMS document included in the Bidding Documents.
2. We agree to abide by all the provision of VPMS.
3. If our bid is accepted, we agree to be assessed as per the vendor rating methodology adopted by Bhutan Power Corporation Limited.
4. Depending on our performance, we accept the rating of Vendor Performance Index issued and any action taken by Bhutan Power Corporation Limited pursuant to the VPMS.
5. We shall be liable for any breach of this undertaking and non- compliance to the provisions of VPMS.

(Signature of Bidder)

(Signature of witness)

Date:

Date:

Address:

Contact No.:

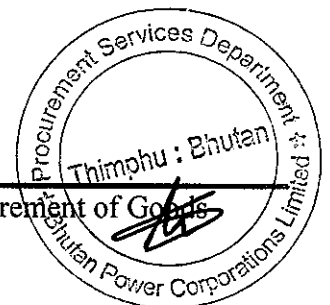

PART 2- Supply Requirement



Section V. Schedule of Supply

Table of Contents

1. Delivery and Completion Schedule..... 3

2. Technical Specifications and Drawings..... 4

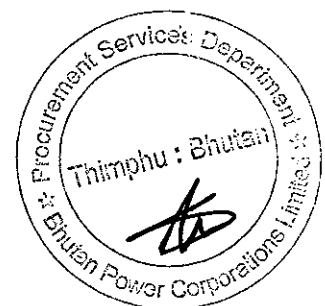

1. Delivery and Completion Schedule

a. The delivery period shall commence from the date of signing contract.

Lot No.	Lot Description	Required Arrival Date of Goods or Completion Date for Related Services
<i>Lot 1</i>	<i>HV ABC</i>	<i>180 days from the signing of contract</i>
<i>Lot 2</i>	<i>LV ABC</i>	<i>180 days from the signing of contract</i>
<i>Lot 3</i>	<i>Telescopic Pole Fittings</i>	<i>90 days from the signing of contract</i>
<i>Lot 4</i>	<i>Insulators with fitting Assembly</i>	<i>90 days from the signing of contract</i>

Location / Destination as specified in BDS –Shall be RSD, Stores at Malbase, Pasakha and Phuentsholing



2. Technical Specifications and Drawings

Table of Content

SI #	Technical Specification	Page No.
1	Section I- Common Technical Requirements	5-26
2	Test Standards	1-3
3	Technical Specification for Lot 1& 2(HV & LV ABC)	1-3
4	Technical Specification for Lot 3 (Telescopic Pole Fittings)	1-2
5	Technical Specification for Lot 5 (Insulators with fitting Assembly)	1-6
6	Table of guaranteed technical particulars (GTP Forms)- bidders to fill up	
7	Price schedule	

Note: Serial no. 6 (Table of guaranteed technical particulars -Bidders to fill up), and serial no 7 (Price Schedule) are enclosed at the end of the bidding document for convenience.



Section I - Common Technical Requirements

1.1 General

In the following sections, this document describes equipment required for the tender. The common technical specifications are to mainly state the general requirements commonly applied for all the Packages. If there is any discrepancy in the requirements between the General Specifications and the Technical Specifications in this Section, the requirements mentioned in Technical Specifications shall prevail.

1.2 Scope of Work

The supply contract includes the design, manufacture, testing, insurance, delivery in complete form (assembly at warehouse if required) unloading and proper handing over the supplies to the Purchaser's Warehouse at Phuentsholing/Pasakha, Bhutan, of the Equipment as specified in the Price Schedule.

All necessary foundation bolts, rag bolts, nuts and washers, grouting packing and the like required for mounting and securing the equipment/assemblies should be included in the supply.

Bidders shall furnish guaranteed particulars in the Schedules enclosed. Drawings of all components shall be provided together with the equipment type and reference number to ensure their identification.

The unloading of the goods (items) in the purchaser's warehouse shall be in the scope of the suppliers.

1.3 Units of Measurement

Metric units of measurement (System International) shall be used on all Contract documentation. Angular measurement shall be in degrees with 90 degrees comprising one right angle.

1.4 Standards

The design material, construction, manufacture, inspection and testing of all equipment supplied under this Specification shall conform to the latest editions of the International Electro-technical Commission (IEC) Specifications and other international standards where the material is not covered by IEC. Other national or international standards are accepted if they promise to confer equal or superior quality and performance than IEC or the specified standards.

The Supplier shall provide to the Purchaser, English language copies of any Standards and Codes of Practice, which the Supplier wishes to use. The Supplier shall provide English language translations of any Standards and Codes of Practice which the Supplier wishes to use and which are in a language other than English.

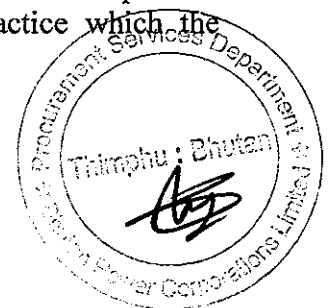

1.5 Language

The English language shall be used on all Contract documents, drawings and calculations and in all correspondence between the Supplier and the Purchaser. Any documents and drawings submitted by the Supplier in the language other than English to the Purchaser will be returned to the Supplier without review by the Purchaser.

1.6 Site Conditions

1.6.1 The conditions for the design of the equipment are as follow:

Basic Design Parameters	Basic Design Value
Altitude	2400 metres
Ambient Air Temperature : minimum	-10°C
Maximum	+40°C
Average Annual Isokeraunic Level	75 thunderstorm days
Average Annual Rainfall & Period	1400 mm (May to September)
Climate	Varied (From tropical to severe winters)
Relative Humidity	20 – 100%
Seismic Acceleration : Horizontal	0.1 g
Vertical	0.05 g
Snow Incidence and period	150 –300 mm (December to March)
Wind Pressure : Conductors	45 kg/m ²
Towers, Supports	195 kg/m ²

1.6.2 Special Conditions

The equipments under this tender shall be designed for 2400m and accordingly shall the equipment/components shall be altitude corrected to 2400m.

1.7 Electrical Design Parameters

The electrical parameters of the equipments in accordance with relevant IEC and IS standards for 33kV and below are shown in following tables.

Medium Voltage

Nominal System Voltage	kV	33	11	6.6
Nominal System Frequency	Hz	50	50	50
Maximum System Voltage	kV	36	12	7.2
Rated Impulse withstand voltage (Peak)	kV	170	75	60
Rated one minute power frequency withstand voltage (rms)	kV	70	28	20
Rated one second short time current (rms)	kA	16	20	20

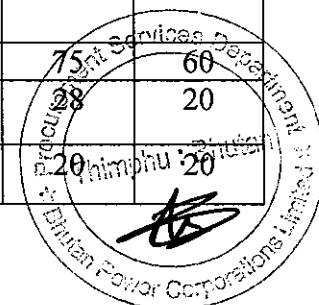

Rated short circuit withstand current (peak)	kA	40	50	50
Creepage Distance	(mm/kV)	25	25	25

Low Voltage

Insulation parameters- Low Voltage

Nominal System Voltage	V	400/230
Nominal System Frequency	Hz	50
Maximum System Voltage	V	424/244 ¹
Rated one minute power frequency withstand voltage (rms)	V	3000
Rated impulse withstand voltage (peak)	kA	7500

Note 1: Phase to Phase / Phase to Neutral

System Variation

Parameters permissible at 75 °C		Variation
Voltage Regulation of MV System	33,11,6.6 kV	±10%
Voltage Regulation of LV System	400/230 V	±6%
System Frequency	50 Hz	-2%, +1% ¹
Parameters permissible at 75 °C		Variation

Note 1: Maintain the System frequency between 49.0-50.5Hz.

1.7.1 De-rating

Since various standards or recommendations enforce validity limits on device characteristics, therefore the values mentioned in this specification are for the normal condition of use i.e. below 1000 m. Beyond these limits, it is necessary to deduce certain values, in other words to de-rate the device. De-rating must be considered;

- For insulation level of external insulation.
- For electrical clearances of two conductive parts measured through air.

1.7.2 Basic Insulation Level (BIL) De-rating According to Altitude

For installation at an altitude higher than 1000 m, the correction method recommended in IEC 60694 is convenient to use for purpose of the determination of withstand test voltages.

1.7.3 Electrical Clearance De-rating According to Altitude

If the equipment is specified for operation at an altitude higher than 1000 m, the clearance requirements shall be increased by 1.25% for every 100 m by which the altitude exceeds 1000 m. Requirements are given for phase-to-earth; phase-to-neutral and phase-to-phase clearance.

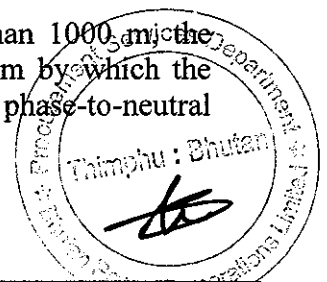

1.8 Spare Parts, Tools and Appliances

The bidder shall attach the spares, special tools and/ or appliances which are recommended.

The Purchaser may order all, none or any of the recommended items. Those ordered shall be delivered not later than the date of receipt of the last shipment of the associated item of plant. The price of the items shall be subject to the same price conditions as the associated item of plant.

All spares shall be interchangeable with the original parts. They shall be treated and packed for long term storage under the climatic conditions of site.

Each item shall be clearly and permanently labelled on the outside of its container with its description and purpose. When several items are packed in one case, a general description of the contents shall be given on the outside of the case. Spare parts shall not be shipped in the same cases as components, which are used for erection. The cases shall be clearly labelled to indicate that they contain spare parts or tools and each tool or appliance shall be clearly marked with its size and purpose.

All case containers or other packages are liable to be opened for inspection and checking on site.

The cost of recommended spares, special tools (other than those specified in the BOQ) will not be taken into consideration when comparing bids.

1.9 Electrical Power Supplies

a) Power Supplies

Power supplies for plant and equipment shall be:

- i. 400 V, 3 phase, 4-wire, 50 Hz for power.
- ii. 230 V, 1 phase, 50 Hz for lighting, indication, and anti-condensation heaters.

48/110 V DC for relays, essential indication, CB spring charging, controls/ protection, alarms, CB tripping and closing.

b) Miniature Circuit Breakers

Means shall be provided for protection and isolation of circuits associated with protection, control and instruments. They shall be of approved type and grouped, as far as possible, according to their functions. They shall be clearly labelled both on the panels and the associated wiring diagrams.

Miniature circuit breakers shall be of the thermal and magnetic tripping type, and comply with IEC 60898 and IEC 60947-2.

c) Instruments

All electrical instruments and meters shall comply with IEC 60051 and IEC 61010 and, unless otherwise specified, shall be of industrial grade accuracy. Three-phase power



measuring instruments shall be of the three-phase unbalanced load pattern wherever the current and Voltage references permit. Energy meters shall be three phase four wire having maximum demand indicator, RS485 port and optical port.

All indicating and recording instruments shall be flush mounted in dust proof cases complying with IEC 60068 and dimensions to IEC 61554.

The size of all indicating instruments shall be 96 mm square with long scale and instruments supplied from transducers shall have 4-20 mA movements. Running hour meters shall have 6 digit cyclo-meter type indicators.

Instrument dials shall be white with black markings. A red line shall be drawn on each scale to represent rated conditions. Bezels shall have uniform semi-gloss black high-grade finish.

The movements of all electrically actuated instruments shall be of the deadbeat type. Instruments shall be provided with a readily accessible zero adjustment wherever possible.

d) Terminals

Moulding materials shall be self-extinguishing or resistant to flame propagation, substantially non-hygroscopic and shall not carbonise when tested for tracking. The insulation between any terminal & framework or between adjacent terminals shall withstand a test of 2 kV rms. for one minute. The mouldings shall be mechanically robust to withstand handling while making terminations.

All terminals shall be mounted in accessible positions. Adjacent terminals shall be adequately spaced with respect to each other and to the incoming cable gland plate. Separate terminations shall be provided on each terminal strip for the cores of incoming and outgoing cables including all spare cores.

Terminal blocks for CT and VT secondary leads shall be provided with test links and isolating facilities. Terminals provided for current transformers shall incorporate facilities to enable secondary windings to be short-circuited without disturbing fixed wiring and earthing facilities.

Terminations for circuits operating at Voltages greater than 60 V shall be protected by transparent insulating covers marked with the working Voltages.

DC circuit terminals shall be segregated from AC terminals.

Unless otherwise specified, all the terminal blocks except the terminal blocks for CTs shall be suitable for connecting minimum two 2.5 sq.mm copper conductors of the external cables at each connecting point. The terminal blocks for CTs and PTs shall be suitable for connecting minimum of 4.0 sq. mm and 2.5 sq. mm copper conductors respectively.

All spare contacts and terminals of the panel mounted equipment and devices shall be wired to terminal blocks.

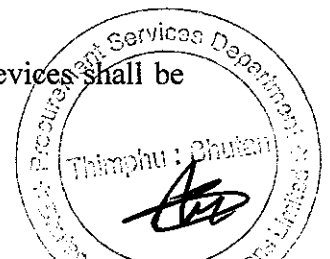

The terminal assemblies shall give the required number of ways plus 20% spare with a minimum of 5 terminals. These shall be uniformly distributed on all rows of terminal blocks.

e) Panel Wiring

All wiring shall be carried out with 1100 V grade, single core, stranded copper conductor wires with FRLS PVC insulation and shall be Vermin, rodent proof. The minimum size of the stranded copper conductor used for panel wiring shall be as follows:

- a) All circuits except CT circuits : 1.5 mm² per lead.
- b) CT Circuit : 2.5 mm² per lead.

The minimum number of strands per conductor shall be seven. Extra flexible wires shall be used for wiring of devices mounted on moving parts such as swinging panels and doors.

The wiring shall be bound and supported by clamping, roughing or lacing. Spiral wrapping will not be accepted. Wire ways shall not be more than 50% full. Adequate slack wire shall be provided to allow for one re-stripping and reconnection at the end of each wire. When screened cables or wires are necessary, an insulating sheath shall be included.

Wiring and supports shall be of fire resistant material.

Wiring shall only be jointed or teed at terminals. Terminals of the clamp type shall not have more than two wires connected.

f) Wire Colour Code

Wire colours shall be as follows:

Colour	Purpose
Red	R-phase connections in current and Voltage transformer circuit only
Yellow	Y-phase connections in current and Voltage transformer circuits only
Blue	B-phase connections in current and Voltage transformer circuits only.
Green with Yellow Stripes	Connections to earth
Black	AC neutral connections, earthed or unearthed, connected to the secondary circuits of current and Voltage transformers.
Any other Colours	AC connections other than those above.

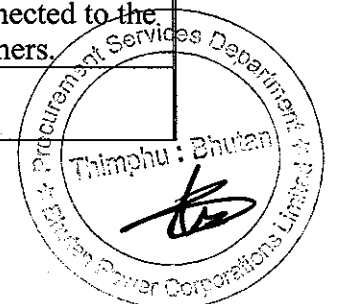

Alternatively, where equipment is wired in accordance with a manufacturer's standard diagram, wiring may be carried out in a single colour except that all connections to earth shall be green with yellow stripes.

g) Terminations and Ferrules

The ends of every wire and every cable tail shall be fitted with numbered ferrules of white with alpha numbers clearly engraved in black.

Moisture and oil resisting insulating material shall be used. The ferrules shall be of the interlocking type and shall grip the insulation firmly.

Wires and terminals associated with tripping circuits shall be distinctively marked.

h) Electrical Insulation

Insulating materials shall be finished to prevent deterioration of their qualities under the specified working conditions.

Plastics, elastomers, resin-bonded laminates and inorganic materials shall be of suitable quality selected from the grades or types in the appropriate IEC Standard.

All cut or machined surfaces and edges of resin-bonded laminates shall be cleaned and then sealed with an approved Varnish as soon as possible after cutting.

i) Electronic and Control Equipment

Equipment shall be capable of withstanding randomly phased transient over-voltages of either polarity on the power supply or interruptions of the power supply without damage or impairment to the equipment's subsequent performance. In the case of controls, no mal-operation shall occur.

Where manufacturers require that electronic equipment supplied under this Contract should not be subjected to insulation resistance tests ("Meggering"), suitable warning notices shall be provided and installed in appropriate locations.

No thermionic valves shall be used in the equipment. Wherever possible, integrated circuits shall be used.

It shall be possible to remove/replace card from/to electronic equipment without damage and without interfering with the operation of the rest of the equipment or system. If necessary, consideration should be given to switching off the supplies locally to a card to prevent inadvertent interference to the equipment or system during removing/replacing a card.

j) Alternating Current Supply Practice

Double-pole switches shall be used to break single-phase ac mains supplies. For multi-phase supplies, each phase shall be switched simultaneously and the neutral should



preferably not be switched. If it is switched, it shall be opened after and closed before the phase-lines.

All mains circuits shall be protected only in the phase-lines by MCBs of suitable rating or by other suitably approved protective devices. The neutral shall be connected by a removable link located near the protective devices.

All main transformers shall have an electrostatic screen, which shall be earthed.

k) Direct Current Supply Practice

Double pole switches shall be used to break dc supplies, one pole for the positive line and one pole for the negative.

DC circuits shall be protected by MCBs of suitable rating installed in both positive and negative lines.

Measures shall be taken to prevent arcing across switches or relay contacts which are required to break inductive circuits (e.g. bypass diodes or capacitors connected across coils).

Power supply bus bars in cubicles shall be shrouded.

The duplicate auxiliary power supply feeders shall be provided in Control panels. Auto-changeover facility in DC DB shall be provided so that in case of failure of one power source, other shall cut in automatically. The protective relays shall not give a trip signal for momentary loss of control Voltage or during changeover of control Voltage.

l) Batteries

Electronic equipment shall not use local internal batteries unless the approval has been obtained. Where approval is given, batteries used inside equipment shall be of the totally sealed, leak-proof type.

m) Earthing

Provision shall be made for earthing all equipment intended for connection in an ac mains supply.

All structural metal work and metal chassis shall be connected to earth. Earthing conductors shall be at least equal in cross-sectional area to the supply conductors and shall be capable of carrying the fault current for 1 second.

n) Anti-Condensation Heaters

Any items of electrical equipment which are liable to suffer from internal condensation (due to atmospheric or load variations) shall be fitted with heating devices suitable for electrical operation at 230 Volts ac, 1 phase, 50 Hz of sufficient capacity to raise the internal ambient temperature by 5°C. The electrical apparatus so protected shall be designed so that the maximum permitted rise in temperature is not exceeded if the

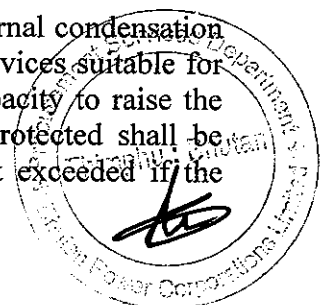

heaters are energised while the apparatus is in operation. Where fitted, a suitable terminal box and control switch shall be provided and mounted in an accessible position. A thermostat shall be provided in the heater control circuit to cut-off the heater at 45° C.

o) Interior lighting and Receptacles

The panels shall be provided with a compact fluorescent lamp (CFL) lighting fixture (11 W) rated for 240 V, 1 phase, 50 Hz supply for the interior illumination of the panel during maintenance. Switching of the fitting shall be controlled by the respective panel door switch. All CFL lamps shall be with pin type holder.

The panels shall be provided with a 230 V, 1 phase, 50 Hz, 6 Amps, 3 Pin receptacle with switch. The receptacle with switch shall be mounted inside the panel at a convenient location.

1.10 Materials and Finishes

1.10.1 General

Unless otherwise provided for in the Contract, all materials, fixtures, fittings, and supplies furnished (hereafter called "materials") shall be new and of standard first grade quality. All assembly and construction work shall be done in a neat and professional manner. Materials shall be free of defects. Materials shall be brought to site only after inspection and issuance of proper dispatch clearance. The dispatch clearance shall be issued within three working days after the inspection from the BPC head office. The local materials like bricks, sand aggregates shall be tested in the local laboratories before bulk supply.

All of the plant, whether temporary or permanent, shall be in accordance with the Contract with respect to character, type, construction, constituent substances, weight, strength, shape, dimensions, etc.

In choosing materials and their finishes, due regard shall be given to the harsh climatic conditions which can occur in the area. Some relaxation of the following provisions may be permitted where equipment is hermetically sealed, but weatherproof materials should be used wherever possible.

All structural members, nuts and bolts shall be galvanised and shall conform to the requirements.

1.10.2 Surface Coating and Galvanising

All ferrous metalwork shall be provided with an effective galvanised or corrosion resistant paint treatment applied in accordance with the best trade practice. The paint treatment for each application shall be selected from the 'Paint Procedure' described in subsequent paragraphs.

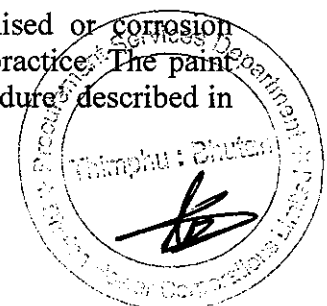

The formulation and application procedure for the paint shall be as recommended by the manufacturer for the appropriate exposure conditions.

Coatings shall not be applied before vessels and chambers have passed any required pressure or vacuum tests. Precautions shall be taken to prevent corrosion occurring in the period of time between cleaning of the steel and commencing the painting.

Adequate amounts of each type and colour of finish coat as applied to the major equipment items shall be provided for "touch-up" purposes.

The colour of equipment shall be painted with RAL 7032 (exterior) and glossy white (interior).

1.10.3 Paint Procedure

- (a) For Mild Steel Items Exposed to Weather:
 - (i) Blast clean.
 - (ii) 1st coat - Inorganic zinc primer to give a dry film build of not less than 75 microns.
 - (iii) 2nd coat - Chlorinated Rubber to give a dry film build of not less than 100 microns.
 - (iv) 3rd coat - Chlorinated Rubber to give a dry film build of not less than 75 microns.
- (b) Mild Steel Items Immersed in Oil :
 - (i) Blast clean.
 - (ii) 1st and 2nd coats - Epoxy paint treatment system in accordance with coating manufacturer's recommendation for oil immersion.
 - (iii) Total dry film build thickness shall not be less than 350 microns.

1.10.4 Galvanising

Galvanising shall be applied by the hot dipped process generally in accordance with ASTM A 123-78 for structural steel and ASTM A 153-73 for iron and steel hardware.

For structural steel, galvanising shall average not less than 0.61 kg/m^2 (no individual specimen shall show less than 0.55 kg/m^2) except for 6.35 mm and heavier materials in which case galvanising shall average not less than 0.702 kg/m^2 (no individual specimen shall show less than 0.61 kg/m^2).

For iron and steel hardware, galvanising shall be in accordance with Table 1 of ASTM A 153-73.

The zinc coating shall be smooth, clean, of uniform thickness and free from defects. The preparation for galvanising and the galvanising itself shall not adversely affect the mechanical properties of the coated material.

1.10.5 Castings

All castings shall be free from blowholes, flaws and cracks as far as is practicable. No welding, filling or plugging of defective parts shall be done under any circumstances. All cast-iron shall be of close-grained quality approved by the Engineer.

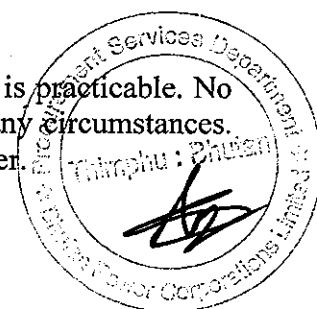

1.10.6 Welding

All joints shall be bolted joints and welded joints shall not be permitted either during the design stage or the construction stage. However, during erection in case of additional unforeseen requirements by the Employer, if welding needs to be resorted to, the same shall be done with prior approval of the Engineer, and shall conform to BIS specifications. In such a case, the Contractor shall specifically indicate the location and purpose along with the proposed methodology for welding for the Engineers' approval. The welding shall be carried out by a certified welder who have undergone minimum of certificate level training in this trade.

1.10.7 Nuts and Bolts

Nuts and bolts for incorporation in the plant shall conform to ISO Metric. Other sizes or threads may be permitted only for threaded parts not to be disturbed once manufacturing is complete. Each bolt shall have rolled threads, one hexagonal nut and two washers. Thread length shall be 50 percent of bolt length or maximum 150 mm.

All steel bolts and screwed rods shall be galvanised including the threaded portions. All associated nuts shall be galvanised with the exception of the threads which shall be oiled. The thickness of zinc coating shall be not less than 0.45 kg/sq. metre of surface area.

All bolts, nuts and washers shall be of non-corroding material where they are in contact with non-ferrous parts in conductor clamps and fittings and elsewhere where specifically required by the Purchaser.

1.11 Packing and Shipping

1.11.1 The goods/materials shall not be shipped/ dispatched unless dispatch clearance from Purchaser/Engineer is issued. The dispatch clearance will be issued from the BPCs office after the inspectors submits its inspection report to BPC, within 4 working days after the submission of the report.

1.11.2 Any items liable to be damaged in transit shall be effectively protected and securely fixed in their cases. All cases of over 2 tonnes shall be marked to show where slings should be placed.

1.11.3 All cases shall be clearly identified giving particulars of manufacturer's name and type of equipment. All identification marks on the outside of cases shall be waterproof and permanent. All electrical equipment shall be adequately sealed and desiccating agents used where necessary to prevent damage from condensation. All equipment shall be packed and protected, bearing in mind that it will be shipped to a harsh environment, that a considerable period may elapse between its arrival on site and it's unpacking and that covered storage may not always be possible.

1.11.4 All wood and other materials used in packing cases shall be insect free. Adequate protection and precautions are to be taken to exclude termites and other vermin, noxious insects, larvae or fungus from the packing materials or plant. All contents are to be clearly marked for easy identification against the packing list.

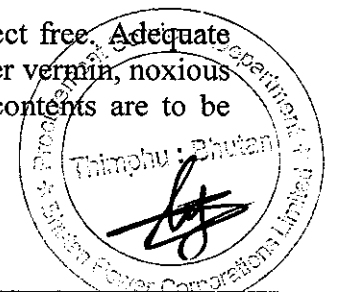

1.11.5 The Supplier shall protect all steelwork before shipment, to prevent corrosion and/ or damage. Bundles of steel sections shall be properly tied together by an approved method and care shall be taken to ensure that they are robust and that they can be handled easily during shipment.

1.11.6 Bolts and nuts shall be double bagged and crated for shipment. Crating of dissimilar metals is not acceptable.

1.11.7 Packing cases where used, shall be strongly constructed and in no case shall timber less than 25 mm in thickness be used. The contents of packing cases shall be securely bolted or fastened in position with struts or cross battens. Cross battens supporting weight in any direction shall not rely for their support on nails or screws driven lengthwise into the grain of the wood, but shall be supported by cleats secured from inside.

1.11.8 The following information shall be marked on the containers/cartons as well as boxes:

- a) Supplier's name, Project title and Contract reference
- b) Identification number
- c) Net/Gross weight
- d) Purchaser's name with other despatch particulars such as destination.

Sl. No.	Description	Marking
1	Cables	Every 1 meter Consecutively

1.12 Cable / Conductor Drums

1.12.1 HV Cables shall be supplied in a steel drum. The covers with wood is acceptable. LV Cables and bare conductors shall be wound on non-returnable seasoned wooden drums provided with lagging of adequate thickness and treated to an approved international standard by vacuum impregnation with copper-chrome-arsenate (CCA) preservative to resist rotting and termite and fungus attacks. Drums with an outside diameter exceeding 2.0 metres and an outside width exceeding 1.4 metres shall not be used. The central hole of the drums shall be reinforced with a steel plate of thickness not less than 10 mm, or be fitted with suitable steel hub bushing to suit an axle diameter of 95 mm.

1.12.2 The drums shall be new and sturdy in construction so as to withstand several times loading and unloading, transport on rough roads, storage for five (5) years in tropical areas and hauling and handling during field erection etc. In the event that the drums are received at the destination in damaged condition thereby, preventing rolling out of cable, the Supplier shall supply extra drums at his own cost. Also, the cost incurred by the Purchaser in rewinding the cable from the damaged drums onto the new drums will be deducted from the amount due to the Supplier.

1.12.3 Internal and external surfaces of the drum shall be painted with bitumen based paint. A layer of waterproof material shall be provided on the barrel under the cable and on the inner surfaces of the flanges. Another layer of waterproof material shall be provided over the outer layer of cable under lagging.

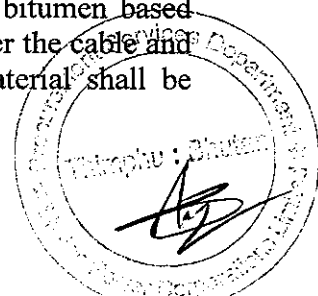

1.12.4 Drums shall be adequately protected by securely fastening substantial wooden battens around the periphery. These battens shall be secured by means of steel tap bindings.

1.12.5 Cables shall be securely fastened around the periphery of the drum. Cables shall be supplied with both ends properly capped, and protected against damage. Each drum and one of each cable length shall bear a metal label detailing manufacturer's name, specified voltage and type and length of conductor. The leading end of cable on cable drums shall be the 'A' end as defined in BS 6480.

1.12.6 The inner cable end attached to the drum shall be capped and sealed in such a manner that the core screening and sheath can be meggered from the outer cable end without removing the inner end cap.

1.13 Labels

1.13.1 All equipment shall be provided with labels or name plates, giving a description of the equipment, together with information regarding the rating, nominal voltage, nominal current and the like under which the item of plant in question has been designed to operate. The labels shall be provided on packaging to the Purchaser's approval.

1.13.2 Such nameplates or labels are to be of non-corrodible, non-hygroscopic material with lettering of a contrasting colour.

1.13.3 Labels on cable drums shall state the cable details, including the length in metres.

1.14 Locks

Provision shall be made for padlocking of mechanism boxes, isolators and outdoor switchgear as required by the Specification or as necessary to limit access or the safety of personnel. All padlocks will be provided by the Purchaser.

1.15 Supplier Documents and Drawings

1.15.1 General

The Supplier shall be responsible for submission, re-submission and obtaining approval as required of all the documents and drawings listed below (but not limited to), so that there shall be no delay to the work due to the absence of such documents and drawings. Any approval by the Purchaser will not relieve the Supplier of any obligations under the Contract.

Any alterations to the documents and drawings which may be required by the Purchaser for approval shall be made by the Supplier at his own expense. All materials and work involved in their manufacture shall be as indicated in such drawings.

No work shall be done on any part of the Goods, the design or construction of which is dependent on the approval of such drawings or data, until such approval has been given.

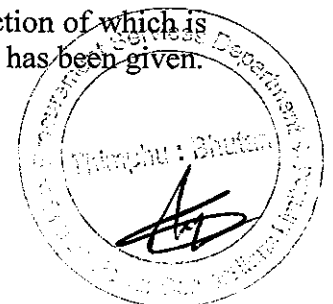

1.15.2 Manner of Submission and Approval of Drawings

The Supplier shall submit three prints of each drawing or document (including all the drawings, documents, calculations, manuals required under the Contract) for approval marked 'For Approval'. One copy will be returned to the Supplier marked up with approval or any proposed alterations or conditions. The Supplier shall provide the same number of further prints for any drawings that are altered. The submission of drawings for approval shall be repeated until 'Approved' or 'Approved with conditions' is given by the Purchaser.

Within fifteen working days after receipt by the Purchaser of any drawing or document requiring the Purchaser's approval, the Purchaser shall either return one copy thereof to the Supplier with its approval endorsed thereon or shall notify the Supplier in writing of its disapproval thereof and the reasons therefore and the modifications that the Purchaser proposes.

All drawings, information, design reports, etc shall be neatly type written and be presented as bound documents. The documents presented shall have neatly drawn title pages that clearly show the name of the Purchaser, identify the project name, the contract number, the date, the revision number, etc, and shall be provided with a table of contents.

Bidder need to submit 3 (three) hard copies of GTP's and drawing for approval after the award of contract.

1.15.3 Manuals

The Supplier shall submit the instruction manual for all the goods supplied under the contract. The Supplier shall follow the requirements as mentioned in the relevant clauses in the Technical Specifications.

1.16 Quality Assurance

1.16.1 The manufacturer must operate a quality assurance system that complies with ISO 9000. The Supplier shall provide current certification showing the manufacturers' compliance with ISO 9000 or equivalent national standard. The certificate must be issued by an independent, accredited issuing authority.

1.16.2 In compliance with the proposed quality assurance system of ISO 9000 or equivalent, Bidder shall submit with Bid the quality assurance plan for manufacturing the Goods. Especially, if the Bidder proposes to form a joint-venture or consortium, such a Bidder shall submit with Bid a quality assurance plan, including explanation how to manage the same quality of Goods by the joint-venture partners.

1.17 Tolerance

The variation in quantity to be supplied against confirmed order shall be permissible up to One (1) percent per item per consignee for delivery. However, for the short supply the payment shall be made as per the actual supply and for over supply the payment shall be limited to the ordered quantity.

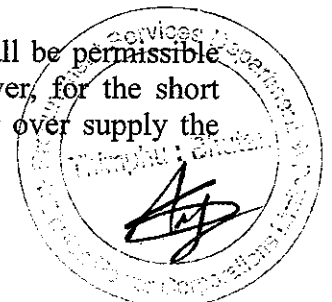

1.18 Inspection and Testing

The materials will be inspected at the Manufacturer's works by the Purchaser's representative. Tests shall be performed in accordance with the relevant IEC standards. In the absence of IEC recommendations the tests must be equivalent at least to the conditions, provisions and definitions of the above-mentioned standards. The supplier shall give at least one month's notice for readiness of equipment for testing at the manufacturer's works. The tests shall be divided into the categories described below.

1.18.1 Routine Tests

All the routine tests specified by the standards shall be carried out. If the tests are not witnessed by the Purchaser's representative, test certificates shall be submitted to the Purchaser for approval. Despatch clearance will be given only if the test results are approved.

1.18.2 Type Tests

Bidder shall include with his bid type test certificates, issued by an approved, reputed, independent testing laboratory. The type tests should have been carried out in the last five years.

In addition, the Purchaser may call for type tests to be carried out at the Manufacturer's Works and to be witnessed by the Purchaser or his representative. Such tests will be on random samples at the discretion of the Purchaser and failure to meet the conditions of test could result in the rejection of a complete batch of equipment. Type testing shall only be performed if the manufacturer is unable to provide type test certificates issued by an independent test laboratory of international repute.

Inspection

The Supplier shall intimate the Purchaser about the detailed program about the tests and inspection at least one month in advance.

Inspection and tests on all the Goods offered shall be carried out in the presence of Purchaser's representative unless inspection waiver has been given to the Supplier. The inspection shall be carried out as per the test procedure that has been approved by the Purchaser. The Supplier shall assist the work of the Purchaser's inspector by providing copies of all relevant Standards and test procedures, and allowing the inspector full use of the necessary tapes, measures and laboratory equipment, together with ample space and assistance in the handling of Goods for inspection.

The Supplier shall submit all final test and inspection reports to Purchaser's representative (inspector) during his stay at the workshop for the inspection. The inspector shall issue a "Dispatch Clearance" to the Supplier when the tests and inspection has successfully completed in compliance with the Technical Specifications.



1.19 Dispatch Clearance

- 1.19.1 The Supplier shall submit all final test and inspection reports to Purchaser's representative (inspector) during his stay at the workshop for the inspection. The inspector shall issue a "Dispatch Clearance" to the Supplier when the tests and inspection has successfully completed in compliance with the Technical Specifications.
- 1.19.2 The goods have to reach to the delivery warehouse within Twenty (20) days from the date of issuance of dispatch clearance (if the goods are supplied/manufactured from India & Nepal).
- 1.19.3 The goods have to reach to the delivery warehouse within Forty Five (45) days from the date of issuance of dispatch clearance (if the goods are supplied/manufactured from Third Countries).

Section – 2 Technical Requirements -Electrical

The following electrical technical requirements shall also apply to the equipment supplied under this Contract.

2.1 Electrical Supplies for Auxiliary Plant

The equipment provided under this Contract shall be capable of operating reliably at voltages down to 80% of the nominal voltage except where otherwise specified.

2.2 Electric Motors

- 2.2.1 All motors shall be in accordance with IEC 60034 and 60072 unless otherwise specified, shall be of the totally enclosed fan cooled type, suitable for continuous operation and direct on-line starting.
- 2.2.2 They shall be suitable in all respects for service in a damp tropical climate. Main conductor and slot insulation shall be non-hygroscopic and in accordance with Class F as per IEC 60085.
- 2.2.3 Motors to be located outdoor shall be entirely suitable for operation under the climatic conditions at site.
- 2.2.4 Motors shall be capable of operating continuously at rated output at any frequency between 48 and 51 Hz and at any voltage within ten percent of the nominal value. Motors shall be designed to be operated for a period of not less than five minutes at a voltage of 25% below the nominal value and at normal frequency without injurious overheating. If required by the purchaser, the supplier shall demonstrate that the motors comply with this requirement.
- 2.2.5 The starting current at full voltage shall not exceed six times the rated full load current.



- 2.2.6 All bearings shall be fitted with oil or grease lubricators. Vertical shaft motors shall have approved thrust bearings.
- 2.2.7 All terminals shall be of the stud type of adequate size for the particular duty, marked in accordance with an approved standard and enclosed in a weatherproof box.
- 2.2.8 All terminal boxes shall be fitted with an approved sealing chamber, conduit entry or adapter plate, as required, together with the necessary fittings to suit the type of cable specified.

2.3 Starters and Contactors

- 2.3.1 Where starters are to be provided under this Contract, each motor shall be equipped with two or three pole control gear as appropriate and suitable, unless otherwise specified, for direct starting by the switching of full line voltage on to a standing motor. All starters should preferably be supplied by one manufacturer.
- 2.3.2 Contactors are to be of robust design and are to comply with IEC 60947-4. They shall operate without undue noise or vibration.
- 2.3.3 Contactors shall be mounted in ventilated metal cubicles. Unless otherwise approved, the metal surface of the cubicle walls adjacent to the contactors shall be protected by fireproof insulating material. Where two or more contactors are contained in the same cubicle, they shall be separated by barriers of fireproof insulating material. The cubicles shall be complete with all locks, cable sealing boxes, busbars, internal wiring, terminal boards and accessories. All bare copper connections shall be taped and all secondary wiring is to be so arranged and protected as to prevent it being damaged due to arcing.
- 2.3.4 Starters shall be of the electrically held-in type with integral "start" and "stop" push buttons mounted externally on the door, with integral interlocked isolators. Where required, auxiliary switches shall be included for the operation of "red" and "green" indicating lights in remote instrument panels.
- 2.3.5 All motor contactors and their associated apparatus must be designed to operate for a period of not less than 5 minutes at a voltage of 25% below the nominal value and at normal frequency without injurious overheating.
- 2.3.6 For circuits controlling motors of 15 kW and above, transformer operated overload and phase failure relays shall be provided. For controlling motors of less than 15 kW, thermal overload trips shall be acceptable.

2.4 Cables, Cable Boxes, Sealing End Chambers and Glands

- 2.4.1 This Contract includes power, auxiliary power and multi-core control cabling as specified in the appropriate sections of the Specification. All cables where required shall be fitted with approved cable end boxes or glands, complete with all necessary fittings.



- 2.4.2 Air filled cable boxes shall be of adequate dimensions and designed in such a manner that they can be opened for inspection without disturbing the gland plate or incoming cable. Disconnecting chamber shall be provided for disconnecting and moving away the transformer without unscaling the cables leaving the cable box or chamber.
- 2.4.3 Phase to phase and phase to ground clearances shall be subject to purchaser's approval.
- 2.4.4 Provision shall be made for earthing the body of each cable box.
- 2.4.5 Corrosion protected brass material, compression type glands with armour and bonding clamps for the termination of all solid dielectric multi-core cables designed to secure the armour wires and to provide electrical continuity between the armour and the threaded fixing component of the gland and to provide watertight seals between the cable outer sheath and gland and between the inner sheath and threaded fixing component. The gland shall project above the gland plate to avoid ingress of condensed moisture.
- 2.4.6 All cable boxes shall have at least IP 54 degree of protection.

2.5 Electronic and Control Equipment

2.5.1 Component Ratings

Components and materials shall not be subjected to voltages; currents, temperature stresses, or any other condition outside the operational values given in the manufacturer's published data, over the range of temperature variations and climatic conditions indicated elsewhere.

Where circuits use components, which operate under unusual conditions, the Bidder shall produce documentary evidence that the life, stability and characteristics of the components used will be satisfactory.

Components which in their normal function may have full supply voltage applied shall be capable of withstanding continuous energisation.

2.5.2 Component Tolerances and Aging

The design of the circuits used shall be such that initial tolerances and also cyclic and non-cyclic changes in component values and parameters which may occur during the operational life of the equipment are either inconsequential or are compensated for.

Such compensation shall not necessitate the use of adjustable controls without the prior approval of the purchaser.

Standard components only shall be used and any individual selection necessary to obtain particular parameters shall be subject to the approval of the purchaser.

The combined effects of all tolerances, within a single component and between components, shall be allowed for by taking all tolerances in all worst case combinations produced by environmental and operating conditions. Other statistical assumptions that only certain combinations of tolerances will occur shall not be made unless the relevant parameters involved are invariably interdependent.

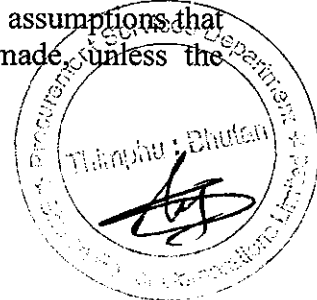

2.5.3 Protection

All circuits shall be protected so that in the event of a component fault, no damage occurs to any interconnecting wiring and any other damage that does occur is confined as closely as possible to the fault.

Protective devices shall be so arranged that the risk of fire within the equipment be minimised. The greatest possible protection shall be provided, consistent with reliability and the ability to withstand operational conditions.

Power supply units' with/without stabilisers shall be protected with voltage trip and overload current circuits with an auto recovery feature.

If any protective device, such as MCB, is incorporated in the output circuits of a current-limited power supply unit, the available current under short circuit conditions shall be sufficient to operate them. MCBs shall be in the 'non-common side of the circuit.

Indication of trip of MCBs shall be clearly displaced by monitoring of trip. Circuits shall be grouped so that, following the operation of a protective device, no false operation shall occur as a result of an MCB trips.

The design, location and connections of MCB shall be such that they do not present a danger to the operator when it is in service.

2.5.4 Interference

a) Self-generated Interference

Equipment shall not generate any type of interference at a level which could be detrimental to the performance of any other equipment or which could cause annoyance or discomfort to personnel. The earthing and cabling arrangements shall be such that detrimental interference is not generated.

b) External Interference

In the presence of interference expected in power station and substation environments, the design of the equipment shall be such that no damage occurs and performance is maintained to the requirements of the individual specifications.

c) Spark Quenching

Spark quenching devices shall be fitted wherever necessary to ensure continued satisfactory operation of contacts and prevent mal-operation of electronic devices.

d) Noise and Vibration

The acoustical noise levels and/or vibration produced by the equipment in operation shall be as low as is reasonably practicable for the type of equipment concerned and shall be agreed with the purchaser.

2.5.5 Setting-Up and Maintenance Facilities

All equipment shall be provided with sufficient easily accessible test points to facilitate setting-up and fault location together with maintenance aids such as extension boards, jumper leads and special maintenance tools.



Pin or terminal numbering of all cards in all crates shall be consistently uniform throughout. Power supplies shall use the same pin positions on all cards in an equipment or system.

2.5.6 Loose Equipment

Special connecting leads extension boards and any special item required for calibration or maintenance purposes, together with the mating half of all necessary connectors shall be supplied.

2.5.7 Printed Circuit Boards

Printed circuit boards shall be epoxy glass fabric boards to comply with IEC - 60321 suitable for use in hot humid climates. Printed circuit boards may be single-sided, double-sided or multi-layer.

Printed boards shall, in general, comply with IEC 60326. They shall not bow perceptibly when they are mounted in their shelves or racks. Means shall be provided to prevent boards being plugged into the wrong sockets and the plugging in/out action shall be arranged in a positive manner.

An approved protective coat shall be applied to the printed circuit side of the board to protect against tracking, tarnishing and general deterioration due to moisture and deposition of dust. The coating shall not have any adverse reaction with any other material or components used and shall be suitable for use under tropical conditions. When boards are repaired in the field it shall be possible to apply (or 'touch up') such a finish by simple convenient means.

2.5.8 Component Identification

- a. A component reference number shall be marked adjacent to each component. Where this is impossible, components shall be identifiable from the layout drawings provided.
- b. The following shall be marked in all instances:

MCBs

The rating and the circuit identification of each MCB shall be marked adjacent to the MCB base.

Control, Protection and Indication Devices

The function of each control, protection and indication device shall be marked. The caption and its arrangement shall be subject to the approval of the purchaser.

Preset Controls

The circuit reference and if possible, the function shall be marked adjacent to each preset control in a position where it will be clearly visible while the adjustment is being made.

Connectors

The diagram reference number shall be marked on or adjacent to each connector.

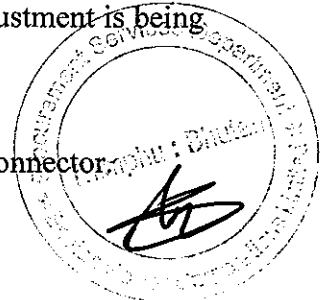

Test points shall be individually marked with the diagram reference number.

The polarity of any polarised devices (e.g. diodes) shall be marked.

Section – 3 Technical Requirements - Mechanical

The following mechanical general technical requirements shall apply to equipment supplied under this Contract.

3.1 Pipe Supports

- 3.1.1 The whole of the pipe work and accessories included in this Contract shall be supported and mounted in an approved manner. All necessary saddles, structural steelwork, foundation bolts, fixing bolts and all other attachments shall be supplied.
- 3.1.2 The number and positions of all intermediate flexible supports between anchor points shall be determined by the weights to be carried and by the steelwork available for the purpose and will be subject to the approval of the purchaser.

3.2 Valves

- 3.2.1 Valves shall be arranged so that the hand wheel moves in a clockwise direction to close the valve. The face of each hand wheel shall be clearly marked with the words “open” and “shut” and be provided with an arrow to indicate direction for opening and shutting. As far as possible valves shall not be fitted in an inverted position.
- 3.2.2 It shall be possible to remove and replace, or recondition in situ, the seats and to remove the gates. Valves of 50-mm nominal bore and above shall be provided with valve position indicators showing the amount by which the valve is open or closed in relation to its full travel.
- 3.2.3 All valve hand wheels shall be fitted with nameplates.
- 3.2.4 Suitable means shall be provided to protect the operating mechanisms of all valves against mechanical damage and dust or dirt. Adequate provision shall be made for the lubrication of the mechanism and guides and this shall preferably be of the pressure type.
- 3.2.5 Where it will be necessary to lock valves in the open or closed position, they shall be provided with a non-detachable locking arrangement.

3.3 Oil Level Indicators

- 3.3.1 Unless otherwise approved, oil level indicators of approved design shall be fitted to all oil containers other than hermetically sealed items.

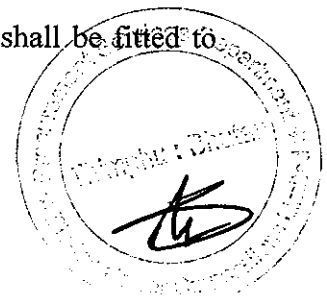

3.3.2 The indicators shall show the level at all temperatures 'likely to be experience in service, be marked with the normal level at 20°C clearly visible from normal access levels and be easily dismantled for cleaning.

3.4 Pressure Gauges

3.4.1 All pressure gauges shall be fitted with stopcocks immediately adjacent to each gauge and all pressure gauge piping shall be fitted with an isolating valve at each point of connection to the main system. Where pressure gauges are mounted on panels, the stopcocks shall be suitable for the connection of a test gauge.

3.4.2 Where a difference in level exists between the situation of the gauge and the point at which pressure is to be measured, appropriate compensation shall be made in the dial reading and the dial must be marked with the amount of compensation applied. Where the compensation would amount to two percent or less of the total movement indicated under normal conditions, it may be ignored.

3.4.3 All pressure gauges where practicable shall be mounted on panels in locations approved by the Purchaser. Stopcocks of gauges must be readily accessible. All pressure gauges shall be clearly identified by means of separate labels of approved type and lettering.

3.4.4 All high pressure gauge piping shall be of rustless steel but other pressure gauge piping may be of copper tube or other material approved by the purchaser.

3.5 Thermometer Pockets

3.5.1 Thermometer pockets and instruments connections of an approved pattern are to be fitted in such a position as may be determined to suit the operation and testing of the plant to the approval of the purchaser. Where necessary, the pocket shall be of approved material suitable for the required service.

3.5.2 All thermometer pockets shall comply with the requirements of BS 2765 or equivalent Indian standard.



2. Test Standards

1. Standards

The design material, construction, manufacture, inspection and testing of all equipment supplied under this Specification shall conform to the latest editions of the International Electro technical Commission (IEC) Specifications and other international standards where the material is not covered by IEC. Other national or international standards are accepted if they promise to confer equal or superior quality and performance than IEC or the specified standards.

2. Testing

The tests shall be divided into the categories described below.

2.1 Routine Tests

All the routine tests specified by the standards shall be carried out. If the tests are not witnessed by the Purchaser's representatives, test certificates shall be submitted to the Purchaser for approval. The test certificates must show the actual values obtained from the tests, in the units used in this Specification, and not merely confirm that the requirements have been met. No materials shall be dispatched until the test certificates have been received by the Purchaser and the Supplier has been informed that they are acceptable.

Despatch clearance will be given only if the test results are approved.

2.2 Type Tests

Bidder shall include with his bid type test certificates, issued by an approved, reputed, independent testing laboratory. The type tests should have been carried out in the last five years. Type tests shall be carried out at an independent testing laboratory or be witnessed by a representative of such laboratory or some other representative acceptable to the Purchaser. Type tests may be dispensed with at the Purchaser's discretion, if the Supplier furnishes evidence to the Purchaser's satisfaction, that the relevant tests have already been performed on identical materials and equipment.

In addition, the Purchaser may call for type tests to be carried out at the Manufacturer's Works and to be witnessed by the Purchaser or his representatives. Type testing shall only be performed if the manufacturer is unable to provide type test certificates issued by an independent test laboratory of international repute. Such tests will be on random samples at the discretion of the Purchaser and failure to meet the conditions of test could result in the rejection of a complete batch of equipment.

3. Inspection and Testing of Pole Fittings

The inspector shall examine the poles for, among other things, the following characteristics:

- general appearance;
- finish;



- dimensions; and
- straightness.

At least the following dimensional checks shall be made by the inspector:

- length;
- butt diameter and circumference;
- top diameter and circumference;
- non-circularity;
- accuracy of drillings;
- suitability of pole sections to overlap and bolt together;
- straightness, where appropriate;
- internal dimensions.

All cross-arms, clamps and fittings shall be examined by the inspector for, among other things, the following characteristics:

- general appearance;
- finish;
- dimensions;
- straightness;
- appropriate markings; and
- accuracy of drillings.

At least the following dimensional checks shall be made by the inspector:

- length;
- cross section of cross arm
- dimensions of clamp;
- position and size of holes;
- vertical alignment of all through holes.

The group of poles or fittings offered at any one time shall constitute a batch. Within a batch, poles and fittings presented for inspection shall be segregated on a size basis. If 5% of the inspected items show damage or serious deviations from the design criteria, the entire batch shall be unconditionally rejected without further sorting.

Dimensions, such as length and top diameter, shall be measured with a standard steel tape.

4. Inspection and Testing for Insulators

Insulators shall be tested in accordance to the requirements of the following standards in respect to type tests, unless certification is already available for the exact type being supplied, routine tests and sample tests.

- IEC Radio Interference characteristics of overhead
- IEC 60 High Voltage Test Techniques
- IEC 120 Dimensions of ball and socket coupling string insulators units
- IEC 305 Characteristics of string insulators of the cap and pin type
- IEC 372 Locking devices for ball and socket couplings of string insulator units: dimensions and tests

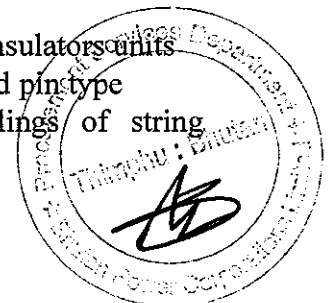

- IEC 383 Tests on insulators of ceramic materials and glass
- IEC 437 Radio interference test on high voltage insulators
- IEC 506 Switching impulse tests on high voltage insulators
- IEC 507 Artificial pollution tests on high voltage insulators to be used on A.C. systems
- IEC 575 Thermal - mechanical performance tests and mechanical performance test on string insulator units
- IEC 591 Sampling rules and acceptance criteria when applying statistical control methods for mechanical and electromechanical tests on insulators
- CISPR 18-2 Power lines and high voltage equipment
- IEC 797 Residual strength test
- ANSI C29.2 Impact strength test
- ASTM C151 Autoclave expansion of Portland Cement test
- BS 729 Hot dip galvanized coating on iron and steel articles
- BS 443 Specification for testing zinc coatings on steel wire for quality requirement.

Tests shall be carried out on random insulators taken from batches offered for inspection. The number of samples shall be selected as per IEC 383 with a minimum of five units. The samples shall be subjected to the following tests after having been subjected to routine tests in the same order:

- (a) Verification of dimensions
- (b) Temperature cycle test
- (c) Electro-mechanical or mechanical failing load test in accordance with the type of insulator, including thermal-mechanical performance test to IEC 575.
- (d) Puncture test
- (e) Porosity test
- (f) Galvanising test

In the event of one unit failing to pass any of the sample tests, a further quantity, double that of the first quantity shall be subject to retesting. In the event of two or more insulators or metal parts failing to pass any of the sample tests, or if any failure occurs on insulators or metal part subject to retesting, the complete batch will be rejected.

12.1 Type Tests

Bidders shall include with their offers type test certificates, including thermal, mechanical performance carried out in accordance with IEC575, which are issued by an approved, internationally acknowledged, reputed, independent testing laboratory. When type tests are called for by the Purchaser, they will comprise the following:

- 1.1 Dry lightning impulse withstand voltage test
- 1.2 Wet power frequency withstand voltage test



LOT 1& 2 (HV and LV ABC)**1.0 General****1.1 Scope of supply**

This section covers the requirements for the design, manufacture, testing, and delivery and unloading at BPC stores of ABC and AAAC conductors.

2.0 Standards

The items to be supplied under this section shall conform to the latest edition of AS: 3599.1-1988 (I &II) or equivalent international standards.

3.0 High Voltage Aerial Bundle Conductor

HV ABC consists of XLPE insulation. It has bearer wire (Messenger wire) which is either of aluminium alloy or steel wire (bare or insulated). The design of ABC shall comprise compacted, stranded, hard drawn aluminium phase conductors with dry cured cross linked polyethylene insulation. The main advantages of HV ABC over bare ACSR conductors are as follows:

- Offers relative resistance to short circuits caused by external forces (wind, fallen branches), unless they abrade the insulation.
- Can stand in close proximity to trees and branches will not generate sparks if in contact
- Simpler installation, as cross arms and insulators are not required.
- Less cluttered appearance than bare conductors.
- It can be installed in a narrower right-of-way.

However the disadvantages were additional cost for the cable itself and shorter spans and maximum use of poles due to increased weight of the cable. The Insulation of the cable also degrades due to direct exposure to sun. ***The Bidder shall submit the XLPE Insulation test results towards test being passed for UV Weathering test with the type test report.***

Following HV Aerial Bundled Cable conforming to AS: 3599.1-1988 (I &II) are used:

The Minimum Technical Requirement of the HV ABC

Characteristics	Unit	11kV	
Applicable Standards	AS: 3599.1-1988 (I & II), ASTM G154, ASTM G155		
Rated Voltage	kV	6.35/11(12)	
Conductor			
Nom. Area of core Conductor	mm ²	50	95
Conductor Screen Material	Extruded cross-linked semi-conductive		
Min. Thickness of Conductor Screen	mm	0.3	0.3
Insulation			
Insulation material	XLPE		
Min. Thickness of Insulation	mm	3.4	3.4
Min. Thickness of insulation Screen	mm	0.8	0.8

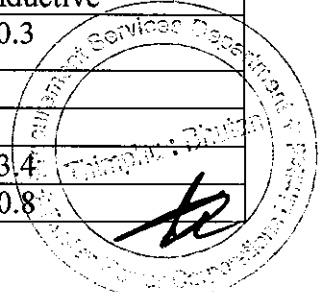

Metallic Screen			
Material	Plain Annealed Copper Wire		
Size for Conductor Screen ¹	No./mm	26/0.85	26/0.85
Sheath			
Material	Black, High Density Polyethylene (HDPE)		
Min. Thickness of sheath	mm	1.8	1.8
Support Catenary			
Support Catenary size	No./mm	19/2	19/2
Material	Aluminium-Clad Steel without insulation		
Max. D.C Resistance of cable at 20°C	Ohm/km	0.641	0.320
Max. A.C Resistance of cable at 90°C	Ohm/km	0.822	0.411
Inductive Reactance of cable at 50Hz	Ohm/km	0.144	0.134
Voltage drop (three phase)	mV/A.m	1.45	0.746
Max. continues current carrying capacity per phase	Amps	200	300
Approximate mass of cable	kg/km	2850	4090
Phase cable diameter (Nominal)	mm	25	29

The conductors shall be marked on the external surface with the following:

- Manufacturer's name
- Year of manufacture
- Length in meters marking in sequential numbers at 1 m intervals, with the lowest number at the inner end of the drum.
- Phase marking.

4.0 LV Aerial Bundled Conductor

4.1 General

The design of aerial bundled conductors shall comprise compacted, stranded, hard drawn aluminium phase conductors with dry cured cross linked polyethylene insulation, 0.6 to 1kV class, having not less than 2% of carbon black, similar to that specified in CENELEC Harmonisation Document 626. *The Bidder shall submit the XLPE Insulation test results towards test being passed for UV Weathering test with the type test report.*

All of the Aerial Bundled Conductors required shall be Fully Supported Cable, where all the equal-sized phase and neutral cores share the mechanical load. The cable shall be XLPE insulated and rated for 0.6/1kV. The bundle shall have a right-hand lay.

Two core cable shall be used for single phase distribution and 4 core cable for three phase. Typical design parameters for the ABC cable used are given in table below:

The Minimum Technical Requirement of the LV ABC

Cable Size (mm ²)	50		95		120
	2 core	4 core	2-core	4-core	4-core
Nominal conductor diameter (mm)	8.05		11.40		12.90
Minimum insulation thickness (mm)	1.5		1.7		1.7

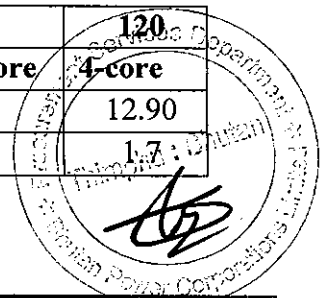

Section V- Schedule of Supply

Cable Size (mm ²)	50		95		120
	Nominal overall diameter (mm)	23.8	28.7	31.8	38.4
Approximate mass (kg/km)	350	700	680	1,350	1660
DC resistance at 20°C (ohms/km)	0.641		0.320		0.253
AC resistance at 50 Hz 80°C (ohms/km)	0.796		0.398		0.315
Inductive reactance at 50 Hz (ohms/km)	0.086	0.093	0.080	0.087	0.0844
Voltage drop at 50 Hz, 80°C (mV/A/m)	1.60	1.39	0.81	0.71	0.564
Continuous current rating in 1m/s wind (A)	150	140	230	215	280
Fault current rating (kA for 1 sec)	4.1		8.3		11.3
Minimum bending radius core (mm)	65		90		102
Minimum bending radius cable (mm)	130	160	270	320	352
Minimum breaking load (kN)	14.0	28.0	26.6	53.2	67.2
Recommended highest everyday tension (kN)	2.52	5.04	4.79	9.58	12.10
Recommended maximum working tension (kN)	3.92	7.84	7.45	14.90	18.82

The characteristics of the required Aerial Bundled Conductors are set out hereunder.

- a. Fully supported LV ABC 660/1100 Volt grade, 4 core, 120, 95 & 50 sq.mm XLPE insulation with Al conductor.
- b. Fully supported LV ABC 660/1100 Volt grade, 2 core, 95 & 50 sq.mm XLPE insulation with Al conductor.

4.2 Construction

The cores shall form a bundle, which comprise four (and two) single cores of insulated aluminium twisted together, for phase and neutral conductors. All conductors shall conform to IEC 1089 or equivalent international standards. The total pull of the line shall be distributed among the four (and two) conductors.

Each core shall be insulated with extruded cross linked polyethylene (XLPE) conforming to IEC 502 or equivalent international standards. The three phase conductors shall be indelibly marked with one, two or three, as appropriate or longitudinal ridges formed from the insulation material. The cores shall be twisted together with a right hand lay. The pitch of laying shall be such as to allow easy separation of conductors when making connection but also maintain the bundle cohesion at the angle points on the line route. The cable shall be rated for 600/1000V. Cables shall be supplied on drums, in one continuous length.

The conductors shall be marked on the external surface with the following:

- Manufacturer's name
- Year of manufacture
- Length in meters marking in sequential numbers at 1 m intervals, with the lowest number at the inner end of the drum.
- Phase marking.

The Bidder shall submit the UV weathering test for XLPE Insulation result with the bid.



Lot. 3 Technical Specifications of Telescopic Pole Fittings

Bolts, Nuts and Washers

All bolts, nuts and washers, supplied under this Specification shall comply with the following:

The bolts and nuts shall comply with ISO 4016. Mechanical properties shall be in accordance with ISO 898. The dimensions and characteristics in this Specification are intended to describe typical ISO metric bolts, nuts, and washers, such as are commonly used in the construction of electrical distribution lines, plant and equipment. The safe working shear stress of bolts is taken as 120 MPa, with the area of the bolt measured at the root of the thread. The table below shows the ultimate tensile strength, the tensile stress areas, the safe working tensile loads and the safe working shear loads for the bolts covered by this Specification. The ultimate shear strength has been assumed to be 75% of the ultimate tensile load and a factor of safety of 2.5 has been applied:

Bolt Size	Ultimate Tensile Stress (N/mm²)	Tensile Stress Area (mm²)	Ultimate Tensile Strength (kN)	Working Tensile Load (kN)	Safe Working Shear Load (kN)
M16	400	157.0	62	25	18
M18	400	204.0	81	32	24
M20	400	245.0	98	39	29

Screw threads shall be parallel throughout their length. They shall be so formed that, after galvanising, the nut can be easily screwed by hand over the whole length of thread, without excessive play. Before despatch from the works, one washer shall be fitted to each bolt and a nut shall be screwed on the whole threaded length and left in that position. Washers shall be round, flat, of mild steel, unless where otherwise specified.

Galvanising

Galvanising shall be in accordance with ISO 1459 and ISO 1461. The zinc coating shall not be less than 600 g/m² of steel surface area.

The zinc coating shall be smooth, continuous and uniform. It shall be free from acid spots and shall not scale, blister or be removable by handling or packing. There shall be no impurities in the zinc or additives to the smelter bath, which could have a deleterious effect on the durability of the zinc coating.

Before pickling, all welding, drilling, cutting, grinding must be completed and all grease, paint, varnish, oil and welding slag completely removed. All protuberances, which would affect the life of galvanising, should also be removed.

To avoid the danger of white rust, galvanised material shall be stacked during transport and stored in such a manner as to permit adequate ventilation.

Galvanised steel items shall be thoroughly checked for damage before transport to the work site.

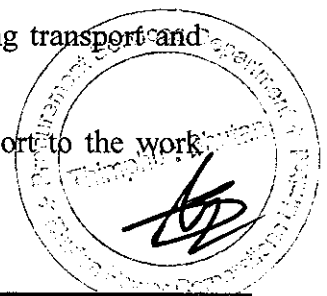

Any material found to be damaged shall be returned to its source. Cracked, flaked or scratched surfaces shall not be acceptable.

Galvanised steel shall be handled carefully during loading, transporting and unloading, and shall not be dropped on the ground, or dragged or scraped along the ground or any surface.

Painting

After manufacture, all items shall be painted for protection against corrosion.

The fittings shall be thoroughly cleaned by wire brush and the weld flux, if any, shall be removed. Phosphate treatment shall then be given, followed by light wiping by wet cloth. In accordance to the preparation of steel substrates before application of paints and related products ISO8502-4:1999

After drying, fittings shall be coated with bituminous preservative paint on the inside as well as on the outside surface over the length of pole, which is buried in the pole foundation; i.e. below ground. The ground line position shall be at approximately 1/6 of the total pole length.

The remaining exposed outside surface shall be painted with one coat of red oxide anti-rust primer with a dry film thickness of 40 Micrometers, prior to delivery, in accordance with ISO 12944-7 Paints and Varnishes - Corrosion protection of steel structures by protective paint systems - Part 7: Execution and supervision of paint work - ISO 12944-7:1998.

Identification Marks

The following identification marks shall be legibly engraved/ punched/ embossed on each pole at a height of 3m from bottom end of the pole, before painting:

1. Manufacturer's name/Trade mark
2. Year of manufacture
3. Batch Number

The size of the letters shall be at least 5mm and the depth of engraving/height of embossing shall be such that the text remains legible after painting.

Quality Control

All fittings shall be inspected by an inspector appointed by the Purchaser. The Supplier shall assist the work of the Purchaser's inspector by providing copies of all relevant Standards, and allowing the inspector full use of the necessary tapes, measures and laboratory equipment, together with ample space and assistance in the handling of poles for inspection. Any costs incurred by the Supplier in aiding the inspector shall be deemed to be included in the individual pole price.

Fittings as delivered to the designated stores shall be free of all damage to protective paint coating, and shall not be out of straight by more than one thousandth of the length of the pole.

Manufacturing of the materials shall be as per the samples provided by BPC. Samples shall be collected from Regional Store Division, Phuentsholing before fabrication.

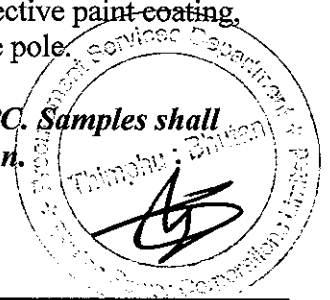

LOT 5: Insulators

1.0 General Specification

1.1 Scope

This Specification covers the design, manufacture, testing and inspection, packing, shipping, delivery, and performance requirements of Insulators.

Any departure from the provisions of this Specification shall be disclosed in the deviation sheet. This section covers the design, manufacture, testing, and delivery to site of porcelain insulators and fittings as follows:

- (i) Stay Insulator
- (ii) Polymer Disc Insulators and Fittings

2.0 Stay Insulators

Guy insulators shall conform to ANSI C29.4. The insulator shall be suitable for 7/8 SWG guy wire preformed terminations.

The common minimum characteristics shall apply to all guy insulators for both 11kV and 33kV distribution lines as shown below.

Minimum Characteristics of the stay/guy Insulators

Characteristics	Unit	33 kV & 11 kV	415/240 ¹
Minimum failing load	kN	88	44
Creepage Distance	mm	57	41
Dry one minute power frequency withstand voltage	kV(rms)	27	18
Wet one minute power frequency withstand voltage	kV(rms)	13	8
Length	mm	140	90
Diameter	mm	85	65
Cable hole dia	mm	25	16

3.0 Identification Marks

Each insulator unit shall be marked with the name or trade mark of the manufacturer and the year of manufacture in accordance with IEC 61109, and means to ensure a system of traceability for each of the component parts. In addition, each insulator unit shall be marked with the specified mechanical failing load in conformity with IEC 61109.

The design of identification marks on insulators shall be subject to approval by the Purchaser.

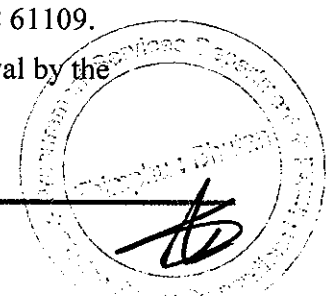

4.0 Polymer Disc Insulators

Composite strain insulators to IEC 61109 and IEC 60471 complete with ball and socket fittings conforming to IEC 60305 and IEC 60120 shall be supplied. The polymer strain insulators shall withstand the conductor tension, the reversible wind load as well as the high frequency vibrations due to wind.

The minimum characteristics of the polymer strain insulator shall be as per ANSI C29.1/29.5, IEC 61109 and shall be of the following.

Minimum Characteristics applied to Polymer Disc Insulators

Characteristics	Unit	11 kV	33 kV
Applicable Standard		IEC 61109-2008 and IS 731	
Type of insulators		Composite	
Material of the insulator		Silicon rubber	
Material of the core rod		ECR grade Boron free	
Material of the housing & weather sheds		Silicon Rubber	
Material of the end fittings		spheroidal graphite cast Iron (SGCI) with hot dip galvanised	
Sealing compound of the end fitting		Silicon based sealant	
Type of sheds		Aerodynamic with alternating sheds	
Diameter of FRP rod	mm	24	
Insulator Test Voltage			
Highest System Voltage	kV(RMS)	12	36
Visible Discharge Test	kV(RMS)	9	27
Wet-Power frequency withstand	kV(RMS)	28	70
Minimum power frequency flashover voltage			
• Dry	kV	110	140
• Wet		70	95
Power frequency puncture withstand test	kV	145	185
Impulse voltage withstand test	kV peak	75	170
Nominal creepage distance	mm	25mm/kV	25mm/kV
Mechanical Load			
Cantilever strength (Minimum failing load)	kN	70	70
Color	-	Grey	

The locking devices for the ball and socket couplings shall comply with IEC 60372 recommendations.

The clip shall be W-type and of phosphor bronze material. Retaining pins or locking devices for the insulator units shall be of phosphor bronze, supplied in the hard condition. The pins and locking devices shall be such that, when set under any condition of handling or service, nothing but extreme deformation shall allow separation of the insulator units or fittings or shall cause any risk of any retaining pins or locking devices being accidentally displaced.

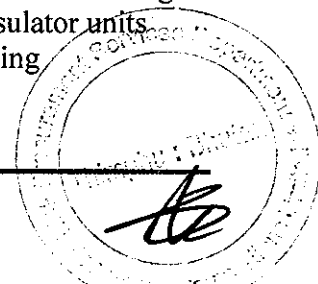

5.0 Fittings and Accessories for Polymer Disc Insulator

The Supplier shall be responsible for design and supply of a complete set of strain insulator assemblies (fittings and accessories) to suit for the coupling with the following parts:

- (i) Cross arm channel on double pole structure to be provided by another Supplier under Package 1
- (ii) Helical (preformed) dead end termination to be provided by another Supplier.

The supplier shall provide the strain insulator with complete set of assemblies, including a cross arm strap, a ball-eye, a socket-thimble, necessary GI bolts 175 mm long with half threaded and end locking clips, nuts, flat and spring washers.

The socket-thimbles shall be of aluminium alloy and suitable for range of size of preformed dead-end terminations. The socket-thimble shall be supplied with a hot-dip galvanised hexagon cross-section cotter pin fitted with a humpback stainless steel split pin. For coupling between the clevis-thimble and the ball of insulator, a socket-eye shall be provided.

Bidder is required to provide the assembly drawing(s) for strain insulator with the above assembly.

6.0 Insulator Components of Polymer Strain Insulators

Polymeric strain insulators shall be designed to meet the high quality, safety and reliability and are capable of withstanding a wide range of environmental conditions.

Polymeric Insulators shall consist of THREE parts, at least two of which are insulating parts:

- (a) Core- the internal insulating part
- (b) Housing- the external insulating part
- (c) Metal end fittings.

a) Core

It shall be a glass-fiber reinforced epoxy resin rod of high strength (FRP rod). Glass fibers and resin shall be optimized in the FRP rod. Glass fibers shall be Boron free electrically corrosion resistant (ECR) glass fiber or Boron free E-Glass and shall exhibit both high electrical integrity and high resistance to acid corrosion. The matrix of the FRP rod shall be Hydrolysis resistant. The FRP rod shall be manufactured through Pultrusion process. The FRP rod shall be void free.

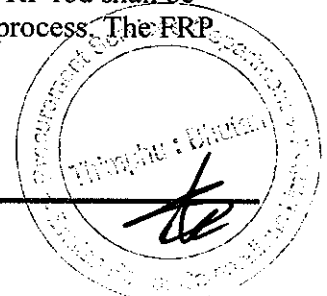

b) Housing

The FRP rod shall be covered by a seamless sheath of a silicone elastomeric compound or silicone alloy compound of a thickness of 3mm minimum. It shall be one-piece housing using Injection Molding Principle to cover the core. The elastomer housing shall be designed to provide the necessary creepage distance and protection against environmental influences. Housing shall conform to the requirements of IEC 61109/92-93 with latest amendments

c) Weathersheds

The composite polymer weather sheds made of a silicone elastomeric compound or silicone alloy compound shall be firmly bonded to the sheath, vulcanized to the sheath or molded as part of the sheath and shall be free from imperfections. It should protect the FRP rod against environmental influences, external pollution and humidity. The weather sheds should have silicon content of minimum 30% by weight. The strength of the weather shed to sheath interface shall be greater than the tearing strength of the polymer. The interface, if any, between sheds and sheath (housing) shall be free from voids.

d) Metal End Fittings

End fitting transmit the mechanical load to the core. They shall be made of spheroidal graphite cast iron, malleable cast iron or forged steel or aluminum alloy. They shall be connected to the rod by means of a controlled compression technique. Metal end fittings shall be suitable for tongue & clevis hard wares of respective specified mechanical load and shall be hot dip galvanized after, all fittings have been completed. The material used in fittings shall be corrosion resistant. As the main duty of the end fittings is the transfer of mechanical loads to the core the fittings should be properly attached to the core by a coaxial or hexagonal compression process & should not damage the individual fibers or crack the core. The gap between fitting and sheath shall be sealed by a flexible silicone elastomeric compound or silicone alloy compound sealant. System of attachment of end fitting to the rod shall provide superior sealing performance between housing, i.e. seamless sheath and metal connection. The sealing must be moisture proof. The dimensions of end fittings of Insulators shall be in accordance with the standard dimensions stated in IEC 60120.

The design of the insulators shall be such that stresses due to expansion and contraction in any part of the insulator shall not lead to deterioration. The core shall be sound and free of cracks and voids that may adversely affect the insulators.

Under-surfaces and grooves shall be shaped for easy cleaning. Shells shall be substantially symmetrical in shape without appreciable warping. The wire grooves of pin insulators shall be formed to provide a firm support for the conductor and shall permit the making of a secure tie.

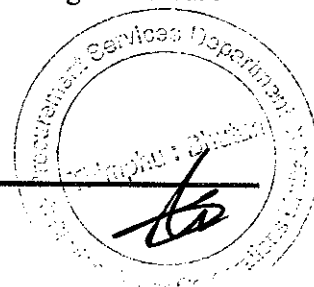

Section V- Schedule of Supply

Insulators shall be designed to avoid excessive concentration of electrical stresses in any section or across leakage surfaces. Design features which increase radio influence level shall be avoided.

All metal parts shall be made of good commercial grade malleable iron or open hearth or electric furnace steel, hot dip galvanised conforming to relevant standards.

7.0 Inspections and Tests

7.1 General

All tests shall be carried out in accordance with the relevant IEC Standards and other applicable Standards.

The cost for the tests shall be included in the prices estimated in the Price Schedules of Goods.

The Bidder shall submit type test reports with the bid. In case the type test reports submitted with Bid are of the tests conducted earlier than five years as on the date of bid opening, the Supplier shall repeat these type tests at no extra costs to the Purchaser.

7.2 Routine Tests

The following items shall be carried out according to the IEC standards:

- Visual examination
- Mechanical routine test
- Electrical routine test

7.3 Sample Tests

Insulators for the sample tests shall be selected at random from the batch. The number of test pieces shall be P, or the nearest whole number greater than P given by the following formulae.

P subject to agreement when $n < 500$

$P = 4 + (1.5 n / 1,000)$, when $500 < n < 20,000$

$P = 19 + (0.75 n / 1,000)$, when $n > 20,000$

where, n = number of insulators in the batch

After having withstood the routine test stated above, the test pieces of insulators shall be subject to the following tests.

- (i) Verification of dimensions
- (ii) Temperature cycle test

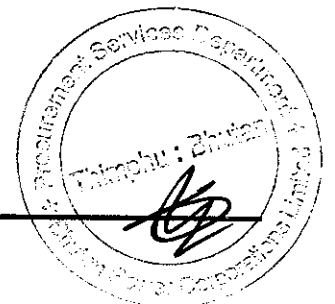

Section V- Schedule of Supply

- (iii) Electromechanical failing load test
- (iv) Puncture test
- (v) Porosity test
- (vi) Galvanizing test (mass of zinc per unit surface)

If only one insulator or metal part fails to comply with any of the sample test, a new quantity equal to twice the quantity originally subjected to that test shall be subject to re-testing.

If two or more insulators or metal parts fail to comply with any of the sample test, or if any failure occurs on insulators or metal parts subjected to re-testing, the complete batch will not be accepted.

7.4 Inspection by Purchaser

Inspection and tests on all the Goods offered shall be carried out in the presence of Purchaser's representative unless inspection waiver has been given to the Supplier. The inspection shall be carried out as per the test procedure that has been approved by the Purchaser. The Supplier shall assist the work of the Purchaser's inspector by providing copies of all relevant Standards and test procedures, and allowing the inspector full use of the necessary tapes, measures and laboratory equipment, together with ample space and assistance in the handling of Goods for inspection.

The Supplier shall submit all final test and inspection reports to Purchaser's representative (inspector) during his stay at the workshop for the inspection. The inspector shall issue a "Dispatch Clearance" to the Supplier when the tests and inspection has successfully completed in compliance with the Technical Specifications.



PART 3- Conditions of the Contract and Contract Forms

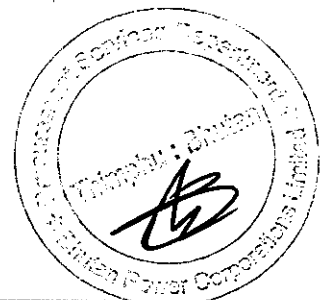

Section VI. General Conditions of Contract

Table of Contents

1.	Definitions.....	3
2.	Use of Contract Documents and Information	3
3.	Change Orders	4
4.	Contract Amendments	4
5.	Subcontracting	4
6.	Country of Origin.....	5
7.	Inspection and Tests.....	5
8.	Packing and Documents.....	5
9.	Delivery and Documents.....	6
10.	Indemnity against infringement of Intellectual Property Rights.....	6
11.	Performance Security.....	7
12.	Insurance	7
13.	Warranty	7
14.	Payment.....	8
15.	Contract Prices	8
16.	Contract Execution Schedule and Extensions in the Supplier's Performance	8
17.	Liquidated Damages	9
18.	Termination for Default	9
19.	Termination for insolvency.....	10
20.	Termination for Convenience	10
21.	Resolution of Disputes.....	10
22.	Applicable Law.....	10
23.	Force Majeure	11
24.	Assignment	11
25.	Contract Language.....	11
26.	Taxes and Duties.....	11
27.	Waiver.....	11
28.	Limitation of Liability.....	11
29.	Export Restriction	12

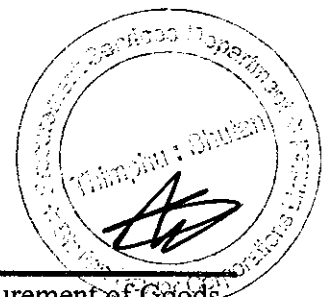

Section VI. General Conditions of Contract (GCC)

1. Definitions	
1.1	In this Contract, unless the contract otherwise requires, the term:
(a)	"The Contract" means any lawful agreement entered into between the Purchaser and the Supplier, as recorded in the Contract Agreement signed by the parties, including all attachments and appendices thereto and all documents incorporated by reference therein.
(b)	"Contract Documents" means the documents listed in the Agreement, including any amendments thereto.
(c)	"The Contract Price" means the price payable to the Supplier as specified in the Contract Agreement, subject to such additions and adjustments thereto or deductions there from as may be made pursuant to the Contract.
(d)	"The Goods" means all the equipment, machinery, and/or other materials, which the Supplier is required to supply to the Purchaser under the Contract.
(e)	"The Services" means those services ancillary to the supply of the Goods, such as transportation and Insurance, provision of technical assistance, training, and other such obligations of the Supplier covered under the Contract.
(f)	"The Purchaser" means the entity purchasing the Goods and Related Services, as specified in the SCC.
(h)	"The Supplier" means the individual or firm supplying the Goods and Services under the Contract.
(i)	"Day" means calendar day.
(j)	"Delivery" means the transfer of the Goods from the Supplier to the Purchaser in accordance with the terms and conditions set forth in the Contract Documents.
(k)	"SCC" means Special Conditions of Contract.
(l)	"Subcontractor" means any natural person, private or government entity, or a combination thereof, including its legal successors and permitted assigns, to whom any part of the Goods to be supplied or execution of any part of the Related Services is subcontracted by the Supplier.
(m)	"Incoterms" means a series of international sales terms, published by the International Chamber of Commerce (ICC) in Paris, France.
2. Use of Contract Documents and Information	
2.1	The Supplier shall not, without the Purchaser's prior written consent, disclose the Contract, or any provision thereof, or any specification, drawings, pattern, sample or information furnished by or on behalf of the Purchaser in connection therewith, to any person other than a person employed by the Supplier in the Performance of the Contract. Disclosure to any such employed person shall be made in confidence and shall extend only so far as may be necessary for purposes of such performance.

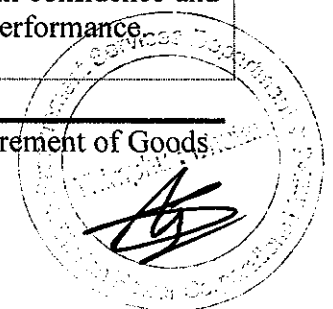

Section VIII- Contract Forms

2.2	The supplier shall not, without the Purchaser's prior written consent, make use of any document or information specified in GCC Clause 2.1 above, except for purposes of performing the Contract.
2.3	Any document, other than the Contract itself, specified in GCC Clause 2.1 above, shall remain the property of the Purchaser and shall be returned (in all copies) to the Purchaser, on completion of the Supplier's performance under the Contract, if so required by the Purchaser.
3. Change Orders	
3.1	The Purchaser may at any time, by a written notice to the Supplier, make changes within the general scope of the Contract in any one or more of the following:
	(a) Decrease or increase in quantity within the delivery period.
	(b) Drawings, designs or specifications, where Goods to be furnished under the Contract are to be specifically manufactured for the Purchaser; or
	(c) The method of shipment or packing; or
	(d) The place of delivery.
	(e) The Related Services to be provided by the Supplier.
3.2	If any such change causes an increase or decreases in the cost of, or the time required for, the Supplier's performance of any provisions under the Contract, an equitable adjustment shall be made in the Contract Price or in the Delivery/Completion Schedule, or both, and the Contract shall accordingly be amended. Any claims by the Supplier for adjustment under this Clause must be asserted within Twenty-eight (28) days from date of the Supplier's receipt of the Purchaser's change order.
3.3	Prices to be charged by the Supplier for any Related Services that might be needed but which were not included in the Contract shall be agreed upon in advance by the parties and shall not exceed the prevailing rates charged to other parties by the Supplier for similar services.
3.4	The Supplier shall not perform changes in accordance with GCC Clause 3.1 above until the Purchaser has authorized a change order in writing on the basis of the estimate provided by the Supplier as described in GCC Clause 3.2 above.
3.5	Changes mutually agreed upon as a Change shall constitute a part of the work under this Contract, and the provisions and conditions of the Contract shall apply to the said change.
4. Contract Amendments	
4.1	Subject to Clause 3, no variation in or modification of the contract shall be made except by written amendment agreed and signed by the parties.
5. Subcontracting	
5.1	The Supplier shall not subcontract all or any part of the Contract without first obtaining the Purchaser's approval in writing of the subcontracting.
5.2	The supplier guarantees that any and all subcontractors of the Supplier to performance of any part of the work under the Contract will comply fully with the terms of the Contract applicable to such part of the work under the Contract and shall not relieve the Supplier of any of its obligations, duties, responsibilities or liabilities under the Contract.

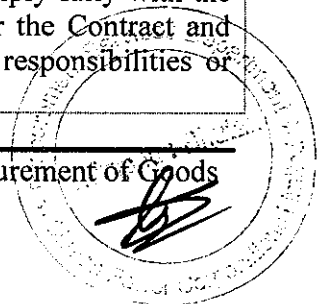

6. Country of Origin	
6.1	All Goods supplied under the Contract shall have their origin in eligible countries if these eligible countries are specified in the Special Conditions of Contract. For purposes of this Clause, "origin" shall be considered to be the place where the Goods were mined, grown or produced. Goods are produced when, through manufacturing, processing or substantial and major assembling of components, a commercially recognized new product results that is substantially different in basic characteristics or in purpose or utility form its components.
7. Inspection and Tests	
7.1	The Purchaser or its representative shall have the right to inspect and /or to test the Goods to confirm their conformity to the Specifications. At its own expense and at no cost to the Purchaser, the Supplier shall carry out all such tests and/or inspections of the Goods and Related Services as specified in Section V, Schedule of Supply. The Purchaser shall notify the Supplier in writing of the identity of representatives nominated for these purposes.
7.2	The inspections and tests may be conducted on the premises of the Supplier or its subcontractor(s), at point of delivery, and/or at the Goods' final destination, or in an another place in Bhutan as specified in SCC. Where conducted on the premises of the Supplier or its subcontractor(s), all reasonable facilities and assistance, including access to drawings and production data, shall be furnished to the inspectors at no charge to the Purchaser. The supplier shall also furnish copies of relevant reference IS documents or other relevant standards and test certificates for electrical equipment if specified in Section V, Schedule of Supply.
7.3	As specified in SCC, whenever the Supplier is ready to carry out any such test and inspection, it shall give reasonable advance notice, including the place and time, to the Purchaser. The Supplier shall obtain from any relevant third party or manufacturer any necessary permission or consent to enable the Purchaser or it's designated representative to attend the test and/or inspection.
7.4	The Purchaser shall reject any Goods or any part thereof that fail to conform to the Specifications. The Supplier shall either rectify or replace such rejected Goods or parts thereof or make all alterations necessary to meet the Specifications at no cost to the Purchaser, and shall repeat the test and/or inspection, at no cost to the Purchaser, upon giving a notice pursuant to Clause 7.3 above.
7.5	The Purchaser's right to inspect, test and, where necessary, reject the Goods after the Goods' arrival in the Bhutan shall in no way be limited or waived by reason of the Goods' having previously been inspected, tested and passed by the Purchaser or its representatives prior to the Goods' shipment from the country of origin.
7.6	The Supplier shall ensure that all the materials are ready during the time of inspection. In case the materials are to be re-inspected due to reasons which are attributable to the supplier, the same shall be done at the cost of the supplier.
7.7	Nothing in this Clause 7 shall in any way release the Supplier from any Warranty or other obligations under the Contract.
8. Packing and Documents	
8.1	The Supplier shall provide such packing of the Goods as is required to prevent their damage or deterioration during transit to their final destination, as per the Contract. The packing shall be sufficient to withstand, without limitation, rough handling

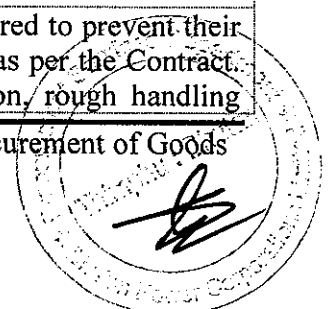

Section VIII- Contract Forms

	during transit and exposure to extreme temperatures, salt and precipitation during transit, and open storage. Packing case size and weights shall take into consideration, where appropriate, the remoteness of the Goods' final destination and the absence of heavy handling facilities at all points in transit.
8.2	The packing, marking, and documentation within and outside the packages shall comply strictly with such special requirements as shall be expressly provided for in the Contract, including additional requirements, if any, specified in Section V, Schedule of Supply and in any subsequent instructions ordered by the Purchaser.
9. Delivery and Documents	
9.1	Delivery of the Goods shall be made by the Supplier in accordance with the Section V, Schedule of Supply. The details of shipping and/or other documents to be furnished by the Supplier are specified in the SCC.
9.2	Unless inconsistent with any provision of the Contract or otherwise specified in the SCC, the meaning of any trade term and the rights and obligations of parties there under shall be as prescribed by Incoterms.
9.3	The terms EXW,CIP, CIF, DDP, and other trade terms used to describe the obligations of the parties shall be governed by the rules prescribed in the current edition of Incoterms specified in the SCC and published by the International Chamber of Commerce, Paris..
10. Indemnity against infringement of Intellectual Property Rights	
10.1	The Supplier shall, subject to the Purchaser's compliance with GCC Sub-Clause 10.2, indemnify and hold harmless the Purchaser and its employee(s) or representative(s) from and against any and all suits, actions or administrative proceedings, claims, demands, losses, damages, costs and expenses of any nature, including attorney's fees and expenses, which the Purchaser may suffer as a result of any infringement or alleged infringement of any patent, utility model, registered design, trademark, copyright or other intellectual property right registered or otherwise existing at the date of the Contract by reason of:
	(a) The installation of the Goods by the Supplier or the use of the Goods in Bhutan; and
	(b) The sale in any country of the products produced by the Goods.
	Such indemnity shall not cover any use of the Goods or any part thereof other than for the purpose indicated by or reasonably to be inferred from the Contract, neither any infringement resulting from the use of the Goods or any part thereof, or any products produced thereby in association or combination with any other equipment, plant or materials not supplied by the Supplier, pursuant to the Contract.
10.2	If any proceedings are brought or any claim is made against the Purchaser arising out of the matters referred to in GCC Sub-Clause 10.1, the Purchaser shall promptly give the Supplier notice thereof, and the Supplier may at its own expense conduct such proceedings or claim and any negotiations for the settlement of any such proceedings or claim.
10.3	The Purchaser may, at the Supplier's request, afford all available assistance to the Supplier in conducting such proceedings or claim, and shall be reimbursed by the Supplier for all reasonable expenses incurred in so doing.
10.4	The Purchaser shall indemnify and hold harmless the Supplier and its employees, officers and Subcontractors from and against any and all suits, actions or

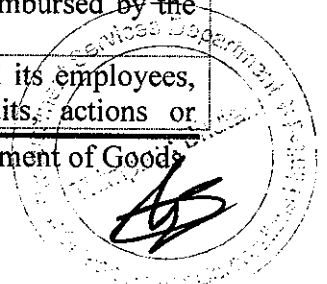

Section VIII- Contract Forms

	administrative proceedings, claims, demands, losses, damages, costs and expenses of any nature, including attorney's fees and expenses, which the Supplier may suffer as a result of any infringement or alleged infringement of any patent, utility model, registered design, trademark, copyright or other intellectual property right registered or otherwise existing at the date of the Contract arising out of or in connection with any design, data, drawing, specification or other documents or materials provided or designed by or on behalf of the Purchaser.
11. Performance Security	
11.1	The Supplier shall within fifteen (15) working days of notification of contract award , provide Performance Security in the amount and currency specified in the SCC.
11.2	The proceeds of the Performance Security shall be payable to the Purchaser as compensation from the Supplier's failure to complete its obligations under the Contract. The Performance Security is a security taken by the purchaser for due performance of the Contract and shall be forfeited if the Supplier fails without any legal excuse, to perform any promises that form the whole or part of a Contract or any agreement without need of establishing any loss incurred by the Purchaser. The Supplier shall cause the validity period of the Performance Security to be extended for such period(s) as the contract performance may be extended pursuant to GCC Clause 16.2.
11.3	The Performance Security shall be denominated in a currency (ies) of the Contract, or in a freely convertible currency acceptable to the Purchaser and shall be in one of the following forms:
	(a) Unconditional bank guarantee issued by a reputable financial institution acceptable to the Purchaser, in the form provided for in the Contract or in any other form acceptable to the Purchaser; or
	(b) Banker's Cheque/Cash Warrant; or
	(c) Demand Draft.
11.4	If the institution issuing the Performance Security furnished by the Bidder is located outside the Purchaser's country, the Performance Security shall be counter guaranteed by a correspondent financial institutions located in the Purchaser's country to make it enforceable.
11.5	The Performance Security shall be discharged by the Purchaser and returned to the Supplier not later than thirty (30) days following the date of completion of the Supplier's performance obligations or any pending contractual issues arising under the Contract, or any warranty obligations, unless specified otherwise in the SCC.
12. Insurance	
12.1	All Goods supplied under the Contract shall be fully insured in the currency of Contract against loss or damage incidental to manufacture or acquisition, transportation, storage and delivery, in accordance with the applicable Incoterms or in the manner specified in the SCC.
13. Warranty	
13.1	The Supplier warrants to the Purchaser that the Goods supplied under the Contract will comply strictly with Contract and shall be free from defects arising from any act

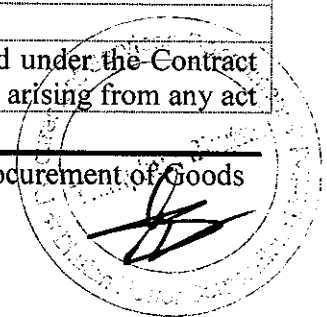

Section VIII- Contract Forms

	or omission of the Supplier or arising from design, materials, and workmanship under normal use in the conditions prevailing in the country of final destinations.
13.2	Unless otherwise specified in the SCC, the warranty shall remain valid for twelve (12) months after the Goods, or any portion thereof, as the case may be, have been delivered to and accepted at the final destination indicated in SCC.
13.3	The Purchaser shall notify the Supplier in writing stating the nature of any such defects together with all available evidence thereof, promptly following the discovery thereof. The Purchaser shall afford all reasonable opportunity for the Supplier to inspect such defects.
13.4	Upon receipt of such notice, the Supplier shall, within the period specified in the SCC repair or replace the defective Goods or parts thereof, at no cost to the Purchaser.
13.5	If the Supplier, having been notified, fails to remedy the defect(s) within the period specified in SCC, the Purchaser may proceed to take within a reasonable period such remedial action as may be necessary, at the Supplier's risk and expense and without prejudice to any other rights or remedies, which the Purchaser may have against the Supplier under the Contract.
14. Payment	
14.1	The method and conditions of payment to be made to the Supplier under the Contract shall be as specified in the SCC.
14.2	The Supplier's request(s) for payment shall be made to the Purchaser in writing accompanied by an invoice describing, as appropriate, the Goods delivered and services performed, and by documents submitted pursuant to GCC Clause 9 and upon fulfilment of other obligations stipulated in the Contract.
14.3	Payment shall be made by the Purchaser, but in no case later than 30 (thirty) days after submission of invoice or request for payment by the Supplier and the Purchaser has accepted it.
14.4	The currency or currencies in which payment is made to the Supplier under the Contract will be made in the currency or currencies specified in SCC.
15. Contract Prices	
15.1	The Contract Price shall be as specified in the Contract Agreement subject to any additions and adjustments thereto or deductions there from as may be made pursuant to the Contract.
15.2	Prices charged by the Supplier for Goods delivered and Services performed under the Contract shall not vary from the prices quoted by the Supplier in its bid, which the exception of any change in price resulting from a Change Order issued in accordance with GCC Clause 3, or if applicable, adjustments authorized in accordance with the price adjustment provisions specified in the SCC.
16. Contract Execution Schedule and Extensions in the Supplier's Performance	
16.1	Delivery of the Goods shall be made by the Supplier in accordance with the Contract Execution Schedule, pursuant to SCC.
16.2	The Supplier may claim extension of the time limits as set forth in the Contract Execution Schedule in case of:
(a)	Change in the Goods ordered by the Purchaser pursuant to GCC Clause 3;

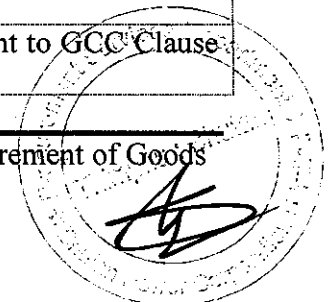

Section VIII- Contract Forms

	(b)	Delay of any materials, drawings or services, which are to be provided by the Purchaser; services provided by the Purchaser shall be interpreted to include all approvals by the Purchaser under the Contract;
	(c)	Force Majeure pursuant to GCC Clause 23; and
	(d)	Delay in performance of work caused by change order or amendment(s) issued by the Purchaser.
16.3		The Supplier shall demonstrate to the Purchaser's satisfaction that it has used its best endeavours or overcome such causes for delay, and the parties will mutually agree upon remedies to mitigate or overcome such causes for delay.
16.4		Notwithstanding GCC Clause 16.2 above, the Supplier shall not be entitled to an extension of time for completion unless the Supplier, at the time of such circumstances arising, has notified the Purchaser in writing within 10 (Ten) days of any delay that it may claim as caused by circumstances pursuant to GCC Clause 16.2 above; and upon request of the Purchaser, the Supplier shall substantiate that the delay is due to the circumstances referred to by the Supplier.
17. Liquidated Damages		
17.1		Subject to GCC Clause 16, if the Supplier fails to deliver any or all of the Goods or to perform the Services within the period(s) specified in the Contract, the Purchaser may without prejudice to its other remedies under the Contract, deduct from the Contract Price, as liquidated damages, a sum equivalent to the percentage specified in the SCC of the delivered price of the delayed goods or unperformed services for each week or part thereof of delay until actual delivery or performance, up to a maximum deduction of the percentage specified in the SCC. Once the maximum is reached, the Purchaser may consider termination of the Contract pursuant to GCC Clause 18, Termination for Default.
18. Termination for Default		
18.1		The Purchaser may, without prejudice to any other remedy for breach of Contract, by written notice of default sent to the Supplier, terminate the Contract in whole or in part:
	(a)	If the Supplier fails to deliver any or all of the Goods within the Contract delivery period(s) specified in the Contract, or any extension thereof granted by the Purchaser, pursuant to GCC Clause 16 without the need of waiting maximum deduction of percentage specified in GCC Clause 17.1 after serving 10 (ten) days notice in writing; or
	(b)	If the Supplier, in either of the above circumstances, does not cure its failure within a period of 10 (ten) days (or such longer period as the Purchaser may authorize in writing) after receipt of a notice of default from the Purchaser specifying the nature of the default(s); and
	(c)	If the supplier fails to perform any other obligation(s) under the Contract.
18.2		Subject to Clause 18.1 above, when the Contract is terminated for default, the Purchaser shall forfeit the Performance Security and deduct from the contract price, as liquidated damages, a sum equivalent to the percentage specified in the SCC of the delayed delivered price of the goods accepted by the Purchaser.



19. Termination for insolvency	
19.1	The Purchaser may at any time terminate the Contract by giving written notice to the Supplier, without compensation to the Supplier, if the Supplier becomes bankrupt or otherwise insolvent. Notwithstanding the above, such termination will not prejudice or affect any right of action or remedy, which has accrued or will accrue thereafter to the Purchaser.
20. Termination for Convenience	
20.1	The Purchaser may, by written notice sent to the Supplier, terminate the Contract, in whole or in part, at any time for its convenience. The notice of termination shall specify that termination is for the Purchaser's convenience, the extent to which performance of work under the Contract is terminated, and the date upon which such termination becomes effective.
20.2	The Goods that are complete and ready for shipment within 30 (thirty) days after the Supplier's receipt of notice of termination shall be purchased by the Purchaser at the Contract prices and on the other Contract terms. For the remaining Goods, the Purchaser may elect:
	(a) To have any portion thereof completed and delivered at the contract prices and as per the Contract terms; and/or
	(b) To cancel the remainder and pay to the Supplier an agreed amount for partially completed Goods and for materials and part previously procured by the Supplier.
21. Resolution of Disputes	
21.1	The Purchaser and the Supplier shall make every effort to resolve amicably by direct informal negotiation any disagreement or dispute arising between them under or in connection with the Contract.
21.2	If, after 30 (thirty) days from the commencement of such informal negotiations, the Purchaser and the Supplier have been unable to resolve amicably a Contract dispute, either party may require that the dispute be referred for resolution by arbitration as described in Clause 21.3.
21.3	If the dispute is to be settled by arbitration, the Purchaser and the Supplier shall be entitled to appoint one member each, and third arbitrator will be appointed by both of them by mutual consent. If either the Purchaser or the Supplier fails to appoint a representative, or both of them cannot agree on the appointment of a third member within thirty (30) days from the date of agreement to refer the matter for arbitration, then the case will be referred to the proper court in Bhutan for adjudication. The award shall be final and binding on the parties if not appealed within 10 (Ten) working days. If the disputes are settled by Arbitration, the cost of Arbitration shall be borne by both parties equally.
21.4	The arbitrations proceedings shall be conducted in accordance with the rules of procedures specified in SCC.
22. Applicable Law	
22.1	The Contract shall be governed by and interpreted in accordance with the laws of the Bhutan.



23. Force Majeure	
23.1	The Supplier shall not be liable for forfeiture of its Performance Security, liquidated damages or termination for default if and to the extent that its delay in performance or other failure to perform its obligations under the Contract is the result of an event of Force Majeure. Such delay may be excused as provided in GCC Clause 16, and the period of such delay may be added to the time of performance of the obligation delayed.
23.2	For purposes of this Clause, "Force Majeure" means an event or situation beyond the control of the Supplier that is not foreseeable, unavoidable, and its origin is not due to negligence or lack of care or other malfeasance on the part of the Supplier. Such events may include, but not be limited to, acts of the Purchaser in its sovereign capacity, wars or revolutions, fires, floods, epidemics, quarantine restrictions, strikes, riot, and freight embargoes.
23.2	If a Force Majeure situation arises, the Supplier shall notify the Purchaser in writing of such condition and the cause thereof within 10 (ten) days. Unless otherwise directed by the Purchaser in writing, the Supplier shall continue to perform its obligations under the Contract as far as is reasonably practical, and shall seek all reasonable alternative means for performance not prevented by the Force Majeure event.
24. Assignment	
24.1	The Supplier shall not assign, in whole or in part, its obligations to perform under the Contract, except with the Purchaser's prior written consent.
25. Contract Language	
25.1	The Contract, as well as all correspondence and documents relating to the Contract exchanged by the Supplier and the Purchaser, shall be written in the language specified in the SCC. Supporting documents and printed literature that are part of the Contract may be in another language provided they are accompanied by an accurate translation of the relevant passages in the language specified in the SCC, in which case, for purposes of interpretation of the Contract, the translation shall govern.
25.2	The Supplier shall bear all costs of translation to the governing language and all risks of the accuracy of such translation, for documents provided by the Supplier.
26. Taxes and Duties	
26.1	The Supplier shall bear and pay all applicable taxes, stamp duties, license fees and other similar levies imposed both outside and inside Bhutan, as specified in SCC.
27. Waiver	
28.1	Failure of either party to insist upon strict performance by the other party of any provision of the Contract shall in no way be deemed or construed to effect in any way the right of that party to require such performance.
28. Limitation of Liability	
29.1	Except in cases of gross negligence or wilful misconduct:
(a)	Neither party shall be liable to the other party, whether in contract, tort or otherwise, for any indirect or consequential loss or damage, loss of use, loss of production, or loss of profits or interest costs, provided that this exclusion shall not apply to any obligation of the

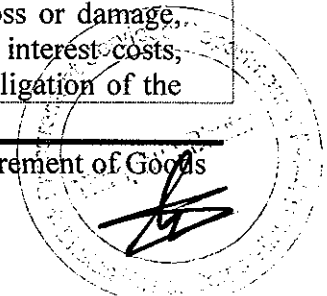

Section VIII- Contract Forms

		Supplier to pay liquidated damages to the Purchaser; and
	(b)	The aggregate liability of the Supplier to the Purchaser, whether under the Contract, in tort or otherwise, shall not exceed the total Contract Price, provided that this limitation shall not apply to the cost of repairing or replacing defective equipment, or to any obligation of the Supplier to indemnify the Purchaser with respect to patent infringement.
29. Export Restriction		
31.1		Notwithstanding any obligation under the Contract to complete all export formalities, any export restrictions attributable to the Purchaser, to Bhutan, or to the use of the products/Goods, systems or services to be supplied, which arise from trade regulations from a country supplying those products/Goods, systems or services, and which substantially impede the Supplier from meeting its obligations under the Contract, shall release the Supplier from the obligation to provide deliveries or services, always provided, however, that the Supplier can demonstrate to the satisfaction of the Purchaser that it has completed all formalities in a timely manner, including applying for permits, authorizations and licenses necessary for the export of the products/Goods, systems or services under the terms of the Contract. Termination of the Contract on this basis shall be for the Purchaser's convenience pursuant to Clause 20.

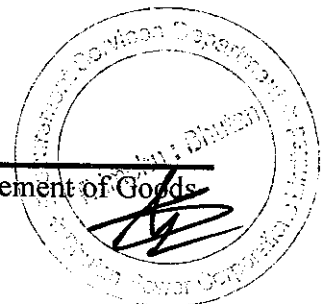

Section VII. Special Conditions of Contract

Table of Contents

1.	Definitions.....	2
2.	Inspection and Test.....	2
3.	Packing and Documents.....	2
4.	Delivery and Documents.....	3
5.	Performance Security.....	3
6.	Insurance.....	4
7.	Warranty.....	4
8.	Payment.....	4
9.	Contract Prices.....	5
10.	Contract Execution Schedule and Extension in the Supplier's Performance.....	5
11.	Liquidated Damages.....	5
12.	Resolution of Disputes.....	5
13.	Taxes and Duties.....	6



Section VII. Special Conditions of Contract (SCC)

The following Special Conditions of Contract (SCC) shall supplement the General Conditions of Contract (GCC). Whenever there is a conflict, the provisions herein shall prevail over those in the General Conditions of Contract (GCC).

1. Definitions

GCC 1.1 (f) The Purchaser is: *Procurement Services Department, Bhutan Power Corporation Limited, Yarden Lam, Post Box No. 580, Thimphu, Bhutan.*

The consignee is:
The Chief Manager, Regional Store Division, Regional Stores Division, Bhutan Power Corporation, Phuentsholing, Bhutan.

2. Inspection and Test

GCC 7.1 The inspections and tests shall be: *Applicable*

GCC 7.2 Inspections and tests shall be conducted at: *Manufacturer's premises.*

GCC 7.3 All materials shall be inspected and tested as specified in the relevant IEC or BS or IS standards. The supplier must notify the purchaser in writing by mailed copy within twenty (20) days in advance once the goods are ready for dispatch. This should be notified to purchaser at the following address:

Attention: *The General Manager*

Address: *Procurement Services Department
Bhutan Power Corporation Limited
Thimphu: Bhutan*

Telephone: *00975-2-336046/325095, Extn: 449*

E-mail address: *psdbpc@gmail.com & alkapradhan@bpc.bt*

The period indicated is for deputing an inspector and has no connection with the stipulated delivery schedule. If the delay in the delivery of all or part of materials has been caused due to delay in nominating inspectors by the purchaser after the inspection call has been received in writing by the purchaser, the delivery period shall be extended by the period equivalent to the delay in sending inspectors by the purchaser for the whole or part of the materials.

GCC 7.5 To ensure that the goods are delivered in good condition, suppliers/supplier's representatives need to be present for the joint inspection of the goods at the BPC warehouse and sign the joint inspection report.

3. Packing and Documents

GCC 8.2 The supplier shall pack all the Goods as is required to prevent damage or deterioration in transit to the final destination. The packing should be sufficient to withstand rough handling and exposure to extreme temperatures, salt and precipitation during transit and/or storage as per GCC Clause 8.

4. Delivery and Documents

GCC 9.1 a. The good need to be delivered at the designated place as specified in Section V, Schedule of Supply. Further, the shipment should be completed within 21 (twenty one) days after inspection/dispatch clearance if the delivery is made from India and within 60 (sixty) days if the delivery is made from Third countries. However, the overall schedule for delivery of the material at the place



Section VIII- Contract Forms

	<p>of delivery as per contract stipulations shall be met and any delay in meeting the schedule will be dealt with as per contract stipulation including but not limited to Liquidated Damages.</p> <p>b. Details of Shipping and other Documents to be furnished by the Supplier after the delivery of goods are:</p> <p>(i) Copies of the Supplier's invoice showing Goods description, quantity, unit price, and total amount;</p> <p>(ii) Suppliers Good Issues Note (Challan);</p> <p>(iii) Copy of import declaration form (B-Form) in Bhutan;</p> <p>(iv) Original tax paid receipt in Bhutan.</p> <p>(v) Manufacturer's or Supplier's warranty certificate;</p> <p>(vi) Packing List;</p> <p>(vii) Inspection report/Test Certificate;</p>
GCC 9.2	The meaning of the trade terms shall be as prescribed by Incoterms 2010, read in conjunction with any specific explanation of the tender.
GCC 9.3	The version of Incoterms shall be: 2010, read in conjunction with any specific explanation of the tender.
5. Performance Security	
GCC 11.1	The amount of Performance Security shall be: 10% of the contract value.
GCC 11.5	Discharge of Performance Security shall take place: As indicated in GCC Sub-Clause 11.5
6. Insurance	
GCC 12.1	The insurance coverage shall be as specified in the Incoterms 2010.
7. Warranty	
GCC 13.2	<p>The period of validity of the Warranty shall be: <i>Twelve (12) months from the date of acceptance of goods at the place of destination by consignee as indicated in clause GCC 1.1 (f).</i></p> <p><i>As a proof of performance warranty, the supplier have to deposit 10% of the supplied value in the form of Bank Guarantee acceptable to the Purchaser which shall be valid for a period not less than twelve (12) months after delivery of last consignment.</i></p> <p style="text-align: center;"><i>Or</i></p> <p><i>As a proof of performance warranty, the purchaser will not release the 10% retention money to cover the defects liability period which shall be minimum of twelve months after the delivery of the last consignment. However, the payment for the retention amount shall be made provided the Supplier presents request for payment accompanied by a Retention Security in the form of Bank Guarantee issued by a reputable financial institution acceptable to the purchaser for an amount equal to the amount of retention payment and the validity of the Bank Guarantee shall be not less than twelve (12) months after the delivery of last consignment.</i></p> <p><i>If the Financial institution issuing the performance warranty bank guarantee/retention security bank guarantee furnished by the Bidder is located outside the Purchaser's country, the bank guarantee shall be counter guaranteed by:</i></p>

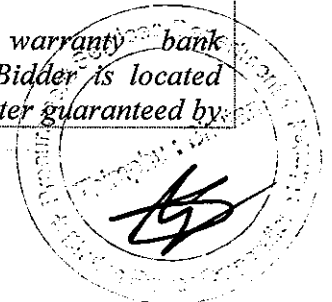

	<i>a correspondent financial institution located in the Purchaser's country to make it enforceable.</i>
8. Payment	
GCC 14.1	<p>Payments shall be made in equivalent Ngultrum to the currency quoted amount but the payment shall be made through proper banking channels and the responsibilities of payment transfer and transfer charges lie on the Suppliers.</p> <p>Undertaking letter from routing of payment through the Banks (if the payment is not through Letter of Credit) shall not be issued.</p> <p>Payment of the Contract Price shall be made in through the following manner:</p> <ul style="list-style-type: none"> a) Advance Payment: Maximum of ten percent (10%) of the Contract Price as advance payment shall be paid after signing of the contract. Payment shall be made provided the Supplier presents a request for payment accompanied by an Advance Payment Security in the form of Bank Guarantee issued by a reputable financial institution acceptable to the purchaser for an amount equal to the amount of the advance payment, and shall be valid until the goods are delivered. b) On Acceptance: Eighty percent (80%) of the contract price of the goods received shall be paid within thirty (30) days of receipt of the goods upon the submission of a claim supported by the Acceptance Certificate / Good Receipt Note (GRN) issued by the Purchaser. c) Retention payment: Ten percent (10%) of the Contract Price will be payable after the expiry of defect liability period (for a period not exceeding twelve months after delivery of all materials). However, payment shall be made provided the Supplier presents a request for payment accompanied by retention Security in the form of Bank Guarantee issued by a reputable financial institution acceptable to the purchaser for an amount equal to the amount of the retention payment, and shall be valid for a period not less than twelve (12) months after delivery of all materials. <p>If the Financial institution issuing the advance payment bank guarantee/retention security bank guarantee furnished by the Bidder is located outside the Purchaser's country, the bank guarantee shall be counter guaranteed by a correspondent Financial Institutions located in the Purchaser's country to make it enforceable.</p>
9. Contract Prices	
GCC 15.2	The prices charged for the Goods supplied and the related Services performed <i>shall not</i> be adjustable.
10. Contract Execution Schedule and Extension in the Supplier's Performance	
GCC 16.1	<p>The contract shall be executed as per Contract Execution Schedule given below:</p> <p><i>The commencement of the contract period shall be assumed from the date of signing of the contract agreement if an agreement is executed; otherwise the notification of award is an acceptance and shall constitute a contract between the parties.</i></p>



Section VIII- Contract Forms

Phase	Activity	Remarks
<p><i>The Supplier shall submit a detailed program covering the manufacturing, testing and delivery of the materials and equipment within the time stated in the bid documents. The program shall be in the form of bar chart. The Supplier shall submit progress reports detailing progress and explaining any variations if any.</i></p>		
<p>11. Liquidated Damages</p>		
GCC 17.1	The liquidated damages shall be: <i>1 % per week.</i>	
GCC 17.1	The maximum amount of liquidated damages shall be: <i>10 % of the contract value.</i>	
<p>12. Resolution of Disputes</p>		
GCC 21.2	The rules of procedure for arbitration proceedings pursuant to GCC Sub-Clause 21.2 shall be as per the Alternative Dispute Resolution Act of Bhutan 2013.	
<p>13. Taxes and Duties</p>		
GCC 26.1	Pursuant to GCC 26.1	
	<p>a. Price quoted shall be inclusive of all taxes (both inside and outside the purchaser's country) and Purchaser shall not be responsible and liable for the reimbursement/payment of taxes and duties. Further, for the clarity of applicable taxes, the Bidders may check with Department of Revenue and Custom, Ministry of Finance, Thimphu Bhutan / for exact Tax Rates in Bhutan for goods offered from India/Third Countries that are payable in Bhutan;</p> <p>b. The manufacturer(s) in Bhutan are to pay the taxes in accordance with the rules of the Government without any liability to the Purchaser. Purchaser shall not be responsible for reimbursement/processing exemptions/payments of taxes, duties, levies, royalties etc. for raw materials; and</p> <p>c. Tax Deducted at Source (TDS) shall be deducted as per the regulations of Ministry of Finance, RGoB, Bhutan.</p>	

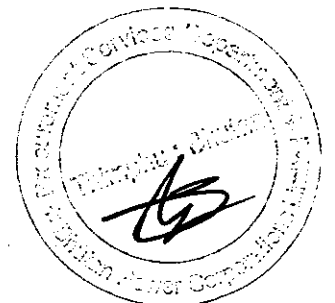

Section VIII. Contract Forms

Table of Contents

Contract Agreement..... 7
Performance Security.....9
Bank Guarantee for Advance Payment.....10

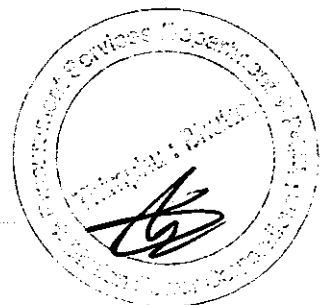

Contract Agreement

THIS CONTRACT AGREEMENT made on the [insert number] day of [insert month], [insert year],

BETWEEN

[insert complete *name of Purchaser*] of Bhutan Power Corporation and having its principal place of business at [insert address of Purchaser (hereinafter "the Purchaser")] of the one part and

[insert *name of Supplier*], a corporation incorporated under the laws of [insert: *country of Supplier*] and having its principal place of business at [insert address of *Supplier*](hereinafter "the Supplier") of the other part.

WHEREAS the Purchaser is desirous that certain goods be provided by the Supplier, viz., [insert *Brief Description of Goods, as identified in the Bid Form and Price Schedule*](hereinafter "the Goods") and has accepted a Bid by the Supplier for the provision of those Goods in the sum of [insert *Contract Price in Words and Figures*] (hereinafter "the Contract Price").

NOW THIS CONTRACT AGREEMENT WITNESSETH AS FOLLOWS:

1. In this Agreement words and expression shall have the same meaning as are respectively assigned to them in the Conditions of Contract referred to.
2. The following documents shall constitute the Contract between the Purchaser and the Supplier, and each shall be read and construed as an integral part of the Contract:
 - a. This Contract Agreement;
 - b. The Purchaser's Notification of Award;
 - c. Minutes of Contract Negotiation Meeting;
 - d. Price Schedule;
 - e. Special Conditions of Contract;
 - f. General Conditions of Contract;
 - g. Technical Requirements;
 - h. The Supplier's Bid and original Price Schedule;
 - i. Integrity Pact;
 - j. VPMS Acceptance Form
3. This Contract shall prevail over all other Contract documents. In the event of any discrepancy or inconsistency within the Contract documents, then the documents shall prevail in the order listed above.
4. In consideration of the payments to be made by the Purchaser to the Supplier as

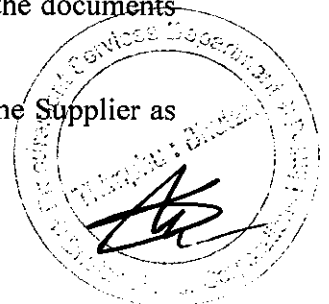

hereinafter mentioned, the Supplier hereby covenants with the Purchaser to provide the Goods and to remedy defects therein in conformity in all respects with the provisions of the Contract.

5. The Purchaser hereby covenants to pay the Supplier, in consideration of the provision of the Goods and the remedying of defects therein, the Contract Price or such other sum as may become payable under the provisions of the Contract, at the times and in the manner prescribed by the Contract.

IN WITNESS WHEREOF, the parties hereto have caused this Contract Agreement to be executed in accordance with the laws of Bhutan on the day, month and year indicated above

For and on behalf of the Purchaser

Signed: [insert signature]
in the capacity of [insert title or other appropriate designation]

in the presence of [insert signature]
[insert identification of official witness]

For and on behalf of the Supplier

Signed: [insert signature of authorized representative(s) of the Supplier]
in the capacity of [insert title or other appropriate designation]

in the presence of [insert signature]
[insert identification of official witness]

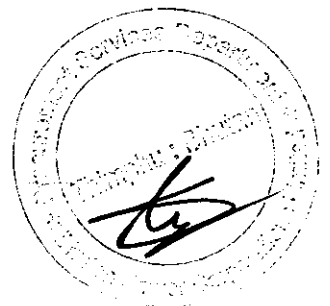

Performance Security

[The bank, as requested by the successful Bidder, shall fill in this form in accordance with the instructions indicated]

Date: *[insert date (as day, month, and year) of Bid submission]*
IFB No. and title: *[insert no. and title of bidding process]*

Bank's Branch or Office: *[insert complete name of Guarantor]*

Beneficiary: *[insert complete name of Purchaser]*

PERFORMANCE GUARANTEE No.: *[insert Performance Guarantee number]*

We have been informed that *[insert complete name of Supplier]* (hereinafter called "the Supplier") has entered into Contract No. *[insert number]* dated *[insert day and month]*, *[insert year]* with you, for the supply of *[description of Goods and related Services]* (hereinafter called "the Contract").

Furthermore, we understand that, according to the conditions of the Contract, a Performance Guarantee is required.

At the request of the Supplier, we hereby irrevocably undertake to pay you any sum(s) not exceeding *[insert amount(s)¹ in figures and words]* upon receipt by us of your first demand in writing declaring the Supplier to be in default under the Contract, without cavil or argument, or you needing to prove or to show grounds or reasons for your demand or the sum specified therein.

This Guarantee shall expire no later than the *[insert number]* day of *[insert month]* *[insert year]*,² and any demand for payment under it must be received by us at this office on or before that date. We agree to a one-time extension of this Guarantee for a period not to exceed *[six months]* *[one year]*, in response to the Purchaser's written request for such extension, such request to be presented to us before the expiry of the Guarantee.

[signatures of authorized representatives of the bank]

¹ The Bank shall insert the amount(s) specified in the SCC and denominated, as specified in the SCC, either in the currency(ies) of the Contract or a freely convertible currency acceptable to the Purchaser.

² Date established in accordance with General Conditions of Contract ("GCC"). The Purchaser should note that in the event of an extension of the time to perform the Contract, the Purchaser would need to request an extension of this Guarantee from the Bank. Such request must be in writing and must be made prior to the expiration date established in the Guarantee.

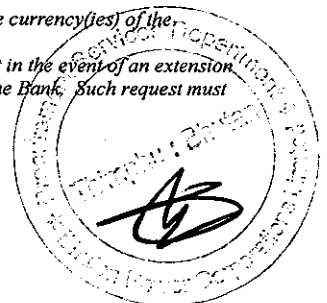

Bank Guarantee for Advance Payment

[The bank, as requested by the successful Bidder, shall fill in this form in accordance with the instructions indicated.]

Date: *[insert date (as day, month, and year) of Bid submission]*

IFB No. and title: *[insert number and title of bidding process]*

[bank's letterhead]

Beneficiary: *[insert legal name and address of Purchaser]*

ADVANCE PAYMENT GUARANTEE No.: *[insert Advance Payment Guarantee no.]*

We, *[insert legal name and address of bank]*, have been informed that *[insert complete name and address of Supplier]* (hereinafter called "the Supplier") has entered into Contract No. *[insert number]* dated *[insert date of Contract]* with you, for the supply of *[insert types of Goods to be delivered]* (hereinafter called "the Contract").

Furthermore, we understand that, according to the conditions of the Contract, an advance payment is to be made against an advance payment guarantee.

At the request of the Supplier, we hereby irrevocably undertake to pay you any sum or sums not exceeding in total an amount of *[insert amount(s)³ in figures and words]* upon receipt by us of your first demand in writing declaring that the Supplier is in breach of its obligation under the Contract because the Supplier used the advance payment for purposes other than toward delivery of the Goods.

It is a condition for any claim and payment under this Guarantee to be made that the advance payment referred to above must have been received by the Supplier in its account *[insert number and domicile of the account]*

This Guarantee shall remain valid and in full effect from the date of the advance payment received by the Supplier under the Contract until *[insert date⁴]*. We agree to a one-time extension of this Guarantee for a period not to exceed *[six months][one year]*, in response to the Purchaser's written request for such extension, such request to be presented to us before the expiry of the Guarantee.

[signature(s) of authorized representative(s) of the bank]

³ The bank shall insert the amount(s) specified in the SCC and denominated, as specified in the SCC, either in the currency(ies) of the Contract or a freely convertible currency acceptable to the Purchaser.

⁴ Insert the Delivery date stipulated in the Contract Delivery Schedule. The Purchaser should note that in the event of an extension of the time to perform the Contract, the Purchaser would need to request an extension of this Guarantee from the bank. Such request must be in writing and must be made prior to the expiration date established in the Guarantee

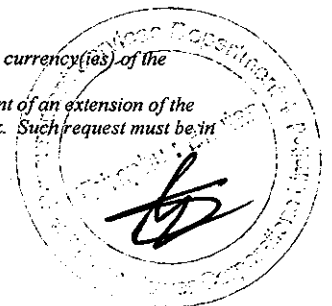

For Reference only.

SHIELD WIRE CROSSARM ASSEMBLY
ISM 75X40. 1 NO.

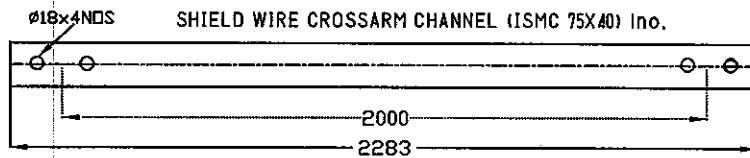
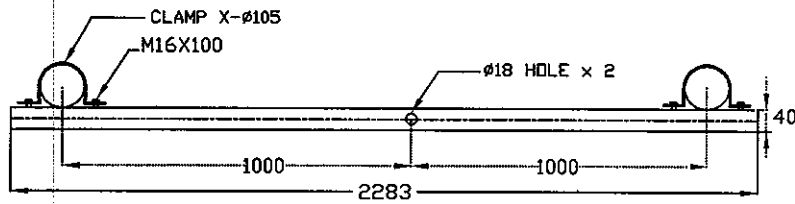

CROSS ARM CHANNEL (ISM 100x50) 2 NOS

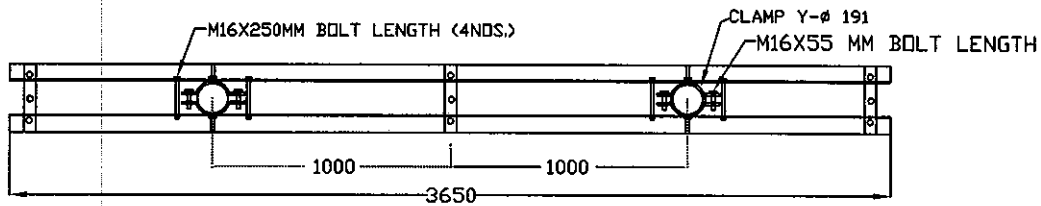

CROSS ARM CHANNEL (ISM 100x50) - ELEVATION

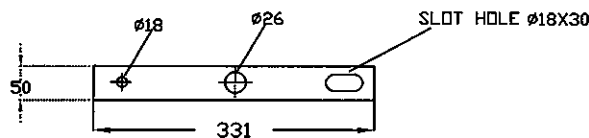
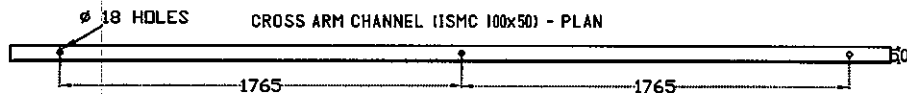

MS TENSION STRAP (50x6) - 6 NOS
M16x 185 MM BOLT LENGTH - 6 NOS

NOTES

1. DIMENSIONS AS SHOWN ARE IN mm.
2. DRAWING IS NOT TO SCALE.



BHUTAN POWER CORPORATION LIMITED

ENGINEERING AND RESEARCH DEPARTMENT

TITLE : DISTRIBUTION DESIGN & CONSTRUCTION STANDARD

DOUBLE POLE ASSEMBLY FOR 12 M TELESCOPIC POLE WITH GROUNDWIRE (11 KV & 33KV)

	NAME	DATE
DESIGNED BY		
CHECKED BY		
APPROVED BY		

DRAWING NO. BPC-DDCS-2020-19/9-20

REVISION
2020

For Reference only.

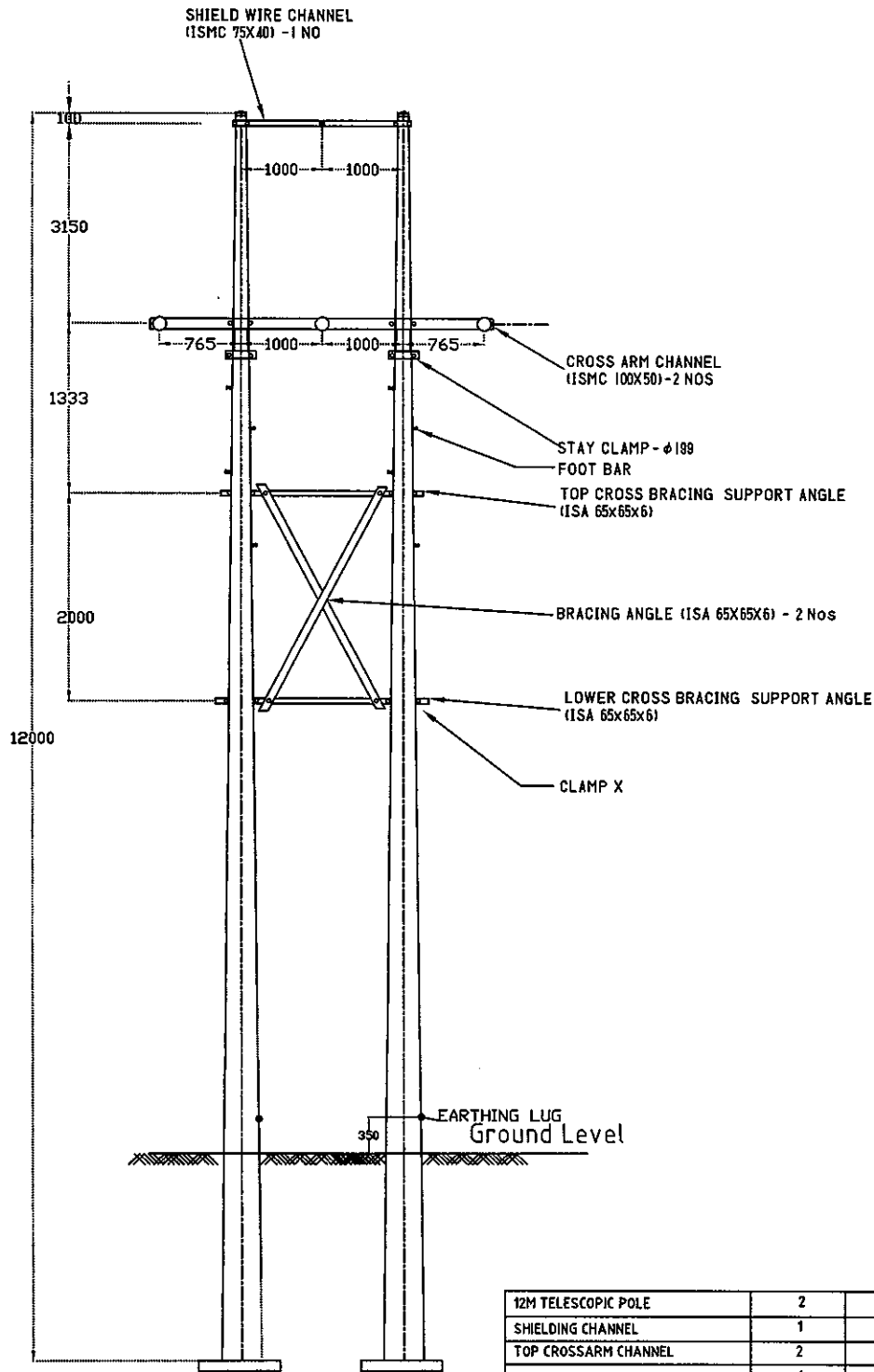

NOTES

DIMENSIONS AS SHOWN ARE IN mm.
DRAWING IS NOT TO SCALE.

12M TELESCOPIC POLE	2	GS
SHIELDING CHANNEL	1	GS
TOP CROSSARM CHANNEL	2	GS
DISC INSULATOR SET	6	PORCELAIN
PIN INSULATOR SET	3	PORCELAIN
CLAMP WITH NUTS & BOLTS	1	GS
BRACING ANGLE SET	1	GS
STAY CLAMP SET	2	GS
DESCRIPTION	QTY	MATERIAL



BHUTAN POWER CORPORATION LIMITED

ENGINEERING AND RESEARCH DEPARTMENT

DISTRIBUTION DESIGN & CONSTRUCTION STANDARD

DOUBLE POLE ASSEMBLY FOR 12 M TELESCOPIC POLE WITH GROUNDWIRE (11 KV & 33KV)

	NAME	DATE
DESIGNED BY		
CHECKED BY		
APPROVED BY		

DRAWING NO. BPC-DDCS-2020-19/8-20

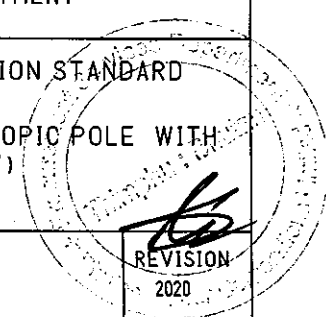

for Reference only.

ANGLE FOR TOP CROSS BRACING SUPPORT (ISA 65x65x6) - 1 NO

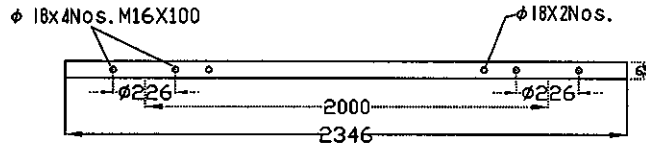

ANGLE FOR LOWER CROSS BRACING SUPPORT (ISA 65x65x6) - 1 NO

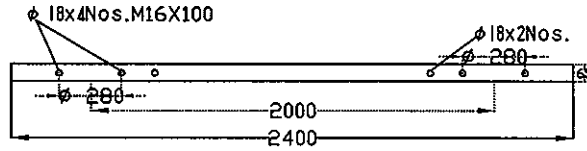

ANGLE FOR CROSS BRACING (ISA 65 x 65 x 6) - 2 NOS

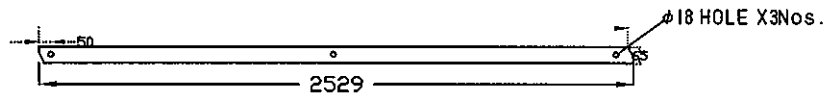

SHIELDING ARRANGEMENT ON DOUBLE POLE STRUCTURES

SHIELD WIRE CHANNEL

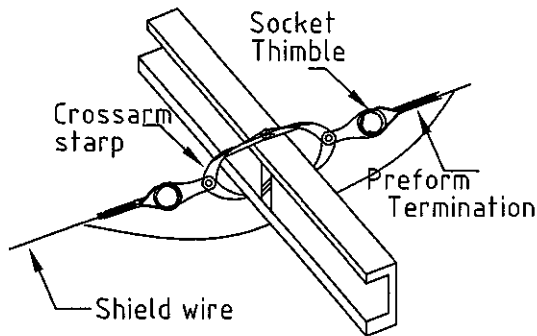

NOTES

1. DIMENSIONS AS SHOWN ARE IN mm.
2. DRAWING IS NOT TO SCALE.
3. LENGTH OF THE CROSS BRACING ANGLE SHALL BE DESIGNED BY THE SUPPLIER



BHUTAN POWER CORPORATION LIMITED

ENGINEERING AND RESEARCH DEPARTMENT

TITLE : DISTRIBUTION DESIGN & CONSTRUCTION STANDARD
DOUBLE POLE ASSEMBLY FOR 12 M TELESCOPIC POLE WITH
GROUNDWIRE (11 KV & 33KV)

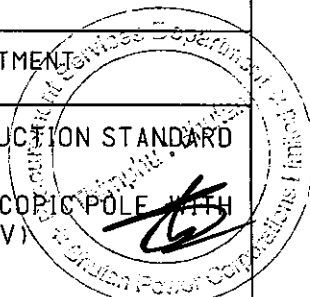

	NAME	DATE
DESIGNED BY		
CHECKED BY		
APPROVED BY		

DRAWING NO. BPC-DDCS-2020-19/10-20

REVISION
2020

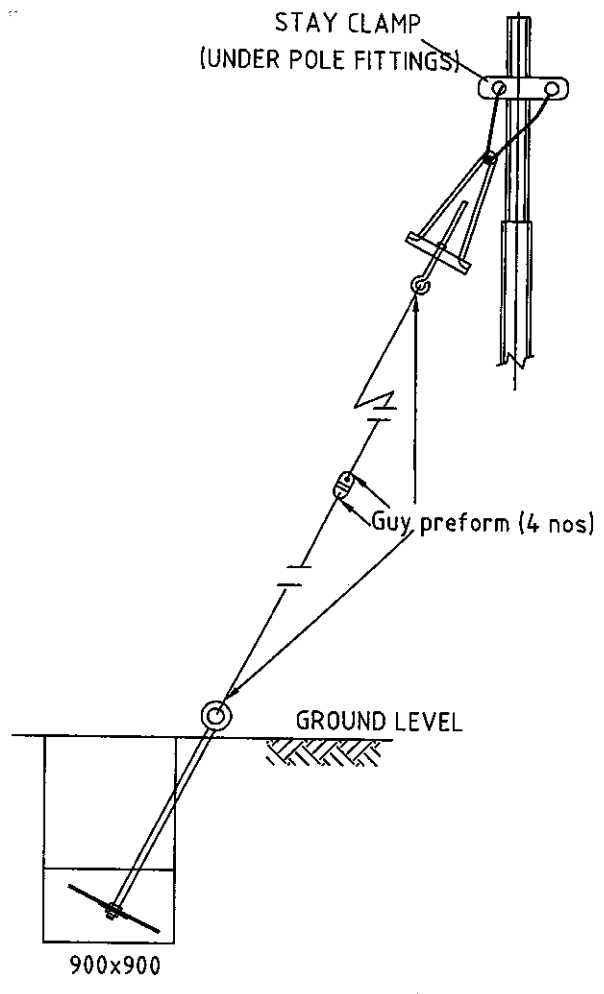
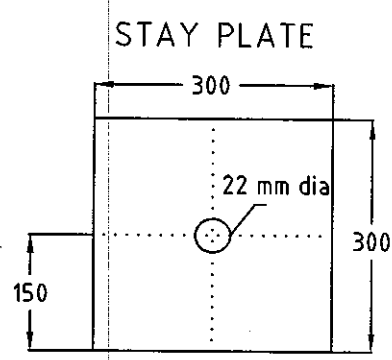
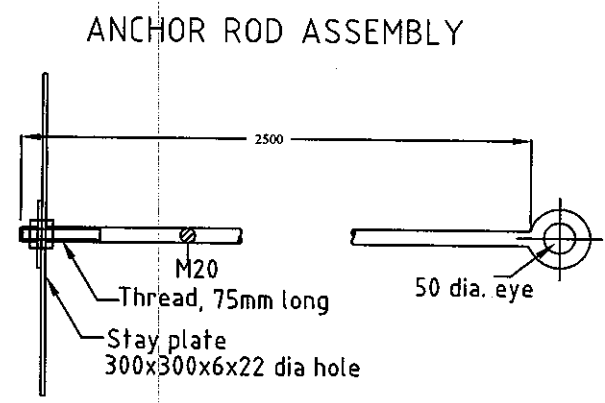
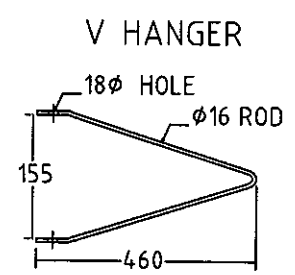
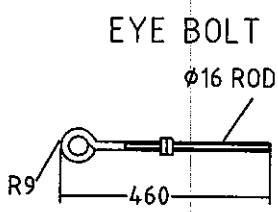
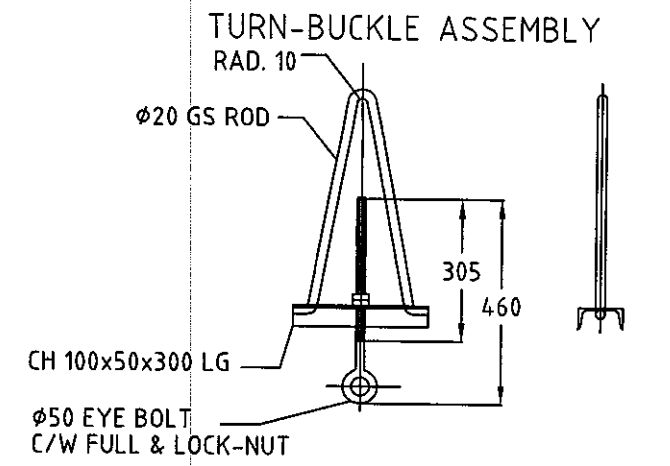

NOTES
 Stay rod and nuts assembled and packed together
 Anchor plates packed separately
 Material :- BS 4360 Grade 43A
 Galvanizing :- BS 729
 Threads :- ISO Metric
 Nut :- BS 4190 Grade 4.0

V-HANGER	1	H.D.G STEEL
STAY WIRE (7/8 SWG) (IN METERS)	IM+POLE HEIGHT	H.D.G STEEL
STAY ROD (2.5 M) WITH THIMBLE	1	H.D.G STEEL
ANCHOR PLATE (300 X 300 X 6MM)	1	H.D.G STEEL
TURN BUCKLE ASSEMBLY WITH THIMBLE	1	H.D.G STEEL
GUY PREFORMED SUITABLE FOR 7/8 SWG	4	GALVANISED STEEL WIRE
STAY INSULATOR	1	PORCELAIN
NAME OF THE ITEM	QTY	MATERIAL

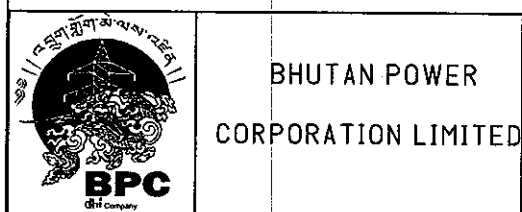

BHUTAN POWER CORPORATION LIMITED

ENGINEERING AND RESEARCH DEPARTMENT

DISTRIBUTION DESIGN & CONSTRUCTION STANDARD

STAY SET ASSEMBLY FOR TELESCOPIC POLE

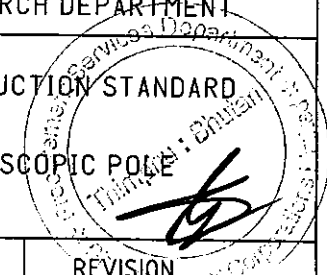

TITLE	NAME	DATE
DESIGNED BY		
CHECKED BY		
APPROVED BY		

DRAWING NO. BPC-DDCS-2020-22/2-2

REVISION 2020

1
2
3

Guaranteed Technical Particulars (GTP) of HV ABC			
			Bidders to fill up
SL. No.	Parameters	Units	HV ABC
			3 core 95 sq. mm
1	Manufacturer		
2	Applicable Standards		
3	Rated voltage	kV	
	Conductor		
4	Nominal Area of core Conductor	mm ²	
5	Conductor Screen Material		
6	Min. Thickness of Conductor Screen	mm	
	Insulation		
7	Insulation material		
8	Minimum Insulation thickness	mm	
9	Minimum thickness of insulation screen	mm	
	Metallic Shield		
10	Material		
11	Size for Conductor screen	No./mm	
	Sheath		
12	Material		
13	Min. thickness	mm	
	Support Catenary		
14	Support Catenary size	No./mm	
15	Material		
	Test Voltage		
16	Power frequency withstand voltage	kV/5min	
17	Max. Current Rating at 35 ⁰ C	A	
18	Type of cable end sealing		
	Cable drums		
a.	Dimensions	Mtr.	
b.	Weight	Kg	
c.	Nominal Length per drum	Mtr.	

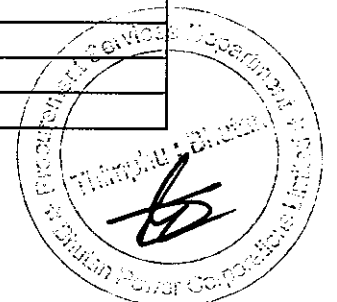

Guaranteed Technical Particulars (GTP) of LV ABC

SL. No.	Parameters	Units	Bidders to fill up			
			2 core 50 sq.mm	2 Core 95sq.mm	4 core 50 sq.mm	4 core 95 sq.mm
1	Manufacturer					
2	Applicable Standards					
3	Rated voltage	kV				
	Conductor					
4	Nominal Area of core Conductor	mm ²				
	Insulation					
5	Insulation material					
6	Minimum Insulation thickness	mm				
	Test Voltage					
7	Power frequency withstand voltage	kV/5min				
8	Max. Current Rating at 35°C	A				
9	Type of cable end sealing					
10	Cable drums					
a.	Dimensions	Mtr.				
b.	Weight	Kg				
c.	Nominal Length per drum	Mtr.				

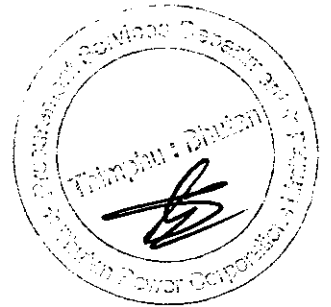

Item no. 1: 33 kV Stay Insulator

SI No	Parameters	Unit	Bidders to Fill up
1	Applicable Standards		
2	Material of insulator		
3	Cantilever Strength	kN	
4	Nominal Diameter	mm	
5	Nominal height	mm	
6	Nominal Creepage distance	mm	
7	Minimum power frequency flashover voltage		
	- dry	kV	
	- wet	kV	
8	Puncture voltage	kV	
9	Weight (Approximate)	kg	

Item No. 2: 33kV Polymer Strain Insulator with Fitting Assembly

SI No	Description of parameters	Unit	Bidders to Fill up
1	Applicable standards		
2	Material of insulator		
3	Specified mechanical failing load	kN	
4	Arching distance	mm	
5	Nominal spacing	mm	
6	Nominal creepage distance	mm	
7	Minimum power frequency flashover voltage		
	- dry	kV	
	- wet	kV	
8	Puncture voltage	kV	
9	Length between ball and socket couplings (IEC 120/IEC 61466-1)	mm	
10	Weight (Approximate)	kg	

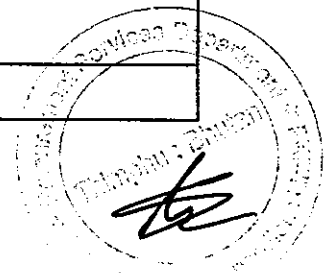

Price Schedule

Brand Restricted to: PT KMI Wires and Cables Tbk, PT Sucaco Tbk, PT Voksel Electric Tbk, PT Jembo Cables Company Tbk and Zhongli Science & Technology, China.

Sl.No.	Material No.	Description	UoM	Qty	Brand and Country of Origin	Unit Price DDP (Nu.)	Amount DDP (Nu.)
Lot. 1 HV ABC							
1	172	HV ABC 6.35/11kV grade 3 core, 95sqmm	KM	8.50			
Lot. 2 LV ABC							
3	174	LV ABC Conductor for 2x50 sqmm	KM	88.77			
4	175	LV ABC Conductor 2 core, 95sqmm	KM	2.00			
5	178	LV ABC Conductor for 4x50 sqmm	KM	109.66			
6	179	LV ABC Conductor for 4x95 sqmm	KM	41.97			
7	180	LV ABC Conductor 4 core, 120sqmm	KM	10.09			

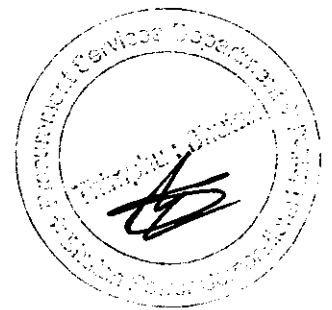

Price Schedule

Lot 3. Telescopic Pole Fittings							
Sl. No	Material No.	Material Description	UoM	Qty	Rate DDP (Nu.)	Amount DDP (Nu.)	Remarks
1	1283	Shield Wire X-arm for 12m Tele Pole	SET	136.00			As per Sample
2	1283	Shield Wire X-arm for 12m Tele Pole	SET	144.00			As per Sample
3	1291	33kV double pole X-arm 12m Tele pole	SET	151.00			As per Sample
4	1293	33kV double pole X-brace 12m Tele pole	SET	176.00			As per Sample
5	552	GI stay set assembly	SET	540.00			
6	490	GI Stay wire 7/8 SWG	KG	7829.00			
7	2088	GI stranded Earth Shield Wire 7/2 mm	KM	91.00			

Note: The bidder are advised to inspect the samples from PSD warehouse before mass fabrication. If the materials delivered are not as per samples, materials would be rejected.

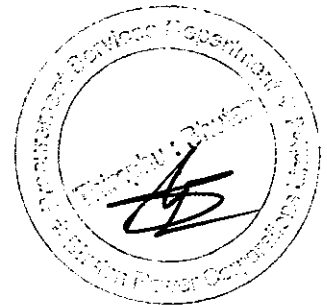

Price Schedule

Lot 4. Insulator with Fittings Accessories						
Sl. No	Material Description	UoM	Total	Rate DDP (Nu.)	Amount DDP (Nu.)	Remarks
1	33 kV Stay Insulator	NO	860.00			
2	33kV Polymer Strain insulator with fitting assembly	SET	2256.00			

