

BHUTAN POWER CORPORATION LIMITED

(An ISO 9001:2015, ISO 14001:2015 & OHSAS 18001:2007 Certified Company)

REGISTERD OFFICE: THIMPHU

ELECTRICITY SERVICES DIVISION

SAMDRUP JONGKHAR: BHUTAN



BIDDING DOCUMENT

FOR

**LABOUR CONTRACT ON PLAN AND O&M WORKS
UNDER ESD SAMDRUP JONGKHAR**

Tender No.: BPC/ESD/SJ/TECH-11/2021/08 dated 5th February 2021



CONTENTS

1. Integrity Pact
2. Section I - Invitation for Bids
3. Section II - Instructions to Bidders
4. Section III - Conditions of Contract
5. Section IV - Technical Specifications
6. Section V - Price Schedules
7. Section VI - Bid Form
8. Section VII - Sample Forms
9. Drawings
10. Sample Bill of Quantities



INTEGRITY PACT



INTEGRITY PACT

1 General:

Whereas,

representing the Bhutan Power Corporation Limited, Royal Government of Bhutan, hereinafter referred to as the “**Employer**” on one part, and _____ (*Name of bidder or his/her authorized representative, with power of attorney*) representing M/s. _____ (*Name of Firm*) as the other part hereby execute this agreement as follows:

This agreement should be a part of the tender document, which shall be signed by both the parties at the time of purchase of bidding documents and submitted along with the tender document. This IP is applicable only to “**Small**” scale works, goods and services, the threshold of which will be announced by the government from time to time. The signing of the IP shall not apply to framework contracting such as annual office supplies etc.

2 Objectives:

Whereas, the Employer and the Bidder agree to enter into this agreement, hereinafter referred to as IP, to avoid all forms of corruption or deceptive practice by following a system that is fair, transparent and free from any influence/unprejudiced dealings in the **bidding process**¹ and **contract administration**², with a view to:-

- 2.1 Enabling the Employer to obtain the desired contract at a reasonable and competitive price in conformity to the defined specifications of the works, goods or services; and
- 2.2 Enabling bidders to abstain from bribing or any corrupt practice in order to secure the contract by providing assurance to them that their competitors will also refrain from bribing and other corrupt practices

3. Scope

The validity of this IP shall cover the bidding process and contract administration period.

4. Commitments of the Employer:

The Employer Commits itself to the following:-

- 4.1 The Employer hereby undertakes that no official of the Employer, connected directly or indirectly with the contract, will demand, take a promise for or accept, directly or through intermediaries, any bribe, consideration, gift, reward, favor or any material or immaterial benefit or any other advantage from the Bidder, either for themselves or for any person, organization or third

¹ Bidding process, for the purpose of this IP, shall mean the procedures covering tendering process starting from bid preparation, bid submission, bid processing, and bid evaluation.

² Contract Administration, for the purpose of this IP, shall mean contract award, contract implementation, un-authorized sub-contracting and contract handing/taking over.



party related to the contract in exchange for an advantage in the bidding process and contract administration.

- 4.2 The Employer further confirms that its officials has not favored any prospective bidder in any form that could afford an undue advantage to that particular bidder in the bidding process and contract administration and will treat all Bidders alike.
- 4.3 Officials of the Employer, who may have observed or noticed or have reasonable suspicion shall report to the head of the employing agency or an appropriate government office any violation or attempted violation of clauses 4.1 and 4.2.
- 4.4 Following report on violation of clauses 4.1 and 4.2 by official (s), through any source, necessary disciplinary proceedings, or any other action as deemed fit, including criminal proceedings shall be initiated by the Employer and such a person shall be debarred from further dealings related to the bidding process and contract administration.

5 Commitments of Bidders:

The Bidder commits himself/herself to take all measures necessary to prevent corrupt practices, unfair means and illegal activities during any stage of the bidding process and contract administration in order to secure the contract or in furtherance to secure it and in particular commits himself/herself to the following :-

- 5.1 The Bidder shall not offer, directly or through intermediaries, any bribe, gift, consideration, reward, favor, any material or immaterial benefit or other advantage, commission, fees, brokerage or inducement to any official of the Employer, connected directly or indirectly with the bidding process and contract administration, or to any person, organization or third party related to the contract in exchange for any advantage in the bidding process and contract administration.
- 5.2 The Bidder shall not collude with other parties interested in the contract to manipulate in whatsoever form or manner, the bidding process and contract administration.
- 5.3 If the bidder(s) have observed or noticed or have reasonable suspicion that the provisions of the IP have been violated by the procuring agency or other bidders, the bidder shall report such violations to the head of the procuring agency.

6 Sanctions for Violation:

The breach of any of the aforesaid provisions shall result in administrative charges or penal actions as per the relevant rules and laws.

- 6.1 The breach of the IP or commission of any offence (forgery, providing false information, mis-representation, providing false/fake documents, bid rigging, bid steering or coercion) by the Bidder, or any one employed by him, or acting on his/her behalf (whether with or without the knowledge of the Bidder), shall



be dealt with as per the terms and conditions of the contract and other provisions of the relevant laws including De-barment Rules.

6.2 The breach of the IP or commission of any offence by the officials of the procuring agency shall be dealt with as per rules and laws of the land in vogue.

7. Monitoring and Administration:

7.1 The respective procuring agency shall be responsible for administration and monitoring of the IP as per the relevant laws.

7.2 The bidder shall have the right to appeal as per the arbitration mechanism contained in the relevant rules.

We, hereby declare that we have read and understood the clauses of this agreement and shall abide by it.

The parties hereby sign this Integrity Pact at _____
on _____

Affix
Legal
Stamp

Affix
Legal
Stamp

EMPLOYER

BIDDER/REPRESENTATIVE

CID:

CID:

Witness: _____

Witness: _____

Name:

Name:

CID:

CID:



Section I

INVITATION FOR BIDS





འབྲུག་གློག་ལེ་ལས་འཛིན།
Bhutan Power Corporation Limited
 (An ISO 9001:2015, ISO 14001:2015 & OHSAS 18001:2007 Certified Company)
 Registered Office, Thimphu
Electricity Services Division
 Samdrup Jongkhar : Bhutan



No: BPC/ESD/SJ/Tech-11/2021/ 08

4 February 2021

To
 The General Manager,
 Advertising Department,
 Kuensel Corporation Limited,
 Thimphu: Bhutan.

Subject: **Publishing of NIQ in Kuensel (English edition) of 05th February 2021**

Dear Sir,

Kindly arrange to publish the following advertisement in the Kuensel (**English** edition) of 5th February 2021

	Bhutan Power Corporation Limited <i>(An ISO 9001:2015, ISO 14001:2015 & OHSAS 18001:2007 Certified Company)</i> Registered Office, Thimphu Electricity Services Division Samdrup Jongkhar: Bhutan
Tender No. : BPC/ESD/SJ/Tech-11/2021/08	05 th February 2021
The Bhutan Power Corporation Limited (BPC) invites sealed bids from Small Class categories of Bhutanese National Contractors with W4 (Power and Telecommunications) having valid Trade License and registered with the Construction Development Board (CDB) for the works mentioned below:	
Name of Works: Labour Contract on Plan and O&M Works under ESD, Samdrup Jongkhar (Electrical Work) under the following packages: 1)Package:SJE01-2021, 2)Package:SJE02-2021, 3)Package:SJE03-2021, 4)Package:SJE04-2021, 5)Package:SJE05-2021	
Bid Details a) Sale of Bid Document b) Cost of Bid Document c) Place of Sale d) Last Date of Submission e) Place of Submission f) Opening Date g) Place of Opening	8 th February 2021 to 10 th March 2021 Nu. 1000.00 each (Non-refundable) FAS, ESD, BPC, Samdrup Jongkhar 12 th March 2021 (1200 Hours) FAS, ESD, BPC Samdrup Jongkhar 12 th Mach 2021 (1430 Hours) Conference Hall, ESD, BPC, Samdrup Jongkhar
The detailed bidding documents can be purchased from the office of the Finance Officer, Finance & Accounts Section, Electricity Services Division, BPC, Samdrup Jongkhar upon submission of copies of valid Trade license, CDB registration certificate and Tax clearance certificates with appropriate written application. Bidding documents can also be downloaded from BPC website, www.bpc.bt . For any other queries, please contact Divisional Manager at 171311471/ 07-251135.	
Divisional Manager	

Yours faithfully,

(Tshewang Dorji)
Divisional Manager

Copy to : Finance Officer, FAS, ESD, BPC, Samdrup Jongkhar for information.

**SECTION I
INVITATION FOR BIDS**

Tender No.: BPC/ESD/SJ/Tech-11/2021/08

5th February 2021

1. BPC invites sealed bids from the below mentioned Class categories of Bhutanese National contractors with W4 (Power and telecommunications) valid License and registered with the Construction Development Board for the works as mentioned below:

Name of Work: **Labour Contract on Plan and O&M Works under ESD, Samdrup Jongkhar” (Electrical Work) under the following packages:**

Package No.	Description of Package	Duration of Contract	Estimate Amount (Nu.)	Bid Security Amount (Nu.)
SJE01-2021	ROW clearing at Samdrup Jongkhar	7 months	1.353 M	27,078.00
SJE02-2021	ROW clearing at Samdrupcholing	7 months	1.053 M	21,052.00
SJE03-2021	ROW clearing at Jomotsangkha	7 months	1.335 M	26,719.00
SJE04-2021	Plan & Maintenance Works at Samdrup Jongkhar & Samdrupcholing	7 months	1.031M	20,612.00
SJE05-2021	Plan & Maintenance Works at Jomotsangkha	7 months	0.942 M	18,839.00
Bid Details		a) Sale of Bid Document b) Cost of Bid Document c) Place of Sale d) Last Date of Submission e) Place of Submission f) Opening Date g) Place of Opening		
		8 th February 2021 to 10 th March 2021 Nu. 1000.00 each (Non-refundable) FAS, ESD, BPC, Samdrup Jongkhar 12 th March 2021 (1200 Hours) FAS, ESD, BPC Samdrup Jongkhar 12 th Mach 2021 (1430 Hours) Conference Hall, ESD, BPC, Samdrup Jongkhar		

2. The detailed bidding documents can be purchased from the office of the Finance Officer, Finance & Accounts Section, Electricity Services Division, BPC, Samdrup Jongkhar upon submission of copies of valid Trade license, CDB registration certificate and Tax clearance certificates with appropriate written application. For any other queries, please contact Divisional Manager at 17131147/ 07-251135.
3. The prospective bidders can also download the Bidding documents for free from BPC website, www.bpc.bt. However, the bidders who have downloaded and printed the bidding documents by themselves should register with Finance & Accounts Section, Electricity Services Division, BPC, Samdrup Jongkhar on or before **1200 Hours of 12th March 2021**. The registration should be done through written application together with valid trade license, CDB's registration and tax clearance certificate. The bidders should bind the downloaded & printed document properly.

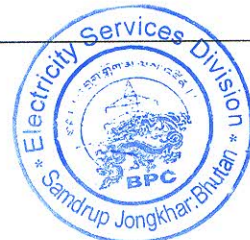

4. As per the prerequisite of Royal Government of Bhutan, interested Bidders should sign the Integrity Pact (IP) with Electricity Services Division, BPC, Samdrup Jongkhar at the time of purchase of bidding document. In order to sign the IP, the prospective Bidders should accompany a witness along with one legal stamp.
5. Bid must be accompanied by a Bid Security amount indicated against the package in Bhutanese Ngultrum (Nu.), and must be delivered in accordance with the Instructions to Bidders on the date indicated in the Bidding Documents and will be publicly opened thereafter.
6. BPC will not be responsible for any expenses incurred by bidders in connection with the preparation or delivery of bids.



Section II

INSTRUCTIONS TO BIDDERS



TABLE OF CONTENTS

Section – II

Instructions to Bidders

A. General	1
1. Scope of Bid	1
2. Eligible Bidders	1
3. Cost of Bidding and Site Visit.....	1
4. Contractor Information Network (CiNET).....	2
B. The Bidding Document	2
5 Bidding Document.....	2
6 Clarification of Bidding Documents	3
7 Amendments of Bidding Documents	3
C. Preparation of Bids	3
8 Language of Bid	3
9 Documents Comprising the Bid	3
10 Bid Form.....	4
11 Bid Prices.....	4
12 Bid Currencies	4
13 Documents Establishing Eligibility of the Bidder.....	4
14 Documents Establishing the Bidder’s Qualifications to Perform the Contract.....	5
15 Documents Establishing the Goods’ and Services Conformity to the Bidding Documents.....	5
16 Bid security.....	5
17 Period of Validity of Bids.....	6
18 Alternative Bids.....	7
19 Format and Signing of Bid	7
D. Submission of Bids	7
20 Sealing and Marking of Bids.....	7
21 Deadline for Submission of Bids.....	8
22 One Bid per Bidder.....	8
23 Late Bids.....	8
24 Modification and Withdrawal of Bids.....	8
E. Bid Opening and Evaluation	9
25 Opening of Bids by Employer.....	9
26 Process to be Confidential	9
27 Clarification of Bids	9
28 Preliminary Examination of Bids.....	10
29 Conversion to Ngultrum	10
30 Evaluation and Comparison of Bids.....	10
31 Contacting the Employer	11
32 Employer’s Right to Accept Any Bid and to Reject Any or All Bids.....	11
F. Award of Contract	12
33 Award	12
34 Employer’s Right to Vary Quantities at Time of Award	12
35 Notification of Award.....	12
36 Signing of Contract.....	13
37 Performance Security	13
38 Corrupt or Fraudulent Practices.....	13
39 Labour.....	14
40 Equal Pay	14



Section-II
Instructions to Bidders

A. General

1. Scope of Bid

1.1 Bhutan Power Corporation Limited (BPC) (hereafter referred to as “the Employer”) wishes to receive sealed Bids for **Labour Contract on Plan and O&M Works under ESD Samdrup Jongkhar**. The scope of works include construction, erection, testing, commissioning of LV lines and Service Connections, including loading, transportation, delivery of all materials and equipment to sites, storage, tree felling, clearance of ROW, dismantling, etc. (hereinafter referred to as “Works”). The works are classified under the following packages.

- (i) **Package SJE01-2021: ROW clearing at Samdrup Jongkhar**
- (ii) **Package SJE02-2021: ROW clearing at Samdrupcholing**
- (iii) **Package SJE03-2021: ROW clearing at Jomotsangkha**
- (iv) **Package SJE04-2021: Plan & Maintenance Works at Samdrup Jongkhar & Samdrupcholing**
- (v) **Package SJE05-2021: Plan & Maintenance Works at Jomotsangkha**

1.2 The successful bidder will be expected to complete the works within the stipulated time from the date of commencement of works as indicated in Article III, Clause No. 2 of Conditions of Contract.

2. Eligible Bidders

2.1 This Invitation for Bid is open to all Small Class Bhutanese registered Contractor with W4 (Power and Telecom holding valid Trade License, CDB registration and Tax Clearance Certificate).

2.2 Bidders shall provide such evidence of their eligibility satisfactory to the Employer, as the Employer shall reasonably request.

2.3 A Bidder shall not have a conflict of interest. All Bidders found to have conflict of interest shall be disqualified.

3. Cost of Bidding and Site Visit

3.1 The bidders shall bear all costs associated with the preparation and delivery of its Bid, and the Employer will in no case be responsible or liable for those costs.

3.2 The bidders are advised to visit to visit and examine the Site of Works and its surroundings and obtain on their own responsibility all information that may be necessary for preparing the bid, and entering into a contract for the Works. The costs of visiting the Site shall be at the bidder's own expense and at their own risk. Electricity Services Division, BPC, Samdrup Jongkhar will facilitate the site visit to the interested bidders.



The bidders shall make prior appointment for field visit before submitting the bid offer. The contact persons for the field visits shall be as below:

Tshewang Dorji,
Divisional Manager,
ESD, BPC, Samdrup Jongkhar
Telephone No. : +975-07-251135
Mobile No. : +975-17131147
Email: esdsjongkhar@bpc.bt

- 3.3 The bidders and any of their personnel or agents will be granted permission by the Employer to enter upon its premises and land for the purpose of such inspection, but only upon the condition that the bidders, their personnel and agents, will release and indemnify the Employer and its personnel and agents from and against all liability in respect thereof and will be responsible for death or personal injury, loss of or damage to property and any other loss, damage, costs and expenses incurred as a result of the inspection.

4. Contractor Information Network (CiNET)

- 4.1 The performance of the contractor shall be assessed as per the guidelines (average performance scoring form) contained in the CiNET available in the CDB website. **(Not Applicable)**
- 4.2 The average performance scoring (APS) forms is provided in the Section VII (Sample forms) of the bidding document. The bidders are required to initial all the pages of APS form agreeing to the applicability of APS form. In case the APS form is not signed, the bid for that bidder shall be liable for rejection **(Not Applicable)**.

B. The Bidding Document

5 Bidding Document

- 5.1 The bidding procedures and contract terms are prescribed in the Bidding Document. In addition to the Invitation for Bid, the Bidding Document includes:

- I Integrity Pact
- II Instructions to Bidders;
- III Conditions of Contract;
- IV Technical Specifications & Drawings;
- V Price Schedules & Sample Bill of Quantities;
- VI Bid Form; and
- VII **Sample Forms**
 - Bid Security Form
 - Contract Form
 - Performance Security Form
 - Bank Guarantee for Advance Payment
 - Power of Attorney Form
 - Form of information for establishment of Bidders' Eligibility



Form of information for establishment of Bidders' Qualification
Average Performance Scoring form

- 5.2 The bidders are expected to examine the Bidding Document, including all instructions, forms, terms and specifications. Failure to furnish all information required by Bidding Document or submission of a Bid not substantially responsive to the Bidding Document in every respect will result in the rejection of the Bid.

6 Clarification of Bidding Documents

- 6.1 Prospective bidders requiring any further information or clarification of the Bidding Document may notify the Employer in writing at the Employer's mailing address indicated under clause 20.2 The Employer will respond in writing to any request for information or clarification of the Bidding Documents, which it receives no later than ten (10) days prior to the deadline for submission of bids. The Employer's response including an explanation to the query will be sent in writing to all prospective bidders who purchased the Bidding Document.

7 Amendments of Bidding Documents

- 7.1 At any time prior to the deadline for submission of Bids, the Employer may, for any reason, whether at its own initiative or in response to a clarification requested by prospective bidder, modify the bidding Document by issuing addendum.
- 7.2 The amendment shall be part of the Bidding Document, pursuant to Sub-Clause 5.1, and it will be notified in writing or by fax to all prospective bidders who have received the Bidding Document, and will be binding on them.
- 7.3 In order to afford prospective bidders reasonable time in which to take the amendment into account in preparing their Bids, the Employer may, at its discretion, extend the dead line for the submission of Bids.

C. Preparation of Bids

8 Language of Bid

- 8.1 The Bids prepared by the bidder, and all correspondence and documents relating to the Bid exchanged by the Bidders and the Employer, shall be written in the English language.

9 Documents Comprising the Bid

- 9.1 The Bid prepared by the bidders shall comprise of the following components:
- (a) Bid Form and Price Schedule completed in accordance with Clause 10, 11, 12;
 - (b) Documentary evidence establishing, in accordance with Clause 13, that the bidder is eligible to bid.
 - (c) Documentary evidence establishing in accordance with Clause 14, that the bidder is qualified to perform the Contract if it's Bid is accepted;



(d) Bid security furnished in accordance with Clause 16.

(e) Written Power of Attorney authorizing the signature by bidders in accordance with Clause 19.2

10 Bid Form

10.1 The bidder shall complete **an original and a copy of the Bid Form and the appropriate Price Schedules** furnished in the Bidding Document.

Bid forms not duly filled and signed appropriately shall be treated as non-responsive and the bid shall be rejected.

11 Bid Prices

11.1 The bidders shall complete the appropriate Price Schedules included herein, stating the unit prices, total price per item and the total amount. Prices quoted shall follow strictly the format provided herein.

11.2 Unless stated otherwise in the bidding documents, the Contract shall be for the whole works, based on the schedule of unit rates and price submitted by the bidders.

11.3 The bidders shall fill in rates and prices for all items of the works described in the Bill of Quantities. Items against which no rate or prices is entered by the bidders will not be paid for by the Employer when executed and shall be deemed covered by the other rates and prices in the Bill of Quantities.

11.4 All duties, taxes and other levies payable by the Contractor under the contract, or any other cause, as of the date 7 days prior to the deadline for submission of bids shall be included in the rates and prices and the total bid price submitted by the bidder, and the evaluation and comparison of bids by the Employer shall be made accordingly.

11.5 Rates quoted by the bidder shall remain fixed and valid until completion of the Contract performance and will not be subject to variation on any account. A bid submitted with price adjustment condition will be treated as non-responsive and will be rejected.

11.6 Conditional tenders shall be rejected without any further explanation.

12 Bid Currencies

12.1 Rates shall be quoted in Ngultrum.

13 Documents Establishing Eligibility of the Bidder



- 13.1 The bidder shall furnish, as part of its Bid, certification establishing the bidder's eligibility to bid pursuant to Clause 2.
- 13.2 The bidder is a registered qualified electrical contractor. If in case, the license and the CDB registration certificate have expired during the bid submission, the bidder shall submit letters from competent authorities validating the documents.
- 13.3 The bidder does not anticipate change in ownership during the proposed period of work (if such a change is anticipated, the scope and effect thereof shall be defined).
- 13.4 The bidder shall submit proposals of work method and schedule, in sufficient detail to demonstrate the competency of the bidder's proposals to meet the completion schedule referred to in Sub-Clause 1.3 above.

14 Documents Establishing the Bidder's Qualifications to Perform the Contract

- 14.1 The technical qualification of bidder to perform the required works is the most important criteria and each bidder shall submit the list of skilled employee in line to the sample Form provided. A minimum of one supervisor with electrical Degree/Diploma with one year experience or electrical RTI/VTI graduate with three years of field experience shall be attached with the project for each package.
- 14.2 The bidder shall provide list of tools and equipment (Form No. 6 in Section VII) related to the works including vehicles to show that the bidder has enough tools and equipment to execute the work immediately.
- i. Block and Tackle/Max Pulley- 1 set
 - ii. Wire grip come along - 1 set
 - iii. Safety equipment(boots, helmets, gloves, shoes and helmets- quantity as required during the construction period

15 Documents Establishing the Goods' and Services Conformity to the Bidding Documents

- 15.1 Not applicable in this contract.

16 Bid security

- 16.1 The Bidder shall furnish, as part of its bid, a bid security in the amount as shown below:

Package No.	Description of Package	Bid Security Amount (Nu.)	Contractor's classification
SJE01-2021	ROW clearing at Samdrup Jongkhar	27,078.00	Small
SJE02-2021	ROW clearing at Samdrupcholing	21,052.00	Small
SJE03-2021	ROW clearing at Jomotsangkha	26,719.00	Small
SJE04-2021	Plan & Maintenance Works at Samdrup Jongkhar & Samdrupcholing	20,612.00	Small
SJE05-2021	Plan & Maintenance Works at Jomotsangkha	18,839.00	Small



- 16.2 The bid security shall be denominated in the currency of the Bid. It shall be valid for 120(**One Hundred Twenty**) days (i.e. **12th March 2021 to 10th July 2021**) from the date of opening of bid and shall be in one of the following forms acceptable to the Employer:
- (a) Cash Warrant/Bank Draft/Bank Guarantee issued by a reputable bank in Bhutan acceptable to the Employer in the form provided in the Bidding Documents or another form subject to prior approval of the Employer.
 - (b) The Bank Guarantee shall be drawn in favour of Finance Officer, Finance & Accounts Division, BPC, Samdrup Jongkhar, Bhutan.
 - (c) Cash, personal cheque, etc., will not be accepted as a bid security and the bid will be treated as non-responsive and will be rejected.
- 16.3 Any Bid not secured in accordance with Sub-Clause 16.1 and 16.2 above will be treated as non-responsive and will be rejected.
- 16.4 The unsuccessful bidder's bid security will be discharged/returned as promptly as possible upon award of Contract to the successful bidder, but in any event not later than Thirty (**30**) days after the expiration of the period of bid validity.
- 16.5 The successful bidder's bid security will be discharged/returned upon furnishing the performance security and the bidder's executing the Contract.
- 16.6 The bid security may be forfeited:
- (a) if the bidder withdraws its Bid during the Period of the bid validity specified by the bidder on the Bid Form; or
 - (b) if the bidder does not accept the correction of its bid prices; or
 - (c) in the case of a successful bidder, if the bidder fails to comply with the specified time limit to:
 - (i) sign the Contract; or
 - (ii) furnish the performance security.

17 Period of Validity of Bids

- 17.1 Bids shall remain valid for Ninety (**90**) days (*From 12th March, 2021 to 10th June, 2021*) from the date of opening of bids.
- 17.2 Notwithstanding Sub-Clause 17.1 above, the Employer may solicit bidder's consent to an extension of the period of bid validity. The request and the responses there to shall be made in writing or by fax. If the bidder agrees to the extension request, the validity of the bid security provided under Clause 16 shall also be suitably extended. A bidder may refuse the request without forfeiting its bid security. A bidder granting the request will not be required or permitted to modify its Bid.



18 Alternative Bids

18.1 Not applicable in this contract.

19 Format and Signing of Bid

19.1 The Original Bid Form and accompanying documents (as specified in Clause 10), clearly marked "**Original Bid**", plus "**One(1) copy**" must be received by the Employer at the date, time and place specified pursuant to Clause 20 and 21. In the event of any discrepancy between the original and the copies, the original will govern.

19.2 The original and the copies of the bid shall be typed or written in indelible ink and shall be signed by the bidder or persons duly authorized to sign on behalf of the bidder. Such authorization shall be by a written power-of-attorney accompanying the Bid. If the Bid is not accompanied by the written power of attorney, the bidder will be treated as non-responsive and the bid will be rejected All pages of the Bid, except for un-amended printed literature, shall be initialed by the person or persons signing the Bid. The name and position held by each person signing must be typed or printed below the signature.

19.3 The Bid shall contain no interlineations, erasures or overwriting except as necessary to correct errors made by the bidder, in which case such corrections shall be initialed by the person or persons signing the Bid.

D. Submission of Bids

20 Sealing and Marking of Bids

20.1 The bidder shall seal the original and each copy of the Bid in an inner and an outer envelope, duly marking the envelopes as "**Original**" and "**Copy**". The outer envelope shall be marked "**Confidential**"

20.2 The inner and outer envelopes shall:

- a. be addressed to the Employer at the following address:

**Divisional Manager,
Electricity Services Division,
Bhutan Power Corporation Limited,
Samdrup Jongkhar: Bhutan.
Telephone No. : +975-07-251135
Email : esdsjongkhar@bpc.bt**

- b. bear the following identification:

- **Bid for Labour contract on Plan and O&M Works under ESD Samdrup Jongkhar**
- **Bid Reference No. BPC/ESD/SJ/Tech-11/2021/08 dated 5th February 2021**
- **DO NOT OPEN BEFORE 1430 Hours on 12th March 2021**



In addition to the information required in Sub-Clause (a) and (b) above, the inner envelope indicate the name and address of the bidder to enable the Bid to be returned unopened in case it is declared "Late " pursuant to Clause 23.

- 20.3 If the outer envelope is not sealed and marked as required by Sub-Clause 20.2, the Employer will assume no responsibility for the bid misplacement or premature opening.

21 Deadline for Submission of Bids

- 21.1 The original Bid, together with the required copies, must be received by the Employer at the address specified in Sub-Clause 20.2 no later than **1200 Hours on 12th March 2021.**
- 21.2 The Employer may, at its discretion, extend the deadline for the submission of Bids by amending the Bid Documents in accordance with Clause 7, in which case all rights and obligations of the Employer and the bidders previously subject to the deadline will thereafter be subject to the deadline as extended.
- 21.3 The Bidder's representative attending the bid opening shall have an Authorization Letter from the Bidder, without which the representative may not be permitted to attend the public Bid opening.

22 One Bid per Bidder

- 22.1 Each bidder shall submit only one Bid. A bidder who submits or participates in more than one Bid will be disqualified.

23 Late Bids

- 23.1 Any Bid received by the Employer after the deadline for submission of Bids prescribed by the Employer, pursuant to Clause 21, will be declared "**Late**" and rejected and returned unopened to the bidder.

24 Modification and Withdrawal of Bids

- 24.1 The bidder may notify or withdraw its Bid after the Bid's submission, provided that written notice of the modification or withdrawal is received by the Employer prior to the deadline prescribed for submission of Bids.
- 24.2 The bidder's modification or withdrawal notice shall be prepared, sealed, marked and dispatched in accordance with provisions of Clause 20. A withdrawal notice may also be sent by fax but must be followed by signed confirmation copy.
- 24.3 No Bid may be modified subsequent to the deadline for submission of Bids.
- 24.4 No Bid may be withdrawn in the interval between the deadline for submission of Bids and the expiration of the period of bid validity specified by the bidder on the Bid Form.



E. Bid Opening and Evaluation

25 Opening of Bids by Employer

- 25.1 The Employer will open Bids, including modifications made pursuant to clause 24 in the presence of bidder's representatives who choose to attend, at **1430 Hours on 12th March 2021** in the **Conference Hall, Electricity Services Division, Bhutan Power Corporation Limited, Samdrup Jongkhar**. The bidder's representatives who are present shall sign a register evidencing their attendance.
- 25.2 Envelopes marked "**WITHDRAWAL**" shall be opened and read out first. Bids for which an acceptable notice of withdrawal has been submitted pursuant to clause 23 shall not be open but return to the bidder.
- 25.3 The Bidders' names, prices of bids, all discounts offered, modifications and bid withdrawals, and the presence or absence of the requisite bid security, and such other details as the Employer, at its discretion, may consider appropriate will be announced and recorded at the time of opening. Any bid Price, or discount which is not read out and recorded at bid opening will not be taken into account in bid evaluation. Bids shall be rejected only if the bid security is not in accordance with clause 16.
- 25.4 The Bidder's representative attending the Bid opening shall have an Authorization letter from the Bidder without which the representative may not be permitted to attend the Bid Opening.
- 25.5 The Bidder's representative shall sign on the attendance sheet evidencing presence at the time of public opening of the Bids.

26 Process to be Confidential

- 26.1 Information relating to the examination, clarification, evaluation and comparison of Bids and recommendations for the award of a contract shall not be disclosed to bidders or any other persons not officially concerned with such process. Any effort by a bidder to influence the Employer's processing of Bids or award decision may result in the rejection of the bidder's Bid.

27 Clarification of Bids

- 27.1 To assist in the examination, evaluation and comparison of Bids, the Employer may, at its discretion, ask the bidder for a clarification of its Bid. All requests for clarification and the responses shall be in writing, and no change in the price or substance of the Bid shall be sought, offered or permitted except as required to confirm the correction of the arithmetic errors discovered by the Employer in the evaluation of the Bids in accordance with Clause 28.4.



28 Preliminary Examination of Bids

The Employer will examine the Bids to determine whether they are complete, whether any computational errors have been made, whether required sureties have been furnished, whether the documents have been properly signed, and whether the bids are generally in order.

- 28.1 Prior to the detailed evaluation, pursuant to Clause 30, the Employer will determine the substantial responsiveness of each Bid to the Bidding Documents. A substantially responsive Bid is one which conforms to all the terms and conditions of the Bidding Documents without material deviation or reservation. A material deviation or reservation is one;
- (i) which affects in any substantial way the scope, quality, completion schedule or performance of the Works;
 - (ii) which limits in any substantial way and is inconsistent with the provision of the bidding documents, the Employer's rights or the bidder's obligations under the Contract; or
 - (iii) whose rectification would affect unfairly the competitive position of other bidders presenting substantially responsive bids.
- 28.2 A Bid determined as not substantially responsive will be rejected by the Employer and may not subsequently be made responsive by the bidder by correction of the non-conformity.
- 28.3 Arithmetical errors will be rectified on the following bases;
- (i) If there is a discrepancy between the unit price and the total price per item that is obtained by multiplying the unit price and the quantity, the unit price shall prevail and the total price per item will be corrected.
 - (ii) If there is a discrepancy between the Total Amount and the sum of the total price per item, the sum of the total price per item shall prevail and the Total Amount will be corrected.
- 28.4 The amount stated in the Form of Bid will be adjusted by the Employer in accordance with the above procedure for the corrections of errors and, shall be considered as binding upon the bidder. If the bidder does not accept the corrected amount to bid, its bid will be rejected, and the bid security will be forfeited.

29 Conversion to Ngultrum

- 29.1 Not Applicable.

30 Evaluation and Comparison of Bids

- 30.1 The Employer will evaluate and compare only the bids determined to be substantially responsive in accordance with Clause 28.



- 30.2 In evaluating the bids, the Employer will determine for each bid the evaluated bid price by adjusting the bid price as follows:
- (a) making any correction for errors pursuant to Clause 28;
 - (b) applying any discounts offered by the bidder for the award;
- 30.3 The Employer reserves the right to accept or reject any variation, deviation or alternative offer. Variation, deviation, alternative offers and other factors which are in excess of the requirements of the bidding documents or otherwise result in the accrual of unsolicited benefits to the Employer shall not be taken into account in bid evaluation.
- 30.4 The estimated effect of the price adjustment provision of the Condition of Contract, applied over the period of execution of the Contract, shall not be taken into account in bid evaluation.
- 30.5 When the prices in the particular bid appear abnormally low (below 10% of the analyzed Market Value) or the bid appears to be seriously unbalanced as determined, the Employer shall seek written explanations from the bidders submitting the low or seriously imbalanced bid and shall request the bidder ab analysis of rates of the relevant items. Based on the bidder's written explanation, decision shall be taken to reject/accept the abnormally low or seriously unbalanced bids.

When the prices in the particular bid appear abnormally high (above 10% of the analyzed Market Value), the Employer shall seek written explanations from the bidders submitting the low or seriously imbalanced bid and shall request the bidder ab analysis of rates of the relevant items. Based on the bidder's written explanation, decision shall be taken to reject/accept the abnormally high bids.

31 Contacting the Employer

- 31.1 Subject to Clause 27, no bidder shall contact the Employer on any matter relating to its bid, from the time of bid opening to the time of the Contract is awarded. Any effort by a bidder to influence the Employer in the Employer's decisions in respect of bid evaluation, bid comparison or Contract award will result in the rejection of the bidder's Bid.

32 Employer's Right to Accept Any Bid and to Reject Any or All Bids

- 32.1 The Employer reserves the right to accept or reject any Bid and to annul the bidding process and reject all Bids at any time prior to award of Contract, without thereby incurring any liability to the affected bidder or bidders or any obligation to inform the affected bidder or bidders of the grounds for the Employer's action.



F. Award of Contract

33 Award

- 33.1 The Employer will determine to its satisfaction whether the bidder selected as having the lowest-evaluated, responsive Bid is qualified to satisfactorily perform the Contract.
- 33.2 The determination will take into account the bidder's financial and technical capabilities. It will be based upon an examination of the documentary evidence of the bidder's qualifications submitted by the bidder, pursuant to Clause 14, as well as such other information as the Employer deems necessary and appropriate.
- 33.3 An affirmative determination will be a prerequisite for award of the Contract to the bidder. A negative determination will result in rejection of the bidder's Bid.
- 33.4 The Employer will award the Contract to the successful bidder whose Bid has been determined to be the Lowest-Evaluated Responsive Bid, provided further that the bidder is determined to be qualified to satisfactorily perform the Contract. In the event of a single bidder being lowest in more than one package, the employer, at the time of award at its sole discretion, may limit the number of packages to two (2) to be awarded to a single bidder, taking into consideration the logistics, its own assessment of impact on the schedule, etc..., or for any other reason whatsoever.

34 Employer's Right to Vary Quantities at Time of Award

- 34.1 The Employer reserves the right at the time of award of Contract to increase or decrease by up to twenty percent (20%) the quantity, without any change in rate or other terms and conditions.

35 Notification of Award

- 35.1 The Employer will notify the successful bidder in writing by registered letter or by fax that its bid has been accepted. This letter (hereinafter and in the Conditions of Contract called the "**Letter of Acceptance**") shall name the sum which the Employer will pay the Contractor in consideration of the execution and completion of the Works by the Contractor as prescribed by the Contract (hereinafter and in the Conditions of Contract called "The Contract Price")
- 35.2 The notification of award will constitute the formation of a contract, until the Contract has been affected pursuant to Clause 36.
- 35.3 Upon the furnishing by the successful bidder of performance security or upon signing of the Contract Agreement, whichever is earlier, the Employer will promptly notify the other bidders that their bids have been unsuccessful.



36 Signing of Contract

- 36.1 At the time of notification of award, the Employer will send the successful bidder the Contract form provided in the bidding Documents, incorporating all agreements between the parties.
- 36.2 The successful bidder shall be invited for contract signing at the venue and date specified in the Letter of Acceptance.
- 36.3 In case the successful bidder fails to sign the contract agreement within the deadline specified in the letter of acceptance, the positive difference in contract amount with the next lowest evaluated bid and his bid security shall be recovered from the successful bidder.

37 Performance Security

- 37.1 Within ten (10) days of receipt of notification of the award from the employer, the successful bidder shall furnish the performance security in an amount of ten percent (10%) of the contract price, in accordance with the Conditions of Contract, in the Performance Security Form provided in the Bidding Documents or another forms acceptable to the Employer.
- 37.2 Failure of the successful bidder to comply with the requirements of Clause 36 or 37.1 above shall constitute sufficient grounds for the annulment of the award and forfeiture of the bid security.

38 Corrupt or Fraudulent Practices

- 38.1 The BPC requires that bidders observe the highest standard of ethics during execution of contracts. In pursuance of this policy, the BPC:
- (a) defines, for the purposes of this provision, the terms set forth below as follows:
 - (i) “corrupt practice” means the offering, giving, receiving, or soliciting, directly or indirectly, anything of value to influence improperly the action of another party;
 - (ii) “fraudulent practice” means any act or omission, including a misrepresentation, that knowingly or recklessly misleads, or attempts to mislead, a party to obtain a financial or other benefit or to avoid an obligation;
 - (iii) “coercive practice” means impairing or harming, or threatening to impair or harm, directly or indirectly, any party or the property of the party to influence improperly the actions of a party;
 - (iv) “collusive practice” means an arrangement between two or more parties designed to achieve an improper purpose, including influencing improperly the actions of another party.
 - (v) “Obstructive practice is



- (i) deliberately destroying, falsifying, altering or concealing of evidence material to the investigation of making false statements to investigators in order to materially impede any investigation into allegations of corrupt, fraudulent, coercive or collusion practice; and/or threatening, harassing or intimidating any party to prevent it from disclosing its knowledge of matters relevant to the investigation or pursuing the investigation; or
 - (ii) acts intended to materially impede the exercise of the inspection and audit rights of the Employer or organization or person appointed by the Employer and/or relevant RGoB agency.
- (b) will reject a proposal for award if it determines that the bidder recommended for award has, directly or through an agent, engaged in corrupt, fraudulent, collusive, or coercive practices in competing for the contract; and
 - (c) Will declare a firm ineligible, either indefinitely or for a stated period of time, to be awarded a contract if at any time determines that the firm has engaged in corrupt or fraudulent practices in competing for, or in executing.

39 Labour

39.1 The bidder shall commit that no child labor shall be engaged in the construction works.

40 Equal Pay

40.1 The men and women shall be paid equal for work of equal value.



Section III

CONDITIONS OF CONTRACT



TABLE OF CONTENTS

Section III Conditions of Contract

ARTICLE I	GENERAL PROVISIONS	1
A.	Definitions.....	1
B.	Language and Enforcement of Contract	2
C.	Amendments	2
D.	Settlement of Disputes	2
ARTICLE II	EMPLOYER’S AND CONTRACTOR’S OBLIGATIONS	3
E.	Employer’s General Obligations	3
1.	Payment of the Contract Price.....	3
2.	Measures for Commencement of Works.....	3
F.	Contractor’s General Obligations	3
4.	Execution of the Works.....	3
5.	Early Warning	4
6.	Performance Security	4
7.	Compliance with Laws, Rules and Regulations.....	5
8.	Representation against Material Favors	5
9.	Taxation.....	5
ARTICLE III	CONDITIONS FOR EXECUTION OF THE WORKS	5
1.	Commencement Date	5
2.	Time for Completion.....	5
3.	Extension of Time for Completion	6
4.	Sub-contracting of the Work	6
5.	Work Program	6
6.	Transportation of Materials.....	6
7.	Insurance	7
8.	Contractor’s Superintendence	7
9.	Engineer at Liberty to Object.....	7
10.	Setting Out	8
11.	Safety of Operations and Protection of Environment	8
12.	Provision of Competent Personnel.....	9
13.	Compliance with Standards.....	9
14.	Responsibility to Rectify Loss or Damage.....	9
15.	Examination of Work.....	9
16.	Monitoring of Work Progress	10
17.	Variation Orders.....	10
18.	Instructions for Variations.....	11
19.	Measurement of works	11
20.	Guarantee of Works after Completion Date.....	11
21.	Indemnity for Infringement of Property Rights	12
22.	Storage of Plant and Materials	12
23.	Facilities for Other Contractors.....	13
24.	Unforeseen Obstacles.....	13
25.	Discoveries	13
26.	Outbreak of Hostilities	13
27.	Suspension of work	14
28.	Liquidated Damages.....	14

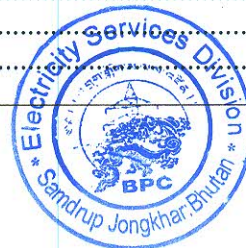

29.	Termination of Contract by Employer	14
30.	Corrupt or Fraudulent Practices:	15
31.	Payment upon Termination	15
32.	Take Over of the Works by the Employer	15
33.	Termination of Contract by Contractor	16
34.	Termination without Prejudice to Other Rights	16
1.	Cash Flow Estimates	16
2.	Advance Payment.....	16
3.	Retention Money	17
4.	Material at Site	Error! Bookmark not defined.
5.	Additional Claims	17
6.	Price Adjustment.....	17
7.	Terms of Payments.....	17
ARTICLE V COMPLETION OF THE WORKS.....		18
1.	Taking – Over Certificate.....	18
2.	Statement of Completion.....	18
3.	Contractor’s Liability	18



Section III
Conditions of Contract

ARTICLE I GENERAL PROVISIONS

A. Definitions

The following words shall be construed in accordance with the meanings assigned to them, except when a different meaning is clearly intended:

- (a) **Contract** - The signed Agreement entered into between the Employer and the Contractor is deemed to include the following:
 - 1) Invitation for Bid;
 - 2) Instructions to Bidders;
 - 3) Letter of Acceptance;
 - 4) Conditions of Contract;
 - 5) Technical Specifications & Drawings;
 - 6) Price Schedule and Sample Bill of Quantities; and
 - 7) Bid Form
 - 8) Schedule of Supplementary Information
 - 9) Such further documents as may be expressly incorporated in the Letter of Acceptance.
- (b) **Employer** - The party who employs the contractor to carry out the works or his duly authorized representative who can act on his behalf in supervising the implementation of the contract.
- (c) **Engineer** - Same as Employer.
- (d) **Contractor** - The party (a person or corporate body) who is employed by the Employer to carry out the works.
- (e) **Parties** - Refer to both Employer and Contractor.
- (f) **Works** - What the Employer requires the Contractor to do under the Contract, which may involve the use of labour, process technology, equipment, materials and suppliers.
- (g) **Plant** - Means machinery, apparatus, or instrument intended to form part of the works.
- (h) **Specifications** - Means the specifications of the works included in the Contract and any modification or addition made or approved by the Employer.
- (i) **Contract Price** – Price stated in the letter of Acceptance.
- (j) **Priced Bill of Quantities** - The quantities of works to be done together with their corresponding unit prices. Includes also the kind of labour to be employed and their day/hour rates.



- (k) **Drawings** - Include drawings, calculation, samples, patterns, models, manuals and other technical information provided by the Employer to the Contractor under the Contract for the execution of the Works.
- (l) **Unit Rate** - The price for a given measurement of Works or materials or labour used in the Works.
- (m) **Sub-Contract** - Is a person or corporate body who has a contract with the Contractor to carry out a part of the Work under the Contract.
- (n) **Commencement Date** - The date indicated in the Notice to Proceed as the date for commencement of Work.
- (o) **Completion Date** - Is the date stated in the Taking-Over Certificate that the Works were substantially completed on this date in accordance with the Contract.
- (p) **Taking-Over Certificate** - Is the certificate issued by the Employer in accordance with the provisions of the Clause 1, Article V, when the whole of the Works was completed or for any part of the works at different Dzongkhag that has been taken over by the Client.
- (q) **Variation Order** - An order issued by the Employer which involves changing any aspect of the Works.
- (r) **Defect** - Any part of the Works not executed and completed in accordance with the provisions of the Contract.
- (s) **Site** - Means the places provided by the Employer where the Works are to be executed and any other places as may be specifically designated in the Contract as forming part of the site.

B. Language and Enforcement of Contract

The Contract is executed in English language. Enforcement of the contract will be in accordance with Bhutan laws and any dispute not settled by arbitration shall be brought to a Bhutan court having jurisdiction thereof.

C Amendments

The contract shall be amended only by written agreement between the Parties, except in such cases where the Employer may, under the provisions of the Contract, issue written instructions which shall be accepted by the Contractor.

D. Settlement of Disputes

Disputes arising from the implementation of the provisions of the contract shall be settled first by negotiations between the Parties in order to arrive at an amicable settlement. If negotiations fail, the matter will be settled by arbitration, whereby each of the parties will be entitled to appoint one arbitrator, and a third one to be appointed by mutual agreement to the parties. If either the Employer or Contractor fails to appoint a representative or if both of them cannot agree on the appointment



of a third member within 30 days from the date of agreement to refer the matter for arbitration, then the case will be referred to the concerned Dzongkhag Court for adjudication.

ARTICLE II EMPLOYER'S AND CONTRACTOR'S OBLIGATIONS

E. Employer's General Obligations

1. Payment of the Contract Price

The Employer shall pay the Contractor the contract Price in Ngultrum as stipulated in the contract. Payment(s) shall be made in accordance with the terms of payment and it is the Employer's obligation to ensure that funds are released on time and are made available as needed. The Employer must also ensure that issuance of certifications, authorizations, or pre-audit procedures are not unnecessarily delayed and that no undue inconvenience is suffered by the Contractor in obtaining payments.

2. Measures for Commencement of Works

The Employer shall take all the steps necessary to enable the Contractor to commence work in accordance with the Commencement Date. These include giving the Contractor possession of the site of work and access thereto, acquisition of rights-of-way if needed, provision of data on hydrological and sub-surface conditions, drawings and specifications, supply of equipment, materials or supplies if to be provided by the Employer, and appointment of the Employer's representative who will act as the Engineer on behalf of the Employer.

3. Approvals and Authorizations

The employer shall not unnecessarily withhold or delay giving any approval, authorization, instructions or notices as may be required by him under the provisions of the contract. Any issue, problem, or matter submitted to him for consideration or decision must be addressed promptly and decisively.

F. Contractor's General Obligations

4. Execution of the Works

The contractor shall execute and complete the Works and remedy any defects therein to the satisfaction of the Employer in accordance with the provisions of the Contract. He shall provide all the technical expertise, labour, materials, machinery and equipment, plant and temporary facilities necessary for the execution and completion of the Works in accordance with the drawings, specifications, and instructions provided by the Employer under the terms of the Contract.

The Contractor shall, with due care and diligence, design (to the extent provided for by the Contract), execute and complete the Works and remedy any defects therein in accordance with the provisions of the Contract. The Contractor shall provide all superintendence, labour, materials, Plant, Contractor's Equipments and all other things, whether of a temporary or permanent nature, required in and for such design, execution, completion and remedying of any defects, so far as the

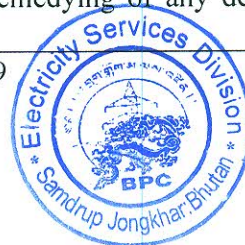

necessity for providing the same is specified in or is reasonably to be inferred from the Contract.

The Contractor shall give prompt notice to the Engineer, with a copy to the Employer, of any error, omission, fault or other defect in the design of or executing the work.

5. Early Warning

The Contractor shall warn the Employer at the earliest opportunity of specific likely future events or circumstances which may adversely affect the quality of the works, increase the Contract Price or delay the Intended Completion Date. The Employer may require the Contractor to provide an estimate of the expected effect of the future event or circumstance on the Contract Price and Intended Completion Date. The estimate shall be provided by the Contractor as soon as reasonably possible.

The Contractor shall cooperate with the Employer in making and considering proposals for how the effect of such an event or circumstance can be avoided or reduced by anyone involved in the Works and in carrying out any resulting instruction of the Employer.

6. Performance Security

On issuance of the Letter of Acceptance, the Contractor shall submit a performance security in favour of the Employer in the amount equivalent to **Ten percent (10%) of the contract price** to guarantee the faithful compliance of his obligations under the contract at the time of signing of the Contract Agreement. He shall provide such security in the form of a Bank Guarantee or irrevocable letter of credit acceptable to the Employer, issued by a bank in Bhutan. **The performance security shall be valid until the date of issue of the Taking over Certificate.** The cost of complying with the requirements of this clause shall be borne by the contractor.

The Employer shall not make a claim under the Performance Security, except for amounts to which the Employer is entitled under the Contract in the event of:

- (a) Failure by the contractor to extend the validity of the Performance Security as described in the preceding paragraph, in which the Employer may claim the full amount of the Performance Security;
- (b) Failure by the Contractor to pay the Employer an amount due, as either agreed by the Contractor or Clause 31 (Payment upon Termination) within forty two days after this agreement or determination; or
- (c) Circumstances which entitle the Employer to terminate the contract upon Clause 29 (Termination by the Employer), irrespective of whether notice of termination has given.



7. Compliance with Laws, Rules and Regulations

The Contractor shall, in the execution of the works, comply with all existing applicable laws, rules and regulations, and shall obtain the necessary permits, pay the required fees and taxes, and indemnify the Employer against any claim or liability arising from the violation of any law, rule or regulation.

8. Representation against Material Favors

The Contractor declares that it has not given, nor promised to give; any money, gift or material favor or consideration to any government official, employee or any other bidder to secure the contract and that contrary action shall be sufficient ground for revocation of cancellation of the contract.

9. Taxation

The prices bid by the Contractor shall include all customs duties, import duties, business taxes, income and other taxes that may be levied in accordance to the laws and regulations. Nothing in the contract shall relieve the Contractor from his responsibility to pay any tax that may be levied by the Government.

ARTICLE III CONDITIONS FOR EXECUTION OF THE WORKS

10. Commencement Date

The employer shall issue a Notice to Proceed, which will be the basis for commencement of work by the contractor. The Contractor should start work not later than the date indicated in the Notice to Proceed. For justifiable reasons, the Employer and Contractor may subsequently agree on another commencement date.

11. Time for Completion

The Employer shall issue notice to proceed, which shall be the basis for commencement of work by the contractor. The contractor should start work not later than the date indicated in the notice to proceed. The contractor shall begin the Works on the Start Date and shall perform and complete the Works in accordance with the program submitted by him, as updated with the approval of the Employer, by the intended completion date as below:

Sl.No	Package No.	Description of Package	Duration(Months)
1	SJE01-2021	ROW clearing at Samdrup Jongkhar	7 months
2	SJE02-2021	ROW clearing at Samdrupcholing	7 months
3	SJE03-2021	ROW clearing at Jomotsangkha	7 months
4	SJE04-2021	Plan & Maintenance Works at Samdrup Jongkhar & Samdrupcholing	7 months
5	SJE05-2021	Plan & Maintenance Works at Jomotsangkha	7 months

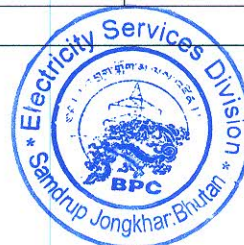

If the works are to be done by sections or in part thereof, completion of each section will be in accordance with the schedules of the completion of work submitted to and agreed by the Employer .

12. Extension of Time for Completion

An extension of the time for Completion may be allowed by the Employer for the following reasons:

- (a) additional work has to be done;
- (b) adverse climate conditions or other natural calamities have caused work stoppages;
- (c) delay or impediment on the part of the Employer; and
- (d) there are unusual circumstances that have occurred which are not directly attributable to the Contractor.
- (e) The delay caused by force majeure, including but not limited to war, riot, civil insurrection, strike or lockout by persons other than the contractor's personnel, fire, floods, epidemics, earthquakes, quarantine restrictions and freight embargoes, such delay may be excused and the period of such delay may be added to the time of performance of obligation delayed

The Contractor must give notice of any event causing a delay within twenty one (21) days of such occurrence and the Employer must within reasonable time decide on the extended date for completion. The contractor shall extend the period of validity of the Performance Security accordingly.

13. Sub-contracting of the Work

The Contractor shall not sub-contract the work or any part of the work under any circumstances. Sub-contracting of works shall lead to termination of the contract and will lead to the forfeiture of performance security deposit.

14. Work Program

The Contractor shall prepare the Work Program for the execution of the works, if advisable, with the use of spread sheet or any other networks or equivalent. One original and two copies of such diagram must be provided to the Employer not later than twenty-one (21) days after the commencement Date. The work must cover all the activities for which the contractor is responsible and must ensure that the resource required for the execution of each activity are or will be available and taken into account in setting activity duration.

15. Transportation of Materials

Materials required for the execution of the Contract are to be transported to the work sites for all Packages by the Contractor at his own arrangements from the **Stores Unit, ESD, Samdrup Jongkhar**

The contractor shall transport the materials to the sites in such a manner that materials required at the earliest will be first transported.



16. Insurance

The contractor shall obtain the following insurance coverage:

- (a) For the works (including plants and materials incorporated therein) and Contractor's equipment against loss or damage;
- (b) Against liability for accidental death or injury of any person, or loss or damage to any property arising out of the performance under the Contract. The Loss or damage of any material arising out of the performance under the contract shall be made good;
- (c) Against liability arising from accident suffered by the Contractor's workers while performing their work in accordance with Government rules and regulations. The insurance coverage shall be in such forms and amount as may be considered sufficient for the risk or liability insured against, and must be in force until the acceptance of the works; and
- (d) The Contractor shall avail full road accident insurance of goods during transportation from stores to work sites. The insurance policy should protect the goods during the vehicle accident viz. vehicle off road, head on collision, etc.

The Contractor shall assume full responsibility for the care and protection of the works, materials and plants from the Commencement Date to the date of acceptance of the whole of the Works, or of any section thereof incase of partial completion. Any loss or damage of the works occurring during this period shall be from the contractor's account. However, if the loss or damage is caused by Force Majeure, including war, civil insurrection, fires, floods, epidemics and earthquakes, the cost of restitution therefore may be considered as an addition to the Contract Price to the extent that it is not recoverable from the proceeds of any insurance coverage.

17. Contractor's Superintendence

The Contractor shall provide all necessary superintendence during the execution of the Works and as long thereafter as the Engineer may consider necessary for the proper fulfilling of the Contractor's obligations under the Contract. The Contractor, or a competent authorized representative approved of by the Engineer, which approval may at any time be withdrawn, shall give his whole time to the superintendence of the Works. Such authorized representative shall receive, on behalf of the Contractor, instructions from the Engineer. If approval of the representative is withdrawn by the Engineer, the Contractor shall, as soon as is practicable, having regard to the requirement of replacing him as hereinafter mentioned, after receiving notice of such withdrawal, remove the representative from the Works and shall not hereafter employ him again on the Works in any capacity and shall replace him by another representative approved by the Engineer.

18. Engineer at Liberty to Object

The Engineer shall be at liberty to object to and require the Contractor to remove forthwith from the Works any person provided by the Contractor who, in the



opinion of the Engineer, misconducts himself, or is incompetent or negligent in the proper performance of his duties, or whose presence on Site is otherwise considered by the Engineer to be undesirable, and such person shall not be again allowed upon the Works without the consent of the Engineer. Any person so removed from the Works shall be replaced as soon as possible.

19. Setting Out

The Contractor shall be responsible for setting out the works and for ensuring the correctness of the positions, levels, dimensions and alignment of the works. The route alignment, identification of locations for the construction of substations and pole fixing will be conducted by the Contractor in the presence of the representative engineer from the Employer. All the above settings have to be approved by the Site Engineer of the Employer prior to the commencement of works. All the measurements will be taken by the Site Engineer only for the works approved by the Employer. At any time during the execution of the works, the Contractor shall correct any error at his own expense when required to do so by the Employer. Boreholes, exploratory excavations or soil testing may be done if instructed by the Employer. In case, costs of boreholes or explanatory excavations or soil testing are not included in the Contract Price, the cost shall be borne by the Employer.

20. Safety of Operations and Protection of Environment

The Contractor shall assume full responsibility for the adequacy and safety of site operations and the methods of construction and he shall adopt measures to prevent injuries to persons or damage to properties of utilities. The Contractor shall hold the Employer harmless from any liability for loss or damage resulting from his failures to take necessary precautions. The Contractor shall avoid undue interference with private business, public travel, or with the work of other contractors. The Contractor shall take steps to protect the environment and to minimize noise, pollution or other undesirable effects resulting from his method of operation.

The Contractor shall, throughout the execution and completion of the Works and the remedying of any defects therein:

- (a) have full regard for the safety of all persons entitled to be upon the Site and keep the Sites (so far as the same is under his control) in an orderly state appropriate to the avoidance of danger to such persons;
- (b) provide and maintain at his own cost all lights, guards, fencing, warning signs and watching, when and where necessary or required by the Engineer or by any duly constituted authority, for the protection of the works or for the safety and convenience of the public or other; and
- (c) take all reasonable steps to protect the environment on and off the Site and to avoid damage or nuisance to persons or to property of the public or other resulting from pollution, noise or other causes arising as a consequence of his method of operation.



21. Provision of Competent Personnel

The Contractor shall provide adequate qualified technical personnel to supervise the Works and such skilled and semi-skilled labour as necessary to complete the Works within the time specified. He shall, subject to the approval of the Employer, appoint a competent authorized representative who will act on his behalf in receiving instructions from the Employer and in supervising the execution of the works.

22. Compliance with Standards

The Contractor shall ensure that the quality of the materials, plants and workmanship meet all standards as specified in the Contract. Whenever a specific standard is mentioned in the specifications, it is intended only as a reference and equivalent or superior standards are equally acceptable subject to prior approval of the Employer. The execution procedure should be strictly adhered as specified in Section-IV, Technical Specification.

23. Responsibility to Rectify Loss or Damage

If any loss or damage happens to the Works, or any part thereof, materials or Plant for incorporation therein, during the period for which the Contractor is responsible for the care thereof, from any cause whatsoever, the Contractor shall, at his own cost, rectify such loss or damage so that the Permanent Works conform in every respect with the provisions of the Contract to the satisfaction of the Employer. The Contractor shall also be liable for any loss or damage to the Works occasioned by him in the course of any operations carried out by him for the purpose of complying with his obligations.

24. Examination of Work

The Employer shall have the right to conduct whatever tests or inspections it may consider necessary to determine whether or not the work is being executed in accordance with the provisions of the contract. Such right may include testing of samples of materials used in the works, examination of the quality of the workmanship and conformity of the works to drawings and specifications.

The Contractors shall provide such facilities, apparatus and instruments, sample of materials, manpower and other forms of assistance that are needed in conducting the tests or inspections. Tests may be done in the workshops or at the site of operations and the date and time for carrying them out should be agreed upon between the Employer and the Contractor.

If the Employer determines, after inspections, that materials used or the work done are defective in any respects, he may reject the said materials or Works and demand that the Contractor rectifies the defects by replacing the materials or by re-executing the works. If the Contractor fails within a reasonable period of time to such action as instructed by the Employer, the Employer shall have the right to employ other persons to carry out the same and the cost shall be borne by the Contractor.



25. Monitoring of Work Progress

At such time as will be agreed upon between the Employer and the Contractor, a periodic review meeting of the progress made will be undertaken. Based on the actual progress achieved, if necessary, an up-date of the work program for the execution of the remaining works will be prepared by the Contractor taking into account the effect of variations and additional works to be undertaken. Failure to submit an up-dated work Program will entitle the Employer to withhold payment of the next amount due as progress payment.

If delay is being encountered in the execution of the Works as determined against the approved Work program, the Employer and the Contractor shall, after examining the causes of the delay, agree on appropriate measures to be taken in order to make up the delay and to avoid further work slippages.

The Employer's acceptance of any revised Work Program shall not relieve the Contractor of his obligations under the contract.

26. Variation Orders

The Employer may, at any time during the progress of the Works, make variations in the form, quality or quantity of the works. Such variations may consist of the following:

- (a) Increase or decrease in the quantity of work to be done as indicated in the Contract;
- (b) Omission or insertion of any item of work;
- (c) Change in the level, lines, positions and dimensions of any part of the works;
- (d) Change in the character, quality, or kind of any work;
- (e) Additional work of any kind; and
- (f) Change in the sequence or timing of construction activities.

The Employer can order a variation by issuing a written instruction to the Contractor. A variation made shall not, in any way, vitiate or invalidate the Contract.

All variations, except under item (a) above, shall be valued at the rate and prices set out in the Contract ("Bill of Quantities"). If the Contract does not contain any rate(s) applicable to the variations, suitable rates or prices will be agreed upon between the Employer and the Contractor. In the event of disagreement between the parties, the Employer shall fix the rates as may consider fair and appropriate and shall notify the contractor.

The Contractor shall not make any such variation without an instruction of the Engineer.



For variations under item (a) increase or decrease in the quantities of work, variations shall be valued at the rates and prices set out in the Contract, if the variation in quantity is within the limit of (+/-20%) for each item of work. If the final quantity of the work executed varies from the quantity in the Bill of Quantities of the Contract for that item by more than +/-20%, and the value of this variation exceeds one percent (1%) of the Original Contract Prices stated in the Letter of Acceptance, the excess quantity over the limit shall be paid to the Contractor at a suitable rate or price agreed upon between the Employer and the Contractor. In the event of disagreement between the parties, the Employer shall fix the rates and prices as may be considered fair and appropriate and shall notify the Contractor. If the value of this variation is less than one percent (1%) of the Original Contract Price, the excess quantity shall be paid to the Contractor at the unit rate or price set out in the Contract. The value of all variations shall be taken into account in determining the final Contract Price.

Note:

It may however, be noted that even in the event of any variation beyond this limit, payments are made strictly based on the actual volume of work executed and at the same rate or price set out in the Contract.

27. Instructions for Variations

The Contractor shall not make any such variation without an instruction of the Engineer. Provided that no instruction shall be required for increase or decrease in the quantity of any work where such increase or decrease is not the result of an instruction given under this Clause, but is the result of the quantities exceeding or being less than those stated in the Bill of Quantity.

28. Measurement of works

The quantities set out in the Bill of Quantities should be considered as estimates and may not necessarily be the actual and correct quantities of work to be performed under the Contract.

The Contractor shall be responsible for the measurements of Works and the preparation of its bills. The measurement of works shall be carried out jointly by the Employer's representative and the contractor. The Employer's Representative shall record the measurements in the measurement book in accordance with the Financial Manual. The record entered in the measurement book shall be signed by the Employer's representative and countersigned by the contractor. The works shall be measured net except otherwise provided for in the specifications.

No part of the Works shall be covered up or put out of view without the approval of the Employer's representatives and the Contractor afford full opportunity for the Employer's representative to examine and measure any such part of the works which is about to be covered up or out of view. The contractor shall give due notice for examination and measurement. The Employer's representative shall, without unnecessary delay, arrange for examining and measuring such part of the works, unless he considers it unnecessary and advises the Contractor accordingly.

29. Guarantee of Works after Completion Date

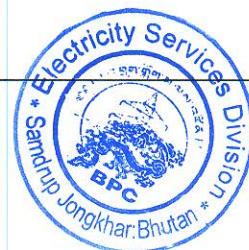

The contractor guarantees that the work performed, and the materials and equipment furnished shall be free from defects, that they comply with the prescribed specification and that they passed the required performance tests. This guarantee shall be **for a period of twelve (12) months** after the Completion of the whole Works known as defects liability period and within that period, the Contractor commits itself to repair or replace, promptly and without charge, any work, equipment and materials or part thereof which fail to meet the aforementioned guarantee.

Upon the issue of any Taking-Over Certificate, the Contractor shall clear away and remove from that part of the Site to which such taking-over Certificate relates all Contractor's Equipment, surplus material, rubbish and Temporary Works of every kind, and leave such part of the Site and Works clean and in a workmanlike condition to the satisfaction of the Engineer. Provided that the Contractor shall be entitled to retain on Site, until the end of the Defects Liability Period, such materials, Contractor's Equipment and Temporary Works as are required by him for the purpose of fulfilling his obligations during the Defects Liability Period.

30. Indemnity for Infringement of Property Rights

The Contractor shall indemnify the Employer for any claim, cost or liability on account of any infringement of any patent, trademark, trade name or any protected right in respect of equipment, materials or plants used in the Works except where such infringement results from compliance with the design or specifications provided by the Employer.

31. Storage of Plant and Materials

The Contractor shall provide adequate and safe facilities for storing Plant and materials that will be used in the execution of the works. They must be neatly piled and compactly stored in the places that provide clear access to the site and without causing any inconvenience or create any danger to the public.

Excavated materials, wreckage and waste products, shall be disposed-off quickly so as not to cause unnecessary obstruction or create sanitation/environmental problems.

The loading of materials to their trucks will also be arranged by the Contractor and will comply with the instruction issued by the Stores Officer of the Employer.

If there is any balance material or materials to be returned, ***the Contractor shall hand over the same as per Annexure I after 90% of the work Completion.*** The Contractor should meet all associated cost to this effect and the Employer shall not be responsible for any cost involved.

If the Contractor fails to return the balance materials in full set of each item, the Contractor shall pay employer's purchasing cost of the items plus 50% on the purchasing cost to the Employer. Final bills shall be released only after return of all balance materials.

Any excess materials returned by the Contractor will not be taken by the Employer and paid for. And if the contractor is not able to return the balance materials within



Sixty (60) days after physical completion and charging of the lines successfully, the Employer shall collect the balance materials at the cost and risk of the Contractor before releasing the final payment to the contractor. However, the balance materials collected by the Employer in incomplete set shall be construed as lost or unreturned whereby its associated cost shall be deducted from any money payable to the Contractor.

32. Facilities for Other Contractors

The Contractor shall, upon the instructions of the Employer, provide other contractors and workmen employed by the Employer, reasonable opportunity for carrying out the works and if required, to make available the use of roads, equipment and labour subject to additional compensation as may be determined by the Employer.

33. Unforeseen Obstacles

If during the execution of the works, the Contractor encounters physical obstructions or adverse geological or hydrological conditions on the site that could not have been reasonably foreseen, he shall give notice to the Employer, and both the Contractor and the Employer will determine:

- (a) To what extent and extension of time will be necessary, and
- (b) The amount of additional costs which have been incurred by reason of such obstructions or conditions and how, and by whom the cost will be borne.

34. Discoveries

Anything of historical or other interest or of significant value discovered on the site shall be the property of the Employer. The Contractor shall notify the employer of such discoveries and carry out in accordance with the instructions of the Employer for dealing with such discoveries.

35. Outbreak of Hostilities

If during the period when the contract is in force, which may be before or during the execution of the works, there is an outbreak of hostilities between the armed opposite forces, which may impede or render impossible the commencement, continuance or completion of works, then the parties shall agree between themselves as to what steps will be taken under the circumstances, including a deferment or temporary suspension of the works or even termination of the Contract. However, the Contractor shall, until the decision has been reached, endeavor to start or complete the execution of the works to the best of his ability in close consultation with the Employer.

In case of termination by reason of outbreak of hostilities, the Employer shall pay the Contractor whatever amounts are due for Work already performed and for such other expenditures which the Contractor has incurred in accordance with the provisions of the Contract.



36. Suspension of work

The Employer may suspend the execution of the Works or any part thereof and the Contractor shall, during such suspension, protect the Works against loss or damage due to adverse external conditions. If the suspension is not due to default or breach of Contract on the part to the Contractor, an extension of time for the completion of works will be allowed, as may be determined by the Employer. The Employer and the Contractor may also agree on the amount to be added to the Contract Price by reason of such suspension.

Should the suspension which is not caused by the default of the Contractor last for more than forty five (45) days, the Contractor may request thereafter permission to continue with the works giving his reasons thereof. If permission is not granted without justifiable reason within twenty one (21) days after permission has been requested, such denial may be treated as Employer's default and the Contractor shall be entitled to terminate his employment under the Contract.

The Contractor shall be entitled to suspend the execution of the works if the Employer fails or refuses to pay the Contractor any amount due under the Contract within sixty (60) days after the amount becomes due and payable, after prior presentation of Notice for Payment. Should the Employer pay subsequently after such suspension or reduction of Work, the Contractor shall resume normal work as soon as is reasonably possible.

37. Liquidated Damages

If the Contractor fails to complete the whole of the works, or any part thereof within the time agreed upon for completion, the Employer shall have the right to collect from the Contractor liquidated damages equivalent to **0.1 percent of the Contract Price for every Day of delay**. However, the total amount of liquidated damages shall not exceed ten percent (10%) of **the Contract Price**.

38. Termination of Contract by Employer

The Employer may terminate the Contract upon thirty (30) days notice to Contractor on the ground that:

- (a) Contractor has stopped working continuously for ten (10) days and in spite of repeated (three times) notice by Employer to start the work.
- (b) In the opinion of the Employer, in spite of repeated notice, Contractor was not able to deploy sufficient manpower at site to execute the Contract and may not be in position to complete the work as per schedule.
- (c) Continuance of the work has become impossible, or will work adversely against the Employer's interest.
- (d) The Contractor has become insolvent or financially incapable of completing the works or has assigned his assets for the benefit of his creditors.
- (e) The Contractor has violated certain important provisions to the Contract, such as Sub-Contracting of the works without the approval of the Employer in writing, failure to comply technical specifications, poor workmanship, unreasonable delay, etc., and has failed to take compensatory measures.

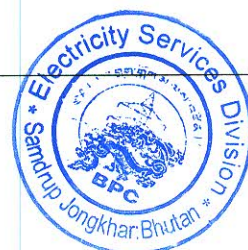

39. Corrupt or Fraudulent Practices:

If the employer determines that the contractor has engaged in corrupt, fraudulent, collusive, coercive or obstructive practices in competing for or in executing the contract, then the Employer may, after giving 14 days' notice to the contractor terminate the Contractor's employment under the contract and expel him from the site, and the contractor shall stop the work immediately, make the site safe and secure, and leave the site as soon as reasonably possible.

For the purpose of this Clause:

- (a) "Corrupt practice" is the offering, giving, receiving or soliciting, directly or indirectly, of anything of value to influence improperly the actions of another party;
- (b) "fraudulent practice" is any act or omission, including a misrepresentation, that knowingly or recklessly misleads, or attempts to mislead, a party to obtain a financial or other benefit to avoid an obligation;
- (c) "collusive practice" is an arrangement between two or more parties designed to achieve an improper purpose, including influencing improperly the actions of another party;
- (d) "coercive practice" is impairing or harming, or threatening to impair to harm, directly or indirectly, any party or the property of the party to influence improperly the actions of a party;
- (e) "Obstructive practice is
 - (i) deliberately destroying, falsifying, altering or concealing of evidence material to the investigation of making false statements to investigators in order to materially impede any investigation into allegations of corrupt, fraudulent, coercive or collusion practice; and/or threatening, harassing or intimidating any party to prevent it from disclosing its knowledge of matters relevant to the investigation or pursuing the investigation; or
 - (ii) acts intended to materially impede the exercise of the inspection and audit rights of the Employer or organization or person appointed by the Employer and/or relevant RGoB agency.

40. Payment upon Termination

If the Contract is terminated because of a fundamental breach of Contract by the Contractor and/or due to violation of any of the provisions under the Integrity Pact by the Contractor, the Project Manager shall issue a certificate for the value of work done and materials ordered less advance payments received up to the date of the issue of the certificate and less the value of work not completed.

41. Take Over of the Works by the Employer

In case of termination under Clause 29 above, the Employer will take possession of the works, materials, tools, equipment and other properties of the Contractor which have been provided in connection with the Works, and may continue and complete



the works by whatever manner or method it deems best including the employment of another contractor. The cost of completing the same shall be deducted from whatever monies are due to the Contractor had the Contract not been terminated. If the amount due to the Contractor is less than the residual cost of completion, the Contractor shall pay the difference; if the residual cost is less, the Contractor shall have no claim to the excess, except for payment for rentals for the use of the Contractor's cost of protecting and securing the Works, and less all payments received by the Contractor up to the date of the Certificate.

42. Termination of Contract by Contractor

The Contractor may terminate the Contract upon thirty (30) days notice to the Employer where;

- (a) The works have been suspended by the Employer for sixty (60) days and no permission to resume work has been granted, and
- (b) The Employer has failed to pay any substantial sums due to the Contractor under the terms of the Contract within the time specified for payment.

43. Termination without Prejudice to Other Rights

The right of either the Employer or the Contractor to terminate the Contract in accordance with the foregoing provision is without prejudice to any actions, or remedies which either party may take under the provisions of the Contract.

ARTICLE IV PAYMENT PROVISIONS

44. Cash Flow Estimates

The Contractor shall submit a quarterly cash flow estimate indicating the amount of quarterly payments expected to be made under the Contract based on the approved Work Program.

45. Advance Payment

The Contractor shall be eligible for advance payment of ten percent (10%) of the Contract Price excluding provisional sum and contingency, which can only be used to pay for equipment and other mobilization expenses required to start the works. The advance payment will be made only upon submission to the Employer of an unconditional bank guarantee in a form and by a bank acceptable to the Employer in amount equal to the advance payment. Such guarantee shall remain effective until the advance payment has been repaid fully.

The advance payment shall be repaid by the Contractor through percentage deduction from the interim progress payments and that the advance payment shall be fully repaid prior to the time when eighty percent (80%) of the Contract Price has been certified for interim progress payment. The amount of the bank guarantee may proportionately be reduced with every repayment made by the Contractor.



46. Retention Money

From each amount due for payment, the Employer will deduct ten percent (10%) thereof as Retention Money. Such deductions will be made until the completion of the Works and shall serve as a guarantee that any defects discovered during the Defects Liability Period will be corrected. Upon the expiration of the Defects Liability Period, the remaining balance to the retention money will be returned to the Contractor.

The Employer and the Contractor may agree that after the completion of the Works but during the warranty period, the Retention Money or part thereof will be returned to the Contractor and in lieu thereof, a bank guarantee may be put up by the Contractor.

47. Additional Claims

Should the Contractor have any additional claims for payment pursuant to any provision of the Contract, he shall advise the Employer about such claims, and submit to the Employer full details thereof including the basis of the claims. The Contractor shall permit the Employer to examine all records relevant to the claims.

Within thirty (30) days after receipt of the claims, the Employer shall establish the veracity and propriety of the claim and shall communicate to the Contractor his decision. The Employer may decide to pay the full amount claimed, or may opt to pay just part thereof, to the extent of what has been substantiated by the evidence submitted by the Contractor. In case of disagreement, an arbitrator(s) may be appointed by the parties to resolve any difference between them.

48. Price Adjustment

The rates and prices in the Bill of Quantity are fixed for the duration of the contract. Hence, no price adjustment shall be applicable under the contract.

49. Terms of Payments

The Contractor shall submit monthly bills/invoices for completed works. The bills/invoices must be supported by joint measurement duly signed by the Engineer of the Employer. Based on these measurements, the Employer shall then review and verify the bills/invoices submitted by the Contractor and determine how much is actually payable to the Contractor after necessary deductions. The Employer may make any correction or modification in any previous payments which has been approved by him.

The Final Payment by the Employer to the Contractor in respect of the whole Works under the Contract shall be made as per Clause 2, Article V.

Payment shall be made by the Employer within sixty (60) days from receipt of statement, unless delay is encountered in the submission of supporting documents if required by the Employer.



ARTICLE V COMPLETION OF THE WORKS

50. Taking – Over Certificate

When whole of the works have been substantially completed and satisfactorily pass any tests on completion prescribed by the Contract, the Contractor may give a notice to this effect to the Employer, accompanied by a written undertaking to finish with due expedition any minor outstanding work during the Defects Liability Period. Such notice and undertaking shall be deemed to be a request by the Contractor for the Employer to issue a Taking-Over Certificate in respect of the work. **The Employer shall either issue a Taking-Over Certificate, stating the date on which the works were completed in accordance with the Contract, or give instructions in writing to the Contractor specifying all the work, including any defects in the Works affecting completion, which is required to be done before the issue of such certificate.** The contractor shall be entitled to receive such Taking-Over Certificate within 21 days of satisfactory completion of the works so specified and remedying any defects so notified.

51. Statement of Completion

After the issue of the Taking-Over Certificate in respect of the whole works and when the minor outstanding works have been completed including the final clean-up of the Site has been performed, the Contractor shall submit the Employer a Statement of Completion which shall show in detail:

- (a) The final value of the work done in accordance with the Contract, including variations.
- (b) Any further sums that are due to the Contractor and remain unpaid.

Upon receipt of such statement, the Employer shall conduct a final inspection of the Works, measure the works and within Forty five (45) days from receipt of the statement of Completion prepare a final estimate and present the same to the Contractor for his concurrence. This statement, if approved by both parties, is the Final statement and the total amount of the Final Statement represent full and final settlement of all monies due to the Contractor arising out of or in respect of the Contract.

53. Contractor's Liability

Neither the final inspection nor the preparation of the Final Statement by the Employer, nor the issuance of the Taking-Over Certificate to the Contractor, nor the payment of the amount due, nor the possession by the Employer of the Work, shall operate as a waiver of the provision of the Contract, and the Contractor shall remain liable for a period of Twelve (12) months from the date of completion, stated in the Taking-Over Certificate, for any defect or damage arising from any violation or lack of compliance with the covenants and conditions of the Contract.

Any work of reconstruction and correcting of defects must be done within thirty (30) days from receipt of advice of the existence of such defects by the Contractor.



Conditions of Contract

The cost of such works shall be for the account of the Contractor if the defect(s) were due to:

- (i) The use of materials, plant or workmanship not in accordance with the Contract;
- (ii) Fault in design for which the Contractor was responsible; and
- (iii) Failure on the part of the contractor to comply with any obligation under the contract.

Neither shall the Contractor be released of any unfulfilled obligations including, but not limited to, the payment of taxes due to him, and for unpaid claims for labour, materials and equipment used in the works.



Section IV

TECHNICAL SPECIFICATIONS



Technical Specifications

Table of Contents

1.	GENERAL.....	1
2.	CONSTRUCTION OF OVERHEAD 33 kV, 11 kV AND LOW VOLTAGE LINES.....	2
2.1	General.....	2
2.2	Distribution line voltages, locations and clearances.....	2
2.2.1	Standard voltage for distribution system:.....	2
2.2.2	Choice of route.....	2
2.2.3	Approval of Line Routes.....	3
2.2.6	Overhead Line Clearances.....	4
2.2.7	Road Crossings.....	5
2.3	Construction, Testing and Commissioning.....	5
2.3.1	Alignment of the line.....	5
2.3.2	Erection of supports.....	5
2.3.3	Erection of DP Structures for angle locations.....	6
2.3.4	Special Foundation in Unstable Soil.....	6
2.3.5	Anchoring and providing guys for supports.....	7
2.3.6	Fixing of cross arms and insulators.....	7
2.3.7	Laying of AAAC/HV ABC/LV ABC/ACSR Conductor.....	8
2.3.8	Mid span jointing of conductors.....	8
2.3.9	Sagging and Tensioning of conductors.....	9
2.3.10	Conductors Sag and Tension.....	11
2.3.11	Supports at Different Elevation.....	13
2.3.12	Good Conductor Stringing Work Practices.....	14
2.3.13	Earthing of Distribution Lines.....	15
2.3.14	Final Completion and Commissioning.....	16
3.	UNDERGROUND CABLE INSTALLATION.....	16
3.1	General Scope.....	16
3.2	Codes and Standards.....	16
3.3	Installation Work Scope.....	16
3.4	Earthing of Cables.....	23
3.5	Testing of Cables.....	24
4.	INSTALLATION OF DISTRIBUTION TRANSFORMER SUBSTATIONS.....	24
4.1	Selection of Site.....	24
4.2	Installation of PAD Mounted Distribution Transformers.....	24
4.3	Fencing Arrangement.....	25
4.4	Substation Earthing.....	25
4.5	Transportation and Handling of Transformers.....	26
4.6	Substation Structure and Earthing.....	27
4.7	Protection of distribution transformers.....	27
4.8	Installation of Distribution/Mini Pillars.....	28
4.9	Connection of Supply to Consumer's Premises.....	29
4.10	Consumer Metering.....	29
4.11	Direct Connected Metering.....	29
4.12	CT Metering.....	30
4.13	High Voltage Metering.....	300



1. General

All the works should be carried out strictly as per the Drawings, Specifications, etc. and as per the Contract document. Any modification/changes pertaining to the work should not be carried out without the prior written approval from the Employer. Any modification/changes done without the prior approval will be asked to be dismantled/demolished at the cost of the Contractor and the Employer will not be responsible for any cost whatsoever associated with the modification of works. All approval shall be in writing and no verbal approval will be entertained.

Prior to start of work, the Contractor is obliged to study the route and possible location of various poles, double pole, angle pole, transformers, etc. Any change in the route or modification should be at the approval of the Employer. The Scope of Works to be carried out under the Contract covers all the works associated with the:

- a) Construction, testing and commissioning of 33 kV (Three phase and Two Phase), 11kV (Three Phase and Two Phase) and LT lines (Three Phase and Single Phase) including line route finalization, transportation of materials from designated stores to the Work site, erection of poles, fixing of insulators, line stringing, clamping, earthing, erection of anti-climbing devices, danger plates, painting of poles, etc.
- b) Erection, testing and commissioning of distribution transformers including transportation of materials from designated Stores to sites, mounting of the transformers, distribution pillars, associated pole-top equipment like isolators, drop-out fuses, earthing work, etc.
- c) Clearing jungles/bushes, trees and removal of branches and disposal; felling of trees including cutting of trunks and branches, and removal;
- d) Materials required for the execution of the Contract shall be collected from the designated stores as specified under Article III, Clause 6 of Conditions of Contract.

The Bidder shall note that supply of sand, stone chips, cement, bricks, HT tiles, PVC tape, Ampere Tape, Welding rods, Hack saw blades, marking cloth, nuts & bolt and Aluminium lugs, paints, thinner, charcoal and salt for earthing, GI pipes & HDPE pipes (as specified in BoQ), and other miscellaneous material required for the construction work is in the Bidder's Scope. Bidder shall also note that any excess materials procured by the Bidder for the construction works will not be taken by the Employer.

The Bidder may contact the persons mentioned in Clause 3.3 of Section II- Instructions to Bidders, for detailed list of miscellaneous items required.



Technical Specifications

The work shall be carried out with full diligence and in accordance with the general guidelines listed herein. It is imperative/mandatory that the workers and the Supervisors wear safety helmet, safety belts and other kits for their own safety.

The survey work shall be carried out in close coordination with the Employer's Engineer and the line route and the pole locations, angle points, etc. finalized and approved by the Employer's Engineer. All the works associated with the erection shall be carried out under the general supervision of the Employer's Engineer/Supervisor.

2. Construction of Overhead 33 kV, 11 kV and low voltage lines

2.1 General

This section covers the procedures to be adopted during the construction of 33kV lines, 11kV lines, low voltage lines etc. Before start of construction works, the persons in charge shall familiarize with the line route and acquaint themselves with the Local Rules, so that necessary provisions there-of may be adopted.

2.2 Distribution line voltages, locations and clearances

2.2.1 Standard voltage for distribution system:

Proposed Medium Voltage (MV) construction:

- 33 kV Line (Three Phase, 3 wire & Two Phase, two wire)
- 11 kV Line (Three Phase, 3 wire & Two Phase, two wire)
- 6.6 kV Line (Three Phase, 3 Wire & Two Phase, two wire)

Proposed Low Voltage (LV) construction

- LV Line (Three phase, 4 wire, 415 Volts)
- LV Line (Single phase, 2 wire, 240 Volts)

2.2.2 Choice of route

The route selected for the proposed overhead line should be the one that will give the lowest cost over the life of the line. Route selection therefore involves consideration of a number of factors, including the cost of landowner compensation, the cost of transporting materials to the site, construction cost and the cost of ongoing maintenance requirements including vegetation control. As a general rule, following parameters should be kept in mind:

- a. The shortest route practicable.
- b. As close as possible to the road for easy maintenance and approach during construction.
- c. Route in direction of possible future load.



- d. Angle point should be less.

Where possible, line routes should avoid steep hills or valleys, swamps, lakes, thick forests, rivers or other locations where access is difficult or long spans are required. When building along a road, pole positions should not cause a traffic hazard or be in locations where there is a higher probability of vehicle impact.

The following should be avoided wherever possible:

- a) Areas likely to be used for future urban development;
- b) Routes incorporating sharp changes in line direction;
- c) Routes close to aerodromes;
- d) Religious monuments;
- e) Special trees of religious significance;
- f) School playgrounds;
- g) Cemeteries;
- h) Buildings containing explosives;
- i) Taking lines through individual/private plots/community forest; and
- j) Not considering the aesthetic of the land use.

No lines should be within 50ft distance from a National Highway.

2.2.3 Approval of Line Routes

Prior to the erection of lines along public roads, the authority responsible for the road should be contacted and approval obtained for the location of all poles, road crossings, tree cutting or trimming and guying locations. Where overhead distribution lines are to be constructed in urban areas, it will also be necessary to contact the local Town Planning Authority for approval. Where appropriate, approval should also be obtained from authorities such as the National Environment Commission, Department of Forestry, etc.

Once the line route is finalised, a detailed line survey should be undertaken and the pole locations finalized and marked. Poles should be located well clear of water and other areas of potential land subsidence. Poles for lines that cross-agricultural fields should, wherever possible, be located at bunds.

2.2.5 Tree clearances

The width for tree clearance will depend upon the voltage and the importance of the line concerned. No rigid limitations can be laid down. However, the following clearances may be adhered to, as far as possible.

Voltage	Comment
33 kV lines (Bare ACSR, 3 phase & 2 Phase)	The route should be cleared of all growth within 6 m on either side starting from the centre of the line and, in addition, of trees that could fall and contact the line.



Technical Specifications

11 kV lines (Bare ACSR, 3 phase & 2 Phase)	The route should be cleared of all growth within 4.5 m on either side starting from the center of the line and, in addition, of trees that could fall and contact the line.
33 kV Lines (Covered Conductor, 3 Phase & 2 Phase)	The route should be cleared of all growth within 4 m on either side starting from the center of the line and, in addition, of trees that could fall and contact the line.
11 kV Lines (Covered Conductor, 3 Phase & 2 Phase)	The route should be cleared of all growth within 3 m on either side starting from the center of the line and, in addition, of trees that could fall and contact the line.
All ABC	Left to the discretion of the Supervisor. Aerial bundled conductor is insulated so contact with vegetation should not cause a fault. However, the route should be cleared so the risk of trees falling across the line is minimized.

2.2.6 Overhead Line Clearances

The following minimum clearances should be maintained.

Particulars	33 kV	11 kV	6.6 kV	LV (bare conductor)	LV (ABC)
Ground clearance					
• Across street	6.1 m	6.1 m	6.1 m	5.8 m	5.5 m
• Elsewhere	5.8 m	5.8 m	5.8 m	5.5 m	4.5 m
Separation between phases					
• Horizontal	0.9 m	0.7 m	0.7 m	#	#
• Vertical	1.0 m	0.6 m	0.6 m	0.3 m	#
Clearance from buildings					
• Horizontal	1.8 m	1.2 m	1.2 m	1.2 m	#
• Vertical	3.7 m	3.7 m	3.7 m	2.5 m	#
Sectional clearance	2.8 m	2.6 m	2.6 m	#	#
Safe working clearance (minimum)	0.6 m	0.3 m	0.3 m	0.15 m	#

Notes: #: Not Applicable

The following minimum vertical separation of conductors should be maintained.

Particulars	Minimum Clearance
33 kV and 11 kV	1.2 m
33 kV and LV	1.5 m
11 kV and LV	1.2 m
33 kV or 11 kV and telephone line	1.8 m

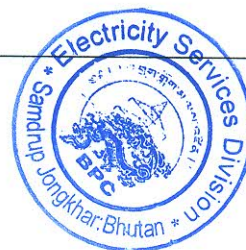

LV and telephone line	0.6 m
-----------------------	-------

2.2.7 Road Crossings

The road crossings should be as minimum as possible

2.3 Construction, Testing and Commissioning

The construction of overhead lines may be divided into the following parts:

- (i) Erection of supports.
- (ii) Providing guys to supports.
- (iii) Mounting cross-arms, pins and strain insulators.
- (iv) Stringing of line conductors.
- (v) Jointing of conductors.
- (vi) Sagging or tensioning of conductors.
- (vii) Earthing.
- (viii) Testing and commissioning.

The drawings/sketches may be referred, which give the details regarding phase to phase clearances, positioning of cross arms, pole top brackets, earth wire clamps, etc.

2.3.1 Alignment of the line

A detailed route survey for the line has to be made and approval of the alignment of the line should be obtained by the Engineer before excavation of the pits. To the extent possible, alignment of lines shall be located along or close to existing roads and tracks. During alignment, the pole locations may be marked with pegs conspicuously and shall be located with adequate distance from water bodies. Also, the poles that pass through agricultural field, to the extent possible shall be located at the bunds.

2.3.2 Erection of supports

After the final survey of the line and after marking of the pole locations with peg and approved by the Employer, excavation work has to be commenced. The pits for the supports are excavated in the direction of the line as this will facilitate the erection of support, in addition to giving greater lateral stability. The depth of the foundation to be excavated for poles shall be 1400 mm for 7.5 metre poles (LV), 1600 mm 9.0 metre (11 kV) poles and 1900mm for 10 metre (33kV) poles, while the area of the foundation will be 600x700mm.

Before the pole is put into the pit, a stone base of 100 mm thick shall be placed at the bottom of the pit. In lieu of 100 mm PCC base, base plate is being used. When the pole is erected inside the pit, wooden dead men may be utilized to facilitate lifting of the pole.

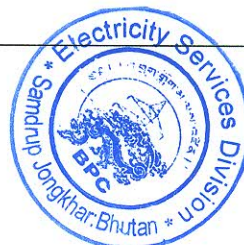

Once planted into the pit, the pole should be kept in a vertical position with the help of ropes, using them as a temporary anchor.

As the poles are being erected, say from an anchor point to the next angle point, the alignment of the poles is to be checked and set right by visual check. The verticality of the poles are to be checked with a spirit level on both transverse and longitudinal directions. In case of LV lines, the holes for fixing hook bolts are also to be checked for facing proper direction.

Once the verticality and alignment are satisfactory, the pit shall be backfilled and compacted to a distance of 450 mm below ground level. A 500 x 500 mm concrete foundation shall then be constructed around the pole and extending to 300 mm above the ground level as shown in the relevant drawings. The concrete shall be a mixture of cement, granite chips of 20/30 mm mesh and sand in the ratio of 1:2:4. The top of the foundation shall be tapered to allow water to run away from the pole.

Concrete foundations are not required for poles that are hot dip galvanised. In this case the foundation should be backfilled with excavated soil. The backfill should be progressively compacted as the foundation is filled. Do not simply refill the foundation and compact at the surface.

After the poles have been set and the excavated pit backfilled and compacted, the temporary anchors may be removed

2.3.3 Erection of DP Structures for angle locations

Generally, for angles of deviation more than 10 degrees, double pole structure shall be erected. The pits are to be excavated along the bisection of the angle of deviation.

Before the pole is put into the pit, a stone base of 100 mm thick shall be placed at the bottom of the pit. In lieu of 100 mm PCC base, base plate is being used. After erection of the poles the pits will need to be temporarily backfilled so the poles can be climbed and the horizontal bracing fitted. The structure should then be set for verticality and alignment and the supports held in position with the help of temporary rope guys.

The temporary backfilling should be removed and permanent foundations constructed by backfilling, compacting and, if necessary, concreting each pit as described in Section 2.3.2. Concrete foundations are not required if the poles are hot dipped galvanised.

Stays along the bisection of the angle of deviation as required depending on the conductor size and angle of deviation, are to be provided.

2.3.4 Special Foundation in Unstable Soil

Special care has to be taken where foundation in unstable soil is encountered.



In such locations, mass concrete foundations, extending up to the ground level, are to be adopted to avoid collapse of foundation in the unstable soil. The concrete is to be a mixture of cement, granite chips of 20/30 mesh and sand in the ratio of 1:2:4.

2.3.5 Anchoring and providing guys for supports

One or more guys will have to be provided for all supports where there is an unbalanced strain action on the support, which may result in tilting/uprooting or breaking of the support. To avoid such situation arising, guys are provided to take care of the unbalanced forces. Normally, these guys are provided to the supports at the following places: (i) Angle locations (ii) Dead end locations (iii) Tee-Off points (iv) Termination Points (v) Unstable locations and (vi) Steep gradient locations to avoid uplift on the poles.

Guy wires shall be angled at 45° from the vertical for MV lines and 30° from the vertical for low voltage lines.

Single guys shall be provided for single poles with line deviations from 5° to 10° and also for double poles with line deviations not exceeding 30°. Where the angle of deviation exceeds 30°, two guys along the resultant angle of line deviation or one guy in each direction of the line shall be provided. When two or more stays are fixed to the same support, each stay should be attached separately to the pole.

The installation of guy will involve the following works:

- (i) Excavation of pit and fixing guy rod;
- (ii) Backfilling and compacting the guy foundation;
- (iii) Fastening guy wire to the support; and
- (iv) Tightening guy wire and fastening to the anchor.

When installing the guy wire, the turnbuckle shall be mounted at the pole end of the stay and guy wire so fixed that the turn buckle is half way in the working position; thus giving the maximum movement for tightening or loosening. Where the existence of guy wire may be hazardous, it should be protected with a suitable PVC pipe, filled with concrete of about 2-metre length above the ground level, duly painted with white and black stripes. No guy insulator shall be located less than 3 metres from the ground.

2.3.6 Fixing of cross arms and insulators

After the erection of supports and providing guys, the next step would be to mount the cross arms on the support. The practice of fixing the cross arm before the pole is erected is followed sometimes but only after the pole painting. In case, the cross arm is mounted after the support is erected, the line-man should climb the support having requisite tools with him. The cross arm is then tied to a hand line and pulled up by the ground man, through a pulley till the cross arm reaches the line-man. The ground man should station himself well to one side so that if any material drops from the top of the pole it may not

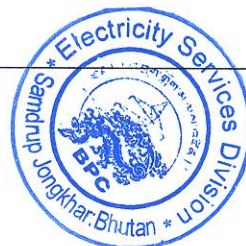

strike him. All the materials required should be lifted or lowered by means of the hand line. In no case, the materials or the tools should be dropped or thrown from the pole top. Horizontal cross arms and pole top brackets (hamper assemblies) for 33 kV and 11 kV lines as per construction drawings/sketches are standardized. They shall be fitted as shown on the drawings.

The pins for insulators are fixed in the holes provided in the cross arms and the pole top brackets. The insulators are mounted in their places over the pins and tightened. In the case of strain or angle supports, where strain fittings are provided for this purpose, the straps of the strain fittings are placed over the cross arm before placing the bolt in the hole of the cross arm. The nut of the straps is so tightened that the strap can move freely in horizontal direction, as this is necessary to fix the strain insulator.

2.3.7 Laying of AAAC/HV ABC/LV ABC/ACSR Conductor

During running out, the conductor drum should be securely supported on drum jacks with an axle, so that the conductor is pulled from the top of the drum. The drum jacks should be on a firm foundation and the axle of the drum jack should be leveled horizontally.

Sufficient employees shall be engaged at site to ensure that the conductors are not damaged by contact with the ground or pole hardware during running out. Stringing pulleys shall be used while stringing conductors. Care should be taken to avoid kinking, twisting or abrading the conductor in any manner. The conductor should not be trampled on, run over by vehicles or dragged over the ground. Vehicles should not be used to run out conductors.

Extreme care must be taken to avoid contact with the conductors of any other live line in the vicinity when running out or stringing conductors, and if necessary neighbouring lines should be de-energised during the stringing operation.

Stays shall be installed and kept in position before conductors are strung to avoid over straining of poles. Stringing pulleys shall be used while stringing conductors.

In installing LV aerial bundled cable, the cable must be pulled from the top of the drum and should not be dragged along the ground. A suitable 'drum brake' mechanism shall be used to prevent conductor overrun. Stringing pulleys compatible with bundled conductor shall be installed on every pole. During running out, the cable should be pulled out by hand or by using a nylon-pulling grip designed for bundled cables. Insulated conductor grips designed to prevent damage to the insulation of the conductor shall be used for tensioning. Every care must be taken to avoid damage to the conductor insulation.

2.3.8 Mid span jointing of conductors

Mid-span jointing of conductors shall use compression joints, appropriately sized for the conductor and made with a proprietary compression tool using appropriate sized dies.

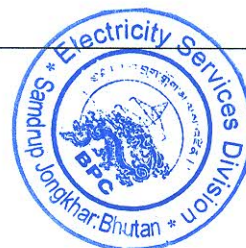

2.3.9 Sagging and Tensioning of conductors

After completion of conductor stringing and making any mid-span joints, conductor tensioning operations can commence. The conductors are first attached to the insulator string assembly at the non-tensioning end of the section, using preformed dead-ends. Further, before tensioning commences, temporary guys should be provided as necessary for the anchoring supports at each end of the line section to be tensioned to avoid over-stressing the strain poles due to unbalanced loads.

The centre conductor should be tensioned first followed by the outer two conductors. At the tensioning end, the conductor being tensioned is pulled manually up to a certain point and then a come-along clamp is fixed to it. The grip to the come-along clamp is attached to a double sheave pulley block or a pull-tight machine and the conductor is gradually tensioned.

The conductor should then be sagged in accordance with the sag-temperature chart for the particular conductor and span. These are given in Section 2.3.10 below. The correct sag should be measured in the middle span of the section.

The stretch of the conductor has to be taken out before sagging in order to avoid the gradual increase in sag, due to the setting down of the individual wires. There are two ways of accomplishing this:

(i) Pre-stressing

Using the prestressing method, the conductor is pulled unto a tension considerably above the correct figure, but never exceeding 50% of breaking load for a period of about twenty minutes. As this method requires more time and involves the use of stronger tackle to secure the higher tension, it is not commonly used.

(ii) Over tensioning

The over tensioning method consists of pulling up the conductor to a tension of 5%-8% above the theoretical tension for the prevailing temperature and fixing the conductor at that tension with correspondingly reduced sag. Over time, the conductor will settle down to the correct sag and tension.

Conductors can be sagged correctly only when the tension is the same in each span throughout the entire length of the section. Use of snatch blocks during sagging reduces the friction and chances of inequality of tension in various spans.

Measurement of conductor sag can be accomplished by several different methods but most commonly used method is 'sighting'. Targets are placed on the supports below the cross arms. The targets may be light strips of wood, which are clamped to the pole at each end of the sagging span at a distance below the conductor when the conductor is



placed in snatch blocks that is equal to the required sag. A lineman sights the sag from the next pole and the tension of the conductor is reduced or increased, until the lowest part of the conductor in the span coincides with the lineman's line of sight.

When sagging is completed, the preformed dead end should be fixed to the tension end. The dead-end and socket thimble can be fitted to the conductor without releasing the tension. A mark is made on the conductor at a distance from the cross arms equal to the length of the complete strain insulator to indicate where the dead-end should be installed.

After the dead-end has been installed and the insulator string attached to the top hamper or cross-arm, the conductor is pulled in sufficiently using the come-along clamp, to allow the insulator assembly to be fitted to the socket thimble. After the conductor is attached, the conductor tension may be released gradually. If the tension is released with a jerk, an abnormal stress may be transferred to conductor and support, which may result in the failure of the cross arms, stay or pole.

After the stringing is completed, all poles, cross-arms, insulators, fittings, etc. should be checked to ensure that there have been no deformities, etc.

The conductor is then placed on the pin insulator on each pole ready for tying and to remove the snatch blocks. On straight line poles the conductor should be tied to the top groove of the insulator and on angle poles the conductor should be tied to the side groove. The conductor is then fastened to the insulator using aluminium helities or binding wire.

In fastening the conductor to pin insulators, the following points should be observed:

- (i) The correct size of binding wire, which can be readily handled, and with adequate strength should be used.
- (ii) The length of tie wire should be sufficiently long for making the complete tie including end allowance for gripping each end.
- (iii) A good tie should provide a secure binding between the line conductor and insulator, and should reinforce the conductor on either side of the insulator.
- (iv) The use of cutting pliers for binding the tie wire should be avoided.
- (v) A helities or binding wire that has been used previously should not be reused.
- (vi) Before tying the conductor to the insulator, it shall be ensured that only the portion of helities wrapped with chloroprene pad (where applicable) touches the insulator.
- (vii) At section poles correctly sized parallel groove (PG) clamps must be used to connect the two conductor tails.



2.3.10 Conductors Sag and Tension

The following sag-span tables are provided for the guidance of field staff when stringing conductors.

2.3.10.1 ACSR Conductors

Sag-Span Chart - 33kV, Wolf

Conductor : Wolf
 Voltage : 33 kV
 Design Tension : 3.42 kN at 15°C, no wind (approx 5% MBL)

Temp	10°C	15°C	25°C	30°C	75°C
Span (m)	Sag (m)				
40	0.37	0.42	0.51	0.55	0.70
50	0.60	0.65	0.75	0.80	0.97
60	0.88	0.94	1.04	1.09	1.28
80	1.61	1.67	1.78	1.84	2.04
100	2.55	2.62	2.73	2.79	3.27
150	5.82	6.00	6.00	6.07	6.60

Sag-Span Chart – 33 kV, DOG

Conductor : Bare ACSR DOG
 Voltage : 33 kV
 Design Tension : 1.95 kN kg at 15°C, no wind (approx 5% of MBL)

Temp	10°C	15°C	25°C	30°C	50°C
Span (m)					
40	0.34	0.40	0.50	0.55	0.88
50	0.56	0.62	0.73	0.79	1.17
60	0.83	0.89	1.01	1.07	1.49
80	1.52	1.59	1.72	1.78	2.26
100	2.38	2.45	2.59	2.65	3.19
150	5.44	5.52	5.66	5.73	6.33

Sag-Span Chart – 33 kV, RABBIT

Conductor : Bare ACSR RABBIT
 Voltage : 33 kV
 Design Tension : 1.04 kN kg at 15°C, no wind (approx 5% of MBL)

Temp	10°C	15°C	25°C	30°C	50°C
Span (m)					



Technical Specifications

25	0.125	0.157	0.231	0.266	0.389
30	0.187	0.227	0.310	0.350	0.488
35	0.262	0.308	0.400	0.443	0.595
40	0.352	0.403	0.501	0.547	0.712
60	0.845	0.907	1.023	1.078	1.280

Sag-Span Chart – 11 kV, DOG

Conductor : DOG
 Voltage : Bare ACSR 11 kV
 Design Tension : 5.71 kN kg at 15°C, no wind (approx 17% of MBL)

Temp	10°C	15°C	25°C	30°C	50°C
Span (m)					
40	0.12	0.14	0.18	0.22	0.65
50	0.19	0.21	0.28	0.33	0.84
65	0.27	0.31	0.40	0.45	1.03
80	0.49	0.54	0.68	0.75	1.46
100	0.76	0.84	1.01	1.11	1.93
150	1.76	1.88	2.14	2.26	3.33
200	3.20	3.35	3.65	3.80	5.05
250	5.06	5.23	5.57	5.74	7.13
300	7.35	7.54	7.90	8.07	9.57

Sag-Span Chart – 11 kV, RABBIT

Conductor : Bare ACSR RABBIT
 Voltage : 11 kV
 Design Tension : 3.02 kN kg at 15°C, no wind (approx 17% of MBL)

Temp	10°C	15°C	25°C	30°C	50°C
Span (m)					
25	0.047	0.054	0.076	0.093	0.220
30	0.068	0.078	0.108	0.131	0.280
35	0.093	0.106	0.146	0.174	0.344
40	0.122	0.139	0.188	0.222	0.412
60	0.278	0.313	0.404	0.460	0.720

2.3.10.2 Covered AAAC/HV ABC Conductors

Conductors shall be tensioned by evenly tensioning each conductor. The sag and tension tables and recommendations of conductor manufacturer should be utilized.



2.3.10.3 Low Voltage Aerial Bundled Conductors (ABC)

Sag-Span Chart for Low Voltage ABC Conductors

Conductor Size	50mm ²		95mm ²	
	Design Tension at 15 ⁰ C (kN)	2.52	5.04	4.79
Span (m)	Sag (m)			
30	0.15			
40	0.26			
50	0.41			
60	0.59			
70	0.80			
80	1.04			
90	1.32			
100	1.63			
110	1.97			
120	2.35			
130	2.75			

Maximum Spans for Aerial Bundled Cable

Pole Length (m)	Maximum Span (m)	
	Across Street	Elsewhere
7.5	50	80 (4 core)
		100 (2 core)

Dead-end (termination) fittings shall be fitted to the conductor after tensioning at each termination point. Intermediate fittings shall then be fitted at major angles and then at smaller angles. After all fittings are in place the sagging should be checked at two places and corrected if necessary.

2.3.11 Supports at Different Elevation

Where the supports at each end of a span are at different elevations the following formula can be used for sagging the conductor.

$$d_1 = d(1-h/4d)^2$$

where:

- d₁ = vertical distance between the conductor at the lower support and the lowest mid-span point.
- d = sag for a level span equal to the slope distance between the poles. The slope distance is the distance that would be measured by a tape stretched between the two poles. Once this is known the value of d can be taken from Sag-Span chart above.
- h = difference in height between the conductor at each end of the span.



The above formula can be used to determine the value of d_1 . A sighting board can then be attached to the lower support pole and the conductor sagged by sighting horizontally through it. One way to do this would be to attach a second sighting board to the next pole. Check that the two sighting boards are level using a taut line and spirit level. The sag can then be sighted using the two sighting boards.

2.3.12 Good Conductor Stringing Work Practices

DO:

- Use proper equipment for handling aluminium conductors at all times.
- Use skids, or similar method for lowering reels or coils from transport to ground.
- Examine the reel before unreeling for presence of nails or any other object, which might damage the conductor.
- Rotate the reel or coil while unwinding the conductor.
- Unwind the conductor in the direction of the arrow on the side of the drum
- Grip all strands when pulling out the conductor.
- Control the unreeling speed with a suitable braking arrangement.
- Use wooden guards of suitable type to protect the conductor when pulling it over barbed wire fences, sharp rock edges or similar obstructions.
- Use long straight, parallel jaw grips with suitable liners when pulling the conductor in order to avoid nicking or kicking of the conductors.
- Use free-running sheaves or blocks with adequate grooves for drawing/paying conductors.
- Measure temperatures accurately with an accurate thermometer.
- Use proper sag charts.
- Mark conductors with crayons or adhesive tape or such other material which will not damage the strand.
- Make all splicing with the proper tools.

DO NOT

- Do not handle conductors without proper tools at any stage.
- Do not pull conductors without first ensuring that there are no obstructions on the ground.
- Do not pull out a greater quantity of conductor than is required.
- Do not make jumper connections on dirty or weathered conductor. Instead, clean the conductor with sandpaper. Alternatively apply a chromite or graphite conducting oxide-inhibiting grease to the point of connection and then clean the conductor with a wire brush.
- Do not handle aluminium conductor in a rough fashion but handle it with care it deserves.

At road crossings, a flagman should be in attendance to that traffic is not unduly interrupted. The running of conductor across roads should only be carried out in with the approval of the Authority responsible for the road.



Conductor drums should be transported to the tension point without injuring the conductor. If, it is necessary to roll the drum on the ground for a small distance, it should be slowly rolled in the direction of the arrow marked on the drum.

When running out conductor the drum should be so supported that it can be rotated freely. For this purpose, the drum should either be mounted on the cable drum supports or jacks or hung by means of chain pulley of suitable capacity, suspended from a tripod. If it is not possible to raise the conductor drum by any of the above methods, a trench of suitable depth slightly bigger than the conductor drum may be dug, so as to facilitate free rotation of the drum when it is suspended above the trench using a steel shaft. While running out the conductor, care should be taken to ensure that the conductor does not rub against any metallic fitting of the pole or on the uneven or rocky ground. Wooden trusses may be used for this purpose to support the conductor when running out.

Should the length the conductor be less than the length of the section, the conductors should be run out from both ends and joined where they meet with a mid-span full tension joint.

On no account, should any part of the conductor shall be left overnight at a height of less than 5 metres above the ground. The work should be so arranged that before the end of the day, the conductor is raised to a minimum height of 5 metres above the ground by rough sagging.

2.3.13 Earthing of Distribution Lines

All MV line steel poles should be separately earthed. The earth pin is a 2.5 m galvanised steel rod, which must be driven into undisturbed ground clear of the pit excavation. It is not acceptable to insert the earth rod in the pit excavation as the backfill used often does not provide a good earth connection.

The earth pin is connected to the pole using No 8 SWG galvanised steel wire/GI Strip as shown in the drawings. Lugs and bolts must be used for both the connection to the pole and to the earth pin. Wire wrapped connections are not acceptable as a good electrical connection cannot be assured.

The earth resistance of the pole and earth pin connected together should be as low as possible and ideally should not exceed 10 ohms. Additional earth pins, spaced at least 1 metre apart, should be used in difficult locations, to reduce the resistance.

The earthing stake for pole earths is also used for earthing LV distribution pillars.

The earth resistance of the earth stake and pole connected together should be measured and recorded every tenth pole. The earth resistance of a greater percentage of poles should be measured if earth resistances are high or if there is high soil variability.



2.3.14 Final Completion and Commissioning

Before commissioning a line into service, the line shall be visually checked over its full length to ensure that all structures are correctly installed, all pole earths are installed and connected, all conductors are correctly bound and terminated on all structures and all tools and other equipment have been removed.

The line shall be energised with all distribution substations isolated and unloaded on the low voltage side. Where the line is directly connected to a zone substation supply bus, rather than to an upstream line, the protective relay settings should be reduced. Once the line has been successfully energised, the correct protection relay settings should be applied and the distribution substations connected to the load one at a time.

In energising distribution transformers for the first time, the MV drop out fuse should first be closed to liven the transformer on no load. The transformer can then be loaded by closing the incoming MCCB in the LV feeder cubicle.

3. Underground Cable Installation

3.1 General Scope

This specification covers the requirements of Cabling System installation work. The installation, testing and commissioning of the complete cabling system shall be carried out as stipulated in this specification. This shall cover the requirements of supply of cabling accessories such as lugs, glands, jointing and terminating boxes/kits, junction/ marshalling boxes, cable trays, conduits and pipes to complete the work in all respects. These notes in general cover cables upto and including 33 kV rating.

3.2 Codes and Standards

3.2.1 The cabling system installation work shall comply the latest applicable standards, regulations and safety codes of the locality where the installation is carried out. Nothing in this specification shall be construed to relieve the Contractor of this responsibility.

3.2.2 The installation work shall conform to the latest applicable codes of practices, Electricity rules, Fire Insurance Regulations and standards.

3.3 Installation Work Scope

3.3.1 Scope

a) The installation work shall include unloading, storing, laying, fixing, jointing/ termination, testing, commissioning and any other work items necessary completing the job.



- b) The Contractor shall furnish all supervision, laborer, tools, welding equipment, tackles and testing equipment as required for installation work. All incidental hardware and miscellaneous items such as saddles, spacers, nuts/bolts/washers, anchor fasteners, cable route and joint markers and protective covers for buried cables, cable identification tags and ferrules, nylon cord/G.I. wire, earthing as required for the cabling installation shall be deemed to be included by the Contractor as part of installation work.
- c) Civil works for constructions of built-up cable trenches/tunnels/duct banks, cable carrier supports on main pipe rack structure, provision of embedded conduits/pipes in RCC masonry structures and across roads are included in Contractor's scope.
- d) The Manufacturer's drawings, cable schedules, instructions and recommendations shall be correctly followed by the Contractor in handling, laying, testing and commissioning of the cabling system. In case of any doubt/misunderstanding as to correct interpretation of drawings/instructions, necessary clarifications shall be obtained by the Contractor from the Employer.
- e) Any changes in routes of cables which are required to be made to suit site conditions shall be carried out by the Contractor in consultation with the Engineer and after his approval. All such changes shall be marked by the Contractor on relevant drawings/in cable and conduit schedule.
- f) All thefts and damage of cables or equipment to which cables are to be connected, till the installations is handed over to the Employer, shall be made good by the Contractor.
- g) It will be responsibility of the Contractor to clean the trenches/tunnels, remove cable drums, surplus/waste materials and all other similar items after the installation work is completed.

3.3.2 Cable Laying

- a) The Contractor shall install, test and commission all power and control cables. The quantities, sizes and types of cables shall be indicated in Bill of Quantities.
- b) The cable shall be laid in built-up trenches, directly buried in ground, cable ducts, on cable trays vertical raceways, clamped on structures/walls/ceiling, pulled through pipes and conduits etc., as per the relevant cable installation practice notes and drawings.
- c) The Scope of cable laying shall include laying, pulling cable as above, proper dressing of cables on cable trays, racks, vertical raceways and supply and



Technical Specifications

installations of cable fixing saddles, spacers and nylon cord for tying as required. The installation of trefoil/wooden clamps for clamping the cables shall be included in the installation cost of relevant cables including excavation, backfilling, etc. However, during layout of cable do not drag the cable on surface of ground, roads, etc. including pulling with excessive force especially with help of vehicle.

- d) Where cables are to be installed at temperatures below 3 ° C, they shall be heated to about 10 ° C for not less than 24 hours (in a heated building or in a tent with hot air heater) to facilitate laying (otherwise the bending would damage the insulation and protective coverings of cables). The cable laying must be carried out swiftly so as not to allow the cable to cool down too much.
- e) Control cables and small power cables in trenches and tunnels shall be run in ladder type cable trays (maximum tray width 600 mm) supported on trench/tunnel carrier arms. Control and power cables shall be clamped separately. It will be the responsibility of the Contractor to check the neatness of such cable runs and to see that horizontal/vertical runs of cables are parallel to fixed axes in respective plans. The cables shall be laid to tray rungs by means of 3mm dia. nylon cord at an interval of 5000 mm and also at bends.
- f) For good sealing arrangement at entry points, suitable pipe sleeves, adequate in number and of adequate sizes shall be provided in building walls/slabs for passage of cables into a building from cable trays/racks/cable trenches located outside the buildings.

3.3.3 Cabling

- a) Standard cable grips and reels shall be utilised for cable pulling. Care shall be taken to avoid damage to the cable and seal, which shall be made up and maintained during cable installation. If unduly difficult pulling occurs, the Contractor shall check pull required and suspend further pulling until further procedure has been approved by the Engineer. Maximum pull tension shall not exceed recommended value for the cable measured by the tension dynamometer. In general, any lubricant that does not injure the overall covering and does not set up undesirable conditions of electrostatic stress or electrostatic charge may be used in pulling insulated cables in conduits and ducts. In particular soap shall not be used as lubricant. For cables over 2,000 volts and having non-metallic jackets without adequate static shielding, the lubricant should not include graphic or hygroscopic greases that will leave a conducting film on the surface of the cable. It is not considered likely that all cable to be pulled from any pulling location can be pulled consecutively without moving and later backtracking, and it may be required that cables reels and equipment be moved from pulling locations when no actual pulling is in progress to allow performance of collateral work, and when so requested by the Engineer, such reels and equipment shall be removed. When pulling cable from any pulling location, reels shall be laid out from locations, which will permit performance of collateral work without obstruction.



Technical Specifications

- b) After pulling cable, the Contractor shall record cable identification and date pulled, neatly with water-proof ink on linen tags at all cable ends. This is in addition to the cable identification tags to be tied by GI wire at each end of the cable.
- c) Cable take-off from drums shall be so planned as to avoid using joints and splices in the run of the cable. Cable splices will be made only after obtaining permission of the Engineer. Splices where permitted, shall be made in a neat workmanlike and approved manner by man specialised in this class of work, particular attention being paid to higher voltage splices and splices involving armour or lead sheath constructions. Splices shall be made by the Contractor for each type of wire or cable in accordance with the instructions issued by the cable Manufacturer and the Engineer. Before splicing, insulated cables shall have conductor insulated stepped and bound or pencilled for recommended distance back from splices to provide along leakage path. After splicing, insulation equal to that of the spliced conductors shall be applied a teach splice. In baring conductors for splices, care shall be taken to avoid nicking of strands.
- d) Cables shall be protected at all times from mechanical injury and from absorption of moisture at unprotected ends. Damaged cables shall be replaced at the Contractor's expense.
- e) Sharp bending and kinking of cables shall be avoided. The bending radii for various types of cables shall not be less than those specified below, unless specified in cable installation notes.

DESCRIPTION	SINGLE CORE	MULTICORED ARMOURED	MULTICORED UNARMOURED
PVC insulated cable upto 11 kV	20 D	12 D	15 D

Where D = Overall diameter of cable.

(For XLPE insulated cables, recommendations of manufacturers to be followed).

If shorter radius appears necessary, no bend shall be made until clearance and instructions are obtained from the Engineer.

The above values may be reduced to 70% when making only one bend such as in case of installing an end termination.

- f) When power cables are laid in the proximity of communication cables, minimum separation between power and communication cables shall be not less than 460 mm for single-core cables and 300 mm for multi-core cables. Power and communication cable shall, as far as possible, cross at right angles to each other.

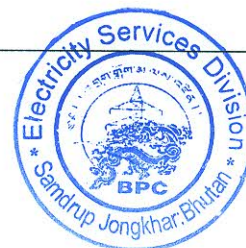

Technical Specifications

- g) The end portions of directly buried cables shall be protected as indicated in the relevant enclosed typical drawing by bringing out the cables from earth at the entry/exit points in conduits/pipes.
- h) Unarmoured cables shall be protected in conduits up to 2.5 meters from floor level.
- i) The Contractor shall make connections to small electrically operated devices on equipment installed as accessories to, or assemble with other equipment and requiring two-wire or three-wire connections. Connections to recording instruments float switches, limit switches pressure switches, thermocouples, thermostats and other miscellaneous equipment shall be done as per the Manufacturer's drawings and schedules.
- j) The Contractor shall be responsible for correct phasing of the motor power connections and shall interchange connections at the motor terminal box, if necessary, after each motor is test run.

3.3.4 Cable Termination

- a) All cables that will be laid by the Contractor shall be connected at both ends to switchgear, panels, equipment, local push buttons, instruments or junction/marshalling boxes terminals as the case may be.
- b) The scope of termination at each and shall include dressing and connection of all the cores of the cables. The following shall be included in this scope of work:
 - (i) Making the requisite holes in the bottom/gland plate of the switchgear for cable boxes/glands, fixing the cable boxes/glands, terminating the cables in the cable boxes/glands, earthing the cable armour, crimping the cable lugs on each core neatly, clamping the cables inside switchgear/panels cable alleys, wiring troughs and connecting to correct terminals as per the Manufacturer's wiring diagrams and cable schedules. The cable and core identifying lugs and ferrules respectively shall be supplied and installed by the Contractor as part of cable termination work.
- c) All cable terminations shall be solderless crimping type. Proper crimping tools shall be used by the Contractor. The crimping tools used shall be subject to the Engineer's approval.
- d) Spare cores of control cables shall be connected to spare terminal blocks, where available, with appropriate ferrules. If there are no spare terminal blocks, the spare core shall be bunched together and shall be neatly kept inside the panel.
- e) At cable terminal points where the conductor and cable installation will be terminated, terminations shall be made in a neat, workmanlike and approved manner

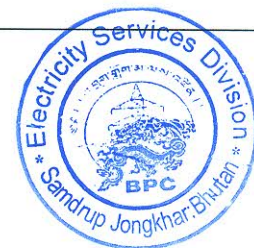

by men specialised in this class of work. Terminations shall be made by the Contractor for each type of wire or cable in accordance with instructions issued by cables Manufacturer and the Engineer. The Contractor shall have on hand at the job site the Manufacturer's drawings on high voltage cable terminations. Terminations shall be made using compression type lugs. Main runs of power and control cables will consist of PVC/XLPE insulated armoured or unarmoured cables. Terminations of such cables will generally occur in terminal boxes where splices may be required, using a special compressing or clamp type termination, beyond which PVC insulated conductor, will continue to the terminals of the control device. Terminal boxes in which splices occur will require filling with compound after completion of splices.

- f) Where terminal boxes have wiping sleeves, the lead sheath of cable shall be belled in an approved manner to fit, and a standard wiped joint made, using steaming flux and lead heated to proper temperature. Where conduits continues with cable to terminal box and mechanical clamping of lead sheath of cable is required, sheath shall be belled, trimmed and clamped in a good and approved manner. Before any cable terminal connections are made, conductors shall be rung out and identifying tags shall be installed as required by the Engineer. Connections shall be made according to wiring diagrams. Polarity of phasing shall be checked before connections are made, and correction of polarity, phasing or rotation shall be made by the Contractor without additional cost.
- g) Control cable terminations shall be made in accordance with wiring diagrams/cable interconnection diagram and cable schedules. It is intended that the Contractor shall terminate the cables which he installs. Additional work of testing and reconnection where leads have been brought by the Contractor to terminal boards and connected, but where on further testing, reversal or other rearrangement of load turns out to be necessary, additional work of testing and reconnecting shall be performed by the Contractor at no extra cost to the Employer.
- h) When control cable cores are to be fanned out and cabled together with core, the Contractor shall make connections to terminal blocks, and test equipment for proper operation before cables are corded together. If there is any doubt as to proper connection, the Contractor shall make temporary connection with sufficient length of cable so that cable can be switched to another terminal without splicing cable. Splices will not be accepted, and any cable cut out short shall be replaced and installed, at the Contractor's expense. After correct connections are established through operating equipment, cables shall be cut to correct lengths connected to terminals in the specified manner and corded together where necessary to hold cables in place in a workman-like manner.

3.3.5 Associated Work for Direct Burial of Cables, Conduits and Pipes

- a) The Contractor's scope of work for the cable trenches required for directly buried cables shall include excavation, preparation of riddled soil bedding, supply and installation of protective covers i.e. tiles for HT cable and bricks for LT cables,



Technical Specifications

back-filling, ramming and installation of route markers and joint markers. The details of construction work and provision of protective covers and markers shall be as indicated in the enclosed drawings of installation practice for directly buried cables. The sizes of these trenches shall be as indicated in the Drawing.

- b) The Contractor's scope of construction work for directly buried pipes/conduits shall be excavation and back filling as per varying depths/widths required in drawings.
- c) In each cable run greater than 50 metre, some extra cable length shall be kept at a suitable point to enable a straight through joint to be made should the cable develop fault at a later date.
- d) Where cables cross roads, water or sewage pipes, the cable shall be laid in hume or steel pipes. For road crossings the pipe for the cable shall be buried at not less than 600 mm unless otherwise noted in the drawings. Hume pipes shall be preferred to that of steel pipes from the point of view of corrosion.

3.3.6 Cable Joints

- a) Cables to each circuit shall be laid in one continuous length. Cable jointing and splicing shall be done after obtaining Site Engineer's permission. The work shall be carried out as per the cable and jointing kit Manufacturer's instructions furnished to the Contractor.
- b) The scope of jointing of various sizes and types of power cables indicated in Bill of Quantities shall include all necessary special tools and incidental accessories for testing of the joints and as per specification.
- c) Directly buried cables shall be laid as per the drawings and cable route markers shall be provided. At least one marker shall be provided if the length of the buried cable is less than 15 metres. Buried cables in trefoil formation shall be bound by plastic tapes or 3mm dia. nylon core every 750 mm.
- d) Jointing of cables shall be carried out in accordance with relevant Standard Codes of Practice and the Manufacturer's special instructions. Hardware like clips and clamps and tools required for cable jointing work shall be supplied by the Contractor. Cables shall be firmly clamped on either sides of a straight through joint at not more than 300 mm away from the joints. Identification tags shall be provided at each joint and at all cable terminations. Single core cable joint shall be marked so that phase identity at each can be determined easily. The joints shall be located at the most suitable places. There shall be sufficient overlap of cables to allow for the removal of cable ends which may have been damaged.
- e) Joint pits shall be of sufficient dimensions to allow the jointers to work with as much freedom as possible. When two or more cables are laid together, joints shall be arranged to be staggered by about three metres.



- f) Cable seal shall be examined to ascertain if they are intact and also that cable ends are not damaged. If the seals are found to be broken or lead sheath punctured, the cable ends shall not be jointed until after due examination and testing by the Engineer. Before jointing is commenced, insulation resistance of both sections of cables to be jointed shall be checked by megger and insulation values recorded.

3.3.7 Junction/ Marshalling Boxes/ Button Station Installation

- a) The Contractor shall install the junction/marshalling boxes wherever necessary.
- b) The scope of installation of junction/marshalling boxes and push-button stations shall be mounted on wall, columns, and structures, including necessary bolts, nuts, screws and welding work as necessary.
- c) Cable entry to motors, push button stations and other electrical devices shall be from the bottom as far as possible or from the sides. Top entry shall be avoided particularly for outdoor equipment.
- d) Identification tags made from aluminium sheet shall be attached to each end of each cable by means of GI binding wire as shown in drawing. Tags shall be additionally put at an interval of 30 meters on long runs of cables and in pull boxes.
- e) Wooden cleats when required for vertically supporting on or more single core cables per phase, such as on vertical framework near transformer cable boxes, shall be made out of well-seasoned wood given two coats of fire retarding paint of approved quality.

3.4 Earthing of Cables

- a) Metallic sheaths, screens and armour of all multicore cables shall be earthed at both equipment and switchgear end.
- b) Sheath and armour of single core power cables shall be earthed at switchgear end only. If specifically indicated in drawings, for long lengths of cables multiple earthing may have to be adopted to safeguard against the presence of standing voltage under normal as well as fault conditions.
- c) Earthing of CT and PT neutral lead shall be at one end only.
- d) Metal sheath and armour of the cable shall be bonded to the earthing system of the station. Bond shall be of at least 70 sq.mm copper conductor unless otherwise specified.



3.5 Testing of Cables

- a) All new cables shall be megger tested before jointing. After jointing is completed all L.V. cables shall be megger-tested and H.V. cables (3.3 kV and above) pressure tested before commissioning. The test voltage for pressure testing shall be as per the relevant cable standards. 1100/650 Volt grade cables shall be tested by 1000 volt Megger.
- b) The Contractor shall furnish all testing kit and instruments required for field testing.
- c) All cables of 1.1 kV grade 400 sq.mm and above and all HV cables shall be subjected to DC or AC high voltage test after jointing and terminating but before commissioning as per the relevant standards. Testing with DC voltages should be preferred as test equipment required is compact, easily portable and requires low power. The cable cores must be discharged on completion of DC high voltage test and cable shall be kept earthed until it is put into service.
- d) DC test voltage for old cables is 1.5 times rated voltage or less depending upon the age of cables, repair work or nature of jointing work carried out.
- e) In each test, the metallic sheath/screen/armour should be connected to earth.
- f) Continuity of all the cores, correctness of all connections as per wiring diagrams, correctness of polarity and phasing of power cables and proper earth connection of cable gland, cable boxes, armour and metallic sheath shall be checked.

4. Installation of Distribution Transformer Substations

4.1 Selection of Site

The location of distribution transformer substations should ideally be:

- as close as possible to the centre of the load, in order to reduce the voltage drop in the low voltage circuits;
- in a location that is clear of obstructions and that provides satisfactory access for the incoming medium voltage overhead distribution line;
- readily accessible for transportation of the distribution transformer to site;
- above a road rather than below it where this is practical; and
- in a location likely to provide a low resistance to earth.

4.2 Installation of PAD Mounted Distribution Transformers

This method is suitable for transformer capacity of 250 kVA and above. The floor level must be higher than the surroundings to prevent flooding. The foundation should be preferably of concrete. The type of foundation permits drainage of the transformer.



Gravel should be spread all round for the purpose of effectively controlling the growth of grass and weeds and to prevent the spreading of dust. A soaking pit shall be constructed for the absorption of the leaking oil. If a number of transformers are located close together, fire proof barrier walls should be provided to limit the damage arising from a mishap to any transformer. The enclosures of floor-mounted transformers should be designed to permit free circulation of air on all sides. If possible, the outdoor transformers should be protected against direct sun's rays. This will lower the maintenance charges on painting and also prolong their life. The roller of the transformers after being placed in its final position should be firmly locked to prevent any movement during storms.

4.3 Fencing Arrangement

Pad mounted substation should be enclosed around preferably with chain link fencing or netting of one strand of barbed wire at the top. This is done to keep away animals and unauthorized person entering into the substation yard. Suitable gates should be provided for transporting the equipment in the yard. Good illumination is necessary in a substation to ensure normal operation and maintenance activities and safety of working personnel. Generally, 10x10 meter fencing is provided as substation fencing for pad mounted transformers. For bulk transformers, where HT meter equipment is to be provided in the substation yard, 10x15 meter yard fencing is to be provided. These days such arrangements were constantly being replaced by compact substations/unitized substation. Details of substation fencing is given on drawing no. BPC-DDCS-2015-63.

4.4 Substation Earthing

Particular care should be given to the construction of the earthing system as proper earthing of distribution transformer substations is necessary to ensure safe operation of the supply system. The earth pits should be located as shown in drawing and the earth connections to the substation structure are shown in drawing BPC-DDCS-2015-64.

BPC's standard earthing conductor for transformer substation is 25x3 mm galvanized iron flat. Three electrodes forming an equilateral triangle with minimum distance of 6500mm, so that adequate earth buffer is available. Each electrode shall be GI pipe of 4 mm thick, 40mm outer dia and 2500mm long and buried vertically so as to leave about 4 inch pipe length above ground level to fix a 250x250mm G.I plate. The three earth electrodes should be connected together by an equi potential earthing ring embedded at least 100 mm below ground level. These are connected as follows:

- 1) One earth electrode is connected to earth lighting arrestor and the transformer tank. It is important that the earthing conductor is kept as short as possible.
- 2) The second earth electrode is connected to the transformer LV neutral bushing, the transformer tank and the crossarms supporting the drop-out fuses.
- 3) The third earth electrode is also connected to the transformer tank and LV neutral and also to the earth in the low voltage distribution cabinet.



There shall be minimum joints preferably no joints enroute to earth electrodes. Where joints are unavoidable, they shall be brazed, riveted or welded (and painted with red lead and aluminium paints one after the other and finely coated with bitumen).

4.5 Transportation and Handling of Transformers

Distribution transformers should be stored in such a way that 'first in first out' becomes a normal procedure. Care must be taken to place the transformers in store in such a fashion that no damage occurs to tank, bushings, etc. due to movement of personnel and materials.

Transformers should be loaded and unloaded with care. Prior to loading a transformer for dispatch to site, the transformer condition (bushings, fittings, tank, oil level, etc.) should be checked. If any damage is noticed, the in-charge should be notified immediately, and transformer should be loaded only after the written approval of the person in charge. The BDV value of the transformer oil should be checked and transformer should be loaded only after written approval of the In-Charge.

Every transformer dispatched to site should be entered individually in store register. This register should have the following:

- (i) Serial Number
- (ii) Date of receipt
- (iii) Transformer capacity (kVA)
- (iv) Manufacturer's name
- (v) Date of Despatch to site
- (vi) Name of site
- (vii) Technical test reports

Transformers should be lifted using the lifting lugs provided on the transformer tank and the lifting arrangement should not cause unbalance of the transformer. Before lifting the complete transformer, it should be ensured that all cover bolts are tightened. The slings, lifting tackle, etc. to be used in hoisting of transformers should have adequate strength to handle the weight.

During transport of transformers, they should be rigidly secured to the transport vehicle and packing materials put on either side of the base of the transformer to prevent skidding. A responsible official shall supervise the loading. Rollers, if provided, should be removed.

Care should be taken in transporting transformers to site to prevent the transformers moving when going up and down hills and around corners.

Transformer should be brought just adjacent to the mounting structure for installation. Lifting tackle should be used for hoisting transformer on structure.



In case, it is not possible to bring the vehicle carrying transformer near the mounting structure, it should be unloaded at a nearest safe place and carried to the mounting structure manually with great care and under proper supervision or shifted on platforms fitted with rollers.

While installing transformers on the Transformer Platform, safety precautions by way of fixing additional clamps and bolts should be taken.

Readymade slings to suit the capacity of transformer should be available.

4.6 Substation Structure and Earthing

The distribution substation structure and earthing of the equipment and structure shall conform to the relevant construction drawings. The maximum permissible earth resistance is 5 ohms.

4.7 Protection of distribution transformers

Dropout fuses are provided on H.V side of the transformer for isolating and protection.

MCBs and fuses are provided on the LT side of the transformer for isolating and for protection against feeder faults.

Acceptable Transformer Medium Voltage Fuse Link Ratings

MV Rating (kV)	Phases	Capacity(kVA)	Rated Current(A)	Fuse Link(A)
33	3	63	1.1	2 to 4
33	3	125	2.2	4 to 7
33	3	250	4.4	9 to 16
33	3	500	8.7	16 to 32
33	1	10	0.3	1 to 2
33	1	16	0.5	1 to 2
33	1	25	0.8	2 to 3
11	3	16	0.8	2 to 3
11	3	25	1.3	2 to 4
11	3	63	3.3	7 to 9
11	3	125	6.6	16 to 25
11	3	250	13.1	32 to 40
11	3	500	26.2	50 to 100
11	3	1250	65.6	150 to 300
11	1	10	0.9	2 to 3
11	1	16	1.5	3 to 7



Technical Specifications

6.6	3	20	1.7	3 to 7
6.6	3	30	2.6	4 to 9
6.6	3	50	4.4	9 to 16
6.6	3	75	6.6	16 to 25
6.6	3	125	10.9	25 to 40
6.6	1	10	1.5	3 to 7
6.6	1	16	2.4	4 to 7
6.6	1	25	3.8	9 to 16

LV cable specification for connection from Transformer LV side to DP

Phases	Transformer Rating (kVA)	Maximum Current (A)	LV Cable Size(mm ²)
3	10	14	4Cx35
3	16	23	4Cx35
3	25	36	4Cx35
3	63	91	4Cx70
3	125	180	4Cx150
3	250	361	4cx300
3	500	722	2Rx4cx300
3	1250	1804	2Rx4cx630
1	10	43	2Cx35
1	16	70	2Cx35
1	25	109	2Cx35

4.8 Installation of Distribution/Mini Pillars

Distribution pillars are used to connect consumers service cables to the distribution cables in urban underground systems. They shall have a degree of protection of IP 55 or better with bottom cable entry to avoid water ingress. The minimum panel thickness shall be 2.5 mm, and there shall be a removable gland plate of minimum 3 mm thickness. There shall be a lockable hinged door with a minimum thickness of 2 mm. Separate aluminium phase and neutral busbars shall be provided.

Outgoing cables shall be protected by single pole miniature circuit breakers(MCBs). MCBs shall be of the hand operated, trip free, air break, thermal and magnetic tripping type and comply with IEC 60898 and IEC 60947-2.

MCBs do not have adjustable overload settings. The size of MCB to be used to protect the standard underground service cables is shown in Table.

Maximum MCB ratings for Underground Service Cable



Technical Specifications

Cable Size(mm ²)	No. of Cores	Maximum MCB rating(A) ¹
35	4	100
16	2	63
6	2	32

4.9 Connection of Supply to Consumer's Premises

Supply to consumer premises through a 2 or 4 core overhead cable in situations where consumers are fed from the overhead system and a 2 or 4 core underground cable when fed from an urban underground system.

The connection arrangement for a single phase consumer shall be as per the relevant drawings. The residual current circuit breaker (RCCB) shown in the drawing is optional but the remainder of the circuit is mandatory. All components except the energy meter shall be provided by the consumer. The energy meter will be provided by BPC.

A new connection should not be livened unless;

- The consumer has installed an MCB as a point of isolation;
- The consumer has installed a stake earth, which is connected to a main earth terminal on the consumer's distribution board;
- Each and every power point is properly earthed;
- There is a link between the earth terminal and the incoming neutral. As shown in the drawing, the configuration of this connection will depend on whether or not the customer chooses to connect an RCCB.

4.10 Consumer Metering

The choice of meter to install in consumer installation will depend on the expected load. Three types of meter are available:

- Direct connected, where the meter is directly connected to the incoming low voltage supply;
- CT metering, where the meter is indirectly connected to the low voltage supply through a current transformer; and
- High voltage metering, where the consumer is supplied at high voltage and the meter is indirectly connected to the high voltage supply through a high voltage metering unit.

4.11 Direct Connected Metering

Direct connected metering should be used when the consumer load is not expected to exceed 60 A. Standard direct connected meters used by BPC are given in table below:



Technical Specifications

BPC Standard Direct Connected Meters.

Phase	Meter Type	Capacity (A)	Class
1	Electromechanical	2.5/10	2
1	Electromechanical	5/20	2
1	Electromechanical	10/60	2
3	Electromechanical	5/30	2
3	Electromechanical	20/80	2

The class of meter indicates its accuracy and the meter capacity indicate the current range over which the accuracy can be assured. Hence a class 2 10/60 A meter can be expected to have a metering accuracy of 2 % over a current range of between 10 and 60 amps.

4.12 CT Metering

Where the consumer is supplied at low voltage and the expected maximum three phase load is greater than 60 A, current transformer (CT) metering should be used. All current transformers have a 5 A output and feed into a standard 5 A, class 1 electromechanical meter. The load shown on the meter needs to be multiplied by the CT ratio to give the actual consumption.

CTs currently used by BPC have a ratio of 100/5, 200/5, 300/5, 400/5, and 500/5 and have an accuracy of class 1 and a burden of 15 VA.

Care must be taken to ensure the correct multiplier is used when measuring consumption using CT metering.

4.13 High Voltage Metering

Consumers supplied at high voltage must provide a high voltage metering unit acceptable to BPC. The high voltage metering unit shall incorporate potential and current transformers. The current transformer shall be class 0.5, have a maximum burden of 15 VA and have either a 1 A or 5 A output. The voltage transformer shall be class 0.5, have a maximum burden of 15 VA and have a 110 V output.

BPC will connect its own class 0.5 trivector electronic meters meeting the requirements of IEC 60687 to the consumer's high voltage metering unit. The meter shall incorporate a data logging facility and be capable of recording a range of different power system parameters at the point of connection.



Section V

PRICE SCHEDULES



Price Schedule

Package: SJE01- 2021

Description of Package: Right of Way (ROW) Clearing for Distribution lines at Samdrup Jongkhar (Dewathang, Orong, Gomdar & Wangphu Gewogs)

Sl/No	Description of Work	Unit	Quantity	Rate (Nu.)	Amount (Nu)
1	<i>Bi-Annual</i> Clearing of Right of Way (ROW) along the MV line for 33 kV-12 m, cutting of trees & trunks, debranching, including thorough cleaning of bushes, creepers along the identified MV line route, within the schedule specified below. The measurement will be done as per the actual work point by point at ground zero by GPS equipment and line span will be not considered.				
a)	April to June 2021	KM	95.40		
b)	September to November 2021	KM	27.4		
2	<i>Annual</i> Clearing of Right of Way (ROW) along the MV line for 11 kV-9m, cutting of trees & trunks, debranching, including thorough cleaning of bushes, creepers along the identified MV line route, within April to June 2021. The measurement will be done as per the actual work point by point at ground zero by GPS equipment and line span will be not considered.	KM	65.60		
3	<i>Annual</i> Clearing of Right of Way(ROW) along LV line including debranching of trees, cleaning of bushes and creepers at Deothang Service Centre	KM	11		
Total for Package:SJE01-2021					



Package: SJE02- 2021

Description of package: Right of Way (ROW) Clearing for Distribution lines at Samdrupcholing (Pemathang, Phuntshothang, Martshala & Samrang Gewogs)

SI/No	Description of Work	Unit	Quantity	Rate (Nu.)	Amount (Nu)
1	<i>Bi-Annual</i> Clearing of Right of Way (ROW) along the MV line for 33 kV-12 m, cutting of trees & trunks, debranching, including thorough cleaning of bushes, creepers along the identified MV line route, within the schedule specified below. The measurement will be done as per the actual work point by point at ground zero by GPS equipment and line span will be not considered.				
a)	April to June 2021	KM	109.43		
b)	September to November 2021	KM	35		
Total for Package: SJE02-2021					

Package: SJE03-2021

Description of Package: Right of Way(ROW) clearing for distribution lines at Jomotsangkha (Langchenphu, Serthi & Lauri Gewogs)

SI/No	Description of Work	Unit	Quantity	Rate (Nu.)	Amount (Nu)
1	<i>Bi-Annual</i> Clearing of Right of Way (ROW) along the MV line for 33 kV-12 m, cutting of trees & trunks, debranching, including thorough cleaning of bushes, creepers along the identified MV line route, within the schedule specified below. The measurement will be done as per the actual work point by point at ground zero by GPS equipment and line span will be not considered.				
a)	April to June 2021	KM	117.42		
b)	September to November 2021	KM	50		
2	<i>Annual</i> Clearing of Right of Way (ROW) along the MV line for 11 kV-9m, cutting of trees & trunks, debranching, including thorough cleaning of bushes, creepers along the identified MV line route, within April to June 2021. The measurement will be done as per the actual work point by point at ground zero by GPS equipment and line span will be not considered.	KM	20		
Total for Package:SJE03-2021					



Price Schedule

Package: SJE04-2021

Description of Package: Plan and O&M Works at Samdrup Jongkhar & Samdrupcholing

A) RE Fill-in(LT extension) at Samdrup Jongkhar

SI/No	Description of Work	Unit	Quantity	Rate(Nu.)	Amount(Nu.)
1.0	Route survey, transportation of material (both headloading and vehicular from stores to sites), testing, commissioning and other associated works including jungle clearance if required.				
1.1	Digging of holes, erection of 7.5 meter poles and LV ABC fittings, and other associated works.	Nos	89		
1.2	Digging of holes, erection of stay sets assembly (elbow, stay rod, clamp, plate, insulator & wire)	Nos	84		
1.3	Laying and stringing of LV ABC conductor including jumperring and joints lines wherever necessart to complete work.				
a	4 x 50 sq mm	KM	2.362		
b	2 x 50 sq mm	KM	2.836		
II	Providing of Service conections				
1	Laying & stringing of service cables, 2x6/10sqmm	M	1410		
2	Installation of Energy meters & connections	Nos	47		
Total A(I+II)					



B) Maintenance Works at Samdrup Jongkhar

SI/No	Description of Work	Unit	Quantity	Rate(Nu.)	Amount(Nu.)
I	Earthing Improvement for Distribution Substations				
a	Survey, transportation of material (both head loading and vehicular from stores to sites), Installation/Erection of GEE Slab Earthing (1 set =10Nos. GEE Slabs of 4'X1'X2" weighing 30 kg each) including excavation of earth/trench: 12m lengthX0.5m wideX 0.75m depth per substation and backfilling, ramming of-excavated soil, and connections with Transformers at Samdrup Jongkhar-2SS, Orong-3SS, wooling-3SS, Gomdar Wangphu-4ss and Deothang-3SS	Set	15		
II	Replacement of LT RCC Poles at Deothang & Samdrup Jongkhar with Steel Tubular poles				
1	Digging of holes, erection of 7.5/9 mtr, poles and LV ABC fittings, painting, pole casting and other associated works.	Nos	26		
2	Re-Stringing of LV ABC conductor including jumperring and joints lines wherever necessary to complete work.				
a	4 x 95 sq mm or 2x50sq.mm	Km	0.5		
b	2 x 95sq mm or 2x50sq.mm	Km	0.5		
3	Dismantling of RCC poles including existing LT fittings, stay sets and other accessories and returning back of material to store.	Nos	26		
4	Disconnection and re-connection of service cable	Nos	30		
III	Replacement of ACSR conductor				
1	Stringing of ACSR Dog Conductor at Rekhey along 33kV Bangtar feeder	KM	0.3		
2	Dismantling of existing ACSR wolf conductor at Rekhey including all accessories and returning back to Division office through measurement in KM/KG	KM	0.3		
IV	Providing and fixing of pole base casting/muffler PCC 1:2:4, 500 x 500 x 750 mm at Deothang & Orong as per BPC drawing no.BPC-DCS-003/1	NO	100		
V	Painting of poles, both Aluminium and black paints for MV poles at Deothang and Sjongkhar including transportation both vehicular and head loading from regional/ESD store to sites and other related works	No	200		
Total B(I+II+III+IV+V)					



C) RE Fill-In(LT extension) under Samdrupcholing Dungkhag

SI/No	Description of Work	Unit	Quantity	Rate(Nu.)	Amount(Nu.)
I	Construction of LV ABC 4/2 core 50 sq mm				
1	Route survey, transportation of material (both head loading and vehicular from stores to sites) testing, commissioning and other associated works including jungle clearance if required.				
1.1	Digging of holes, erection of 7.5 mtr, poles and LV ABC fittings, and other associated works.	Nos	81		
1.2	Digging of holes, erection of stay sets assembly (elbow, stay rod, clamp, plate, insulator & wire)	Nos	69		
1.3	Laying and Stringing of LV ABC conductor including jumperring and joints lines wherever necessart to complete work.				
a	4 x 50 sq mm	Km	2.284		
b	2 x 50 sq mm	Km	1.673		
II	Providing of Service conections				
1	Laying & stringing of service cables, 2x6/10sqmm	M	1080		
2	Installation of Energy meters & connections	Nos	36		
Total (C)					
D) Maintenance work at Samdrupcholing					
1	Providing and fixing of pole base casting/muffler PCC 1:2:4, 500 x 500 x 750 mm in identified locations as per BPC drawing no.BPC-DCS-003/1(33kV Bangtar feeder till Samrang)	NO	50		
2	Survey, transportation of material (both head loading and vehicular from stores to sites), Installation/Erection of GEE Slab Earthing (1 set =10Nos. GEE Slabs of 4'X1'X2" weighing 30 kg each) including excavation of earth/trench: 12m lengthX0.5m wideX 0.75m depth per substation and backfilling, ramming of excavated soil, and connections with Transformers at Samdrupcholing	Set	5		



Price Schedule

3	Painting of Pole, both Aluminium and black paints for MV poles at Phuntshothang and Pemathang area, including transportation both vehicular and head loading from regional/ESD store to sites and other related work	No	100		
Total D					
Total for Package:SJE04-2021 (A+B)					

Package - SJE05-2021**Description of Package: Plan and Maintenance Works at Jomotsangkha****A) RE Fill-in(LV extension) under Jomotsangkha Dungkhag**

SI/No	Description of Work	Unit	Quantity	Rate(Nu.)	Amount(Nu.)
I	Construction of LV ABC 4/2 core 50 sq mm				
1	Route survey, transportation of material (both headloading and vehicular from stores to sites) testing, commissioning and other associated works including jungle clearance if required.				
1.1	Digging of holes, erection of 7.5 mtr, poles and LV ABC fittings, and other associated works.	Nos	83		
1.2	Digging of holes, erection of stay sets assembly (elbow, stay rod, clamp, plate, insulator & wire)	Nos	90		
1.3	Laying and Stringing of LV ABC conductor including jumperring and joints lines wherever necessart to complete work.				
a	4 x 50 sq mm	Km	2.700		
b	2 x 50 sq mm	Km	2.600		
II	Providing of Service conections				
1	Laying & stringing of service cables, 2x6/10sqmm	M	1260		
2	Installation of Energy meters & connections	Nos	42		
Total RE Fill-in (A)					



B) Maintenance Works at Jomotsangkha					
I Construction of plinth for 315 kVA at Jomotsangkha Town					
SI/No	Description of Work	Unit	Quantity	Rate(Nu.)	Amount(Nu.)
1	Earthwork in foundation trenches or drains not exceeding 1.5m in width or 10sq.m in area on plan including dressing & ramming, disposal of surplus soil within all lead & lifts All kind of soil	cu.m	3.24		
2	P/L in position plain cement concrete 1:3:6, 20 mm aggregates, excluding the cost of centering & shuttering - All work upto plinth level.	cu.m	2.16		
3	Providing & fixing centering & shuttering (form work), including strutting, propping etc. & removal of formwork	sq.m	7.20		
4	Providing & laying hand packed stone soiling or filling with stones-150mm thick	cu.m	0.39		
5	Providing & laying 12mm cement plaster in CM 1:4	sq.m	8.49		
6	Filling of trenches.sides of foundation etc. in layer <200mm using selected excavated earth, ramming etc. within lead 50m & lift 1.5m	cu.m	0.79		
Total I					
III Construction of Chainlink Fencing(10mX10m)					
SI/No	Description of Work	Unit	Quantity	Rate(Nu.)	Amount(Nu.)
1	Earth work in excavation over areas, depth >300mm, width >1.5m, area >10 Sq.m on plan, including disposal of excavated earth within 50m lead and 1.5m lift & disposed soil to be neatly dressed Ordinary Soil	Cu.m	9.79		
2	Filling of trenches, sides of foundations etc. in layers <200mm using selected excavated earth, ramming etc. within lead 50 m & lift 1.5m	Cu.m	4.80		
3	P/L in position plain cement concrete 1:3:6 ,20 mm aggregates, excluding the cost of centering & shuttering - All work upto plinth level.	Cu.m	3.27		
4	P/L RRM with hard stone in foundation and plinth in cement mortar 1:5	Cu.m	13.02		
5	P/F centering and shuttering (formwork) including strutting, propping etc. and removal of form work. - Foundation and plinth .	Sq.m	16.62		
6	Providing & laying 20mm cement plaster C.M 1:4	Sq.m	14.00		



Price Schedule

7	P/F GI chain link mesh including fixing of post or struts, GI staples (excluding the cost of post/struts, earthwork, concrete etc.) - 4mm (8 SWG) x 100mm	Sq.m	80.00		
8	Steel work rivited or bolted, in built up sections, trusses, frame works including cutting, hoisting, fixing and applying priming coat of red lead paint.- in Tees, angles, flats and channels.	Kg	1061.86		
9	Providing & applying finishing coats for the gates, angles, channels, flats, struts for all the steel works as as per intruction of site engineer	Sq.m	46.33		
10	Providing and laying hand packed stone soling or filling with stones - 400mm thick	Cu.m	36.36		
11	Providing & laying of 20mm Aggregate/Stones-100mm thick substation bedding inside the substation area	Cu.m	9.16		
12	Dismantling of existing Chain Link fencing, tranportation and handing over of dismantled materials to Store at Jomotsangkha	Lot	1.00		
Total III					
IV	Earthing Improvement for Distribution Substations				
a	Survey, transportation of material (both head loading and vehicular from stores to sites), Installation/Erection of GEE Slab Earthing (1 set =10Nos. GEE Slabs of 4'X1'X2" weighing 30 kg each) including excavation of earth/trench: 12m lengthX0.5m wideX 0.75m depth per substation and backfilling, ramming of excavated soil, and connections with Transformers at Jomotsangkha	Set	5		
v	Painting of Pole, both Aluminium and black paints for MV poles at Langchenphug including transportation both vehicular and head loading from regional/ESD store to sites and other related works.	No	100		
Total B(I+II+III+IV+V)					
Total for Package:SJE05-2021 (A+B)					



Section VI

BID FORM



Section-VI
BID FORM

To:

Divisional Manager,
Electricity Services Division,
Bhutan Power Corporation Limited,
Samdrup Jongkhar : Bhutan

Gentlemen:

1. We have examined and have no reservation to the Bidding Document including the addenda No :
2. We offer to execute in conformity with the Bidding Document and in accordance with the completion schedule specified in the Bidding Document.
3. The Total Price of our Bid, excluding any discounts offered in item (4) below is:
.....
4. The discounts offered and the methodology for their application are:
.....
5. We undertake, if our Bid is accepted, to complete the Works within (*Number*) days, calculated from the date of site handing over.
6. If our Bid is accepted, we will provide the performance security equal to **Ten percent (10%) of the contract price** for the due performance of the Contract. **However, if the bid amount is found substantially low i.e. lower by 20% compared to the employer's estimate, we shall submit the performance security equal to the difference amount.**
7. Our bid shall be valid for a period ofdays from the date fixed for the bid submission deadline in accordance with Bidding Document, and it shall remain binding upon us and may be accepted at any time before expiration of that period.
8. We are not participating, as bidders, in more than one Bid in this bidding process, other than alternative offers in accordance with the Bidding Document.
9. We understand that this Bid, together with your written acceptance thereof in your Notification of Award, shall constitute a binding contract between us, until a formal contract is executed.
10. We understand that you are not bound to accept the lowest-priced of any Bid that you may receive.

Dated this _____ day of _____, 2021
_____ (Signature)

_____ (in the Capacity of)

Duly authorized to sign Bid for and on behalf of _____

_____ (Signature of Witness)

Witness _____

Address _____



SECTION – VII

SAMPLE FORMS



SECTION – VII

1. Bid Security Form
2. Contract Form
3. Performance Security Form
4. Advance Payment Security Form
5. Form of Information for Establishment of Bidder's eligibility.
6. Form of Information for Establishment of Bidder's qualification.
7. Average Performance Scoring Form



1. Bid Security Form

WHEREAS _____ (Hereinafter called "the Bidder") has submitted its bid dated _____ for the construction of _____ (*Name of the package*) (hereinafter called "the Bid").

KNOW ALL MEN by these presents that WE _____ of _____ having our registered office at _____ (hereinafter called "the Bank") and bound unto Bhutan Power Corporation Limited (*hereinafter called the Employer*) in the sum of _____ (*Amount of the Guarantee in Words and Figures*), for which payment well and truly to be made to the said Employer, the Bank binds itself, its successor and assigns, by these present. Sealed with the Common Seal of the Bank this _____ day of _____, 2019.

THE CONDITIONS of this obligation are:

1. if the Bidder withdraws its Bid during the period of bid validity specified by the Bidder on the Bid form; or
2. if the Bidder, having been notified of the acceptance of its Bid by the Employer during the period of bid validity:
 - (a) fails or refuses to execute the Contract Form, when requested; or
 - (b) fails or refuses to furnish the Performance Security, in accordance with the Instructions to Bidders;

We undertake to pay to the Employer up to the above amount, according to, and upon receipt of, its first written demand, without the Employer having to substantiate its demand, provided that in its demand the Employer will note that the amount claimed by it is due to it owing to the occurrence of one or both of the two above-stated conditions, specifying the occurred condition or conditions.

This guarantee will remain in force up to and including _____ days after the period of bid validity, and any demand in respect thereof should reach the Bank not later than such date.

[NAME OF BANK]
by
(Title)
Authorized representative



2. Contract Form

This Agreement made this _____ day of _____, 2019, between Bhutan Power Corporation Limited (hereinafter “the Employer”) of the one part and _____ (hereinafter “the Contractor”) of the other part.

WHEREAS THE Employer is desirous that certain works should be executed by the Contractor, viz. _____ and has accepted a Bid by the Contractor for the execution and completion of such works and remedying of any defects therein. (hereinafter “the Contract Price”).

Now this agreement witnesseth as follows:

1. In this Agreement words and expressions shall have the same meanings as are respectively assigned to them in the Conditions of Contract hereinafter referred to.
2. The following documents shall be deemed to form and read and construed as part of this Agreement, viz:
 - (a) Letter of Acceptance;
 - (b) The said Bid;
 - (c) Condition of Contract;
 - (d) The Specifications;
 - (e) The drawings;
 - (f) The Price Schedules; and
 - (g) The Schedules of Supplementary Information.

This Contract sets forth the entire contract and agreement between the parties pertaining to the Works described herein and supersedes any and all earlier verbal or written agreements pertaining to the Contract.

This Contract shall prevail over all other Contract documents. In the event of any discrepancy or inconsistency within the Contract documents, then the documents shall prevail in the order listed above.

3. In consideration of the payments to be made by the Employer to the Contractor as hereinafter mentioned, the Contractor hereby covenants with the Employer to execute and complete the Works and remedy any defects herein in conformity in all respects with the provisions of the Contract.
4. The Employer hereby covenants to pay the Contractor, in consideration of the execution and completion of the Works and the remedying of defects therein, the Contract Price or such other sum as may become payable under the provisions of the Contract, at the times and in the manner prescribed by the Contract.
5. Any notice under this Contract shall be in the form of letter or facsimile. Notices to either party shall be given at such address or addresses as such party shall



specify from time to time by written notice to the other. In the absence of such notice to the contrary, notice to the Employer shall be properly addressed to :

[Employer's address and electronic transmission address]

and notice to the Contractor shall be properly addressed to :

[Contractor's address and electronic transmission address]

A notice shall be effective when delivered or on the notice's effective date, whichever is later.

IN WITNESS WHEREOF, the parties hereto have caused this Contract to be executed in accordance with their respective laws the day and year first above written.

Signature of Employer

Signature of Contractor

Signed, Sealed and Delivered by the said _____
(For the Employer) in the presence of _____

Signed, Sealed and Delivered by the said _____ (for
the Contractor) in the presence of _____



3. Performance Security Form

To: The Regional Director,
Regional Corporate Office,
Bhutan Power Corporation Limited,
Samdrup Jongkhar: Bhutan

WHEREAS (Name of the Contractor) hereinafter called "the Contractor", has undertaken, in pursuance of Contract No. _____ dated _____ to execute _____ (name of the contract) (hereinafter called "bid").

AND WHEREAS it has been stipulated by you in the said Contract that the Contractor shall furnish you with a Bank Guarantee by a recognized Bank for the sum specified therein as security for compliance with the Bidder's performance obligations in accordance with the Contract;

AND WHEREAS we have agreed to give the Contractor a Guarantee;

NOW THEREFORE we hereby affirm that we are Guarantors and responsible to you, on behalf of the Contractor, up to a total of (Amount of the Guarantee in Words and Figures) and we undertake to pay you, upon your first written demand declaring the Bidder to be in default under the Contract, and without cavil or argument, any sum or sums as specified by you, within the limit of (Amount of Guarantee) as aforesaid, without your needing to prove or to show grounds or reasons for your demand or the sum specified therein.

We hereby waive the necessity of your demanding the said debt from the Contractor before presenting us with the demand.

We further agree that no change or addition to or other modification of the terms of the Contract or of the Works to be performed thereunder or any way release us from any liability under this guarantee, and we hereby waive notice of any such change, addition or modification.

This guarantee is valid until _____ day of _____ 2019.

[NAME OF GUARANTOR]

By _____

(Title)
Authorized Representative

Date: _____

Address: _____



4. Advance Payment Security Form

To: *Regional Director, Regional Corporate Office, Bhutan Power Corporation Limited, Samdrup Jongkhar, BHUTAN.*

[Name of Contract] _____

Gentlemen:

In accordance with the payment provision included in the Clause 45 of the General Conditions of Contract to provide for advance payment, [name and address of Contractor] (hereinafter called "the Contractor") shall deposit with the Employer a bank guarantee to guarantee its proper and faithful performance under the said Clause of the Contract in an amount of *[amount of guarantee in figures and word]*.

We, the *[bank or financial institution]*, as instructed by the Contractor, agree unconditionally and irrevocably to guarantee as primary obligator and not as surety merely, the payment to the Employer on its first demand without whatsoever right of objection on our part and without its first claim to the Contractor, in the amount not exceeding *[amount of guarantee in figures and words.]*

We further agree that no change or addition to or other modification of the terms of the Contract to be performed thereunder or of any of the Contract documents which may be made between the Employer and the Contractor, shall in any way release us from any liability under this guarantee, and we hereby waive notice of any such change, addition, or modification.

This guarantee shall remain valid and in full effect from the date of the advance payment under the Contract until Bhutan Power Corporation Limited receives full repayment of the said amount from the Contractor.

Yours truly,

Signature and seal of the Guarantor: _____

[name of bank or financial institution]

[address]

[date]



7. Average Performance Scoring Form (CON03)

Name of the Contractor:-

CDB Number:-

Name of the Client:-

Name of the Project:-

Name of Inspecting Engineer:-

Award Amount:-

Date of Start of Project:-

Final Contract Amount:-

Date of Completion:-

Performance Score Table:-

<i>Sl/No</i>	<i>Description</i>	<i>Total Score</i>	<i>Score Obtained</i>
1	On-time completion	30	
2	Quality of execution	70	
Grand Total		100	

Prepared by:

Checked by:

Name and Signature (Site Engineer)
Position
Procuring Agency

Name and Signature (Supervising Engineer)
Position
Procuring Agency



Guideline for Average Performance Score from previous work (100 points)

This parameter gives points to the contractor based on its performance for every project the contractor executes.

The 100% performance score will be composed of the following parameters:

1. *On-time completion (30%)*
2. *Quality of execution (70%)*

1. On-time completion (30 points)

Scoring for this component of performance will be done by the site engineer (that is, the implementing agency). A contractor can be penalized under this component if (s)he fails to deliver the project as per the initial time-lines committed

The site engineer can penalize the contractor to an extent of 30 points. The quantum of penalty could vary as following:

- **10 points deducted for a minor default from 30 points**
(if the final completion of the project is delayed by 10 - 15% as compared to original project duration)
- **20 points deducted for a medium default from 30 points**
(if the final completion of the project is delayed by 15 - 25% as compared to original project duration)
- **30 points deducted for a major default from 30 points**
(if the final completion of the project is delayed by 25% or more as compared to original project duration)

2. Quality of execution (70 points)

The scoring on this component of performance will be done by the Site Engineer based on the following guideline.

The scoring shall be conducted for each of the following types of construction:

1. Buildings (W3);
2. Roads(W1);
3. Bridges(W1);
4. Electrical/Telecommunication(W4);

For each of the above, following percentages shall be distributed:

1. Beginning of construction - 35%



2. During the construction - 35%
3. Completion of construction - 30%

Sl. No.	Construction Components	Scoring %	Score Obtained
I	Beginning phase of Construction		
a	Plant and Equipments	5	
b	Key Technical Personnel	10	
c	Documents (contract agreement, design, drawings)	5	
d	Layout and Alignment (Survey)	15	
Sub Total		35	
II	During Construction		
a	Quality of work executed	15	
b	Work executed as per drawing (Single Pole, Trenches, transformer foundation etc.)	10	
c	Use of Safety Gadgets	10	
Sub Total		35	
III	Completion phase of Construction		
a	Finishes (Concreting, Jointing etc.)	10	
b	Testing/Commissioning	10	
c	Materials Return on time.	10	
Sub Total		30	
Grand Total		100	

Note: - The above obtained score is to be scaled down to 70.



5. Form of Information for Establishment of Bidder's Eligibility

The Bidder shall submit with the Bid a letter from Ministry of Economic Affairs validating the license and this Form to evidence the Bidder's eligibility (Refer to Clause 13 in Section II Instruction to Bidders).

Name of Bidder:	
Class of License, registered for W4 in CDB	
CDB registration number	
Numbers of Work in Hand (as of the date of bid opening)	

If the Bidder has any work in hand, the information on the contract of work(s) in hand, shall be provided in the table below for all the contract(s):

Contract No.1

Name of Project or Contract	
Name of Employer/Client	
Date of award by Employer/Client	
Date of completion scheduled	

Contract No.2

Name of Project or Contract	
Name of Employer/Client	
Date of award by Employer/Client	
Date of completion scheduled	

Contract No.3

Name of Project or Contract	
Name of Employer/Client	
Date of award by Employer/Client	
Date of completion scheduled	

Note) If the Bidder has more than 3 works in hand, the above table shall be added to describe all works in hand.

Name of Bidder: _____

Signature of Bidder: _____



6. Form of Information for Establishment of Bidder's Qualification

The Bidder shall submit with this Form to evidence the Bidder's qualification (Refer to Clause 14 in Section II Instruction to Bidders).

Name of Bidder:	
Offered Package No. / Lot No.	

List of Tools and Equipment

Tools and Equipment	Quantity in Possess

Name of Bidder: _____

Signature of Bidder: _____



List of Skilled Employee

Name of Employee	Position for the Project	Years of Experience	Graduate

List of Experience of Works done on Similar Nature

Name of Contract	Name of Employer	Completion Year	Contract Amount (Nu.)*

Note) * Approximate contract amount shall be mentioned in Nu.

Name of Bidder: _____

Signature of Bidder: _____



DRAWINGS



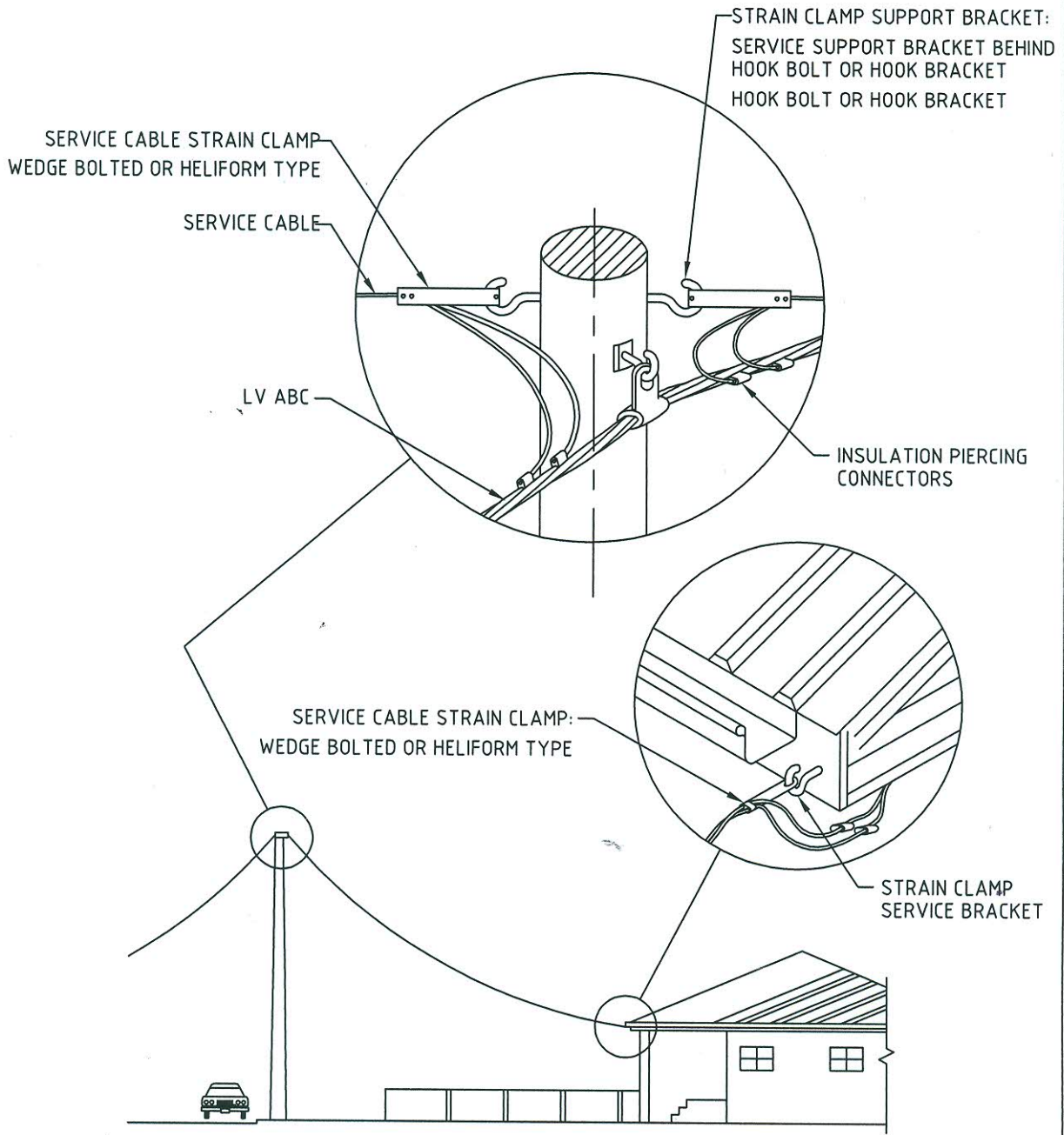

NOTES

1. DIMENSIONS AS SHOWN ARE IN mm.
2. DRAWING IS NOT TO SCALE.



BHUTAN POWER CORPORATION LIMITED

ENGINEERING DESIGN & CONTRACTS DEPARTMENT

DISTRIBUTION DESIGN AND CONSTRUCTION STANDARDS

LV ABC TYPICAL SERVICE LAYOUT ARRANGEMENT

DESIGNATION	NAME	DATE
DRAFTSMAN		
DESIGNER		
DESIGN CHECK		
PROJECT MANAGER		
PROJECT DIRECTOR		

DRAWING NO. BPC-DDCS-2015-14

REVISION
2015



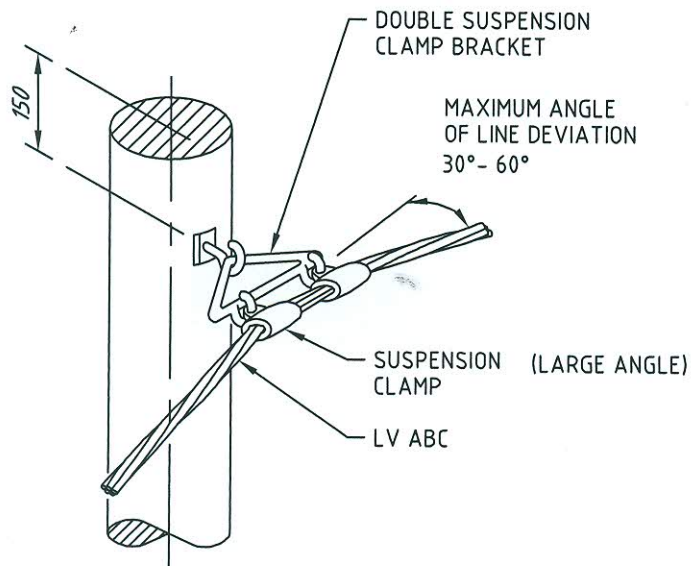
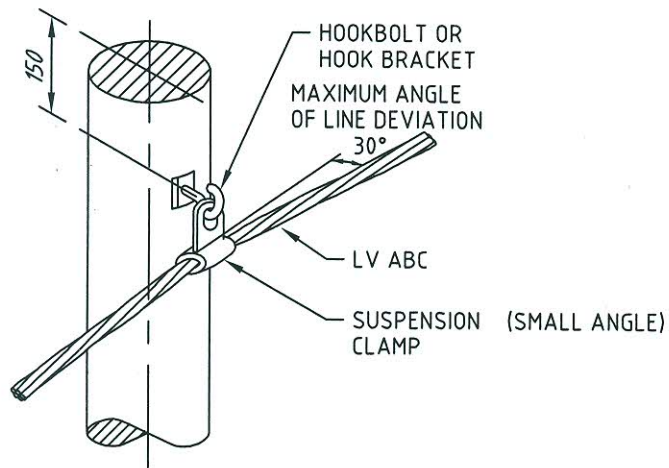

NOTES

1. DIMENSIONS AS SHOWN ARE IN mm.
2. DRAWING IS NOT TO SCALE.



BHUTAN POWER CORPORATION LIMITED

ENGINEERING DESIGN & CONTRACTS DEPARTMENT

DISTRIBUTION DESIGN & CONSTRUCTION STANDARD

LV ABC
 INTERMEDIATE & ANGLE POLES DETAILS

DESIGNATION	NAME	DATE
DRAFTSMAN		
DESIGNER		
DESIGN CHECK		
PROJECT MANAGER		
PROJECT DIRECTOR		

DRAWING NO. BPC-DDCS-2015-15

REVISION
 2015



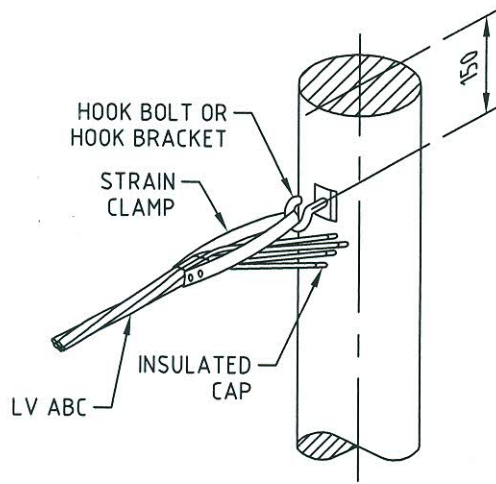

ALLOW SUFFICIENT CABLE TAIL
TO ALLOW FOR FUTURE EXTENSION

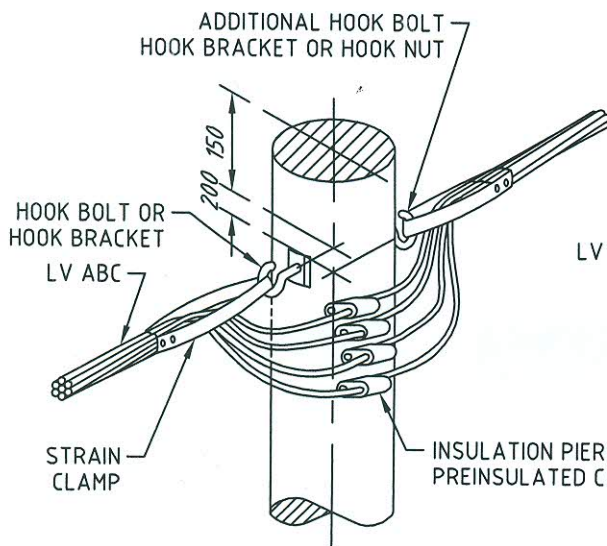

FIELD CONDITIONS MAY ALLOW
CABLE TO BE CONTINUOUS AT POLE

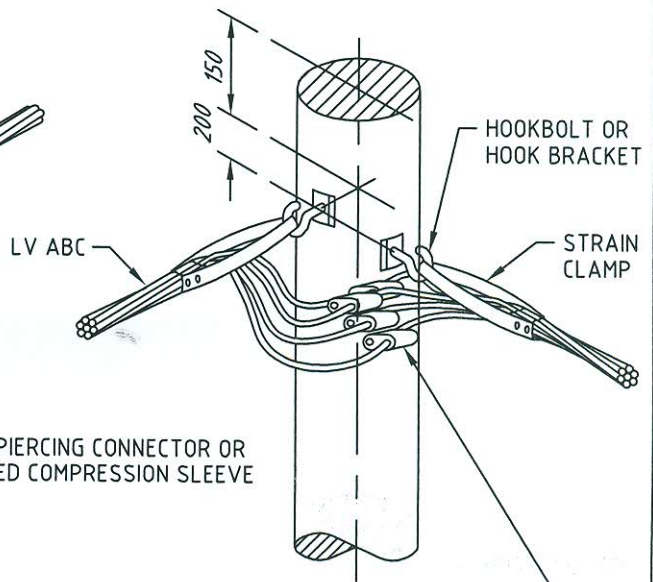

INSULATION PIERCING CONNECTOR OR
PREINSULATED COMPRESSION SLEEVE

NOTES

1. DIMENSIONS AS SHOWN ARE IN mm.
2. DRAWING IS NOT TO SCALE.



BHUTAN POWER
CORPORATION LIMITED

ENGINEERING DESIGN & CONTRACTS DEPARTMENT

TITLE : DISTRIBUTION DESIGN & CONSTRUCTION STANDARD

LV ABC TERMINATION & ANCHOR POLES DETAILS

DESIGNATION	NAME	DATE
DRAFTSPERSON		
DESIGNER		
PROJECT MANAGER		
HEAD OF DEPARTMENT		

DRAWING NO. BPC - DDCS - 2015-16

REV
2015



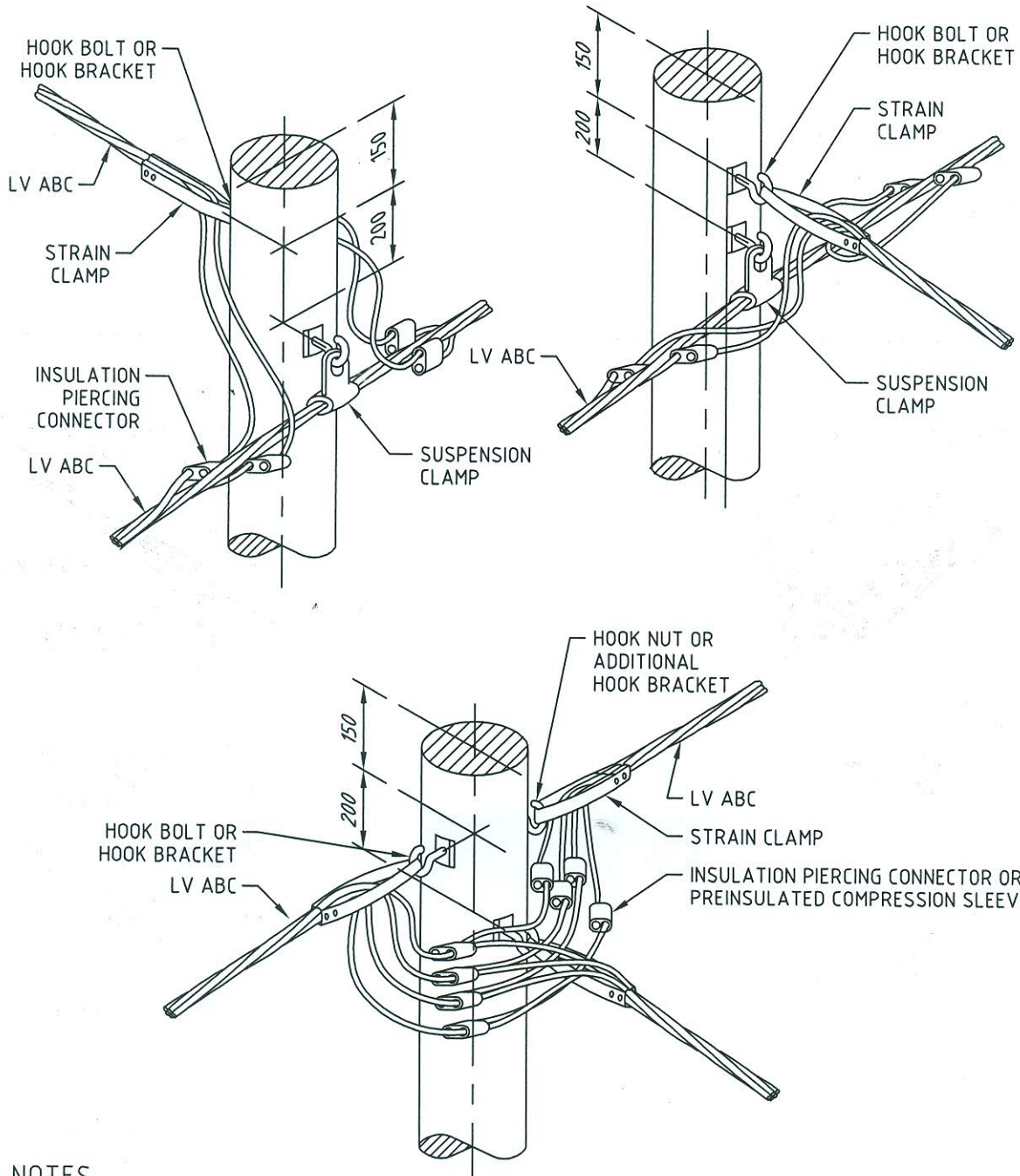

NOTES

1. DIMENSIONS AS SHOWN ARE IN mm.
2. DRAWING IS NOT TO SCALE.

 BHUTAN POWER CORPORATION LIMITED	ENGINEERING DESIGN & CONTRACTS DEPARTMENT	
	DISTRIBUTION DESIGN & CONSTRUCTION STANDARD LV ABC TEE POLE DETAILS	
DESIGNATION	NAME	DATE
DRAFTSPERSON		
DESIGNER		
PROJECT MANAGER		
HEAD OF DEPARTMENT		
DRAWING NO. BPC - DDCS - 2015-17		REVISION 2015



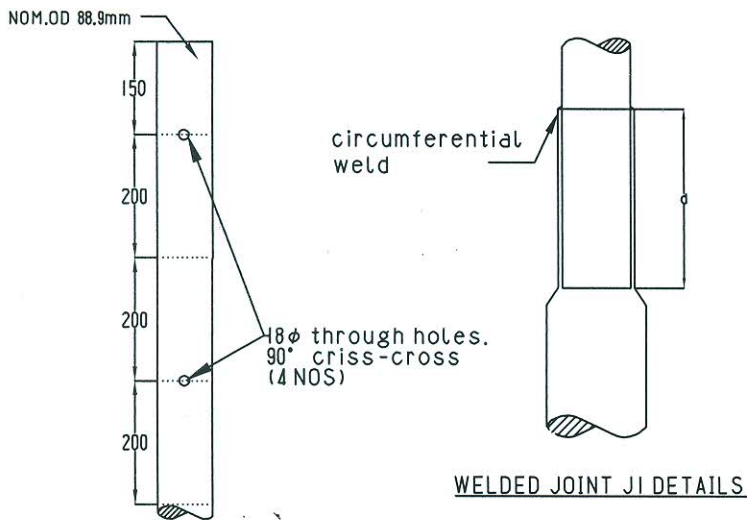

POLE TOP DETAILS

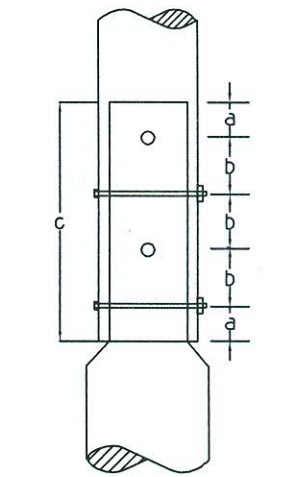

BOLTED JOINT J2 DETAILS

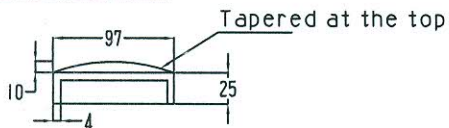

POLE CAP DETAILS (WELDED TO THE POLE)

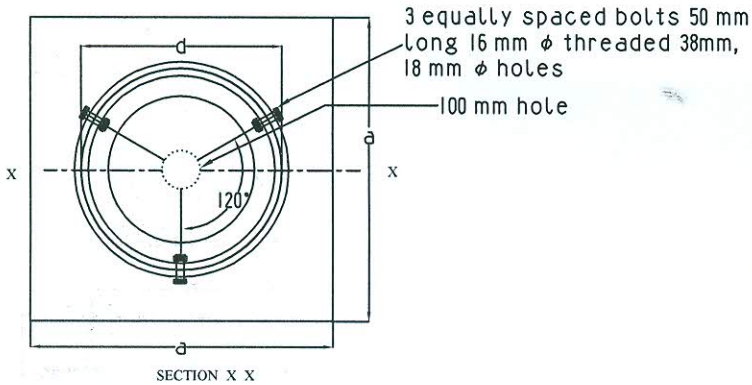
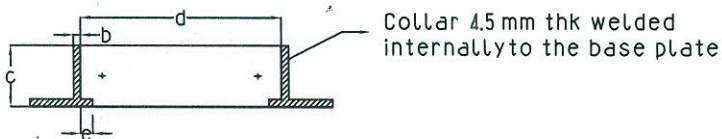

DETAILS OF MS BASE PLATE (Seperately packed)

Pole Type		7.5 M (410-SP-9)	
Length		mm	7500
Top Segment	OD	mm	88.9
	Thickness	mm	3.25
Length		mm	1500
Middle Segment	OD	mm	114.3
	Thickness	mm	3.65
Length		mm	1500
Bottom Segment	OD	mm	139.7
	Thickness	mm	5.4
Length		mm	4500
Joint J1	Welded Joint		
	d	mm	230
Joint J2	a	mm	45
	b	mm	70
	c	mm	300
	BL	mm	160
Planting Depth		mm	1250
Base plate details	a	mm	220
	b	mm	4.5
	c	mm	70
	d	mm	139.7
	e	mm	10

NOTES

1. DIMENSIONS AS SHOWN ARE IN MM.
2. DRAWING NOT TO SCALE.
3. SPECIFICATIONS AS PER IS:2713 (PART I TO III : 1980)
4. POLE TOP CAP -M.S. PLATE WOULD BE TAG WELDED TO THE POLE



BHUTAN POWER CORPORATION LIMITED

ENGINEERING DESIGN & CONTRACTS DEPARTMENT

DISTRIBUTION DESIGN & CONSTRUCTION STANDARD

7.5 METERS SWAGED POLE DETAILS

DESIGNED BY	NAME	DATE
CHECKED BY		
APPROVED BY		

DRAWING NO. BPC-DDCS-2015-19

REVISION 2015



ANCHOR ROD ASSEMBLY

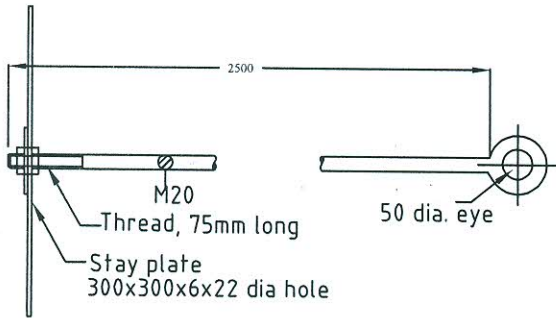

TURN-BUCKLE ASSEMBLY

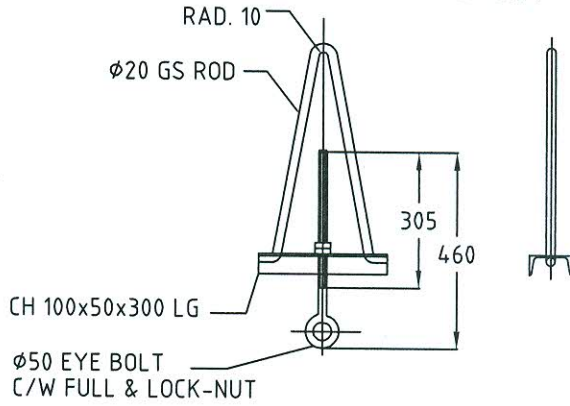

STAY PLATE

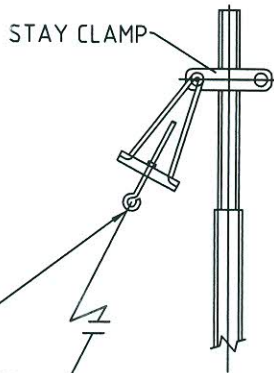
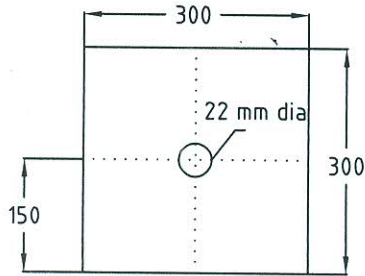

EYE BOLT

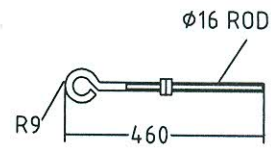

V HANGER

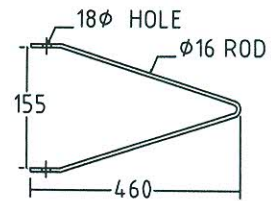

Guy preform (4 nos)

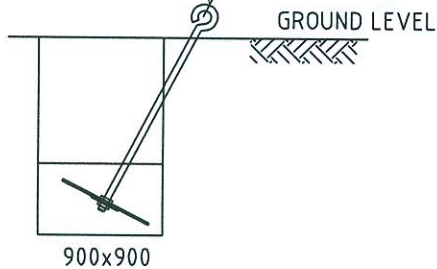

STAY WIRE ASSEMBLY

NOTES

- Stay rod and nuts assembled and packed together
- Anchor plates packed separately
- Material :- BS 4360 Grade 43A
- Galvanizing :- BS 729
- Threads :- ISO Metric
- Nut :- BS 4190 Grade 4.0

NAME OF THE ITEM	QTY	MATERIAL
V-HANGER ONLY FOR TELESCOPIC POLE	1	H.D.G STEEL
STAY WIRE (7/8 SWG) (IN METERS)	IM+POLE HEIGHT	H.D.G STEEL
STAY CLAMP WITH NUTS AND BOLTS	1	H.D.G STEEL
STAY ROD (2.5 M) WITH THIMBLE	1	H.D.G STEEL
ANCHOR PLATE (300 X 300 X 6MM)	1	H.D.G STEEL
TURN BUCKLE ASSEMBLY WITH THIMBLE	1	H.D.G STEEL
GUY PREFORMED SUITABLE FOR 7/8 SWG	4	GALVANISED STEEL WIRE
STAY INSULATOR	1	PORCELAIN



BHUTAN POWER CORPORATION LIMITED

ENGINEERING DESIGN & CONTRACTS DEPARTMENT

DISTRIBUTION DESIGN & CONSTRUCTION STANDARD

STAY SET ASSEMBLY

DESIGNATION	NAME	DATE
DRAFTSMAN		
DESIGNER		
DESIGN CHECK		
PROJECT MANAGER		
PROJECT DIRECTOR		

DRAWING NO. BPC-DDCS-2015-51

REVISION 2015

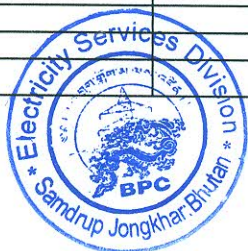

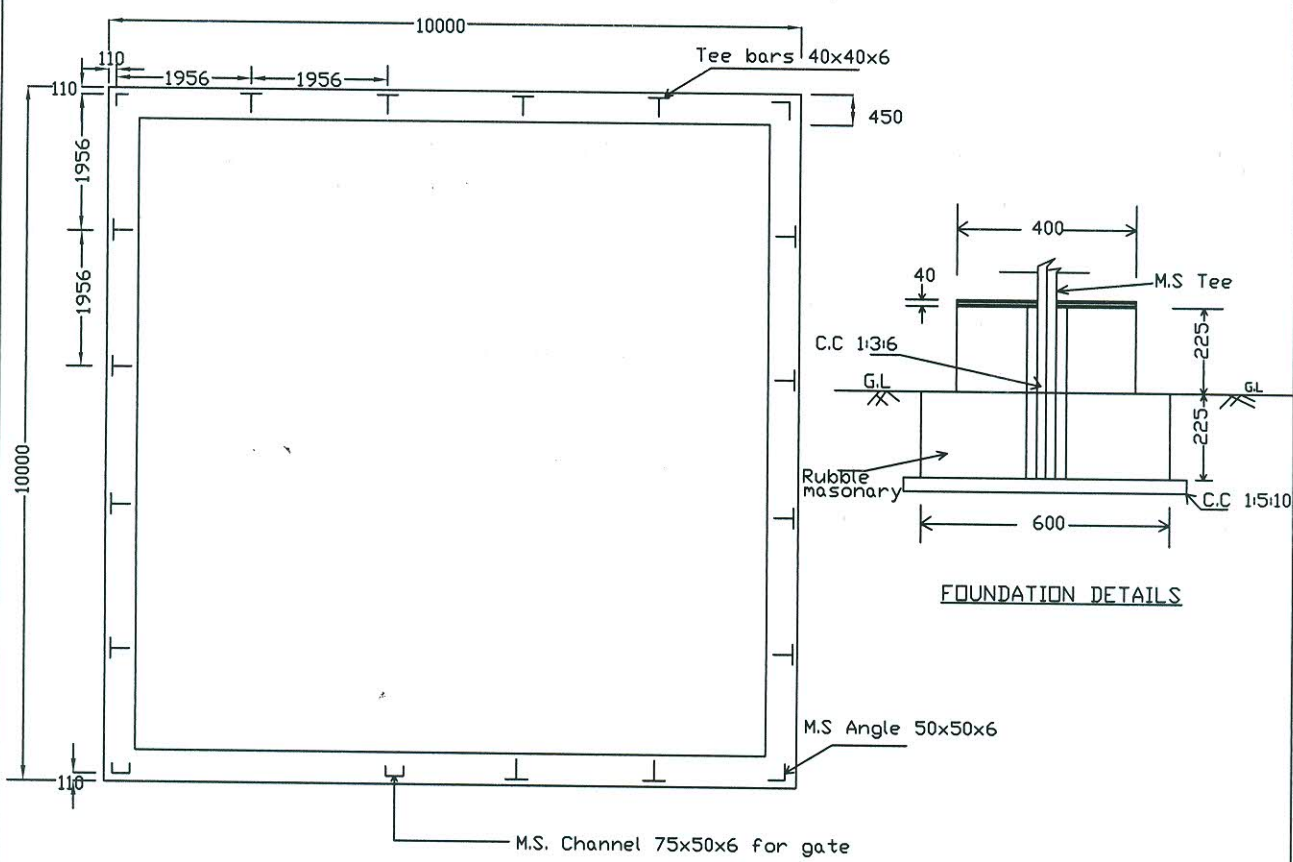

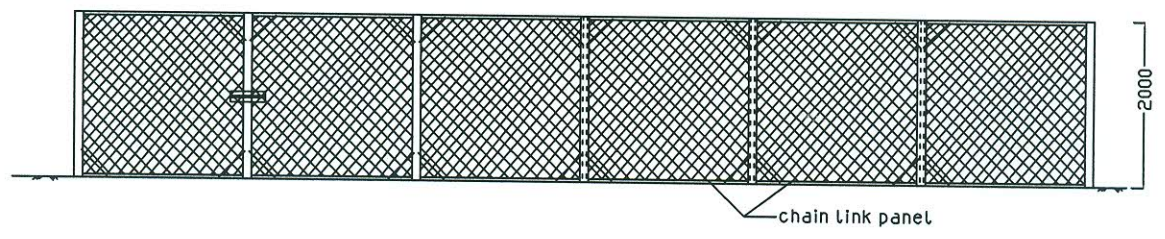

PLAN
 TRANSFORMER YARD FENCING 10M x 10M (N.T.S)

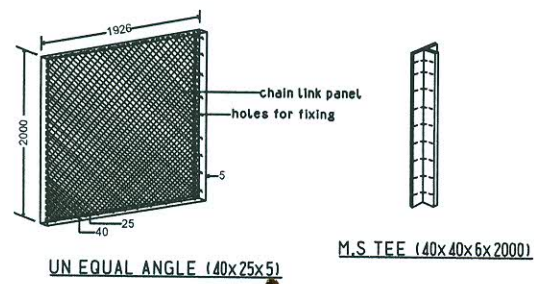

ELEVATION



UN EQUAL ANGLE (40x25x5) M.S. TEE (40x40x6x2000)

	BHUTAN POWER CORPORATION LIMITED		ENGINEERING DESIGN & CONTRACTS DEPARTMENT	
			TITLE : DISTRIBUTION DESIGN & CONSTRUCTION STANDARD CHAIN LINK FENCING FOR SUBSTATION (10 m x 10 m)	
DESIGNATION	NAME	DATE	DRAWING NO. BPC-DDCS-2015-03 	
DRAFTSMAN				
DESIGNER				
DESIGN CHECK				
PROJECT MANAGER				
PROJECT DIRECTOR			REVISION	2015

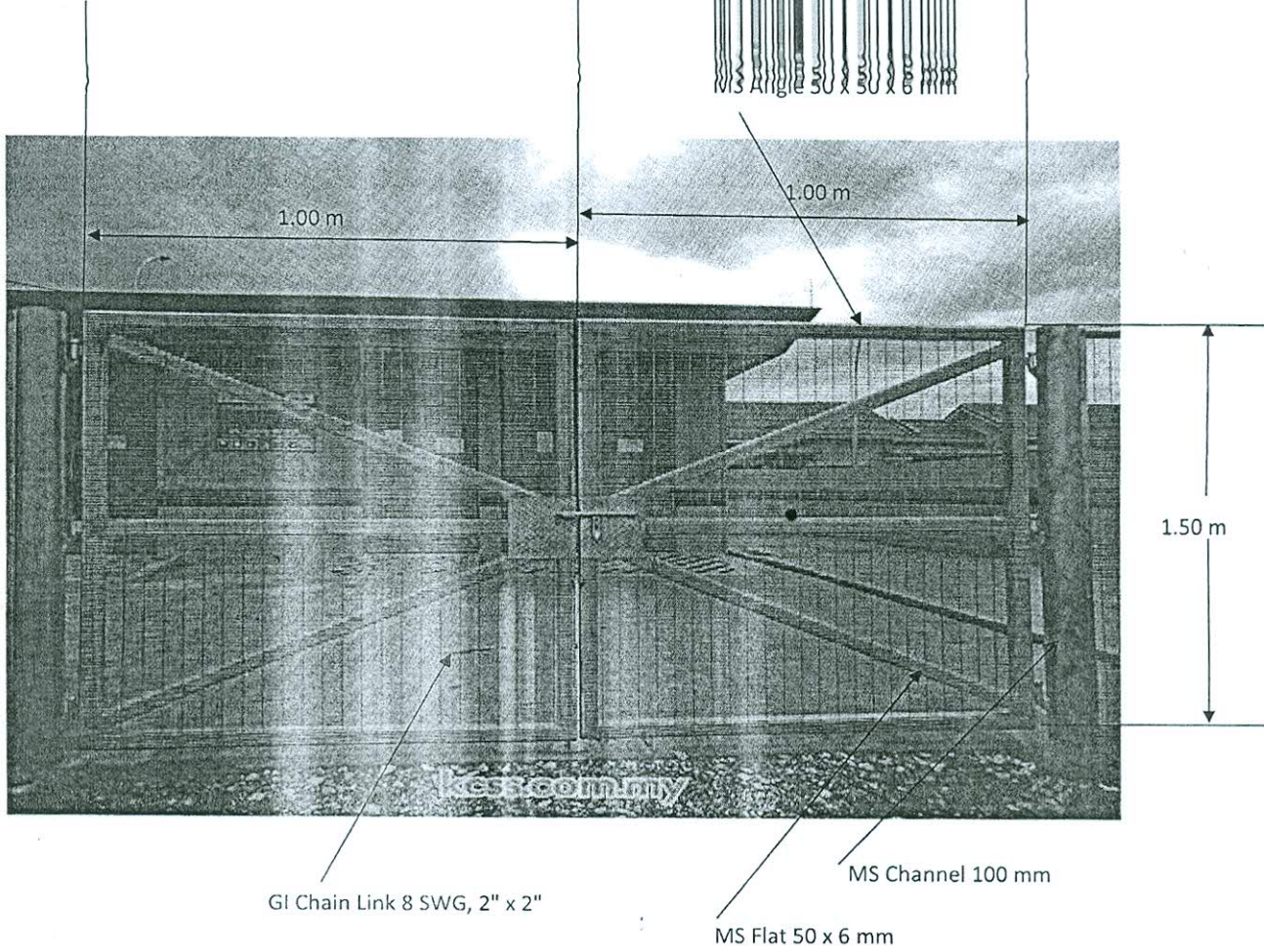

Figure:1 Detail Design of Substation gate with GI Chain link

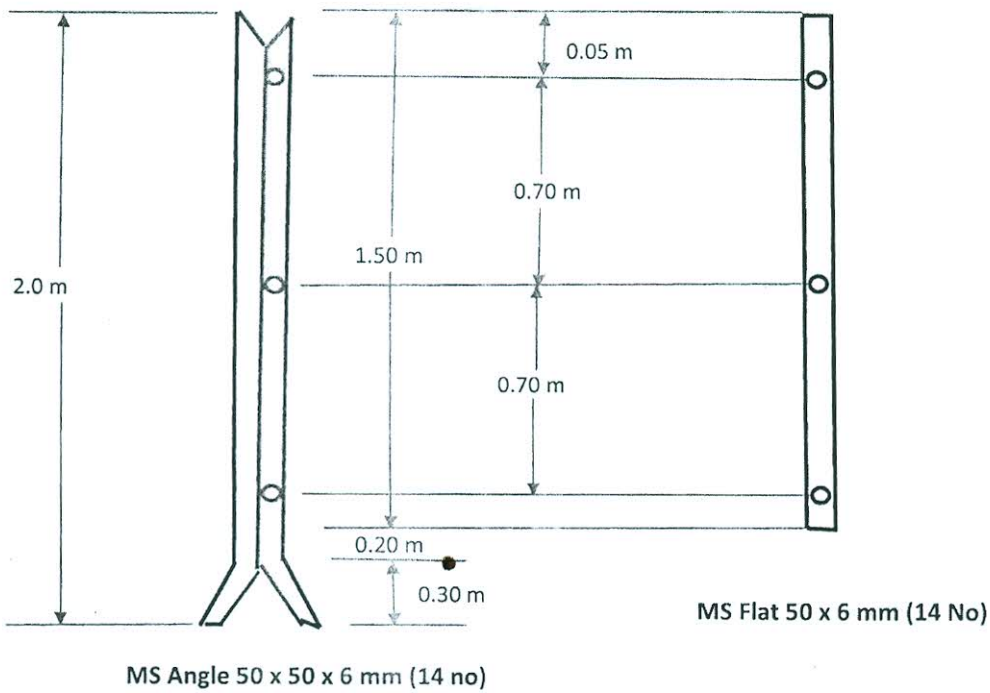
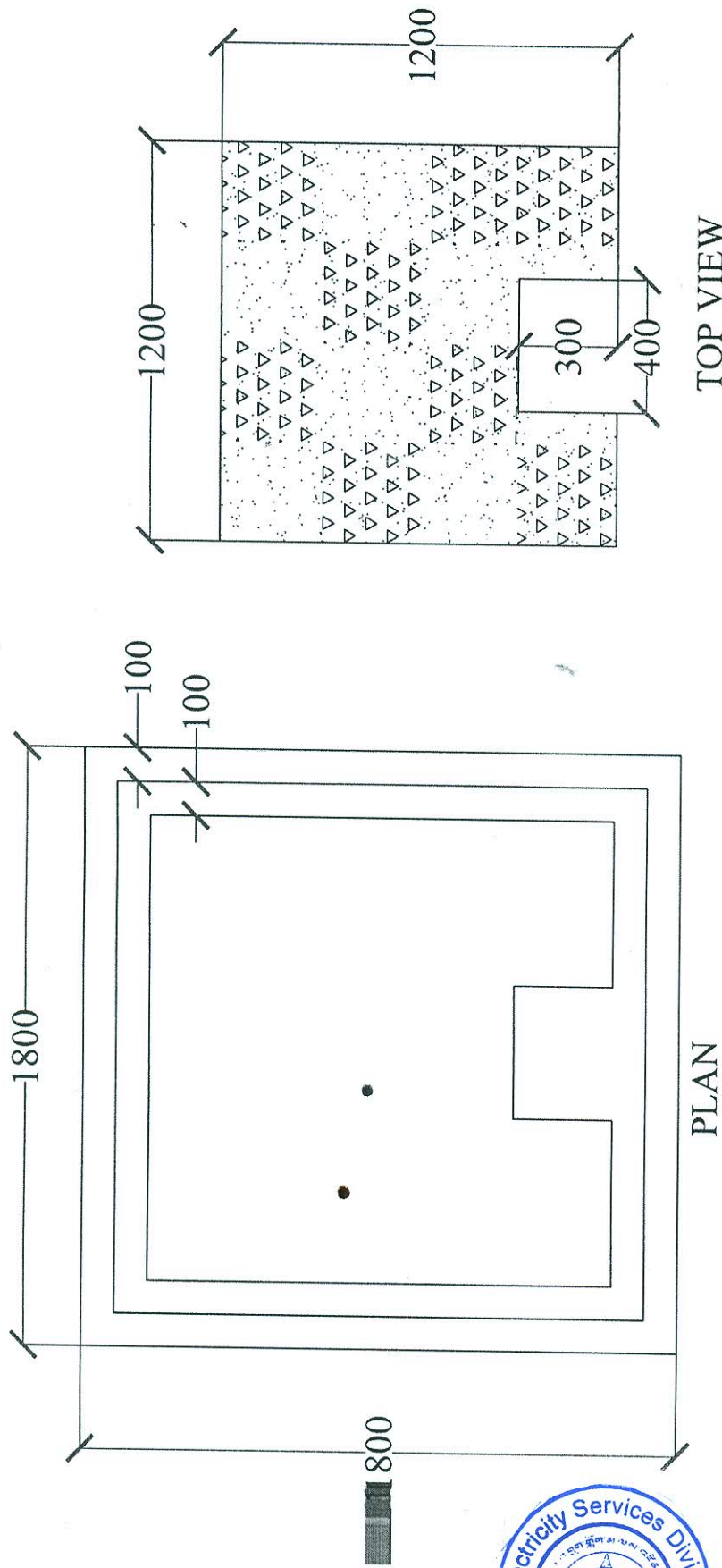

Figure:2 Details of MS Angle post 50x50x6 mm and MS flat 50x6 mm



Transformer plinth foundation



ALL THE DIMENSION ARE IN MILLIMETERS.

BHUTAN POWER CORPORATION LTD

FOUNDATION OF TRANSFORMER PLINTH

DRAWING NO. BPC-DSCD-01

REVISION



DESIGNATION	NAME	DATE
RAFPERSON		
ESIGNER		
PROJECT MANAGER		
HEAD OF DEPARTMENT		

CIRCULAR ARRANGEMENT

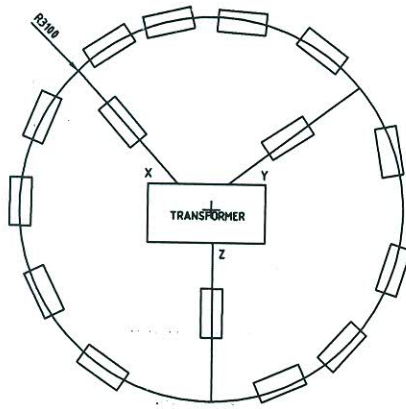

RECTANGULAR ARRANGEMENT

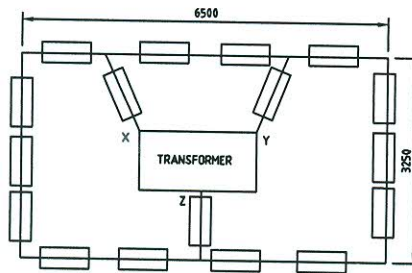

TRIANGULAR ARRANGEMENT

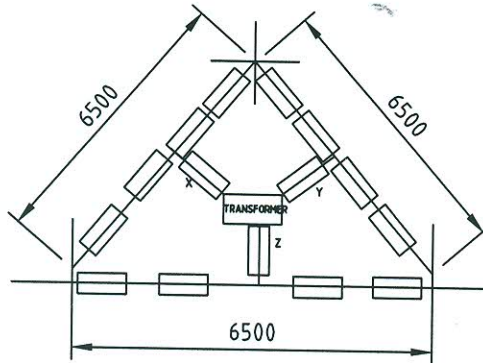

NOTES

1. THE CONNECTIONS POINTS SHOULD BE AS FOLLOWS:
 - a. TO ONE OF THE EARTH POINTS ON EITHER SIDE OF DOUBLE POLE STRUCTURE (X-Y)
ONE DIRECT CONNECTION FROM THREE, 33kV OR 11kV LIGHTNING ARRESTERS, AND TRANSFORMER TANK
 - b. TO EACH OF THE REMAINING TWO EARTH POINTS
 - (i) ONE SEPARATE CONNECTION FROM THE NEUTRAL OF THE LOW VOLTAGE SIDE OF THE TRANSFORMER.
 - (ii) ONE SEPARATE CONNECTION FROM THE TRANSFORMER AND THE HANDLE OF 33kV/11kV AB SWITCH.
 - (iii) ONE SEPARATE CONNECTION FROM THE EARTH TERMINAL OF THE POLES.
2. 25 x 6 mm GALVANISED IRON STRAP LEADS.
3. REFER DWG BPC-DCS-019 FOR EARTH POINTS ON TRANSFORMER AND STRUCTURE.

 BHUTAN POWER CORPORATION LIMITED		
DESIGNATION	NAME	DATE
DRAFTSPERSON		
DESIGNER		
PROJECT MANAGER		
HEAD OF DEPARTMENT		

ENGINEERING DESIGN & CONTRACTS DEPARTMENT
 TITLE : DISTRIBUTION DESIGN & CONSTRUCTION STANDARD
 INDICATIVE ARRANGEMENT OF GEE SLAB EARTHING
 DISTRIBUTION SUBSTATION

DRAWING NO. BPC-DDCS-2014-516

REVISION
2014



SAMPLE BILL OF QUANTITIES



BoQ for Material

Name of works: **LV Extension (RE-Fillin) at Samdrup Jongkhar**

Sl #	Material No	Description	Unit	Qty
1	523	Steel tubular pole 7.5 mtr long	NO	89
2	174	LV ABC Conductor for 2c-50 sq. mm	KM	2.836
3	178	LV ABC Conductor for 4c-50 sq. mm	KM	2.362
6	552	Stay sets assembly	SET	84
7	490	G. I. stay wire 7/8 SWG.	M	714
8	541	Stay clamp assembly	NO	84
9	251	Set of terminal caps for 50 sqmm	SET	37
11	256	Strain clamps / Dead End Clamp for 4c - 50 sq.mm LV ABC	NO	40
12	254	Strain clamps / Dead End Clamp for 2c - 50 sq.mm LV ABC	NO	46
15	288	Insulation tension jointing sleeves for 50 sq.mm	NO	38
18	245	Hook Bolt Assembly for LV ABC	SET	132
22	301	Suspension clamp - large angle for 4c - 50 sq.mm LV ABC	NO	-
23	302	Suspension clamp - small angle for 4c - 50 sq.mm LV ABC	NO	-
28	299	Suspension clamp - large angle for 2c - 50 sq.mm LV ABC	NO	16
29	300	Suspension clamp - small angle for 2c - 50 sq.mm LV ABC	NO	14
30	270	Insulation piercing connector (IPC 50/50)	NO	104
31	108	UnArm. Cu Cable 2Cx10sqmm PVC Insulated	M	1410
32	273	IPC 50-10 sqmm	NO	
33	260	Service dead end for 2c, 10 sqmm	NO	94
34	658	RCCB 20A, 2 pole	NO	0
35	659	ELCB 25 Amps, SP	NO	0
36		Single Phase Energy Meter (10-60 A)	NO	47



Name of works: LV Extension(RE-Fillin) at Samdrupcholing

Sl #	Material No	Description	Unit	Quantity
1	523	Steel tubular pole 7.5 mtr long	NO	81
2	174	LV ABC Conductor for 2c-50 sq. mm	KM	2.284
3	178	LV ABC Conductor for 4c-50 sq. mm	KM	1.673
6	552	Stay sets assembly	SET	69
7	490	G. I. stay wire 7/8 SWG.	M	552
8	541	Stay clamp assembly	NO	69
9	251	Set of terminal caps for 50 sqmm	SET	43
11	256	Strain clamps / Dead End Clamp for 4c - 50 sq.mm LV ABC	NO	42
12	254	Strain clamps / Dead End Clamp for 2c - 50 sq.mm LV ABC	NO	28
15	288	Insulation tension jointing sleeves for 50 sq.mm	NO	34
18	245	Hook Bolt Assembly for LV ABC	SET	108
22	301	Suspension clamp - large angle for 4c - 50 sq.mm LV ABC	NO	-
23	302	Suspension clamp - small angle for 4c - 50 sq.mm LV ABC	NO	29
28	299	Suspension clamp - large angle for 2c - 50 sq.mm LV ABC	NO	-
29	300	Suspension clamp - small angle for 2c - 50 sq.mm LV ABC	NO	3
30	270	Insulation piercing connector (IPC 50/50)	NO	92
31	108	UnArm. Cu Cable 2Cx10sqmm PVC Insulated	M	1080
32	273	IPC 50-10 sqmm	NO	72
33	260	Service dead end for 2c, 10 sqmm	NO	36
34	658	RCCB 20A, 2 pole	NO	0
35	659	ELCB 25 Amps, SP	NO	0
36		Single Phase Energy Meter (10-60 A)	NO	36



Name of works: LV Extension (RE-Fillin) at Jomotsangkha

Sl #	Material No	Description	Unit	Quantity
1	523	Steel tubular pole 7.5 mtr long	NO	83
2	174	LV ABC Conductor for 2c-50 sq. mm	KM	2.610
3	178	LV ABC Conductor for 4c-50 sq. mm	KM	2.700
6	552	Stay sets assembly	SET	90
7	490	G. I. stay wire 7/8 SWG.	M	720
8	541	Stay clamp assembly	NO	90
9	251	Set of terminal caps for 50 sqmm	SET	64
11	256	Strain clamps / Dead End Clamp for 4c - 50 sq.mm LV ABC	NO	72
12	254	Strain clamps / Dead End Clamp for 2c - 50 sq.mm LV ABC	NO	46
15	288	Insulation tension jointing sleeves for 50 sq.mm	NO	80
18	245	Hook Bolt Assembly for LV ABC	SET	125
22	301	Suspension clamp - large angle for 4c - 50 sq.mm LV ABC	NO	5
23	302	Suspension clamp - small angle for 4c - 50 sq.mm LV ABC	NO	28
28	299	Suspension clamp - large angle for 2c - 50 sq.mm LV ABC	NO	3
29	300	Suspension clamp - small angle for 2c - 50 sq.mm LV ABC	NO	22
30	270	Insulation piercing connector (IPC 50/50)	NO	108
31	108	UnArm. Cu Cable 2Cx10sqmm PVC Insulated	M	1260
32	273	IPC 50-10 sqmm	NO	84
33	260	Service dead end for 2c, 10 sqmm	NO	42
34	658	RCCB 20A, 2 pole	NO	0
35	659	ELCB 25 Amps, SP	NO	0
36		Single Phase Energy Meter (10-60 A)	NO	42



