

# **BHUTAN POWER CORPORATION LIMITED**

*(An ISO 9001:2015, ISO 14001:2015 & OHSAS 18001:2007 Certified Company)*

*(Registered Office, Thimphu)*

**DISTRIBUTION & CUSTOMER SERVICES DEPARTMENT**

**ELECTRICITY SERVICES DIVISION**

**WANGDUE: BHUTAN**



**TENDER NO. BPC/ESD/WAE/PMU-08(VOL-I)/2k21/02**

Dated 18<sup>th</sup> February 2021

**BIDDING DOCUMENT**

**FOR LABOUR CONTRACT OF**

- a. Right of Way (RoW) Clearing of Distribution Lines & Casting of Poles at Wangdue Dzongkhag.
- b. Construction works associated with extension of LT line in and around Wangdue Dzongkhag.

February 2021



# CONTENTS

1. Integrity Pact
2. Section I - Invitation for Bids
3. Section II - Instructions to Bidders
4. Section III – Bid Data Sheet
5. Section IV – Bidder information Sheet and Qualification criteria
6. Section V – General Conditions of Contract
7. Section VI – Special Conditions of Contract
8. Section VII - Technical Specifications
9. Section VIII - Price Schedules
10. Section IX - Bid Form
11. Section X - Sample Forms
12. Section XI - Drawings



# INTEGRITY PACT



## INTEGRITY PACT

### 1 General:

Whereas, Dill Kumar Rasaily, FSD, BPC Wangdue  
representing the Bhutan Power Corporation Limited, Royal Government of Bhutan,  
hereinafter referred to as the "Employer" on one part, and  
(Name of  
bidder or his/her authorized representative, with power of attorney) representing  
M/s. (Name of Firm)  
as the other part hereby execute this agreement as follows:

This agreement should be a part of the tender document, which shall be signed by both the parties at the time of purchase of bidding documents and submitted along with the tender document. This IP is applicable only to "Small" scale works, goods and services, the threshold of which will be announced by the government from time to time. The signing of the IP shall not apply to framework contracting such as annual office supplies etc.

### 2 Objectives:

Whereas, the Employer and the Bidder agree to enter into this agreement, hereinafter referred to as IP, to avoid all forms of corruption or deceptive practice by following a system that is fair, transparent and free from any influence/unprejudiced dealings in the **bidding process**<sup>1</sup> and **contract administration**<sup>2</sup>, with a view to:-

- 2.1 Enabling the Employer to obtain the desired contract at a reasonable and competitive price in conformity to the defined specifications of the works, goods or services; and
- 2.2 Enabling bidders to abstain from bribing or any corrupt practice in order to secure the contract by providing assurance to them that their competitors will also refrain from bribing and other corrupt practices

### 3. Scope

The validity of this IP shall cover the bidding process and contract administration period.

### 4. Commitments of the Employer:

The Employer Commits itself to the following:-

- 4.1 The Employer hereby undertakes that no official of the Employer, connected directly or indirectly with the contract, will demand, take a promise for or accept, directly or through intermediaries, any bribe, consideration, gift, reward, favor or any material or immaterial benefit or any other advantage from the Bidder, either for themselves or for any person, organization or third

<sup>1</sup> Bidding process, for the purpose of this IP, shall mean the procedures covering tendering process starting from bid preparation, bid submission, bid processing, and bid evaluation.

<sup>2</sup> Contract Administration, for the purpose of this IP, shall mean contract award, contract implementation, un-authorized sub-contracting and contract handing/taking over.

party related to the contract in exchange for an advantage in the bidding process and contract administration.

- 4.2 The Employer further confirms that its officials has not favored any prospective bidder in any form that could afford an undue advantage to that particular bidder in the bidding process and contract administration and will treat all Bidders alike.
- 4.3 Officials of the Employer, who may have observed or noticed or have reasonable suspicion shall report to the head of the employing agency or an appropriate government office any violation or attempted violation of clauses 4.1 and 4.2.
- 4.4 Following report on violation of clauses 4.1 and 4.2 by official (s), through any source, necessary disciplinary proceedings, or any other action as deemed fit, including criminal proceedings shall be initiated by the Employer and such a person shall be debarred from further dealings related to the bidding process and contract administration.

## **5 Commitments of Bidders:**

The Bidder commits himself/herself to take all measures necessary to prevent corrupt practices, unfair means and illegal activities during any stage of the bidding process and contract administration in order to secure the contract or in furtherance to secure it and in particular commits himself/herself to the following :-

- 5.1 The Bidder shall not offer, directly or through intermediaries, any bribe, gift, consideration, reward, favor, any material or immaterial benefit or other advantage, commission, fees, brokerage or inducement to any official of the Employer, connected directly or indirectly with the bidding process and contract administration, or to any person, organization or third party related to the contract in exchange for any advantage in the bidding process and contract administration.
- 5.2 The Bidder shall not collude with other parties interested in the contract to manipulate in whatsoever form or manner, the bidding process and contract administration.
- 5.3 If the bidder(s) have observed or noticed or have reasonable suspicion that the provisions of the IP have been violated by the procuring agency or other bidders, the bidder shall report such violations to the head of the procuring agency.

## **6 Sanctions for Violation:**

The breach of any of the aforesaid provisions shall result in administrative charges or penal actions as per the relevant rules and laws.

- 6.1 The breach of the IP or commission of any offence (forgery, providing false information, mis-representation, providing false/fake documents, bid rigging, bid steering or coercion) by the Bidder, or any one employed by him, or acting on his/her behalf (whether with or without the knowledge of the Bidder), shall

be dealt with as per the terms and conditions of the contract and other provisions of the relevant laws including De-barment Rules.

6.2 The breach of the IP or commission of any offence by the officials of the procuring agency shall be dealt with as per rules and laws of the land in vogue.

**7. Monitoring and Administration:**

7.1 The respective procuring agency shall be responsible for administration and monitoring of the IP as per the relevant laws.

7.2 The bidder shall have the right to appeal as per the arbitration mechanism contained in the relevant rules.

We, hereby declare that we have read and understood the clauses of this agreement and shall abide by it.

The parties hereby sign this Integrity Pact at \_\_\_\_\_ on \_\_\_\_\_



Affix  
Legal  
Stamp

EMPLOYER

BIDDER/REPRESENTATIVE

CID:

CID:

Witness: \_\_\_\_\_

Witness: \_\_\_\_\_

Name: Tashi Kezang

Name: \_\_\_\_\_

CID: 12008000688

CID: \_\_\_\_\_

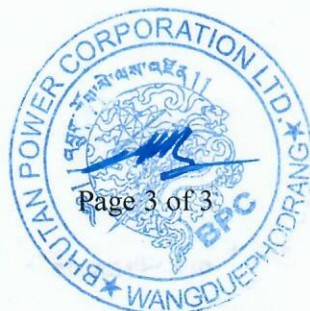

# Section I

# INVITATION FOR BIDS



**SECTION I  
INVITATION FOR BIDS**

Date: February 18, 2021

Tender No.: **BPC/ESD/WAE/PMU-08(Vol-I)/2k21/02**

1. BPC invites sealed bids from the below mentioned Class categories of Bhutanese National with W4 (Power and Telecommunications) valid License and registered with the Construction Development Board for the works as mentioned below:

**A: Right of Way (RoW) Clearing of Distribution Lines and casting of poles at Wangdue Dzongkhag.**

Sl no	Description	Name of Package	Estimated amount (Nu) in million	Bid Security (Nu)	Contract Class	Time for completion (Duration)
1	Wangdue-phodrang	Package A	1.6	32000	Small	6 months

**B: Construction works associated with extension of LV ABC lines in and around Wangdue Dzongkhag**

Sl no	Description	Name of Package	Estimated amount (Nu) in million	Bid Security (Nu) in million	Contract Class	Time for completion (Duration)
1	Wangdue-phodrang	Package B	0.65	13000	Small	6 months

2. Interested eligible Bhutanese National Contractors may obtain further information on the bid form and inspect the bidding documents at the office of:

**Sr. Divisional Manager  
Electricity Services Division  
Bhutan Power Corporation Limited  
Wangdue: Bhutan  
Telephone No. : +975-2-481282  
Mobile No. : +975 17975737**

3. A complete set of bidding document may be purchased by any interested eligible bidder upon submission of an appropriate written application to the address above and upon payment of a non-refundable fee of **Nu. 1000** (Ngultrum one thousand only) together with copies of valid trade license and CDB's registration certificate.
4. The prospective bidders can also download the Bidding documents for free from BPC website, [www.bpc.bt](http://www.bpc.bt). However, the bidders who have downloaded and printed the bidding documents by themselves should register with Electricity Services Division, BPC Wangdue, on or before the closing of bid sale date with written application together with valid trade license and CDB registration certificate. The bidders should bind the downloaded and printed document properly.
5. As per the prerequisite of Royal Government of Bhutan, all interested bidders must complete signing the Integrity Pact (IP) with Sr. Divisional Manager, Electricity Services, BPC, **Wangdue** at the time of purchase of bidding document. In order to sign the IP, the prospective bidders should accompany a witnesses along with one legal stamp.

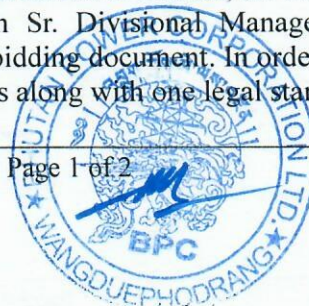



Invitation for Bids

---

Bid must be accompanied by Bid Security amount indicated against the individual package in Bhutanese Ngultrum (Nu.), and must be delivered in accordance with the Instructions to Bidders on the date indicated in the Bidding Documents. The date of sale of documents shall be from 19<sup>th</sup> February to 19<sup>th</sup> March 2021 and last date of SUBMISSION if document is on 19<sup>th</sup> March 2021 on or before 02:30 PM and will be publicly open at 3:00 PM on the same date.

6. BPC will not be responsible for any expenses incurred by bidders in connection with the preparation or delivery of bids.



**(Sr. Divisional Manager)**

Senior Divisional Manager  
Electricity Services Division  
Bhutan Power Corporation Limited  
Wangduephodrang



# Section II

## INSTRUCTIONS TO BIDDERS



## Contents

<b>Section 1: Instructions to Bidder (ITB)</b> .....	<b>2</b>
<b>A. General</b> .....	<b>2</b>
1. Scope of Tender.....	2
2. Corrupt Fraudulent Collusive or Coercive Practices .....	2
3. Eligible Bidders.....	3
4. Site Visit.....	3
<b>B. Content of Bidding Document</b> .....	<b>3</b>
5. Contents of Bidding Documents .....	3
6. Clarification of Bidding Documents .....	4
7. Amendment of Bidding Documents .....	4
<b>C. Preparation of Bids</b> .....	<b>4</b>
8. One Bid per Bidder .....	4
9. Bid Preparation Costs .....	4
10. Language of Bid .....	4
11. Documents comprising the Bid .....	4
13. Alternative Bid .....	5
14. Bid Price and Discount.....	5
15. Currencies of Bid and Payment.....	5
16. Documents comprising the Technical Proposal.....	5
17. Documents establishing the Qualification of the Bidder .....	5
18. Bid Validity .....	5
20. Format and Signing of Bid .....	6
<b>D. Submission and Opening of Bids</b> .....	<b>6</b>
21. Sealing and Marking of Bids .....	6
22. Bid Submission Deadline.....	7
23. Late Bids.....	7
24. Modification, Substitution or Withdrawal of Bids.....	7
25. Bid Opening .....	7
<b>E. Tender Opening and Evaluation</b> .....	<b>7</b>
26. Confidentiality .....	7
27. Clarification .....	8
28. Bidder: Contacting the Employer.....	8
29. Determination of Responsiveness .....	8
30. Non Conformities, Errors and Omissions.....	8
31. Evaluation and Comparison of Tenders.....	8
32. Employer's Right to Accept or Reject any or all .....	9
<b>F. Contract Award</b> .....	<b>9</b>
33. Award Criteria.....	9
34. Letter of intent to Award the contract/Notification of Award.....	9
35. Complaints .....	10



## Section 1: Instructions to Bidder (ITB)

### A. General

1. Scope of Tender	<p>1.1 The Employer, as <b>indicated in the BDS</b> issues this Bidding Document for the procurement of Works as specified in Section 6 (Employer's requirement): The name, identification and identification of this bidding are <b>provided in the BDS</b>.</p> <p>1.2 The successful Bidder will be required to complete the Works within the Time for Completion stated in the Special Conditions of Contract (SCC).</p> <p>1.3 Throughout this Bidding Documents;</p> <ul style="list-style-type: none"><li>(a) The term "in writing means communicated in written form with proof of receipt;</li><li>(b) If the context so requires, singular means plural and vice versa; and</li><li>(c) "day" means calendar day.</li></ul>
2. Corrupt Fraudulent Collusive or Coercive Practices	<p>2.1 The Royal Government of Bhutan requires that Employers and the Bidders shall observe the highest standard of ethics during the implementation of procurement proceedings and the execution of Contracts under public funds.</p> <p>2.2 In pursuance of this requirement, the Employer shall</p> <ul style="list-style-type: none"><li>(a) exclude the bidder from participation in the procurement proceeding concerned or reject a proposal for award; and</li><li>(b) declare a bidder ineligible, either indefinitely or for a stated period of time, from participation in procurement proceedings under public funds;</li></ul> <p>2.3 If it, at any time, determines that the bidder has engaged in corrupt, fraudulent, collusive or coercive practices in competing for, or in executing, a Contract under the public funds.</p> <p>2.4 The Government defines, for the purposes of this provision, the terms set forth below as follows :</p> <ul style="list-style-type: none"><li>a) "<b>corrupt practice</b>"<sup>1</sup> is the offering, giving, receiving or soliciting, directly or indirectly, of anything of value to influence improperly the actions of another party;</li><li>b) "<b>fraudulent practice</b>"<sup>2</sup> is any intentional act or omission including</li></ul>

<sup>1</sup> 'Another party' refers to a public official acting in relation to the procurement process or contract execution.

<sup>2</sup> A 'party' refers to a public official; the term 'benefit' and 'obligation' relate to the procurement process or contract execution; and the 'act or omission' is intended to influence the procurement process or contract execution.

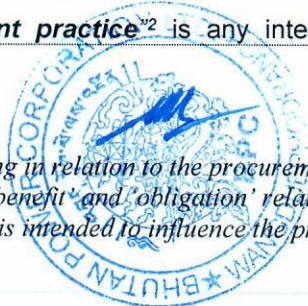

	<p>misrepresentation, that knowingly or recklessly misleads, or attempts to mislead, a party to obtain a financial or other benefits or to avoid an obligation;</p> <p>c) <b>“collusive practice”</b><sup>3</sup> is an arrangement between two or more parties designed to achieve an improper purpose, including to influence improperly the actions of another party;</p> <p>d) <b>“coercive practice”</b><sup>4</sup> is impairing or harming or threatening to impair or harm, directly or indirectly, any party or the property of the party to influence improperly the actions of a party.</p> <p>2.5 The bidder shall be aware of the provisions on fraud and corruption stated in GCC Clause 3 and GCC Sub-Clause 34.2(d).</p> <p>2.6 The RGoB requires that the Employer’s personnel have an equal obligation not to solicit, ask for and/or use coercive methods to obtain personal benefits in connection with the said proceedings.</p>
3. Eligible Bidders	<p>3.1 Bidders of the categories <b>specified in the BDS</b> are eligible to participate in this bidding process.</p> <p>3.2 The Employer shall invite Bids using the Open Tendering Method (National Competitive Bidding) or limited tender as applicable.</p> <p>3.3 The bidder shall meet the qualification requirement stated in the BDS</p>
4. Site Visit	<p>4.1 The Bidders, at their own responsibility and risk, is encouraged to visit and examine the Site and obtain all information that may be necessary for preparing the bid and entering into a Contract for performance of the Works. The costs of visiting the Site shall be at the bidder’s own expense.</p>
<h2>B. Content of Bidding Document</h2>	
5. Contents of Bidding Documents	<p>5.1 The sections comprising the Bidding Document are listed below and should be read in conjunction with any Amendment issued in accordance with ITB Clause 7:</p> <p style="text-align: center;"><b>PART 1 Bidding Procedures</b></p> <ul style="list-style-type: none"> <li>• Section 1: Instructions to Bidders (ITB)</li> <li>• Section 2: Bidding Data Sheet (BDS)</li> <li>• Section 3: Evaluation and Qualification Criteria</li> <li>• Section 4: Bidding forms</li> <li>• Section 5: General Conditions of Contract (GCC)</li> <li>• Section 6: Special Conditions of Contract (SCC)</li> <li>• Section 7: Contract Forms</li> <li>• Section 8: Bill of Quantities &amp; Specifications</li> <li>• Section 9: Drawings</li> </ul> <p>5.2 The Employer is not responsible for the completeness of the Bidding Document and their Addenda, if they were not obtained directly from the</p>

<sup>3</sup> ‘parties’ refers to participations in the procurement process including public officials attempting to establish bid prices at artificial, non competitive levels.

<sup>4</sup> A ‘party’ refers to a participant in the procurement in the procurement process or contract execution.



	<p>source stated by the Employer in the Invitation for Bids.</p> <p>5.3 The Bidder is expected to examine all instructions, forms terms, and specifications in the Bidding Documents. Failure to furnish all information or documentation required by the Bidding Documents may result in the rejection of the bid.</p>
6. Clarification of Bidding Documents	6.1 A prospective Bidder requiring any clarification of the Bidding Document shall contact the Employer in writing at the Employer's address <b>indicated in the BDS.</b>
7. Amendment of Bidding Documents	7.1 At any time prior to the deadline for submission of Bid, the Employer may amend the Bidding Document by issuing addenda and extend the deadline for the submission of bids at its discretion. Any amendment issued shall become an integral part of the Bidding Document and shall be communicated in writing to all those who have purchased the Bidding Document.
<b>C. Preparation of Bids</b>	
8. One Bid per Bidder	8.1 A Bidder shall submit only one (1) Bid. A Bidder who submits or participates in more than one (1) Bid shall cause all the proposals with the Bidder's participation to be disqualified.
9. Bid Preparation Costs	9.1 The Bidder shall bear all costs associated with the preparation and submission of its Bids, and the Employer shall in no case be responsible or liable for those costs, regardless of the conduct or outcome of the Bidding process.
10. Language of Bid	10.1 All documents relating to the Bid shall be in the language specified in the BDS.
11. Documents comprising the Bid	<p>11.1 The original and copy(ies) of Bid submitted by the Bidder shall comprise the following:</p> <ul style="list-style-type: none"> <li>(a) The Bid form (in the format indicated in Section IV – Forms of Bid, Qualification Information, Letter of Acceptance, and Contract);</li> <li>(b) License and certificate</li> <li>(c) Bid Security in accordance with Clause 19;</li> <li>(d) Priced Bill of Quantities;</li> <li>(e) and any other materials required to be completed and submitted by Bidders, as specified in the BDS.</li> </ul> <p>11.2 The Instruction to Bidders, Bidding Data Sheet, General Conditions of Contract, Special Conditions of Contract, Specifications and drawings are for the information of the bidders and is not required to be submitted by the bidder,</p>

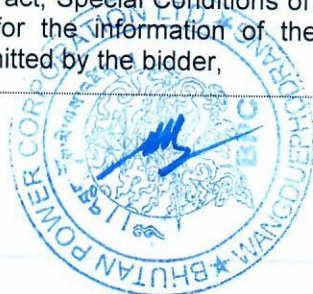

12 Letter of Bid and Schedule	12.1	The letter of Bid, Schedules, and all documents listed under Clause 11, shall be prepared using the relevant forms in Section 4 (Bidding Forms), if so provided in BDS. The forms must be completed without any alterations to the text, and no substitutes shall be accepted. All blank spaces shall be filled in with the information requested.
13. Alternative Bid	13.1	Alternative Bid shall not be considered in small works.
14. Bid Price and Discount	14.1	The prices and discounts quoted by the Bidder in the Letter of Bid and in the Schedules shall confirm to the requirements specified below;
	14.2	The bidder shall submit a bid for the whole of the works described in ITB 1.1 by filling in prices for all items of the Works, as identified in Section 4, Bidding Forms. In case of admeasurements contracts, the Bidder shall fill in rates and prices for all items of the Works described in the Bill of Quantities. Items against which no rate or price is entered by the Bidder will not be paid for by the Employer when executed and shall be deemed covered by the rates for other items and prices in the Bill of Quantities.
	14.3	The Bid price shall take into account the cost of materials, transportation, labour, taxes, levies, overheads and profit and any other cost. The Bid price shall be fixed for the duration of performance of the Contract and shall not be subject to any adjustment on any account. The Bid price shall be applicable for the whole works described in the Drawings, Specifications and Schedule of Works.
15 Currencies of Bid and Payment	15.1	All prices shall be quoted in Bhutanese Ngultrum (BTN) and shall be paid in BTN.
16 Documents comprising the Technical Proposal	16.1	The bidder shall furnish a work plan in simple bar chart and other information if provided in BDS, to demonstrate the adequacy of the Bidders' proposal to meet the work requirements and the completion time.
17 Documents establishing the Qualification of the Bidder	17.1	To establish its qualification to perform the Contract in accordance with Section 3 (Evaluation and Qualification Criteria) the Bidder shall provide the information requested in the corresponding information sheets included in Section 4 (Bidding Forms)
18 Bid Validity	18.1	Bids shall remain valid for the period <b>specified in the BDS</b> . Any Bids which does not meet the validity requirement as per the BDS shall be rejected by the Employer as non-responsive.
19 Bid Security	19.1	The Bidder shall at their option furnish, as part of the Bid, a Bid Security as <b>specified in the BDS</b> issued by any reputed Financial Institutions in Bhutan and shall be valid thirty (30) days beyond the Bid validity period. <ul style="list-style-type: none"> <li>a) Unconditional Bank Guarantee;</li> <li>b) A demand Draft; or</li> </ul>

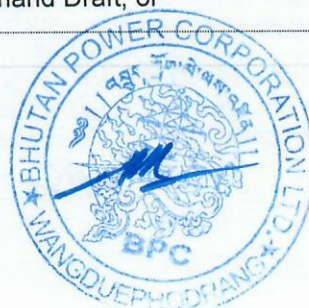

	<p style="text-align: center;">c) Cash Warrant</p> <p>19.2 In exceptional circumstances, prior to the expiration of the Bid validity period, the Employer may solicit the Bidder's consent to an extension of the Bid validity period. The request and responses shall be made in writing. The validity of Bid Security shall be suitably extended promptly.</p> <p>19.3 The Bid Security may be forfeited:</p> <ul style="list-style-type: none"> <li>(a) if the Bidder withdraws the Bid after Bid opening during the period of Bid validity. Further the bidder may be excluded from future participation for a period of two years.</li> <li>(b) if the Bidder does not accept the correction of the Bid price, pursuant to clause 31; or</li> <li>(c) in the case of a successful Bidder, if the Bidder fails within the specified time limit to sign the Agreement; or furnish the required Performance Security.</li> </ul>
<p>20 Format and Signing of Bid</p>	<p>20.1 The Bidder shall prepare one (1) original of the documents comprising the Bid as described in ITB Clause 11 and clearly mark it "ORIGINAL." In addition, the Bidder shall prepare the number of copies of the Bid, as specified in the BDS and clearly mark each of them "COPY." In the event of any discrepancy between the original and the copies, the original shall prevail.</p> <p>20.2 The original and each copy of the Bid shall be typed or written in indelible ink and shall be signed by the person duly authorized to sign on behalf of the Bidder.</p> <p>20.3 Any interlineations, erasures, or overwriting shall be valid only if they are signed or initialled by the person(s) signing the Bid.</p>
<h3>D. Submission and Opening of Bids</h3>	
<p>21 Sealing and Marking of Bids</p>	<p>21.1 The Bidder shall enclose the original in one (1) envelope and all the copies of the bid in another envelope, duly marking the envelopes as "ORIGINAL" and "COPY." These two (2) envelopes shall then be enclosed in one (1) single outer envelope.</p> <p>21.2 The inner envelopes shall:</p> <ul style="list-style-type: none"> <li>(a) Be signed across the seals by the person authorised to sign the Bid on behalf of the Bidder;</li> <li>(b) Be marked "ORIGINAL" and " COPY" and</li> <li>(c) Bear the name and address of the Bidder.</li> </ul> <p>21.3 The outer envelope shall;</p> <ul style="list-style-type: none"> <li>(a) Be sealed with adhesive or other sealant to prevent reopening;</li> </ul> <p>21.4 be addressed to the Employer at the address specified in the BDS; bear a statement "DO NOT OPEN BEFORE....." the time and date for Bid opening as specified in the BDS.</p> <p>21.5 If all or any envelopes are not sealed and marked as required by ITB Sub-Clause 21, the Employer <b>shall not reject the bids but assume no responsibility for the misplacement or premature opening of the Bid.</b></p>

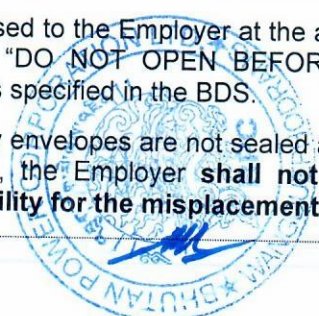



22 Bid Submission Deadline	<p>22.1 Bids must be received by the Employer at the address and no later than the date and time <b>specified in the BDS.</b></p> <p>22.2 Bids may be hand delivered, posted by registered mail or sent by courier.</p> <p>22.2 The Employer may, at its discretion, extend the deadline for the submission of Bids by amending the Bidding Document in accordance with ITB Clause 7, in which case all rights and obligations of the Employer and Bidders previously subject to the deadline shall thereafter be subject to the new deadline as extended.</p>
23 Late Bids	23.1 Late bids shall not be considered and shall be returned unopened
24 Modification, Substitution or Withdrawal of Bids	24.1 A Bidder may modify, substitute or withdraw their Bids after it has been submitted by sending a written notice before the deadline for submission of Bids.
25 Bid Opening	<p>25.1 The Employer shall open the Bids in the presence of the bidders who is attending the bid opening, including modifications or substitutions made pursuant to ITB Clause 24. Bidders or their representatives shall be allowed to attend and witness the bid opening and shall sign a register evidencing their attendance.</p> <p>25.2 The name of the Bidder, Bid modifications, substitutions or withdrawals, total amount of each Bid, number of corrections, discounts, and the presence or absence of requisite Bid Security, and such other details as the Employer, at its discretion, may consider appropriate, shall be read out aloud and recorded.</p> <p>25.3 The Employer shall prepare minutes of the Bid opening. The minutes shall include, as a minimum, the name of the Bidders and whether there has been a withdrawal, substitution or modification; the Bid Price including any discounts and the presence or absence of a Bid Security, if one was required.</p> <p>25.4 Bids not opened and read out at the Bid opening shall not be considered, irrespective of the circumstances, and shall be returned unopened to the Bidder.</p>
<b>E. Tender Opening and Evaluation</b>	
26 Confidentiality	26.1 After the opening of Bids, information relating to the examination, clarification, and evaluation of Bids and recommendations for award shall not be disclosed to Bidders or other persons not officially concerned with the evaluation process until after the award of the Contract is announced.



27 Clarification	27.1 The Employer may ask Bidders for clarification of their Bids in order to facilitate the examination and evaluation of Bids. The request for clarification and the response shall be in writing, and any changes in the prices or substance of the Bid shall not be sought, offered or permitted, except to confirm the correction of arithmetical errors discovered by the Employer in the evaluation of the Bids, in accordance with ITB Clause 31.
28 Bidder: Contacting the Employer	28.1 Following the opening of Bids and until the Contract is signed no Bidder shall make any unsolicited communication to the Employer or try in any way to influence the Employer's examination and evaluation of Bids which may result in the rejection of bids. If any Bidder wishes to contact the Employer on any matter related to the Bidding process, it should do so in writing
29 Determination of Responsiveness	<p>29.1 Prior to detailed evaluation of bids, the employer shall determine whether each bid (a) meets the eligibility criteria defined in ITB clause 3; (b) has been properly signed; (c) is accompanied by the bid security; and (d) is substantially responsive to the requirements of the bidding documents.</p> <p>29.2 A substantially responsive Bid is one that conforms in all respects to the requirements of the Bidding Document without material deviation, reservation or omission. A material deviation, reservation or omission is one that:</p> <ul style="list-style-type: none"> <li>(a) affects in any substantial way the scope, quality, or performance of the Works specified in the Contract; or</li> <li>(b) limits in any substantial way, or is inconsistent with the Bid Document, the Employer's rights or the Bidder's obligations under the Contract; or</li> <li>(c) if rectified would unfairly affect the competitive position of other Bidders presenting substantially responsive Bids.</li> </ul> <p>29.3 If a Bid is not substantially responsive to the Bidding Document it shall be rejected by the Employer and shall not subsequently be made responsive by the Bidder by correction of the material deviation, reservation or omission.</p> <p>29.4 There shall be no requirement as to the minimum number of responsive Bids.</p>
30 Non Conformities, Errors and Omissions	30.1 The Employer may regard a Bid as responsive even if it contains minor deviations that do not materially alter or depart from the characteristics, terms, conditions and other requirement set forth in the Bidding Document or if it contains errors or oversights that are capable of being corrected without affecting the substance of the Bid.
31 Evaluation and Comparison of Tenders	<p>31.1 The Employer shall evaluate and compare only those Bids determined to be substantially responsive to the requirements of the Bidding Document. Substantially responsive Bids are those which fulfil the requirements of ITB Clauses 11 and 12.</p> <p>31.2 The evaluation will take into account corrected Bid Price and discounts (if</p>

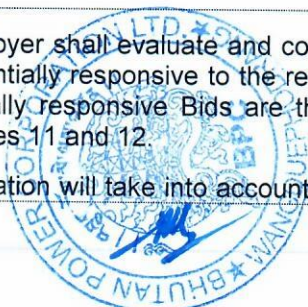

	<p>any).</p> <p>31.3 The Employer will check substantially responsive Bids for any arithmetical errors. Where there is a discrepancy between the amounts in figures and words, the amount in words will govern. If a Bidder refuses to accept the correction, its Bids shall be rejected. The Employer shall correct arithmetical errors on the following basis:</p> <p>(a) if there is a discrepancy between the unit price and the line item total, the unit price shall prevail and the total price shall be corrected, unless in the opinion of the Employer there is an obvious misplacement of the decimal point in the unit price, in which case the total price, as quoted, shall govern and the unit price shall be corrected; and</p>
32. Employer's Right to Accept or Reject any or all	32.1 The Employer reserves the right to accept any Bid, to annul the Bid proceedings, or to reject any or all Bids, at any time prior to Contract award, without thereby incurring any liability to Bidders, or any obligation to inform Bidders of the grounds for the Employer's actions.
<b>F. Contract Award</b>	
33. Award Criteria	33.1 The Employer shall award the Contract to the Bidders whose offer is substantially responsive to the Bidding Document and that has been determined to be the lowest evaluated Bid, provided that the Bidder is determined to be qualified to perform the Contract satisfactorily
34. Letter of Intent to Award the Contract/ Notification of Award	<p>34.1 The Employer shall notify the concerned Bidder whose bid has been selected in accordance with ITB 33.1 in writing (in the format in Section 4-hereafter called the "Letter of Intent to Award) that the Employer has intention to accept its bid and the information regarding the name, address and amount of selected bidder shall be given to all other bidders who submitted the bid. Such notification should be communicated in writing, including by cable, facsimile, telex or electronic mail to all the bidders on the same day of dispatch. The Employer shall ensure that the same information is uploaded on their website on the same day of dispatch.</p> <p>34.2 If no bidder submits an application pursuant to ITB 35 within a period of five <b>(5) working days</b> of the notice provided under ITB 34.1, Prior to the expiration of the period of Bid validity, the Employer shall notify the successful Bidder, in writing that its Bid has been accepted. Until a formal contract is prepared and executed, the <b>Notification of Award</b> shall constitute a binding Contract.</p> <p>34.3 Within <b>five (5) working days</b> of the receipt of the Notification of Award from the Employer, the successful Bidder shall furnish the Performance Security, in the amount specified in the BDS</p> <p>34.4 The proceeds of the performance security shall be payable to the Employer unconditionally upon first written demand as compensation for any loss resulting from the Contractor's failure to complete its obligations under the Contract.</p>



	<p>34.5 Within <b>five (5) working days</b> of receipt of the notification of award, the successful Bidder shall sign, date and return it to the Employer.</p>
<p>35. Complaints</p>	<p>35.1 The Bidder shall submit the complaint in writing within ten (10) days from the date of letter of intent to award the contract pursuant to ITB 34.1 to the Employer.</p> <p>35.2 The Bidder may appeal to the Independent Review Body only if the Employer has not delivered the decision within the specified time, or the complainant is not satisfied with the decision of the Employer in accordance with rules and procedures of Independent Review Body.</p>



# Section III

## BID DATA SHEET



## Section 3 - Bidding Data Sheet

Instructions for completing the Bidding Data Sheet are provided, as needed, in the notes in italics mentioned for the relevant ITB Clauses

ITB Clause	Amendment of, and Supplements to, Clauses in the Instructions to Bidders
------------	--

### A. General

ITB 1.1	The Employer is <i>[Sr. Divisional Manager, Electricity Services Division, Bhutan Power Corporation Limited, Wangdue]</i>
---------	---

	The Name and Identification of the Contract is/are <i>[Labor Contract for RoW clearing of Distribution lines &amp; casting of poles at Wangdue and extension of LT line in and around Wangdue Dzongkhag]</i>
--	--

	The Works are <i>[Package A: RoW clearing and casting of pole; Package B: Extension of LT line]</i>
--	---

ITB 3.2	<i>[Choose option A or B, whichever is applicable, and delete the other option].</i>
---------	--

	<b>Option A: Limited Bidding method:</b>
--	--

	The Invitation for Bid is open to all Bidders enlisted with <i>[name of Dzongkhag]</i> .
--	--

	<b>Option B: Open Tendering method</b>
--	--

	All Bidders regardless of whether enlisted or not enlisted with the Dzongkhag may submit Bids provided they otherwise qualify.
--	--

ITB 3.3	The evaluation shall be based on the lowest price of the responsive bidder and the work will awarded to the lowest responsive bidder. <i>[Generally the selection is based on the lowest price. If there is a specific project need basic minimum technical qualification requirement should specified here]</i>
---------	--

ITB 4.1	<b>Site Visit:</b> The contractor should visit the site along with the officials from the concerned divisions before submission of document. The concerned division shall issue site visit certificate for concurrence. The employer shall not be responsible if there are abnormal prices either due to not visiting the site or error in the bidder's estimation. Sample of Site visit certificate is enclosed in Sample forms.
---------	---

### B. Bidding Documents

ITB 6.1	For <b>clarification of Tenders purposes</b> only, the Employer's address is:
---------	---

	Attention: <i>[Sr. Divisional Manager, ESD, BPC, Wangdue]</i>
--	---

	Address: <i>[ Sr. Divisional Manager, ESD, BPC, Wangdue]</i>
--	--

	Telephone: <i>[ +975-2-481282]</i>
--	------------------------------------

	Electronic mail address: <i>[esdwangdue@bpc.bt]</i>
--	---



## C. Preparation of Bids

ITB 16.1	A simple bar chart is <i>not required</i> [delete which is not appropriate]																
ITB 18.1	The Bid validity period shall be [90] days up to <b>June 17, 2021</b> . [normally be minimum of 90 days for Works of such a simple nature]																
ITB 19.1	<p>A Bid Security in the amount shall be as below, in the form;</p> <p><b>A: Right of Way (RoW) Clearing of Distribution Lines and casting of poles.</b></p> <table border="1" style="width: 100%; border-collapse: collapse;"> <thead> <tr> <th style="width: 5%;">Sl no</th> <th style="width: 35%;">Description</th> <th style="width: 30%;">Name of Package</th> <th style="width: 30%;">Bid Security (Nu)</th> </tr> </thead> <tbody> <tr> <td style="text-align: center;">1</td> <td>Wangdue</td> <td style="text-align: center;">Package A</td> <td style="text-align: right;">32,000.00</td> </tr> </tbody> </table> <p><b>B: Construction works associated with extension of LT lines.</b></p> <table border="1" style="width: 100%; border-collapse: collapse;"> <thead> <tr> <th style="width: 5%;">Sl no</th> <th style="width: 35%;">Description</th> <th style="width: 30%;">Name of Package</th> <th style="width: 30%;">Bid Security (Nu)</th> </tr> </thead> <tbody> <tr> <td style="text-align: center;">1</td> <td>Wangdue</td> <td style="text-align: center;">Package B</td> <td style="text-align: right;">13,000.00</td> </tr> </tbody> </table> <p>a) Unconditional Bank guarantee b) Cash warrant; or c) Demand draft</p> <p>The Bidder shall at their option furnish, as part of the Bid, a Bid Security as specified in the BDS issued by any reputed Financial Institutions in Bhutan and shall be valid thirty (30) days beyond the Bid validity period, (i.e., 17<sup>th</sup> July 2021). If the bid security validity does not meet the required date, the bid shall be treated as non-responsive.</p>	Sl no	Description	Name of Package	Bid Security (Nu)	1	Wangdue	Package A	32,000.00	Sl no	Description	Name of Package	Bid Security (Nu)	1	Wangdue	Package B	13,000.00
Sl no	Description	Name of Package	Bid Security (Nu)														
1	Wangdue	Package A	32,000.00														
Sl no	Description	Name of Package	Bid Security (Nu)														
1	Wangdue	Package B	13,000.00														
ITB 20.1	In addition to the original, [one] copies shall be submitted. [Usually one copy but procuring agencies may asked more if required].																

## D. Submission and Opening of Bids

ITB 21.2	The inner and outer envelopes shall bear the following additional identification marks: [indicate any markings that are required on inner and outer envelopes]
ITB 22.1	<p>For <b><u>Bid submission purposes</u></b> only, the Employer's address is: Attention: Sr. Divisional Manager, ESD, BPC, Wangdue Address: ESD, BPC, Wangdue</p> <p>The deadline for the submission of Tenders is: Time &amp; Date 2:30 PM on 19th March 2021</p>
ITB 25.1	<p>The Bid opening shall take place on the same day as the closing day of the bid submission at: <i>Conference hall, ESD, BPC, Wangdue.</i></p> <p>Date: [19/03/2021]; Time:[3:00 PM]</p>

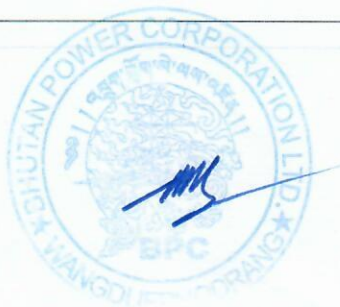

## F. Award of Contract

<b>ITB 33.1</b>	The Employer shall award the Contract to the Bidders whose offer is substantially responsive to the Bidding Document and that has been determined to be the lowest evaluated Bid, provided that the bidder is determined to be qualified to perform the Contract satisfactory.
<b>ITB 34.3</b>	The amount of Performance Security shall be [10%] percent of the Contract Price. <i>[It should be equal to ten (10) percent of the Contract Price of the Works].</i> <b>Differential Amount:</b> The contractor shall provide differential security in the form of cash warrant separately if the quoted amount of any bidders is 20% lower than BPC's estimate.





# Section IV

## BIDDER INFORMATION SHEET



# Standard Form: Qualification Information

Notes on Form of Qualification Information: The following information is to be filled in by bidders which will be used for purposes of evaluation

## 1. Individual bidders

1.1 Constitution of legal status of Bidder [attach copy]

Place of registration: \_\_\_\_\_

Principal place of business: \_\_\_\_\_

Power of attorney of signatory of Bid [attach]

1.2 Qualifications and experience of key personnel proposed for administration and execution of the Contract. Refer BDS. The supporting documents such detailed CVs signed in original supported by certificates for qualification and experience.

Position	Name	Qualification & year of experience (general)	Year of experience in proposed position	Remarks
Supervisor				



Section V

**GENERAL CONDITION OF  
CONTRACT**



## Section V. General Conditions of Contract

<p>1. Definitions</p>	<p>1.1 The following words and expressions shall have the meaning hereby assigned to them. Boldface type is used to identify the defined terms:</p> <ul style="list-style-type: none"> <li>(a) <b>Completion Certificate</b> means the Certificate issued by the Employer as evidence that the Contractor has executed the Works in all respects as per drawing, specifications, and Conditions of Contract.</li> <li>(b) The <b>Completion Date</b> is the date of completion of the Works as certified by the Engineer, in accordance with GCC Clause 18.</li> <li>(c) <b>Contract</b> means the Agreement entered into between the Employer and the Contractor to execute, complete and maintain the Works.</li> <li>(d) <b>Contractor</b> means the person or corporate body whose Tender to carry out the Works has been accepted by the Employer and is named as such in the SCC.</li> <li>(e) <b>Contract Price</b> is the price stated in the Letter of Acceptance and thereafter as adjusted in accordance with the provisions of the Contract. The <b>Contractor's Bid</b> is the completed Bid Document including the priced offer submitted by the Contractor to the Employer.</li> <li>(f) <b>Days</b> mean calendar days.</li> <li>(g) A <b>Defect</b> is any part of the Works not completed in accordance with the Contract.</li> <li>(h) The <b>Employer</b> is the party named in the SCC who employs the Contractor to carry out the Works.</li> <li>(i) The <b>Engineer</b> is the person named in the SCC, who is responsible for supervising the execution of the works and administering the Contract.</li> <li>(j) The <b>Intended Completion Date</b> is the date specified in the SCC on which the Contractor shall complete the Works and may be revised if extension of time or an acceleration order is issued by the Engineer.</li> <li>(k) The <b>Site</b> is the area defined as such in the SCC.</li> <li>(l) The <b>Works</b> are what the Contract requires the Contractor to construct, install, and hand over to the Employer, as defined in the SCC.</li> </ul>
<p>2. Interpretation &amp; Documents forming the Contract</p>	<p>2.1 In interpreting the GCC, singular also means plural, male also means female or neuter, and the other way around. Headings in the GCC shall not be deemed part thereof or be taken into consideration in the interpretation or construance of the Contract. Words have their normal meaning under the language of the Contract unless specifically defined.</p> <p>2.2 The following documents forming the Contract shall be interpreted in</p>



	<p>the following order of priority:</p> <ul style="list-style-type: none"> <li>(a) The signed Contract Agreement.</li> <li>(b) The letter of Notification of Award.</li> <li>(c) The completed Bid form as submitted by the Bidder.</li> <li>(d) The Special Conditions of Contract.</li> <li>(e) The General Conditions of Contract.</li> <li>(f) The Specifications</li> <li>(g) The Drawings.</li> <li>(h) Any other document listed in the PCC as forming part of the Contract.</li> </ul>
<p>3. Corrupt, Fraudulent, Collusive or Coercive Practices</p>	<p>3.1 The BPC requires that Employers, as well as Contractors shall observe the highest standard of ethics during the implementation of procurement proceedings and the execution of Contracts under public funds.</p> <p>3.2 In pursuance of this requirement, the Employer shall</p> <ul style="list-style-type: none"> <li>(a) exclude the Contractor from participation in the procurement proceedings concerned or reject a proposal for award; and</li> <li>(b) declare a Contractor ineligible, either indefinitely or for a stated period of time, from participation in procurement proceedings under public fund;</li> </ul> <p>3.3 The Government defines, for the purposes of this provision, the terms set forth below as follows:</p> <ul style="list-style-type: none"> <li>(a) "corrupt practice"<sup>1</sup> is the offering, giving, receiving or soliciting, directly or indirectly, of anything of value<sup>2</sup> to influence improperly the actions of another party;</li> <li>(b) "fraudulent practice"<sup>3</sup> is any intentional act or omission, including a misrepresentation, that knowingly or recklessly misleads, or attempts to mislead, a party to obtain a financial or other benefit or to avoid an obligation;</li> <li>(c) "collusive practice"<sup>4</sup> is an arrangement between two or more parties designed to achieve an improper purpose, including to influence improperly the actions of another party; and</li> <li>(d) "coercive practice"<sup>5</sup> is impairing or harming, or threatening to</li> </ul>

<sup>1</sup> "another party" refers to a public official acting in relation to the procurement process or contract execution. In this context, "public official" includes staff and employees of any organizations (including any institutions providing finance for the Works) taking or reviewing procurement decisions.

<sup>2</sup> "anything of value" includes, but is not limited to, any gift, loan, fee, commission, valuable security or other asset or interest in an asset; any office, employment or contract; any payment, discharge or liquidation of any loan, obligation or other liability whatsoever, whether in whole or in part; any other services, favour or advantage, including protection from any penalty or disability incurred or apprehended or from any action or proceeding of a disciplinary or penal nature, whether or not already instituted and including the exercise or the forbearance from the exercise of any right or any official power or duty.

<sup>3</sup> a "party" refers to a public official; the terms "benefit" and "obligation" relate to the procurement process or contract execution; and the "act or omission" is intended to influence the procurement process or contract execution.

<sup>4</sup> "parties" refers to participants in the procurement process (including public officials) and an "improper purpose" includes attempting to establish bid prices at artificial, non competitive levels.

<sup>5</sup> a "party" refers to a participant in the procurement process or contract execution.

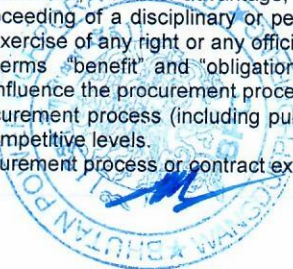

	<p>impair or harm, directly or indirectly, any party or the property of the party to influence improperly the actions of a party.</p> <p>3.4 The Government requires that the Client's personnel have an equal obligation not to solicit, ask for and/or use coercive methods to obtain personal benefits in connection with the said proceedings.</p>
4. Governing Language and Law	4.1 The Contract as well as all correspondence and documents relating to the Contract exchanged by the Contractor and the Employer, shall be written in English unless otherwise stated in the SCC. The Contract shall be governed by and interpreted in accordance with the laws of the Kingdom of Bhutan.
5. Engineer's Decision	5.1 Except where otherwise specifically stated in the SCC, the Engineer will decide Contractual matters between the Employer and the Contractor in the role as representative of the Employer.
6. Delegation	6.1 The Engineer may delegate any of his duties and responsibilities to his representative, after notifying the Contractor, and may cancel any delegation, without retroactivity, after notifying the Contractor.
7. Communications and Notices	7.1 Communications between Parties pursuant to the Contract shall be in writing to the address specified in the SCC. A notice shall be effective when delivered or on the notice's effective date, whichever is later.
8. Sub- Contracting	8.1 The Contractor shall not be permitted to subcontract any part of the Works in whole or in part.
9. Contractor's Personnel	9.1 The Contractor shall employ the key personnel named in the Schedule of Key Personnel, as referred to in the SCC, to carry out the functions stated in the Schedule, or other personnel approved by the Engineer.
10. Welfare of Labourers & Child Labour	<p>10.1 The Contractor shall provide proper accommodation to his labourers and arrange proper water supply, conservancy and sanitation arrangements at the site in accordance with relevant regulations, rules and orders of the government.</p> <p>10.2 The Contractor shall comply with the applicable minimum age, labour laws and requirements of (including applicable treaties which have been ratified by) the Government of Bhutan regarding hazardous forms of child labour.</p>



<p>11. Safety, Security and Protection of the Environment</p>	<p>11.1 The Contractor shall throughout the execution and completion of the Works and the remedying of any defects therein :</p> <p>(a) have full regard for the safety of all persons entitled to be upon the Site and keep the Site and the Works in an orderly state;</p> <p>(b) provide and maintain at the Contractors own cost all lights, guards, fencing, warning signs and watching for the protection of the Works or for the safety on-site; and</p> <p>(c) take all reasonable steps to protect the environment on and off the Site and to avoid damage or nuisance to persons or to property of the public or others resulting from pollution, noise or other causes arising as a consequence of the Contractors methods of operation.</p>
<p>12. Access to the Site</p>	<p>12.1 The Contractor shall allow the Engineer and any person authorised by the Engineer access to the Site and to any place where work in connection with the Contract is being carried out or is intended to be carried out.</p>
<p>13. Documents, Information.</p>	<p>13.1 The Contractor shall furnish to the Engineer all information, schedules, calculations and supporting documentation that may be requested of it.</p>
<p>14. Property</p>	<p>14.1 If the contract is terminated by the Employer because of the contractors default, then, the contractor shall not be allowed to remove any materials on the Site, Plant, and Temporary Works until the matter is amicably resolved.</p>
<p>15. Insurance</p>	<p>15.1 The Contractor shall provide insurance as stated in the SCC</p> <p>15.2 The Contractor shall deliver policies and certificates of insurance to the Engineer, for the Engineer's approval, before the Start Date.</p> <p>15.3 If the Contractor does not provide any of the policies and certificates required, the Employer may effect the insurance which the Contractor should have provided and recover the premiums the Employer has paid from payments otherwise due to the Contractor or, if no payment is due, the payment of the premiums shall be a debt due.</p>
<p>16. Possession of the Site</p>	<p>16.1 The Employer shall give possession of the Site, or parts of the Site, to the Contractor on the date(s) specified in the SCC.</p>
<p>17. Commencement of Works</p>	<p>17.1 The Contractor may commence execution of the Works on the Start Date, or other such date as specified in the SCC, and shall carry out the Works in an expeditious manner.</p> <p>17.2 If the Contractor fails to commence the works within the above stated period, the Employer may, at his sole discretion, terminate the Contract and forfeit the Performance Security, if any.</p>
<p>18. Completion of Works</p>	<p>18.1 The Contractor shall complete the Works within the number of days stated in the SCC from the date of commencing the Works on the Site.</p>

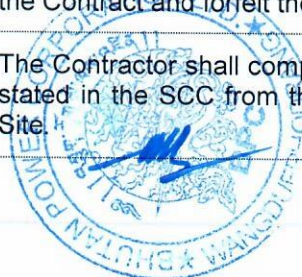

19. Programme of Works	19.1 Within the time stated in the SCC, the Contractor shall submit to the Engineer for approval a work program. The Contractor shall submit to the Engineer for approval an updated Programme at intervals no longer than the period stated in the SCC.
20. Early Warning	20.1 The Contractor shall warn the Engineer at the earliest opportunity of specific likely future events or circumstances that may adversely affect the quality of the work result in increase to the Contract Price or delay in the execution of the Works.
21. Compensation Events	<p>21.1 The following shall be Compensation Events:</p> <p>(a) the Employer does not give access to the Site or part of the Site by the Site Possession Date stated in the SCC; and</p> <p>(b) if the payment is delayed pursuant to Clause 25.1.</p> <p>21.2 If a Compensation Event would prevent the work being completed before the Intended Completion Date, the Intended Completion Date shall be extended, as appropriate, by the Engineer.</p>
22. Non-Scheduled Items of Works	22.1 The Contractor shall be paid for non-scheduled items of works only when the Engineer approves such works and at the rates and in the manner stated in the SCC.
23. Schedule of Works	<p>23.1 The Schedule of Works will contain rates for all items for the construction including temporary works, installation, testing, and commissioning work to be done by the Contractor.</p> <p>23.2 The Contractor shall be paid for the quantity of the work done at the rate in the Contract Agreement for each item.</p> <p>23.3 The Contractor shall be entirely responsible for all taxes, duties, license fees, and other such levies imposed outside and inside Bhutan.</p>
24. Payment Certificates	<p>24.1 The Contractor shall submit to the Engineer monthly statements of the estimated value of the work executed less the cumulative amount certified previously. The Engineer shall check the Contractor's monthly statement and certify the amount to be paid to the Contractor.</p> <p>24.2 The value of work executed shall be determined by the Engineer.</p> <p>24.3 The value of work executed shall comprise the value of the quantities of the items in the Schedule of Works completed.</p> <p>24.4 The value of work executed shall include the valuation of Variations, Certified Dayworks and Compensation Events.</p> <p>24.5 The Engineer may exclude any item certified in previous certificates or reduce the proportion of any item previously certified in any certificate in the light of later information.</p>
25. Payments and Currency	<p>25.1 The Employer shall pay the Contractor the amounts certified by the Engineer within thirty (30) days of the date of each certificate.</p> <p>25.2 The Employer shall make Advance Payment (mobilization and secured advance) to the Contractor of the amounts and by the</p>





		<p>dates stated in the SCC against provision by the Contractor of an unconditional Bank Guarantee, (Form 4).</p> <p>25.3 The Contractor is to use the advance payment only to pay for Equipment, Plant, Materials, and mobilisation expenses required specifically for the execution of the Contract. The Contractor shall demonstrate that the advance payment has been used in this way by submitting copies of invoices or other documents to the Employer.</p> <p>25.4 The advance payment shall be repaid by deducting proportionate amounts from payments otherwise due to the Contractor, following the schedule of completed percentages of the Works on a payment basis. No account shall be taken of the advance payment or its repayment in assessing valuations of work done, variations, claims or any amount payable due to failure to complete the works.</p>
26. Retention	<p>26.1 The Employer shall retain from each payment due to the Contractor the proportion stated in the SCC until the completion of the whole of the Works.</p> <p>26.2 On completion of the whole of the Works, half the total amount retained shall be repaid to the Contractor, the remaining half when the Defects Liability Period has passed and the Engineer has certified that all Defects notified by the Engineer to the Contractor before the end of this period have been corrected.</p>	
27. Liquidated Damages	27.1	The Contractor shall pay liquidated damages to the Employer at the rate per day stated in the SCC for each day that the Completion Date is later than the Intended Completion date for the works or for any part thereof.
28. Performance Security	28.1	Upon Notification of Award, a Performance Security shall be provided to the Employer in the amount and form stated in the Contract Forms (Form 3). The Performance Security shall be valid until a date thirty (30) days from the date of issue of the Certificate of Completion.
29. Price Adjustment	29.1	The rates and prices in the bill of quantities are fixed for the duration of the Contract and not subject to price adjustment during the performance of the Contract.
30. Completion	30.1	The Contractor shall request the Engineer to issue a Certificate of Completion of the Works, and the Engineer will do so upon deciding that the work is substantially completed.
31. Correction of Defects	<p>31.1 The Engineer shall give notice to the Contractor of any Defects before the end of the Defects Liability Period, which begins at Completion, and is defined in the SCC. The Defects Liability Period shall be extended for as long as the Defects remain to be corrected.</p> <p>31.2 If the Contractor has not corrected a Defect within the time specified in the Engineer's notice, the Engineer will assess the cost of having the Defect corrected, and the Contractor will pay this amount.</p>	
32. Taking Over	32.1	The Employer shall take over the Site and the Works within seven

	(7) days of the Engineer issuing a Certificate of Completion.
33. Final Account	<p>33.1 The Contractor shall supply the Engineer a detailed account of the total amount that the Contractor considers payable under the Contract. The Engineer shall certify any final payment that is due to the Contractor within twenty-one (21) days of receiving the Contractor's account if it is correct and complete.</p> <p>33.2 The Employer shall effect payment of the final account within thirty (30) days from the date of certification by the Engineer.</p>
34. Termination	<p>34.1 The Employer or the Contractor by giving thirty (30) days written notice of default to the other party, may terminate the Contract in whole or in part if the other party causes a fundamental breach of Contract.</p> <p>34.2 Fundamental breaches of the Contract shall include, but shall not be limited to, the following:</p> <ul style="list-style-type: none"> <li>(a) the Contractor stops work for more than thirty (30) days when no stoppage of work is shown on the current Programme and the stoppage has not been authorised by the Engineer;</li> <li>(b) the Engineer gives notice that failure to correct a particular defect is a fundamental breach of Contract and the Contractor fails to correct it within a reasonable period of time determined by the Engineer;</li> <li>(c) the Contractor has delayed the completion of the Works by the number of days for which the maximum amount of Liquidated Damages can be paid;</li> <li>(d) the Contractor, in the judgment of the Employer, has engaged in corrupt or fraudulent practices, as defined in GCC Clause 3, in competing for or in executing the Contract; and</li> <li>(e) a payment certified by the Engineer is not paid to the Contractor by the Employer within sixty (60) days of the date of the Engineer's certificate.</li> </ul> <p>34.3 The Employer and the Contractor may at any time terminate the Contract by giving notice to the other party if either of the parties becomes bankrupt or otherwise insolvent. In such event, termination will be without compensation to any party provided that such termination will not prejudice or affect any right of action or remedy that has accrued or will accrue to the other party.</p> <p>34.4 Notwithstanding the above, the Employer may terminate the Contract for convenience.</p> <p>34.5 If the Contract is terminated, the Contractor is to stop work immediately, make the Site safe and secure and hand over the Site to the Employer as soon as reasonably possible.</p>



<p>35. Payment upon Termination</p>	<p>35.1 If the Contract is terminated because of a fundamental breach of Contract by the Contractor, the Engineer shall issue a certificate for the value of the work done and Plant and Materials ordered less advance payments received up to the date of the issue of the certificate and less the percentage to apply to the value of the work not completed, as indicated in the SCC.. Additional Liquidated Damages shall not apply. If the total amount due to the Employer exceeds any payment due to the Contractor, the difference shall be a debt payable to the Employer.</p> <p>35.2 If the Contract is terminated for the Employer's convenience or because of a fundamental breach of Contract by the Employer, the Contractor shall be entitled to payments for completed works and the materials that have been brought to the site for the purpose of the works, but not used as certified by the Engineer after adjusting any payments received by the Contractor.</p>
<p>36. Release from Performance</p>	<p>36.1 If the Contract is frustrated by the outbreak of war or by any other event entirely outside the control of either the Employer or the Contractor, the Engineer shall certify that the Contract has been frustrated. The Contractor shall make the Site safe and stop work as quickly as possible, after receiving this certificate. The Contractor shall be paid for all works carried out before stoppage of work and any work carried out afterwards to which a commitment was made.</p>
<p>37. Force Majeure</p>	<p>37.1 For the purposes of this Contract, "Force Majeure" means an exceptional event or circumstance:</p> <ul style="list-style-type: none"> <li>(a) which is beyond a Party's control,</li> <li>(b) which such Party could not reasonably have provided against before entering into the Contract,</li> <li>(c) which, having arisen, such Party could not reasonably have avoided or overcome, and</li> <li>(d) which is not substantially attributable to the other Party.</li> </ul> <p>37.2 Force Majeure may include, but is not limited to, exceptional events or circumstances of the kind listed below, so long as conditions (a) to (d) above are satisfied:</p> <ul style="list-style-type: none"> <li>(a) war, hostilities (whether war be declared or not), invasion, act of foreign enemies,</li> <li>(b) rebellion, terrorism, sabotage by persons other than the Contractor's Personnel, revolution, insurrection, military or usurped power, or civil war,</li> <li>(c) riot, commotion, disorder, strike or lockout by persons other than the Contractor's Personnel,</li> <li>(d) munitions of war, explosive materials, ionizing radiation or contamination by radio-activity, except as may be attributable to the Contractor's use of such munitions, explosives, radiation or radio-activity, and</li> <li>(e) natural catastrophes such as earthquake, hurricane, typhoon or volcanic activity.</li> </ul>



	<p>37.3 However, force majeure shall not include the following;</p> <ul style="list-style-type: none"> <li>i. rainfall</li> <li>ii. snowfall</li> <li>iii. strikes in other countries</li> <li>iv. non-availability of labourer and materials such as timbers, boulders, sand, and other materials</li> <li>v. difficulty and risky terrain and remoteness of site.</li> </ul>
<p>38. Settlement of Disputes</p>	<p>38.1 The Employer and the Contractor shall use their best efforts to settle amicably all disputes arising out of or in connection with this Contract or its interpretation.</p> <p>38.2 Any dispute between the parties to the Contract that may not be settled amicably will be referred to Arbitration at the initiative of either of the parties.</p> <p>38.3 The Arbitration shall be conducted in accordance with the Arbitration Rules of the Kingdom of Bhutan in force.</p>



Section VI  
SPECIAL CONDITION OF  
CONTRACT



## Section 6. Special Conditions of Contract

*Instructions for completing the Special Conditions of Contract are provided, as needed, in the notes in italics mentioned for the relevant GCC Clauses.3*

Clause Ref	Amendments of, and Supplements to, Clauses in the General Conditions of Contract
GCC 1.1(d)	The Contractor is <i>[name, address and name of authorised representative]</i> .
GCC 1.1(h)	The Employer is Electricity Services Division, BPC, Wangdue.
GCC 1.1(i)	The Engineer is Engineer <i>Tashi Kelzang, ESD, Wangdue.</i>
GCC 1.1(j)	The intended Completion Date for the whole of the Works shall be <b>6 (Six) months.</b>
GCC 1.1(k)	The Site is located at Wangdue Dzongkhag.
GCC 1.1(l)	The Works are Labour contract for RoW clearing and casting of poles, and extension of LT lines.
GCC 2.2	The additional documents forming part of this Contract are: <i>["No additional documents".]</i>
GCC 4.1	The Language governing the Contract shall be <i>[English]</i> <i>[usually English language].</i>
GCC 5.1	The Engineer shall obtain specific approval of the Employer before taking any of the following actions:
GCC 7.1	The addresses for Communications shall be: <u>For the Employer:</u> <i>[ESD, BPC, Wangdue]</i> <u>For the Contractor:</u> <i>[insert name, address and contact details].</i>
GCC 9.1	The Key Personnel of the Contractor are: <i>[Supervisor]</i>



GCC 11.1	<p><i>The Contractor shall assume full responsibility for the adequacy and safety of site operations while carrying out clearing of jungle/ bushes and cutting of trees near the power lines and he shall adopt measures to prevent injuries to persons or damage to properties of utilities. The Contractor shall hold the Employer harmless from any liability for loss or damage resulting from his failures to take the necessary precautions. The Contractor shall avoid undue interference with private business, public travel, or with the work of other Contractors. The Contractor shall take steps to protect the environment and to MINIMIZE NOISE, POLLUTION, FIREHAZARDS or any other undesirable effects resulting from his method of operation.</i></p> <p><b>The Contractor shall, throughout the execution and completion of the Works and the remedying of any defects therein:</b></p> <ul style="list-style-type: none"> <li>i. Take necessary precautions to avoid any electric hazards and put written request whenever line shutdown is required.</li> <li>ii. Provide necessary Personnel Protective Equipment's (PPE) to all the site staff and Compact have full regard for the safety of all persons under his control and ESD (BPC) shall not held any responsible for failure to put on required safety practice.</li> <li>iii. Provide and maintain at his own cost all lights, guards, fencing, warning signs and watching, when and where necessary or required by the Engineer/ Supervisor or by any duly constituted authority, for the protection of the Works or for the safety and convenience of the public and in view of general safety.</li> <li>iv. Take all reasonable steps to protect the environment on and off the Site and to avoid damage or nuisance to persons or to property of the public or other resulting from pollution, noise or other causes arising as a consequence of his method of operation.</li> <li>v. The O&amp;M In-charge shall ensure to deploy one Lineman to supervise the work continuously and issue work permit/ shutdown permit and ensure safe working environment as per O&amp;M manual 2012 till completion of the work.</li> <li>vi. Contractor shall arrange to cut/ clear all bushes, trees and debranching using necessary precautions and supports <b>(sag down is restricted)</b> in order to minimize damages to power infrastructures, government and private properties. Any damages due to sheer negligence, the party has to bear all the expenses that may incurred and compensate thereof.</li> <li>vii. Contractor shall maintain the height of bush/tree at 1ft/30cm from the ground level.</li> </ul>
GCC 15.1	For insurance purposes the type of cover required shall be: The contractor shall be responsible for the insurance <i>[modify as appropriate]</i>
GCC 16.1	Possession of the site shall be within [ 7 ] days from the date of signing of the Contract.
GCC 17.1	Commencement of work shall be within [ 7 ] days from the date of handing over possession of the Site.
GCC 18.1	Completion of works shall be within [ 6 ] Months from the date of commencing the works on the site.



GCC 19.1	The Contractor shall submit the first work plan [10] days after signing the Contract, and shall update the work plan every [4] weeks during the period of the Contract.
GCC 22.1	<i>[Enter here the agreed rates for non-scheduled items of work if known, if not known then make the statement "The rates for non-scheduled items of works shall be determined by the Engineer". NA</i>
GCC 25.2	An advance payment of [10] % of the Contract Price will be made to the Contractor within (14) days of Contract signing date. <i>[an advance payment is usually 10% of the contract price].</i>
GCC 26.1	The Retention shall be [10] % of the Contract Price. <b><u>However, for RoW clearing works, Retention money shall not be applicable.</u></b>
GCC 27.1	The liquidated damages for the whole of the Works are [0.10 %] per day. The maximum amount of liquidated damages for the whole of the Works is [10] percent of the initial Contract Price. <i>[usually, liquidated damages are set between 0.05 percent to 0.10 percent per day and the total amount is not to exceed 10 percent of the Contract Price.]</i>
GCC 31.1	The Defects Liability Period shall be [ One ] (Year).
GCC 35.1	The percentage to apply to the value of the work not completed, representing the Employer's additional cost for completing the Works, is [percent, it is generally 20% of the value of work not completed up to a maximum of 10% of the initial contract price]





# Section VII

## TECHNICAL SPECIFICATION



Table of Contents

1.	GENERAL .....	1
2.	CONSTRUCTION OF OVERHEAD 33 kV, 11 kV AND LOW VOLTAGE LINES .....	2
2.1	General .....	2
2.2	Distribution line voltages, locations and clearances .....	2
2.2.1	Standard voltage for distribution system: .....	2
2.2.2	Choice of route.....	2
2.2.3	Approval of Line Routes.....	3
2.2.6	Overhead Line Clearances .....	4
2.2.7	Road Crossings .....	4
2.3	Construction, Testing and Commissioning.....	5
2.3.1	Alignment of the line .....	5
2.3.2	Erection of supports .....	5
2.3.3	Erection of DP Structures for angle locations.....	6
2.3.4	Special Foundation in Unstable Soil.....	6
2.3.5	Anchoring and providing guys for supports .....	6
2.3.6	Fixing of cross arms and insulators .....	7
2.3.7	Laying of AAAC/HV ABC/LV ABC/ACSR Conductor .....	8
2.3.8	Mid span jointing of conductors .....	8
2.3.9	Sagging and Tensioning of conductors.....	8
2.3.10	Conductors Sag and Tension .....	10
2.3.11	Supports at Different Elevation .....	11
2.3.12	Good Conductor Stringing Work Practices .....	12
2.3.13	Earthing of Distribution Lines .....	13
2.3.14	Final Completion and Commissioning .....	14
3.	UNDERGROUND CABLE INSTALLATION.....	14
3.1	General Scope .....	14
3.2	Codes and Standards .....	14
3.3	Installation Work Scope.....	14
3.4	Earthing of Cables.....	21
3.5	Testing of Cables .....	22
4.	INSTALLATION OF DISTRIBUTION TRANSFORMER SUBSTATIONS .....	22
4.1	Selection of Site .....	22
4.2	Installation of PAD Mounted Distribution Transformers.....	22
4.3	Fencing Arrangement.....	23
4.4	Substation Earthing.....	23
4.5	Transportation and Handling of Transformers .....	24
4.6	Substation Structure and Earthing .....	25
4.7	Protection of distribution transformers .....	25
4.8	Installation of Distribution/Mini Pillars.....	26
4.9	Connection of Supply to Consumer's Premises.....	27
4.10	Consumer Metering .....	27
4.11	Direct Connected Metering.....	27
4.12	CT Metering.....	28
4.13	High Voltage Metering .....	28



**1. General**

All the works should be carried out strictly as per the Drawings, Specifications, etc. and as per the Contract document. Any modification/changes pertaining to the work should not be carried out without the prior written approval from the Employer. Any modification/changes done without the prior approval will be asked to be dismantled/demolished at the cost of the Contractor and the Employer will not be responsible for any cost whatsoever associated with the modification of works. All approval shall be in writing and no verbal approval will be entertained.

Prior to start of work, the Contractor is obliged to study the route and possible location of various poles, double pole, angle pole, transformers, etc. Any change in the route or modification should be at the approval of the Employer. The Scope of Works to be carried out under the Contract covers all the works associated with the:

- a) Construction, testing and commissioning of 33 kV (Three phase and Two Phase), 11kV (Three Phase and Two Phase) and LT lines (Three Phase and Single Phase) including line route finalization, transportation of materials from designated stores to the Work site, erection of poles, fixing of insulators, line stringing, clamping, earthing, erection of anti-climbing devices, danger plates, painting of poles, etc.
- b) Erection, testing and commissioning of distribution transformers including transportation of materials from designated Stores to sites, mounting of the transformers, distribution pillars, associated pole-top equipment like isolators, drop-out fuses, earthing work, etc.
- c) Clearing jungles/bushes, trees and removal of branches and disposal; felling of trees including cutting of trunks and branches, and removal;
- d) Materials required for the execution of the Contract shall be collected from the designated stores as specified under Article III, Clause 6 of Conditions of Contract.

**The Bidder shall note that supply of sand, stone chips, cement, bricks, HT tiles, PVC tape, Ampere Tape, Welding rods, Hack saw blades, marking cloth, nuts & bolt and Aluminium lugs, paints, thinner, charcoal and salt for earthing, GI pipes & HDPE pipes (as specified in BoQ), and other miscellaneous material required for the construction work is in the Bidder's Scope. Bidder shall also note that any excess materials procured by the Bidder for the construction works will not be taken by the Employer.**

The Bidder may contact the persons mentioned in Clause 3.3 of Section II- Instructions to Bidders, for detailed list of miscellaneous items required.

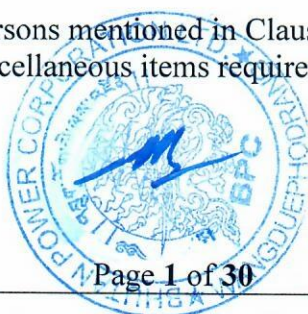

## Technical Specifications

---

The work shall be carried out with full diligence and in accordance with the general guidelines listed herein. It is imperative/mandatory that the workers and the Supervisors wear safety helmet, safety belts and other kits for their own safety.

The survey work shall be carried out in close coordination with the Employer's Engineer and the line route and the pole locations, angle points, etc. finalized and approved by the Employer's Engineer. All the works associated with the erection shall be carried out under the general supervision of the Employer's Engineer/Supervisor.

## **2. Construction of Overhead 33 kV, 11 kV and low voltage lines**

### **2.1 General**

This section covers the procedures to be adopted during the construction of 33kV lines, 11kV lines, low voltage lines etc. Before start of construction works, the persons in charge shall familiarize with the line route and acquaint themselves with the Local Rules, so that necessary provisions there-of may be adopted.

### **2.2 Distribution line voltages, locations and clearances**

#### **2.2.1 Standard voltage for distribution system:**

##### **Proposed Medium Voltage (MV) construction:**

33 kV Line (Three Phase, 3 wire)

11 kV Line (Three Phase, 3 wire)

##### **Proposed Low Voltage (LV) construction**

LV Line (Three phase, 4 wire, 415 Volts)

LV Line (Single phase, 2 wire, 240 Volts)

#### **2.2.2 Choice of route**

The route selected for the proposed overhead line should be the one that will give the lowest cost over the life of the line. Route selection therefore involves consideration of a number of factors, including the cost of landowner compensation, the cost of transporting materials to the site, construction cost and the cost of ongoing maintenance requirements including vegetation control. As a general rule, following parameters should be kept in mind:

- a. The shortest route practicable.
- b. As close as possible to the road for easy maintenance and approach during construction.
- c. Route in direction of possible future load.
- d. Angle point should be less.



## Technical Specifications

---

Where possible, line routes should avoid steep hills or valleys, swamps, lakes, thick forests, rivers or other locations where access is difficult or long spans are required. When building along a road, pole positions should not cause a traffic hazard or be in locations where there is a higher probability of vehicle impact.

The following should be avoided wherever possible:

- a) Areas likely to be used for future urban development;
- b) Routes incorporating sharp changes in line direction;
- c) Routes close to aerodromes;
- d) Religious monuments;
- e) Special trees of religious significance;
- f) School playgrounds;
- g) Cemeteries;
- h) Buildings containing explosives;
- i) Taking lines through individual/private plots/community forest; and
- j) Not considering the aesthetic of the land use.

No lines should be within 50ft distance from a National Highway.

### 2.2.3 Approval of Line Routes

Prior to the erection of lines along public roads, the authority responsible for the road should be contacted and approval obtained for the location of all poles, road crossings, tree cutting or trimming and guying locations. Where overhead distribution lines are to be constructed in urban areas, it will also be necessary to contact the local Town Planning Authority for approval. Where appropriate, approval should also be obtained from authorities such as the National Environment Commission, Department of Forestry, etc.

Once the line route is finalised, a detailed line survey should be undertaken and the pole locations finalized and marked. Poles should be located well clear of water and other areas of potential land subsidence. Poles for lines that cross-agricultural fields should, wherever possible, be located at bunds.

### 2.2.5 Tree clearances

The width for tree clearance will depend upon the voltage and the importance of the line concerned. No rigid limitations can be laid down. However, the following clearances may be adhered to, as far as possible.

Voltage	Comment
33 kV lines	The route should be cleared of all growth within 6 m on either side starting from the center of the line and, in addition, of trees that could fall and contact the line.
11 kV Lines	The route should be cleared of all growth within 4.5 m on

## Technical Specifications

	either side starting from the center of the line and, in addition, of trees that could fall and contact the line.
All ABC	Left to the discretion of the Supervisor. Aerial bundled conductor is insulated so contact with vegetation should not cause a fault. However, the route should be cleared so the risk of trees falling across the line is minimized.

### 2.2.6 Overhead Line Clearances

The following minimum clearances should be maintained.

Particulars	33 kV	11 kV	LV (bare conductor)	LV (ABC)
<b>Ground clearance</b>				
• Across street	6.1 m	6.1 m	5.8 m	5.5 m
• Elsewhere	5.8 m	5.8 m	5.5 m	4.5 m
<b>Separation between phases</b>				
• Horizontal	0.9 m	0.7 m	#	#
• Vertical	1.0 m	0.6 m	0.3 m	#
<b>Clearance from buildings</b>				
• Horizontal	1.8 m	1.2 m	1.2 m	#
• Vertical	3.7 m	3.7 m	2.5 m	#
<b>Sectional clearance</b>	2.8 m	2.6 m	#	#
<b>Safe working clearance (minimum)</b>	0.6 m	0.3 m	0.15 m	#

Notes: #: Not Applicable

The following minimum vertical separation of conductors should be maintained.

Particulars	Minimum Clearance
33 kV and 11 kV	1.2 m
33 kV and LV	1.5 m
11 kV and LV	1.2 m
33 kV or 11 kV and telephone line	1.8 m
LV and telephone line	0.6 m

### 2.2.7 Road Crossings

The road crossings should be as minimum as possible.

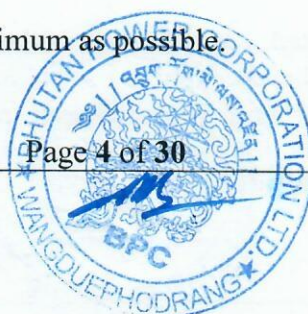

## **2.3 Construction, Testing and Commissioning**

The construction of overhead lines may be divided into the following parts:

- (i) Erection of supports.
- (ii) Providing guys to supports.
- (iii) Mounting cross-arms, pins and strain insulators.
- (iv) Stringing of line conductors.
- (v) Jointing of conductors.
- (vi) Sagging or tensioning of conductors.
- (vii) Earthing.
- (viii) Testing and commissioning.

The drawings/sketches may be referred, which give the details regarding phase to phase clearances, positioning of cross arms, pole top brackets, earth wire clamps, etc.

### **2.3.1 Alignment of the line**

A detailed route survey for the line has to be made and approval of the alignment of the line should be obtained by the Engineer before excavation of the pits. To the extent possible, alignment of lines shall be located along or close to existing roads and tracks. During alignment, the pole locations may be marked with pegs conspicuously and shall be located with adequate distance from water bodies. Also, the poles that pass through agricultural field, to the extent possible shall be located at the bunds.

### **2.3.2 Erection of supports**

After the final survey of the line and after marking of the pole locations with peg and approved by the Employer, excavation work has to be commenced. The pits for the supports are excavated in the direction of the line as this will facilitate the erection of support, in addition to giving greater lateral stability. The depth of the foundation to be excavated for poles shall be 1400 mm for 7.5 metre poles (LV), 1600 mm 9.0 metre (11 kV) poles and 1900mm for 10 metre (33kV) poles, while the area of the foundation will be 600x700mm.

Before the pole is put into the pit, a stone base of 100 mm thick shall be placed at the bottom of the pit. In lieu of 100 mm PCC base, base plate is being used. When the pole is erected inside the pit, wooden dead men may be utilized to facilitate lifting of the pole. Once planted into the pit, the pole should be kept in a vertical position with the help of ropes, using them as a temporary anchor.

As the poles are being erected, say from an anchor point to the next angle point, the alignment of the poles is to be checked and set right by visual check. The verticality of the poles are to be checked with a spirit level on both transverse and longitudinal directions. In case of LV lines, the holes for fixing hook bolts are also to be checked for facing proper direction.

Once the verticality and alignment are satisfactory, the pit shall be backfilled and compacted to a distance of 450 mm below ground level. A 500 x 500 mm concrete foundation shall then be constructed around the pole and extending to 300 mm above the ground level as shown in the relevant drawings. The concrete shall be a mixture of cement, granite chips of 20/30 mm mesh and sand in the ratio of 1:2:4. The top of the foundation shall be tapered to allow water to run away from the pole.

Concrete foundations are not required for poles that are hot dip galvanised. In this case the foundation should be backfilled with excavated soil. The backfill should be progressively compacted as the foundation is filled. Do not simply refill the foundation and compact at the surface.

After the poles have been set and the excavated pit backfilled and compacted, the temporary anchors may be removed

### **2.3.3 Erection of DP Structures for angle locations**

Generally, for angles of deviation more than 10 degrees, double pole structure shall be erected. The pits are to be excavated along the bisection of the angle of deviation.

Before the pole is put into the pit, a stone base of 100 mm thick shall be placed at the bottom of the pit. In lieu of 100 mm PCC base, base plate is being used. After erection of the poles the pits will need to be temporarily backfilled so the poles can be climbed and the horizontal bracing fitted. The structure should then be set for verticality and alignment and the supports held in position with the help of temporary rope guys.

The temporary backfilling should be removed and permanent foundations constructed by backfilling, compacting and, if necessary, concreting each pit as described in Section 2.3.2. Concrete foundations are not required if the poles are hot dipped galvanised.

Stays along the bisection of the angle of deviation as required depending on the conductor size and angle of deviation, are to be provided.

### **2.3.4 Special Foundation in Unstable Soil**

Special care has to be taken where foundation in unstable soil is encountered.

In such locations, mass concrete foundations, extending up to the ground level, are to be adopted to avoid collapse of foundation in the unstable soil. The concrete is to be a mixture of cement, granite chips of 20/30 mesh and sand in the ratio of 1:2:4.

### **2.3.5 Anchoring and providing guys for supports**

One or more guys will have to be provided for all supports where there is an unbalanced strain action on the support, which may result in tilting/uprooting or breaking of the

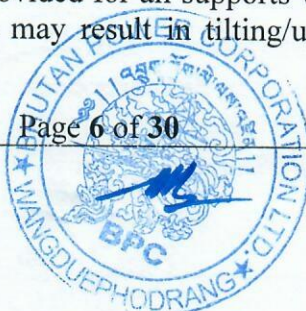



## Technical Specifications

---

support. To avoid such situation arising, guys are provided to take care of the unbalanced forces. Normally, these guys are provided to the supports at the following places: (i) Angle locations (ii) Dead end locations (iii) Tee-Off points (iv) Termination Points (v) Unstable locations and (vi) Steep gradient locations to avoid uplift on the poles.

Guy wires shall be angled at 45° from the vertical for MV lines and 30° from the vertical for low voltage lines.

Single guys shall be provided for single poles with line deviations from 5° to 10° and also for double poles with line deviations not exceeding 30°. Where the angle of deviation exceeds 30°, two guys along the resultant angle of line deviation or one guy in each direction of the line shall be provided. When two or more stays are fixed to the same support, each stay should be attached separately to the pole.

The installation of guy will involve the following works:

- (i) Excavation of pit and fixing guy rod;
- (ii) Backfilling and compacting the guy foundation;
- (iii) Fastening guy wire to the support; and
- (iv) Tightening guy wire and fastening to the anchor.

When installing the guy wire, the turnbuckle shall be mounted at the pole end of the stay and guy wire so fixed that the turn buckle is half way in the working position; thus giving the maximum movement for tightening or loosening. Where the existence of guy wire may be hazardous, it should be protected with a suitable PVC pipe, filled with concrete of about 2-metre length above the ground level, duly painted with white and black stripes. No guy insulator shall be located less than 3 metres from the ground.

### 2.3.6 Fixing of cross arms and insulators

After the erection of supports and providing guys, the next step would be to mount the cross arms on the support. The practice of fixing the cross arm before the pole is erected is followed sometimes but only after the pole painting. In case, the cross arm is mounted after the support is erected, the line-man should climb the support having requisite tools with him. The cross arm is then tied to a hand line and pulled up by the ground man, through a pulley till the cross arm reaches the line-man. The ground man should station himself well to one side so that if any material drops from the top of the pole it may not strike him. All the materials required should be lifted or lowered by means of the hand line. In no case, the materials or the tools should be dropped or thrown from the pole top. Horizontal cross arms and pole top brackets (hamper assemblies) for 33 kV and 11 kV lines as per construction drawings/sketches are standardized. They shall be fitted as shown on the drawings.

The pins for insulators are fixed in the holes provided in the cross arms and the pole top brackets. The insulators are mounted in their places over the pins and tightened. In the case of strain or angle supports, where strain fittings are provided for this purpose, the

straps of the strain fittings are placed over the cross arm before placing the bolt in the hole of the cross arm. The nut of the straps is so tightened that the strap can move freely in horizontal direction, as this is necessary to fix the strain insulator.

### **2.3.7 Laying of AAAC/HV ABC/LV ABC/ACSR Conductor**

During running out, the conductor drum should be securely supported on drum jacks with an axle, so that the conductor is pulled from the top of the drum. The drum jacks should be on a firm foundation and the axle of the drum jack should be leveled horizontally.

Sufficient employees shall be engaged at site to ensure that the conductors are not damaged by contact with the ground or pole hardware during running out. Stringing pulleys shall be used while stringing conductors. Care should be taken to avoid kinking, twisting or abrading the conductor in any manner. The conductor should not be trampled on, run over by vehicles or dragged over the ground. Vehicles should not be used to run out conductors.

Extreme care must be taken to avoid contact with the conductors of any other live line in the vicinity when running out or stringing conductors, and if necessary neighbouring lines should be de-energised during the stringing operation.

Stays shall be installed and kept in position before conductors are strung to avoid over straining of poles. Stringing pulleys shall be used while stringing conductors.

In installing LV aerial bundled cable, the cable must be pulled from the top of the drum and should not be dragged along the ground. A suitable 'drum brake' mechanism shall be used to prevent conductor overrun. Stringing pulleys compatible with bundled conductor shall be installed on every pole. During running out, the cable should be pulled out by hand or by using a nylon-pulling grip designed for bundled cables. Insulated conductor grips designed to prevent damage to the insulation of the conductor shall be used for tensioning. Every care must be taken to avoid damage to the conductor insulation.

### **2.3.8 Mid span jointing of conductors**

Mid-span jointing of conductors shall use compression joints, appropriately sized for the conductor and made with a proprietary compression tool using appropriate sized dies.

### **2.3.9 Sagging and Tensioning of conductors**

After completion of conductor stringing and making any mid-span joints, conductor tensioning operations can commence. The conductors are first attached to the insulator string assembly at the non-tensioning end of the section, using preformed dead-ends. Further, before tensioning commences, temporary guys should be provided as necessary for the anchoring supports at each end of the line section to be tensioned to avoid over-stressing the strain poles due to unbalanced loads.

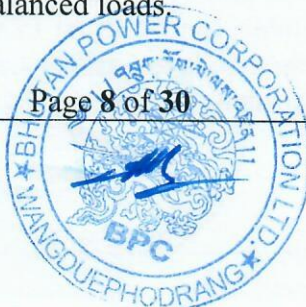

## Technical Specifications

---

The centre conductor should be tensioned first followed by the outer two conductors. At the tensioning end, the conductor being tensioned is pulled manually up to a certain point and then a come-along clamp is fixed to it. The grip to the come-along clamp is attached to a double sheave pulley block or a pull-tight machine and the conductor is gradually tensioned.

The conductor should then be sagged in accordance with the sag-temperature chart for the particular conductor and span. These are given in Section 2.3.10 below. The correct sag should be measured in the middle span of the section.

The stretch of the conductor has to be taken out before sagging in order to avoid the gradual increase in sag, due to the setting down of the individual wires. There are two ways of accomplishing this:

**(i) Pre-stressing**

Using the prestressing method, the conductor is pulled unto a tension considerably above the correct figure, but never exceeding 50% of breaking load for a period of about twenty minutes. As this method requires more time and involves the use of stronger tackle to secure the higher tension, it is not commonly used.

**(ii) Overtensioning**

The overtensioning method consists of pulling up the conductor to a tension of 5%-8% above the theoretical tension for the prevailing temperature and fixing the conductor at that tension with correspondingly reduced sag. Over time, the conductor will settle down to the correct sag and tension.

Conductors can be sagged correctly only when the tension is the same in each span throughout the entire length of the section. Use of snatch blocks during sagging reduces the friction and chances of inequality of tension in various spans.

Measurement of conductor sag can be accomplished by several different methods but most commonly used method is 'sighting'. Targets are placed on the supports below the cross arms. The targets may be light strips of wood, which are clamped to the pole at each end of the sagging span at a distance below the conductor when the conductor is placed in snatch blocks that is equal to the required sag. A lineman sights the sag from the next pole and the tension of the conductor is reduced or increased, until the lowest part of the conductor in the span coincides with the lineman's line of sight.

When sagging is completed, the preformed dead end should be fixed to the tension end. The dead-end and socket thimble can be fitted to the conductor without releasing the tension. A mark is made on the conductor at a distance from the cross arms equal to the length of the complete strain insulator to indicate where the dead-end should be installed.

## Technical Specifications

---

After the dead-end has been installed and the insulator string attached to the top hamper or cross-arm, the conductor is pulled in sufficiently using the come-along clamp, to allow the insulator assembly to be fitted to the socket thimble. After the conductor is attached, the conductor tension may be released gradually. If the tension is released with a jerk, an abnormal stress may be transferred to conductor and support, which may result in the failure of the cross arms, stay or pole.

After the stringing is completed, all poles, cross-arms, insulators, fittings, etc. should be checked to ensure that there have been no deformities, etc.

The conductor is then placed on the pin insulator on each pole ready for tying and to remove the snatch blocks. On straight line poles the conductor should be tied to the top groove of the insulator and on angle poles the conductor should be tied to the side groove. The conductor is then fastened to the insulator using aluminium helities or binding wire.

In fastening the conductor to pin insulators, the following points should be observed:

- (i) The correct size of binding wire, which can be readily handled, and with adequate strength should be used.
- (ii) The length of tie wire should be sufficiently long for making the complete tie including end allowance for gripping each end.
- (iii) A good tie should provide a secure binding between the line conductor and insulator, and should reinforce the conductor on either side of the insulator.
- (iv) The use of cutting pliers for binding the tie wire should be avoided.
- (v) A helities or binding wire that has been used previously should not be reused.
- (vi) Before tying the conductor to the insulator, it shall be ensured that only the portion of helities wrapped with chloroprene pad (where applicable) touches the insulator.
- (vii) At section poles correctly sized parallel groove (PG) clamps must be used to connect the two conductor tails.

### 2.3.10 Conductors Sag and Tension

The following sag-span tables are provided for the guidance of field staff when stringing conductors.

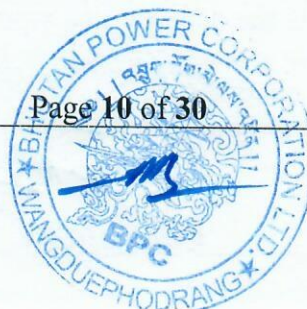

## Technical Specifications

### 2.3.10.1 Low Voltage Aerial Bundled Conductors (ABC)

#### Sag-Span Chart for Low Voltage ABC Conductors

Conductor Size	50mm <sup>2</sup>		95mm <sup>2</sup>	
	Design Tension at 15 <sup>0</sup> C (kN)			
	2.52	5.04	4.79	9.58
Span (m)	Sag (m)			
30	0.15			
40	0.26			
50	0.41			
60	0.59			
70	0.80			
80	1.04			
90	1.32			
100	1.63			
110	1.97			
120	2.35			
130	2.75			

#### Maximum Spans for Aerial Bundled Cable

Pole Length (m)	Maximum Span (m)	
	Across Street	Elsewhere
7.5	50	80 (4 core)
		100 (2 core)

Dead-end (termination) fittings shall be fitted to the conductor after tensioning at each termination point. Intermediate fittings shall then be fitted at major angles and then at smaller angles. After all fittings are in place the sagging should be checked at two places and corrected if necessary.

### 2.3.11 Supports at Different Elevation

Where the supports at each end of a span are at different elevations the following formula can be used for sagging the conductor.

$$d_1 = d(1-h/4d)^2$$

where:

- $d_1$  = vertical distance between the conductor at the lower support and the lowest mid-span point.
- $d$  = sag for a level span equal to the slope distance between the poles. The slope distance is the distance that would be measured by a tape stretched between the two poles. Once this is known the value of  $d$  can be taken from Sag-Span chart above.
- $h$  = difference in height between the conductor at each end of the span.

The above formula can be used to determine the value of  $d_1$ . A sighting board can then be attached to the lower support pole and the conductor sagged be sighting horizontally through it. One way to do this would be to attach a second sighting board to the next pole. Check that the two sighting boards are level using a taut line and spirit level. The sag can then be sighted using the two sighting boards.

### 2.3.12 Good Conductor Stringing Work Practices

#### DO:

- Use proper equipment for handling aluminium conductors at all times.
- Use skids, or similar method for lowering reels or coils from transport to ground.
- Examine the reel before unreeling for presence of nails or any other object, which might damage the conductor.
- Rotate the reel or coil while unwinding the conductor.
- Unwind the conductor in the direction of the arrow on the side of the drum
- Grip all strands when pulling out the conductor.
- Control the unreeling speed with a suitable braking arrangement.
- Use wooden guards of suitable type to protect the conductor when pulling it over barbed wire fences, sharp rock edges or similar obstructions.
- Use long straight, parallel jaw grips with suitable liners when pulling the conductor in order to avoid nicking or kicking of the conductors.
- Use free-running sheaves or blocks with adequate grooves for drawing/paying conductors.
- Measure temperatures accurately with an accurate thermometer.
- Use proper sag charts.
- Mark conductors with crayons or adhesive tape or such other material which will not damage the strand.
- Make all splicing with the proper tools.

#### DO NOT

- Do not handle conductors without proper tools at any stage.
- Do not pull conductors without first ensuring that there are no obstructions on the ground.
- Do not pull out a greater quantity of conductor than is required.
- Do not make jumper connections on dirty or weathered conductor. Instead, clean the conductor with sandpaper. Alternatively apply a chromite or graphite conducting oxide-inhibiting grease to the point of connection and then clean the conductor with a wire brush.
- Do not handle aluminium conductor in a rough fashion but handle it with care it deserves.

At road crossings, a flagman should be in attendance to that traffic is not unduly interrupted. The running of conductor across roads should only be carried out in with the approval of the Authority responsible for the road.



## Technical Specifications

---

Conductor drums should be transported to the tension point without injuring the conductor. If, it is necessary to roll the drum on the ground for a small distance, it should be slowly rolled in the direction of the arrow marked on the drum.

When running out conductor the drum should be so supported that it can be rotated freely. For this purpose, the drum should either be mounted on the cable drum supports or jacks or hung by means of chain pulley of suitable capacity, suspended from a tripod. If it is not possible to raise the conductor drum by any of the above methods, a trench of suitable depth slightly bigger than the conductor drum may be dug, so as to facilitate free rotation of the drum when it is suspended above the trench using a steel shaft. While running out the conductor, care should be taken to ensure that the conductor does not rub against any metallic fitting of the pole or on the uneven or rocky ground. Wooden trusses may be used for this purpose to support the conductor when running out.

Should the length the conductor be less than the length of the section, the conductors should be run out from both ends and joined where they meet with a mid-span full tension joint.

On no account, should any part of the conductor shall be left overnight at a height of less than 5 metres above the ground. The work should be so arranged that before the end of the day, the conductor is raised to a minimum height of 5 metres above the ground by rough sagging.

### **2.3.13 Earthing of Distribution Lines**

All MV line steel poles should be separately earthed. The earth pin is a 2.5 m galvanised steel rod, which must be driven into undisturbed ground clear of the pit excavation. It is not acceptable to insert the earth rod in the pit excavation as the backfill used often does not provide a good earth connection.

The earth pin is connected to the pole using No 8 SWG galvanised steel wire/GI Strip as shown in the drawings. Lugs and bolts must be used for both the connection to the pole and to the earth pin. Wire wrapped connections are not acceptable as a good electrical connection cannot be assured.

The earth resistance of the pole and earth pin connected together should be as low as possible and ideally should not exceed 10 ohms. Additional earth pins, spaced at least 1 metre apart, should be used in difficult locations, to reduce the resistance.

The earthing stake for pole earths is also used for earthing LV distribution pillars.

The earth resistance of the earth stake and pole connected together should be measured and recorded every tenth pole. The earth resistance of a greater percentage of poles should be measured if earth resistances are high or if there is high soil variability.

### **2.3.14 Final Completion and Commissioning**

Before commissioning a line into service, the line shall be visually checked over its full length to ensure that all structures are correctly installed, all pole earths are installed and connected, all conductors are correctly bound and terminated on all structures and all tools and other equipment have been removed.

The line shall be energised with all distribution substations isolated and unloaded on the low voltage side. Where the line is directly connected to a zone substation supply bus, rather than to an upstream line, the protective relay settings should be reduced. Once the line has been successfully energised, the correct protection relay settings should be applied and the distribution substations connected to the load one at a time.

In energising distribution transformers for the first time, the MV drop out fuse should first be closed to liven the transformer on no load. The transformer can then be loaded by closing the incoming MCCB in the LV feeder cubicle.

## **3. Underground Cable Installation**

### **3.1 General Scope**

This specification covers the requirements of Cabling System installation work. The installation, testing and commissioning of the complete cabling system shall be carried out as stipulated in this specification. This shall cover the requirements of supply of cabling accessories such as lugs, glands, jointing and terminating boxes/kits, junction/ marshalling boxes, cable trays, conduits and pipes to complete the work in all respects. These notes in general cover cables upto and including 33 kV rating.

### **3.2 Codes and Standards**

**3.2.1** The cabling system installation work shall comply the latest applicable standards, regulations and safety codes of the locality where the installation is carried out. Nothing in this specification shall be construed to relieve the Contractor of this responsibility.

**3.2.2** The installation work shall conform to the latest applicable codes of practices, Electricity rules, Fire Insurance Regulations and standards.

### **3.3 Installation Work Scope**

#### **3.3.1 Scope**

a) The installation work shall include unloading, storing, laying, fixing, jointing/ termination, testing, commissioning and any other work items necessary completing the job.





## Technical Specifications

---

- b) The Contractor shall furnish all supervision, labour, tools, welding equipment, tackles and testing equipment as required for installation work. All incidental hardware and miscellaneous items such as saddles, spacers, nuts/bolts/washers, anchor fasteners, cable route and joint markers and protective covers for buried cables, cable identification tags and ferrules, nylon cord/G.I. wire, earthing as required for the cabling installation shall be deemed to be included by the Contractor as part of installation work.
- c) Civil works for constructions of built-up cable trenches/tunnels/duct banks, cable carrier supports on main pipe rack structure, provision of embedded conduits/pipes in RCC masonry structures and across roads are included in Contractor's scope.
- d) The Manufacturer's drawings, cable schedules, instructions and recommendations shall be correctly followed by the Contractor in handling, laying, testing and commissioning of the cabling system. In case of any doubt/misunderstanding as to correct interpretation of drawings/instructions, necessary clarifications shall be obtained by the Contractor from the Employer.
- e) Any changes in routes of cables which are required to be made to suit site conditions shall be carried out by the Contractor in consultation with the Engineer and after his approval. All such changes shall be marked by the Contractor on relevant drawings/in cable and conduit schedule.
- f) All thefts and damage of cables or equipment to which cables are to be connected, till the installations is handed over to the Employer, shall be made good by the Contractor.
- g) It will be responsibility of the Contractor to clean the trenches/tunnels, remove cable drums, surplus/waste materials and all other similar items after the installation work is completed.

### **3.3.2 Cable Laying**

- a) The Contractor shall install, test and commission all power and control cables. The quantities, sizes and types of cables shall be indicated in Bill of Quantities.
- b) The cable shall be laid in built-up trenches, directly buried in ground, cable ducts, on cable trays vertical raceways, clamped on structures/walls/ceiling, pulled through pipes and conduits etc., as per the relevant cable installation practice notes and drawings.
- c) The Scope of cable laying shall include laying, pulling cable as above, proper dressing of cables on cable trays, racks, vertical raceways and supply and

installations of cable fixing saddles, spacers and nylon cord for tying as required. The installation of trefoil/wooden clamps for clamping the cables shall be included in the installation cost of relevant cables including excavation, backfilling, etc. However, during layout of cable do not drag the cable on surface of ground, roads, etc. including pulling with excessive force especially with help of vehicle.

- d) Where cables are to be installed at temperatures below 3 ° C, they shall be heated to about 10 ° C for not less than 24 hours (in a heated building or in a tent with hot air heater) to facilitate laying (otherwise the bending would damage the insulation and protective coverings of cables). The cable laying must be carried out swiftly so as not to allow the cable to cool down too much.
- e) Control cables and small power cables in trenches and tunnels shall be run in ladder type cable trays (maximum tray width 600 mm) supported on trench/tunnel carrier arms. Control and power cables shall be clamped separately. It will be the responsibility of the Contractor to check the neatness of such cable runs and to see that horizontal/vertical runs of cables are parallel to fixed axes in respective plans. The cables shall be laid to tray rungs by means of 3mm dia. nylon cord at an interval of 5000 mm and also at bends.
- f) For good sealing arrangement at entry points, suitable pipe sleeves, adequate in number and of adequate sizes shall be provided in building walls/slabs for passage of cables into a building from cable trays/racks/cable trenches located outside the buildings.

### 3.3.3 Cabling

- a) Standard cable grips and reels shall be utilised for cable pulling. Care shall be taken to avoid damage to the cable and seal, which shall be made up and maintained during cable installation. If unduly difficult pulling occurs, the Contractor shall check pull required and suspend further pulling until further procedure has been approved by the Engineer. Maximum pull tension shall not exceed recommended value for the cable measured by the tension dynamometer. In general, any lubricant that does not injure the overall covering and does not set up undesirable conditions of electrostatic stress or electrostatic charge may be used in pulling insulated cables in conduits and ducts. In particular soap shall not be used as lubricant. For cables over 2,000 volts and having non-metallic jackets without adequate static shielding, the lubricant should not include graphic or hygroscopic greases that will leave a conducting film on the surface of the cable. It is not considered likely that all cable to be pulled from any pulling location can be pulled consecutively without moving and later backtracking, and it may be required that cables reels and equipment be moved from pulling locations when no actual pulling is in progress to allow performance of collateral work, and when so requested by the Engineer, such reels and equipment shall be removed. When pulling cable from any pulling location, reels shall be laid out from locations, which will permit performance of collateral work without obstruction.



## Technical Specifications

- b) After pulling cable, the Contractor shall record cable identification and date pulled, neatly with water-proof ink on linen tags at all cable ends. This is in addition to the cable identification tags to be tied by GI wire at each end of the cable.
- c) Cable take-off from drums shall be so planned as to avoid using joints and splices in the run of the cable. Cable splices will be made only after obtaining permission of the Engineer. Splices where permitted, shall be made in a neat workmanlike and approved manner by man specialised in this class of work, particular attention being paid to higher voltage splices and splices involving armour or lead sheath constructions. Splices shall be made by the Contractor for each type of wire or cable in accordance with the instructions issued by the cable Manufacturer and the Engineer. Before splicing, insulated cables shall have conductor insulated stepped and bound or pencilled for recommended distance back from splices to provide along leakage path. After splicing, insulation equal to that of the spliced conductors shall be applied a teach splice. In baring conductors for splices, care shall be taken to avoid nicking of strands.
- d) Cables shall be protected at all times from mechanical injury and from absorption of moisture at unprotected ends. Damaged cables shall be replaced at the Contractor's expense.
- e) Sharp bending and kinking of cables shall be avoided. The bending radii for various types of cables shall not be less than those specified below, unless specified in cable installation notes.

DESCRIPTION	SINGLE CORE	MULTICORED ARMoured	MULTICORED UNARMoured
PVC insulated cable upto 11 kV	20 D	12 D	15 D

Where D = Overall diameter of cable.

(For XLPE insulated cables, recommendations of manufacturers to be followed).

If shorter radius appears necessary, no bend shall be made until clearance and instructions are obtained from the Engineer.

The above values may be reduced to 70% when making only one bend such as in case of installing an end termination.

- f) When power cables are laid in the proximity of communication cables, minimum separation between power and communication cables shall be not less than 460 mm for single-core cables and 300 mm for multi-core cables. Power and communication cable shall, as far as possible, cross at right angles to each other.

- g) The end portions of directly buried cables shall be protected as indicated in the relevant enclosed typical drawing by bringing out the cables from earth at the entry/exit points in conduits/pipes.
- h) Unarmoured cables shall be protected in conduits up to 2.5 meters from floor level.
- i) The Contractor shall make connections to small electrically operated devices on equipment installed as accessories to, or assemble with other equipment and requiring two-wire or three-wire connections. Connections to recording instruments float switches, limit switches pressure switches, thermocouples, thermostats and other miscellaneous equipment shall be done as per the Manufacturer's drawings and schedules.
- j) The Contractor shall be responsible for correct phasing of the motor power connections and shall interchange connections at the motor terminal box, if necessary, after each motor is test run.

#### **3.3.4 Cable Termination**

- a) All cables that will be laid by the Contractor shall be connected at both ends to switchgear, panels, equipment, local push buttons, instruments or junction/marshalling boxes terminals as the case may be.
- b) The scope of termination at each and shall include dressing and connection of all the cores of the cables. The following shall be included in this scope of work:
  - (i) Making the requisite holes in the bottom/gland plate of the switchgear for cable boxes/glands, fixing the cable boxes/glands, terminating the cables in the cable boxes/glands, earthing the cable armour, crimping the cable lugs on each core neatly, clamping the cables inside switchgear/panels cable alleys, wiring troughs and connecting to correct terminals as per the Manufacturer's wiring diagrams and cable schedules. The cable and core identifying lugs and ferrules respectively shall be supplied and installed by the Contractor as part of cable termination work.
- c) All cable terminations shall be solderless crimping type. Proper crimping tools shall be used by the Contractor. The crimping tools used shall be subject to the Engineer's approval.
- d) Spare cores of control cables shall be connected to spare terminal blocks, where available, with appropriate ferrules. If there are no spare terminal blocks, the spare core shall be bunched together and shall be neatly kept inside the panel.
- e) At cable terminal points where the conductor and cable installation will be terminated, terminations shall be made in a neat, workmanlike and approved manner



## Technical Specifications

---

by men specialised in this class of work. Terminations shall be made by the Contractor for each type of wire or cable in accordance with instructions issued by cables Manufacturer and the Engineer. The Contractor shall have on hand at the job site the Manufacturer's drawings on high voltage cable terminations. Terminations shall be made using compression type lugs. Main runs of power and control cables will consist of PVC/XLPE insulated armoured or unarmoured cables. Terminations of such cables will generally occur in terminal boxes where splices may be required, using a special compressing or clamp type termination, beyond which PVC insulated conductor, will continue to the terminals of the control device. Terminal boxes in which splices occur will require filling with compound after completion of splices.

- f) Where terminal boxes have wiping sleeves, the lead sheath of cable shall be belled in an approved manner to fit, and a standard wiped joint made, using steaming flux and lead heated to proper temperature. Where conduits continues with cable to terminal box and mechanical clamping of lead sheath of cable is required, sheath shall be belle, trimmed and clamped in a good and approved manner. Before any cable terminal connections are made, conductors shall be rung out and identifying tags shall be installed as required by the Engineer. Connections shall be made according to wiring diagrams. Polarity of phasing shall be checked before connections are made, and correction of polarity, phasing or rotation shall be made by the Contractor without additional cost.
- g) Control cable terminations shall be made in accordance with wiring diagrams/cable interconnection diagram and cable schedules. It is the intend that the Contractor shall terminate the cables which he installs. Additional work of testing and reconnection where leads have been brought by the Contractor to terminal boards and connected, but where on further testing, reversal or other rearrangement of load turns out to be necessary, additional work of testing and reconnecting shall be performed by the Contractor at no extra cost to the Employer.
- h) When control cable cores are to be fanned out and cabled together with core, the Contractor shall make connections to terminal blocks, and test equipment for proper operation before cables are corded together. If there is any doubt as to proper connection, the Contractor shall make temporary connection with sufficient length of cable so that cable can be switched to another terminal without splicing cable. Splices will not be accepted, and any cable cut out short shall be replaced and installed, at the Contractor's expense. After correct connections are established through operating equipment, cables shall be cut to correct lengths connected to terminals in the specified manner and corded together where necessary to hold cables in place in a workman-like manner.

### 3.3.5 Associated Work for Direct Burial of Cables, Conduits and Pipes

- a) The Contractor's scope of work for the cable trenches required for directly buried cables shall include excavation, preparation of riddled soil bedding, supply and installation of protective covers i.e. tiles for HT cable and bricks for LT cables,

back-filling, ramming and installation of route markers and joint markers. The details of construction work and provision of protective covers and markers shall be as indicated in the enclosed drawings of installation practice for directly buried cables. The sizes of these trenches shall be as indicated in the Drawing.

- b) The Contractor's scope of construction work for directly buried pipes/conduits shall be excavation and back filling as per varying depths/widths required in drawings.
- c) In each cable run greater than 50 metre, some extra cable length shall be kept at a suitable point to enable a straight through joint to be made should the cable develop fault at a later date.
- d) Where cables cross roads, water or sewage pipes, the cable shall be laid in hume or steel pipes. For road crossings the pipe for the cable shall be buried at not less than 600 mm unless otherwise noted in the drawings. Hume pipes shall be preferred to that of steel pipes from the point of view of corrosion.

### 3.3.6 Cable Joints

- a) Cables to each circuit shall be laid in one continuous length. Cable jointing and splicing shall be done after obtaining Site Engineer's permission. The work shall be carried out as per the cable and jointing kit Manufacturer's instructions furnished to the Contractor.
- b) The scope of jointing of various sizes and types of power cables indicated in Bill of Quantities shall include all necessary special tools and incidental accessories for testing of the joints and as per specification.
- c) Directly buried cables shall be laid as per the drawings and cable route markers shall be provided. At least one marker shall be provided if the length of the buried cable is less than 15 metres. Buried cables in trefoil formation shall be bound by plastic tapes or 3mm dia. nylon core every 750 mm.
- d) Jointing of cables shall be carried out in accordance with relevant Standard Codes of Practice and the Manufacturer's special instructions. Hardware like clips and clamps and tools required for cable jointing work shall be supplied by the Contractor. Cables shall be firmly clamped on either sides of a straight through joint at not more than 300 mm away from the joints. Identification tags shall be provided at each joint and at all cable terminations. Single core cable joint shall be marked so that phase identity at each can be determined easily. The joints shall be located at the most suitable places. There shall be sufficient overlap of cables to allow for the removal of cable ends which may have been damaged.
- e) Joint pits shall be of sufficient dimensions to allow the jointers to work with as much freedom as possible. When two or more cables are laid together, joints shall be arranged to be staggered by about three metres.

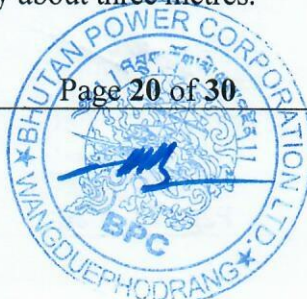

## Technical Specifications

---

- f) Cable seal shall be examined to ascertain if they are intact and also that cable ends are not damaged. If the seals are found to be broken or lead sheath punctured, the cable ends shall not be jointed until after due examination and testing by the Engineer. Before joining is commenced, insulation resistance of both sections of cables to be jointed shall be checked by megger and insulation values recorded.

### **3.3.7 Junction/ Marshalling Boxes/ Button Station Installation**

- a) The Contractor shall install the junction/marshalling boxes wherever necessary.
- b) The scope of installation of junction/marshalling boxes and push-button stations shall be mounted on wall, columns, and structures, including necessary bolts, nuts, screws and welding work as necessary.
- c) Cable entry to motors, push button stations and other electrical devices shall be from the bottom as far as possible or from the sides. Top entry shall be avoided particularly for outdoor equipment.
- d) Identification tags made from aluminium sheet shall be attached to each end of each cable by means of GI binding wire as shown in drawing. Tags shall be additionally put at an interval of 30 meters on long runs of cables and in pull boxes.
- e) Wooden cleats when required for vertically supporting on or more single core cables per phase, such as on vertical framework near transformer cable boxes, shall be made out of well-seasoned wood given two coats of fire retarding paint of approved quality.

### **3.4 Earthing of Cables**

- a) Metallic sheaths, screens and armour of all multicore cables shall be earthed at both equipment and switchgear end.
- b) Sheath and armour of single core power cables shall be earthed at switchgear end only. If specifically indicated in drawings, for long lengths of cables multiple earthing may have to be adopted to safeguard against the presence of standing voltage under normal as well as fault conditions.
- c) Earthing of CT and PT neutral lead shall be at one end only.
- d) Metal sheath and armour of the cable shall be bonded to the earthing system of the station. Bond shall be of at least 70 sq.mm copper conductor unless otherwise specified.

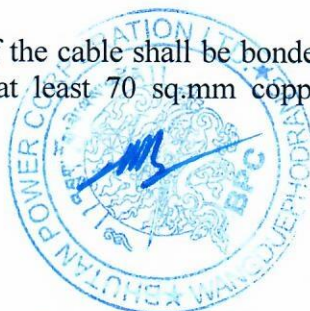

### **3.5 Testing of Cables**

- a) All new cables shall be megger tested before jointing. After jointing is completed all L.V. cables shall be megger-tested and H.V. cables (3.3 kV and above) pressure tested before commissioning. The test voltage for pressure testing shall be as per the relevant cable standards. 1100/650 Volt grade cables shall be tested by 1000 volt Megger.
- b) The Contractor shall furnish all testing kit and instruments required for field testing.
- c) All cables of 1.1 kV grade 400 sq.mm and above and all HV cables shall be subjected to DC or AC high voltage test after jointing and terminating but before commissioning as per the relevant standards. Testing with DC voltages should be preferred as test equipment required is compact, easily portable and requires low power. The cable cores must be discharged on completion of DC high voltage test and cable shall be kept earthed until it is put into service.
- d) DC test voltage for old cables is 1.5 times rated voltage or less depending upon the age of cables, repair work or nature of jointing work carried out.
- e) In each test, the metallic sheath/screen/armour should be connected to earth.
- f) Continuity of all the cores, correctness of all connections as per wiring diagrams, correctness of polarity and phasing of power cables and proper earth connection of cable gland, cable boxes, armour and metallic sheath shall be checked.

## **4. Installation of Distribution Transformer Substations**

### **4.1 Selection of Site**

The location of distribution transformer substations should ideally be:

- as close as possible to the centre of the load, in order to reduce the voltage drop in the low voltage circuits;
- in a location that is clear of obstructions and that provides satisfactory access for the incoming medium voltage overhead distribution line;
- readily accessible for transportation of the distribution transformer to site;
- above a road rather than below it where this is practical; and
- in a location likely to provide a low resistance to earth.

### **4.2 Installation of PAD Mounted Distribution Transformers**

This method is suitable for transformer capacity of 250 kVA and above. The floor level must be higher than the surroundings to prevent flooding. The foundation should be preferably of concrete. The type of foundation permits drainage of the transformer.





## Technical Specifications

---

Gravel should be spread all round for the purpose of effectively controlling the growth of grass and weeds and to prevent the spreading of dust. A soaking pit shall be constructed for the absorption of the leaking oil. If a number of transformers are located close together, fire proof barrier walls should be provided to limit the damage arising from a mishap to any transformer. The enclosures of floor-mounted transformers should be designed to permit free circulation of air on all sides. If possible, the outdoor transformers should be protected against direct sun's rays. This will lower the maintenance charges on painting and also prolong their life. The roller of the transformers after being placed in its final position should be firmly locked to prevent any movement during storms.

### 4.3 Fencing Arrangement

Pad mounted substation should be enclosed around preferably with chain link fencing or netting of one strand of barbed wire at the top. This is done to keep away animals and unauthorized person entering into the substation yard. Suitable gates should be provided for transporting the equipment in the yard. Good illumination is necessary in a substation to ensure normal operation and maintenance activities and safety of working personnel. Generally, 10x10 meter fencing is provided as substation fencing for pad mounted transformers. For bulk transformers, where HT meter equipment is to be provided in the substation yard, 10x15 meter yard fencing is to be provided. These days such arrangements were constantly being replaced by compact substations/unitized substation. Details of substation fencing is given on drawing no. BPC-DDCS-2014-58.

### 4.4 Substation Earthing

Particular care should be given to the construction of the earthing system as proper earthing of distribution transformer substations is necessary to ensure safe operation of the supply system. The earth pits should be located as shown in drawing and the earth connections to the substation structure are shown in drawing BPC-DDCS-2014-60.

BPC's standard earthing conductor for transformer substation is 25xg mm galvanized iron flat. Three electrodes forming an equilateral triangle with minimum distance of 6500mm, so that adequate earth buffer is available. Each electrode shall be GI pipe of 4 mm thick, 40mm outer dia and 2500mm long and buried vertically so as to leave about 4 inch pipe length above ground level to fix a 250x250mm G.I plate. The three earth electrodes should be connected together by an equi potential earthing ring embedded at least 100 mm below ground level. These are connected as follows:

- 1) One earth electrode is connected to earth lighting arrestor and the transformer tank. It is important that the earthing conductor is kept as short as possible.
- 2) The second earth electrode is connected to the transformer LV neutral bushing, the transformer tank and the crossarms supporting the drop-out fuses.
- 3) The third earth electrode is also connected to the transformer tank and LV neutral and also to the earth in the low voltage distribution cabinet.

There shall be minimum joints preferably no joints enroute to earth electrodes. Where joints are unavoidable, they shall be brazed, riveted or welded (and painted with red lead and aluminium paints one after the other and finely coated with bitumen).

#### **4.5 Transportation and Handling of Transformers**

Distribution transformers should be stored in such a way that 'first in first out' becomes a normal procedure. Care must be taken to place the transformers in store in such a fashion that no damage occurs to tank, bushings, etc. due to movement of personnel and materials.

Transformers should be loaded and unloaded with care. Prior to loading a transformer for dispatch to site, the transformer condition (bushings, fittings, tank, oil level, etc.) should be checked. If any damage is noticed, the in-charge should be notified immediately, and transformer should be loaded only after the written approval of the person in charge. The BDV value of the transformer oil should be checked and transformer should be loaded only after written approval of the In-Charge.

Every transformer dispatched to site should be entered individually in store register. This register should have the following:

- (i) Serial Number
- (ii) Date of receipt
- (iii) Transformer capacity (kVA)
- (iv) Manufacturer's name
- (v) Date of Despatch to site
- (vi) Name of site
- (vii) Technical test reports

Transformers should be lifted using the lifting lugs provided on the transformer tank and the lifting arrangement should not cause unbalance of the transformer. Before lifting the complete transformer, it should be ensured that all cover bolts are tightened. The slings, lifting tackle, etc. to be used in hoisting of transformers should have adequate strength to handle the weight.

During transport of transformers, they should be rigidly secured to the transport vehicle and packing materials put on either side of the base of the transformer to prevent skidding. A responsible official shall supervise the loading. Rollers, if provided, should be removed.

Care should be taken in transporting transformers to site to prevent the transformers moving when going up and down hills and around corners.

Transformer should be brought just adjacent to the mounting structure for installation. Lifting tackle should be used for hoisting transformer on structure.



## Technical Specifications

In case, it is not possible to bring the vehicle carrying transformer near the mounting structure, it should be unloaded at a nearest safe place and carried to the mounting structure manually with great care and under proper supervision or shifted on platforms fitted with rollers.

While installing transformers on the Transformer Platform, safety precautions by way of fixing additional clamps and bolts should be taken.

Readymade slings to suit the capacity of transformer should be available.

### 4.6 Substation Structure and Earthing

The distribution substation structure and earthing of the equipment and structure shall conform to the relevant construction drawings. The maximum permissible earth resistance is 5 ohms.

### 4.7 Protection of distribution transformers

Dropout fuses are provided on H.V side of the transformer for isolating and protection.

MCBs and fuses are provided on the LT side of the transformer for isolating and for protection against feeder faults.

Acceptable Transformer Medium Voltage Fuse Link Ratings

MV Rating (kV)	Phases	Capacity(kVA)	Rated Current(A)	Fuse Link(A)
33	3	63	1.1	2 to 4
33	3	125	2.2	4 to 7
33	3	250	4.4	9 to 16
33	3	500	8.7	16 to 32
33	1	10	0.3	1 to 2
33	1	16	0.5	1 to 2
33	1	25	0.8	2 to 3
11	3	16	0.8	2 to 3
11	3	25	1.3	2 to 4
11	3	63	3.3	7 to 9
11	3	125	6.6	16 to 25
11	3	250	13.1	32 to 40
11	3	500	26.2	50 to 100
11	3	1250	65.6	150 to 300
11	1	10	0.9	2 to 3
11	1	16	1.5	3 to 7

### Technical Specifications

6.6	3	20	1.7	3 to 7
6.6	3	30	2.6	4 to 9
6.6	3	50	4.4	9 to 16
6.6	3	75	6.6	16 to 25
6.6	3	125	10.9	25 to 40
6.6	1	10	1.5	3 to 7
6.6	1	16	2.4	4 to 7
6.6	1	25	3.8	9 to 16

LV cable specification for connection from Transformer LV side to DP

Phases	Transformer (kVA)	Rating	Maximum Current (A)	LV	LV Size(mm <sup>2</sup> )	Cable
3	10		14			4Cx35
3	16		23			4Cx35
3	25		36			4Cx35
3	63		91			4Cx70
3	125		180			4Cx150
3	250		361			4cx300
3	500		722			2Rx4cx300
3	1250		1804			2Rx4cx630
1	10		43			2Cx35
1	16		70			2Cx35
1	25		109			2Cx35

#### 4.8 Installation of Distribution/Mini Pillars

Distribution pillars are used to connect consumer's service cables to the distribution cables in urban underground systems. They shall have a degree of protection of IP 55 or better with bottom cable entry to avoid water ingress. The minimum panel thickness shall be 2.5 mm, and there shall be a removable gland plate of minimum 3 mm thickness. There shall be a lockable hinged door with a minimum thickness of 2 mm. Separate aluminium phase and neutral busbars shall be provided.

Outgoing cables shall be protected by single pole miniature circuit breakers (MCBs). MCBs shall be of the hand operated, trip free, air break, thermal and magnetic tripping type and comply with IEC 60898 and IEC 60947-2.

MCBs do not have adjustable overload settings. The size of MCB to be used to protect the standard underground service cables is shown in Table.

Maximum MCB ratings for Underground Service Cable



## Technical Specifications

Cable Size(mm <sup>2</sup> )	No. of Cores	Maximum MCB rating(A) <sup>1</sup>
35	4	100
16	2	63
6	2	32

### 4.9 Connection of Supply to Consumer's Premises

Supply to consumer premises through a 2 or 4 core overhead cable in situations where consumers are fed from the overhead system and a 2 or 4 core underground cable when fed from an urban underground system.

The connection arrangement for a single phase consumer shall be as per the relevant drawings. The residual current circuit breaker (RCCB) shown in the drawing is optional but the remainder of the circuit is mandatory. All components except the energy meter shall be provided by the consumer. The energy meter will be provided by BPC.

A new connection should not be livened unless;

- The consumer has installed an MCB as a point of isolation;
- The consumer has installed a stake earth, which is connected to a main earth terminal on the consumer's distribution board;
- Each and every power point is properly earthed;
- There is a link between the earth terminal and the incoming neutral. As shown in the drawing, the configuration of this connection will depend on whether or not the customer chooses to connect an RCCB.

### 4.10 Consumer Metering

The choice of meter to install in consumer installation will depend on the expected load. Three types of meter are available:

- Direct connected, where the meter is directly connected to the incoming low voltage supply;
- CT metering, where the meter is indirectly connected to the low voltage supply through a current transformer; and
- High voltage metering, where the consumer is supplied at high voltage and the meter is indirectly connected to the high voltage supply through a high voltage metering unit.

### 4.11 Direct Connected Metering

Direct connected metering should be used when the consumer load is not expected to exceed 60 A. Standard direct connected meters used by BPC are given in table below:

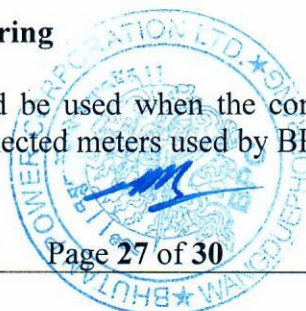

BPC Standard Direct Connected Meters.

Phase	Meter Type	Capacity (A)	Class
1	Electromechanical	2.5/10	2
1	Electromechanical	5/20	2
1	Electromechanical	10/60	2
3	Electromechanical	5/30	2
3	Electromechanical	20/80	2

The class of meter indicates its accuracy and the meter capacity indicate the current range over which the accuracy can be assured. Hence a class 2 10/60 A meter can be expected to have a metering accuracy of 2 % over a current range of between 10 and 60 amps.

**4.12 CT Metering**

Where the consumer is supplied at low voltage and the expected maximum three phase load is greater than 60 A, current transformer (CT) metering should be used. All current transformers have a 5 A output and feed into a standard 5 A, class 1 electromechanical meter. The load shown on the meter needs to be multiplied by the CT ratio to give the actual consumption.

CTs currently used by BPC have a ratio of 100/5, 200/5, 300/5, 400/5, and 500/5 and have an accuracy of class 1 and a burden of 15 VA.

Care must be taken to ensure the correct multiplier is used when measuring consumption using CT metering.

**4.13 High Voltage Metering**

Consumers supplied at high voltage must provide a high voltage metering unit acceptable to BPC. The high voltage metering unit shall incorporate potential and current transformers. The current transformer shall be class 0.5, have a maximum burden of 15 VA and have either a 1 A or 5 A output. The voltage transformer shall be class 0.5, have a maximum burden of 15 VA and have a 110 V output.

BPC will connect its own class 0.5 trivector electronic meters meeting the requirements of IEC 60687 to the consumer's high voltage metering unit. The meter shall incorporate a data logging facility and be capable of recording a range of different power system parameters at the point of connection.

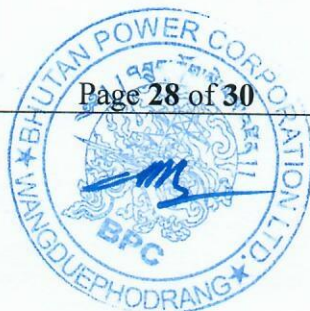

# Section VIII

## PRICE SCHEDULE



**Price Schedule**

**Package A: Right of Way (RoW) clearing of Distribution Lines and casting of poles.**

**Location: Wangdue Dzongkhag**

Sl.#	Description	Unit	Quantity	Rate (Nu.)	Total Amount (Nu.)
1	<b>Clearing of Right of Ways (RoW) along the MV line for 33kV &amp; 11kV, cutting of trees &amp; trunks, debranching, including thorough cleaning of bushes, creepers along the identified MV line route.</b>				
1.1	33kV line (RoW width of 12 mtrs)	Km	65		
1.2	11kV line (RoW width of 9 mtrs)	Km	45		
2	<b>Providing and laying in position plain cement concrete including the cost of centering and shuttering - Casting of pole base as per drawing. (CM ratio 1:3:6)</b>				
2.1	Steel tubular pole (HT and LT poles)	Nos.	500		
	<b>Total offered bid price (Nu)</b>				
	<b>In words (Ngultrum)</b>				

Note:

The quantities mentioned here are indicative and are estimated values. These are subject to change at the time of execution. Payments shall be made based on the actual volume of works done at the rate or price set in the price schedule of the Contract.





**Price Schedule**

**Package B: Construction works associated with Extension of LT lines**

**Location: Wangdue Dzongkhag**

Sl.#	Description	Unit	Quantity	Rate (Nu.)	Total Amount (Nu.)
1	Route survey, transportation of materials (both head loading and vehicular from stores to sites), erection of poles & stay sets, stringing of LV ABC, fittings & accessories, testing, commissioning and other associated works including jungle clearance if required.				
1.1	Low voltage lines (ABC) with Steel Tubular Poles				
a	4 core, 50 sq. mm	Km	4		
b	2 core 50 sq.mm	Km	4		
	<b>Total offered bid price (Nu)</b>				
	<b>In words (Ngultrum)</b>				

Note:

The quantities mentioned here are indicative and are estimated values. These are subject to change at the time of execution. Payments shall be made based on the actual volume of works done at the rate or price set in the price schedule of the Contract.



# Section IX

# BID FORM



# Standard Form: Form of bid

*Notes on Form of Bid:*

*The Bidder shall fill in and submit this bid form with the Bid. If Bidders do not fill in the Contract Price and does not sign this Bid form, the bids will be rejected.*

\_\_\_\_\_ [date]

To \_\_\_\_\_

Address \_\_\_\_\_

\_\_\_\_\_

\_\_\_\_\_

We offer to execute the contract for construction of “\_\_\_\_\_” in accordance with the Conditions of Contract accompanying this Bid for the Contract Price of \_\_\_\_\_ [amount in figures] ( \_\_\_\_\_ ) [amount in words] \_\_\_\_\_ [name of currency].

The contract shall be paid in Ngultrums (Nu.)

This Bid and your written acceptance of it shall constitute a binding Contract between us. We understand that you are not bound to accept the lowest or any Bid you receive.

We hereby confirm that this Bid complies with the Bid validity and Bid Security required by the bidding documents and specified in the Bidding Data.

Authorized Signature: \_\_\_\_\_

**(Affix Legal Stamp)**

Name and Title of Signatory: \_\_\_\_\_

Name of Bidder: \_\_\_\_\_

Address: \_\_\_\_\_



# Section X

## SAMPLE FORM



**TO WHOM MAY IT CONCERN**

This is to certify that Mr/Ms .....bearing CID no  
..... representative of M/s ..... Construction  
has visited site along with our BPC official at ..... work site at  
.....gewog under .....Dzongkhag from on ...../...../2021.

BPC Officials

Signature: \_\_\_\_\_

Name: \_\_\_\_\_

Designation: \_\_\_\_\_



# Section XI

# DRAWINGS



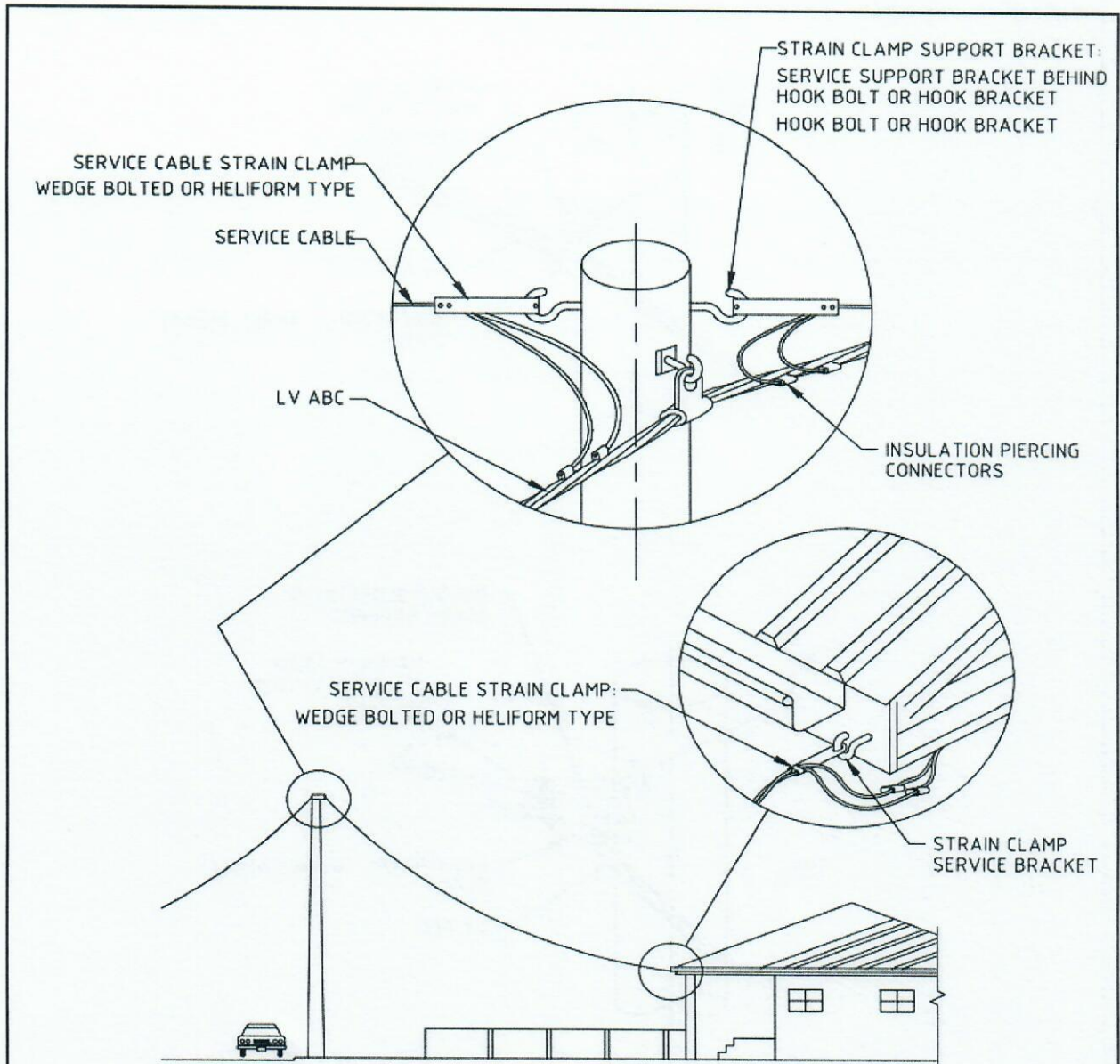

**NOTES**

1. DIMENSIONS AS SHOWN ARE IN mm.
2. DRAWING IS NOT TO SCALE.

	<b>BHUTAN POWER CORPORATION LIMITED</b>		<b>ENGINEERING DESIGN &amp; CONTRACTS DEPARTMENT</b>	
			<b>DISTRIBUTION DESIGN AND CONSTRUCTION STANDARDS</b>	
		<b>LV ABC TYPICAL SERVICE LAYOUT ARRANGEMENT</b>		
DESIGNATION	NAME	DATE	DRAWING NO. BPC - DDCS - 2015-14	
DRAFTSMAN				
DESIGNER				
DESIGN CHECK				
PROJECT MANAGER				
PROJECT DIRECTOR			<b>REVISION</b> 2015	



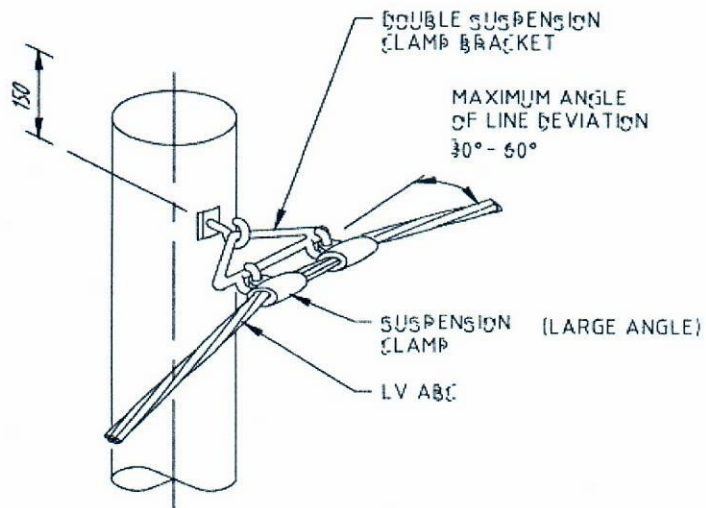
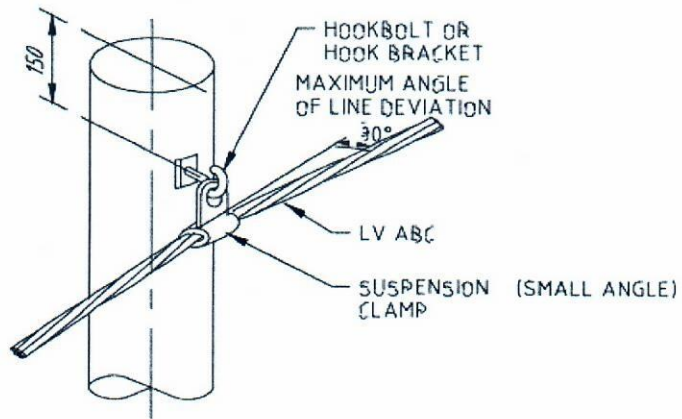

**NOTES**

1. DIMENSIONS AS SHOWN ARE IN mm.
2. DRAWING IS NOT TO SCALE.



**BHUTAN POWER CORPORATION LIMITED**

**ENGINEERING DESIGN & CONTRACTS DEPARTMENT**

**DISTRIBUTION DESIGN & CONSTRUCTION STANDARD**

**LV ABC  
INTERMEDIATE & ANGLE POLES DETAILS**

DESIGNATION	NAME	DATE
DRAFTSMAN		
DESIGNER		
DESIGN CHECK		
PROJECT MANAGER		
PROJECT DIRECTOR		

DRAWING NO. BPC-DDCS-2015-15

REVISION  
2015

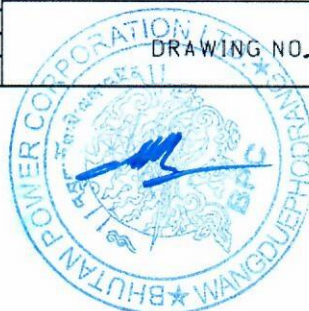



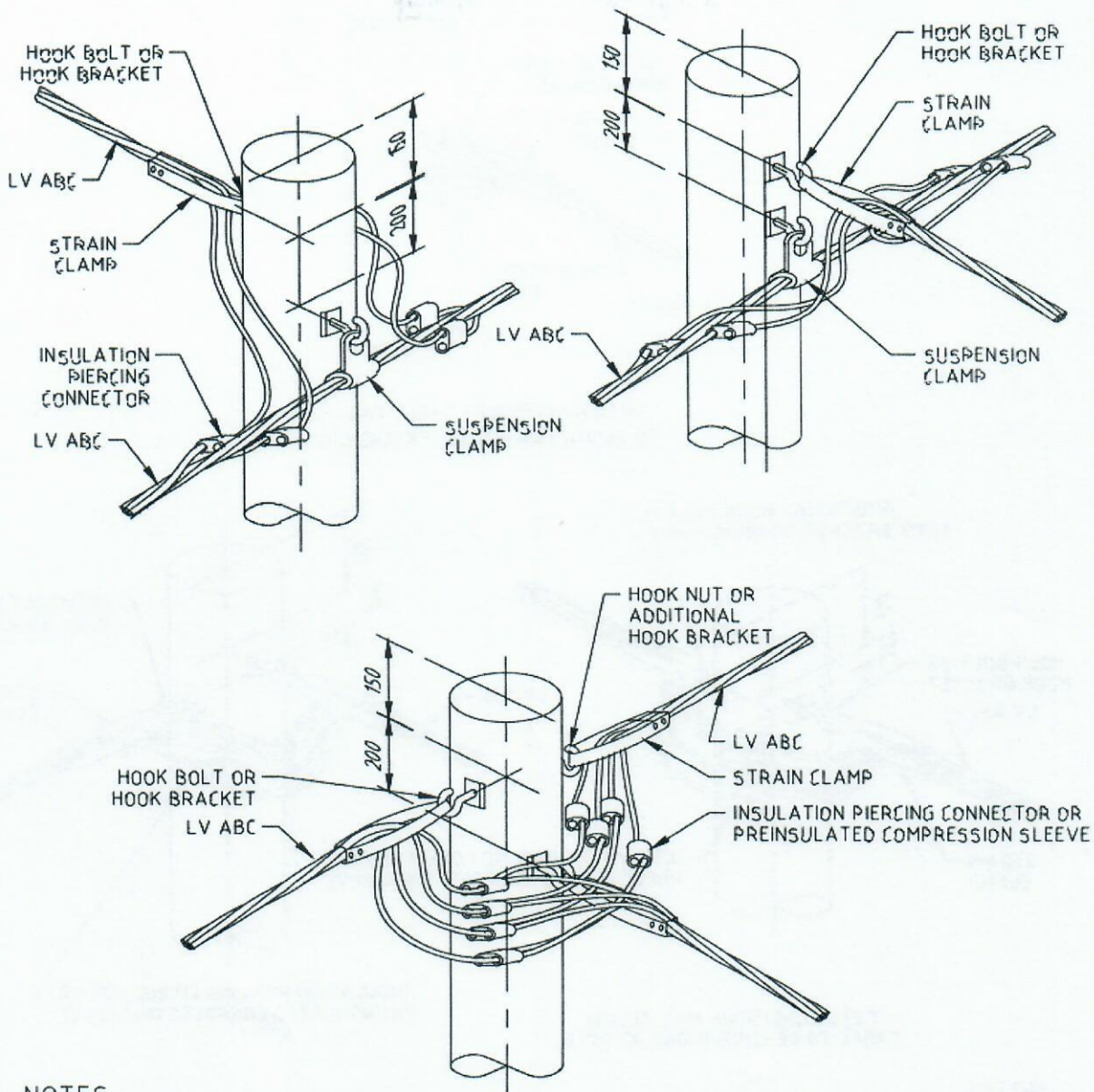

**NOTES**

1. DIMENSIONS AS SHOWN ARE IN mm.
2. DRAWING IS NOT TO SCALE.

	<b>BHUTAN POWER CORPORATION LIMITED</b>		<b>ENGINEERING DESIGN &amp; CONTRACTS DEPARTMENT</b>	
	DESIGNATION      NAME      DATE		<b>DISTRIBUTION DESIGN &amp; CONSTRUCTION STANDARD</b> <b>LV ABC TEE POLE DETAILS</b>	
DRAFTSPERSON			<b>DRAWING NO, BPC - DDCS - 2015-17</b>	
DESIGNER				
PROJECT MANAGER			<b>REVISION 2015</b>	
HEAD OF DEPARTMENT				



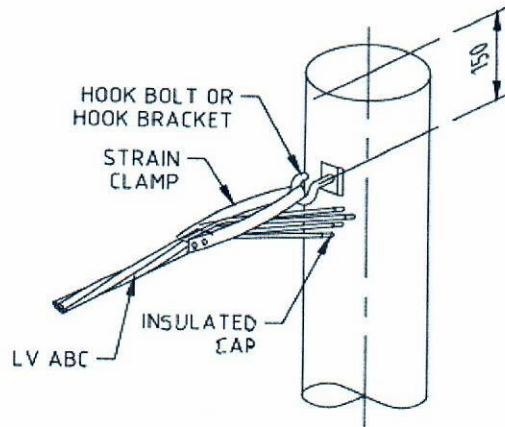

ALLOW SUFFICIENT CABLE TAIL  
TO ALLOW FOR FUTURE EXTENSION

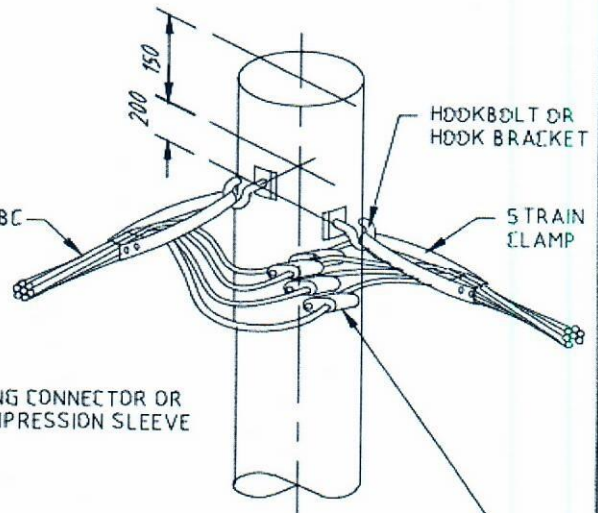
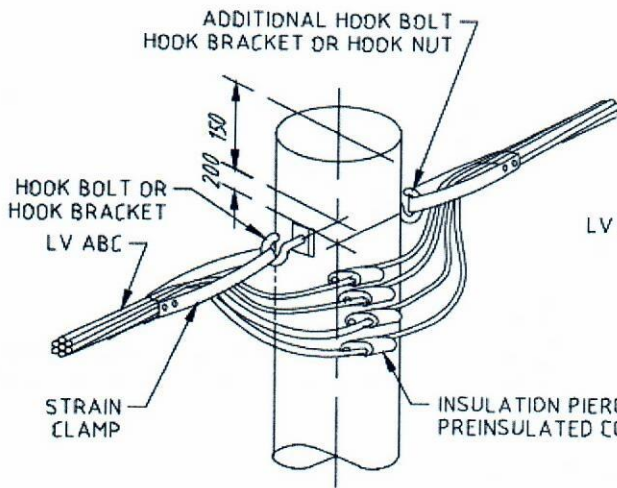

FIELD CONDITIONS MAY ALLOW  
CABLE TO BE CONTINUOUS AT POLE

**NOTES**

1. DIMENSIONS AS SHOWN ARE IN mm.
2. DRAWING IS NOT TO SCALE.



**BHUTAN POWER CORPORATION LIMITED**

**ENGINEERING DESIGN & CONTRACTS DEPARTMENT**

**TITLE : DISTRIBUTION DESIGN & CONSTRUCTION STANDARD  
LV ABC TERMINATION & ANCHOR POLES DETAILS**

DESIGNATION	NAME	DATE
DRAFTSPERSON		
DESIGNER		
PROJECT MANAGER		
HEAD OF DEPARTMENT		

**DRAWING NO. BPC / DDCS - 2015-16**

**REV  
2015**

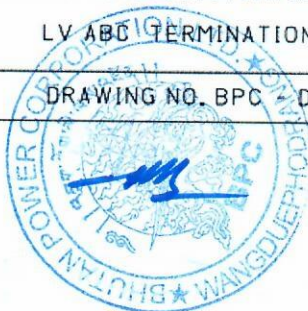

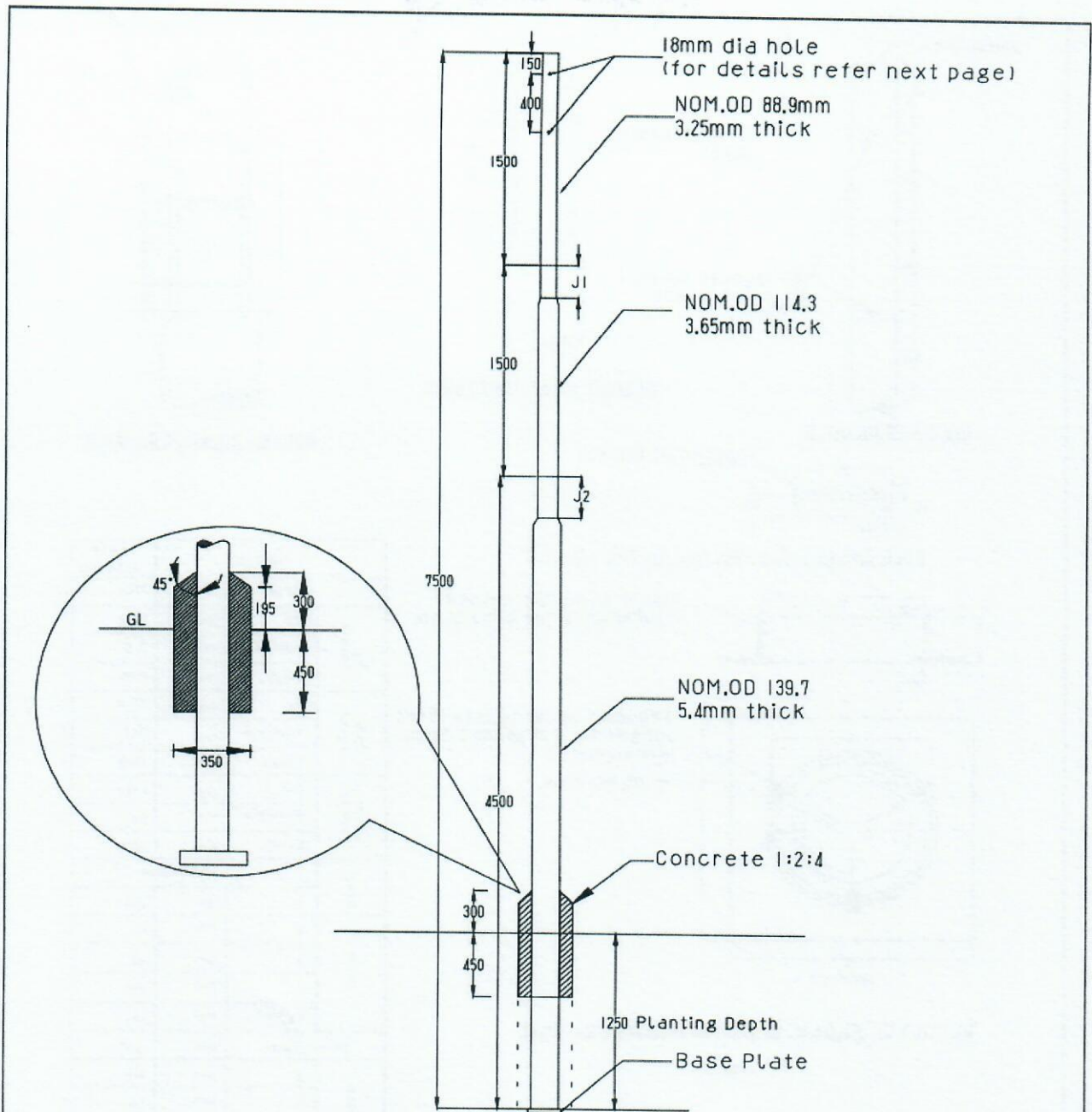

**NOTES**

1. DIMENSIONS AS SHOWN ARE IN MM.
2. SPECIFICATIONS AS PER IS:2713 (PART I TO III : 1980)
3. POLE TOP CAP -M.S. PLATE WOULD BE TAG WELDED TO THE POLE

 <b>BHUTAN POWER CORPORATION LIMITED</b>	ENGINEERING DESIGN & CONTRACTS DEPARTMENT	
	DISTRIBUTION DESIGN & CONSTRUCTION STANDARD	
DESIGNED BY	NAME	DATE
CHECKED BY		
APPROVED BY		
7.5 METERS SWAGED POLE ASSEMBLY		DRAWING NO. BPC-DDCS-2015-18
		REVISION 2015



NOM. OD 88.9mm



circumferential weld

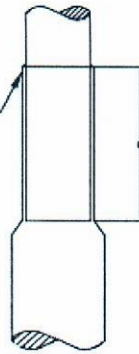

WELDED JOINT J1 DETAILS

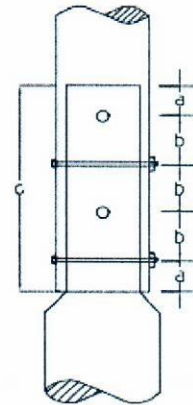

BOLTED JOINT J2 DETAILS

POLE TOP DETAILS

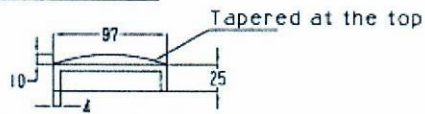

POLE CAP DETAILS (WELDED TO THE POLE)

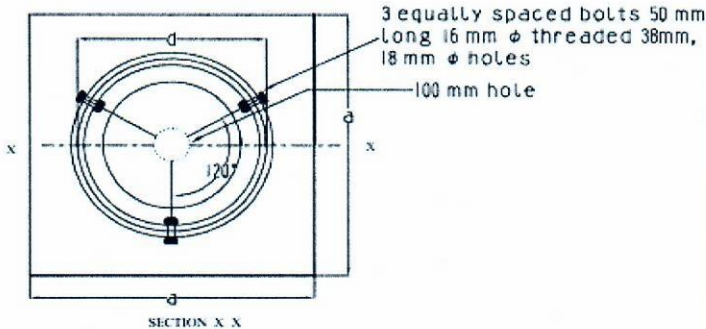
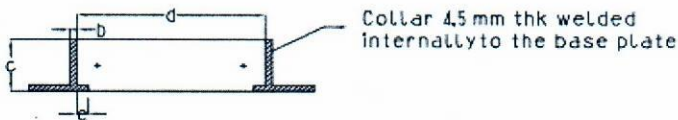

DETAILS OF MS BASE PLATE (Separately packed)

Pole Type		7.5 M (410-SP-9)	
Length		mm	7500
Top Segment	OD	mm	88.9
	Thickness	mm	3.25
	Length	mm	1500
Middle Segment	OD	mm	114.3
	Thickness	mm	3.65
	Length	mm	1500
Bottom Segment	OD	mm	139.7
	Thickness	mm	5.4
	Length	mm	4500
Joint -J1	Welded Joint		
	d	mm	230
Joint -J2	a	mm	45
	b	mm	70
	c	mm	300
	BL	mm	160
Planting Depth		mm	1250
Base plate details	a	mm	220
	b	mm	4.5
	c	mm	70
	d	mm	139.7
	e	mm	10

NOTES

1. DIMENSIONS AS SHOWN ARE IN MM.
2. DRAWING NOT TO SCALE.
3. SPECIFICATIONS AS PER IS:2713 (PART I TO III) : 1980
4. POLE TOP CAP -M.S. PLATE WOULD BE TAG WELDED TO THE POLE



BHUTAN POWER CORPORATION LIMITED

ENGINEERING DESIGN & CONTRACTS DEPARTMENT

DISTRIBUTION DESIGN & CONSTRUCTION STANDARD

7.5 METERS SWAGED POLE DETAILS

	NAME	DATE
DESIGNED BY		
CHECKED BY		
APPROVED BY		

DRAWING NO. BPC-DCS-2015-19

REVISION 2015

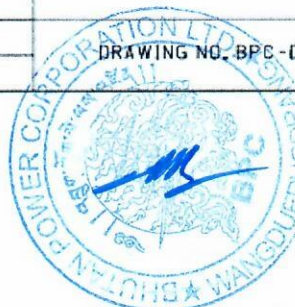

**ANCHOR ROD ASSEMBLY**

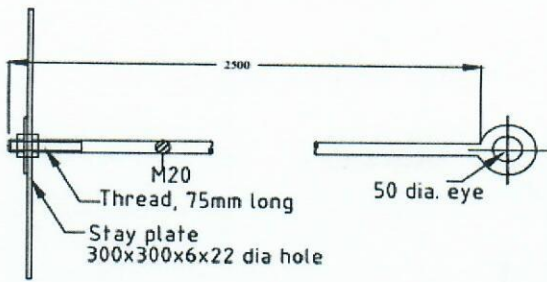

**TURN-BUCKLE ASSEMBLY**

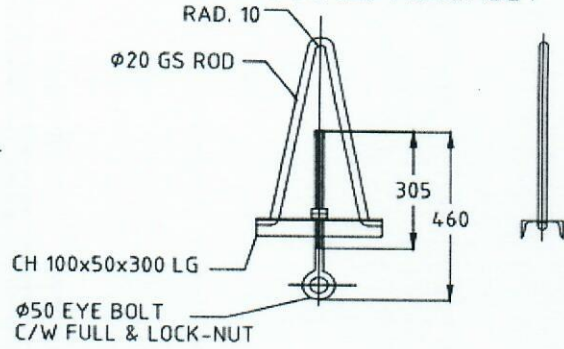

**STAY PLATE**

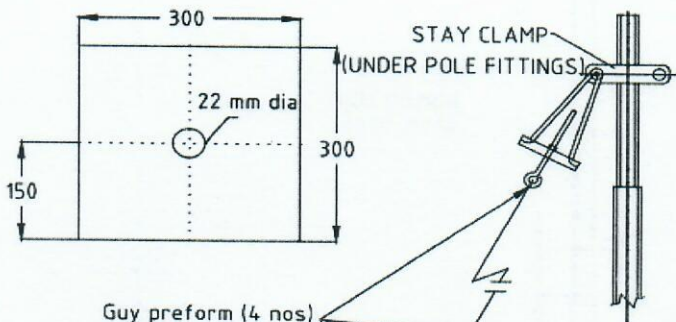

**EYE BOLT**

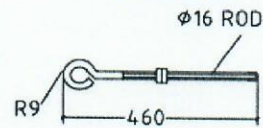

**V HANGER**

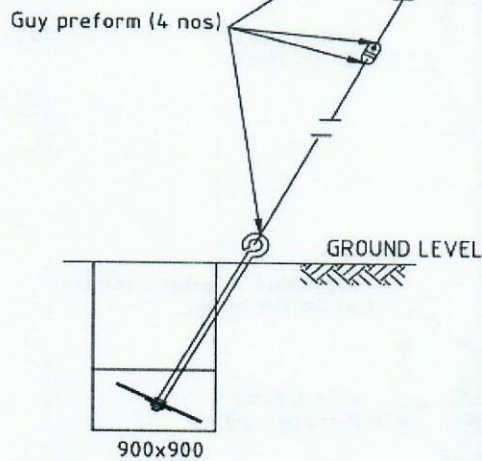
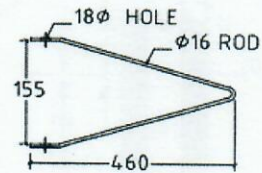

**STAY WIRE ASSEMBLY**

**NOTES**

Stay rod and nuts assembled and packed together  
 Anchor plates packed separately  
 Material :- BS 4360 Grade 43A  
 Galvanizing :- BS 729  
 Threads :- ISO Metric  
 Nut :- BS 4190 Grade 4.0

NAME OF THE ITEM	QTY	MATERIAL
V-HANGER ONLY FOR TELESCOPIC POLE	1	H.D.G STEEL
STAY WIRE (7/8 SWG) (IN METERS)	1M*POLE HEIGHT	H.D.G STEEL
STAY CLAMP WITH NUTS AND BOLTS	1	H.D.G STEEL
STAY ROD (2.5 M) WITH THIMBLE	1	H.D.G STEEL
ANCHOR PLATE (300 X 300 X 6MM)	1	H.D.G STEEL
TURN BUCKLE ASSEMBLY WITH THIMBLE	1	H.D.G STEEL
GUY PREFORMED SUITABLE FOR 7/8 SWG	4	GALVANISED STEEL WIRE
STAY INSULATOR	1	PORCELAIN



**BHUTAN POWER CORPORATION LIMITED**

**ENGINEERING DESIGN & CONTRACTS DEPARTMENT**

**DISTRIBUTION DESIGN & CONSTRUCTION STANDARD**

**STAY SET ASSEMBLY**

DESIGNATION	NAME	DATE
DRAFTSMAN		
DESIGNER		
DESIGN CHECK		
PROJECT MANAGER		
PROJECT DIRECTOR		

DRAWING NO. BPC-DDCS-2015-51

REVISION  
2015



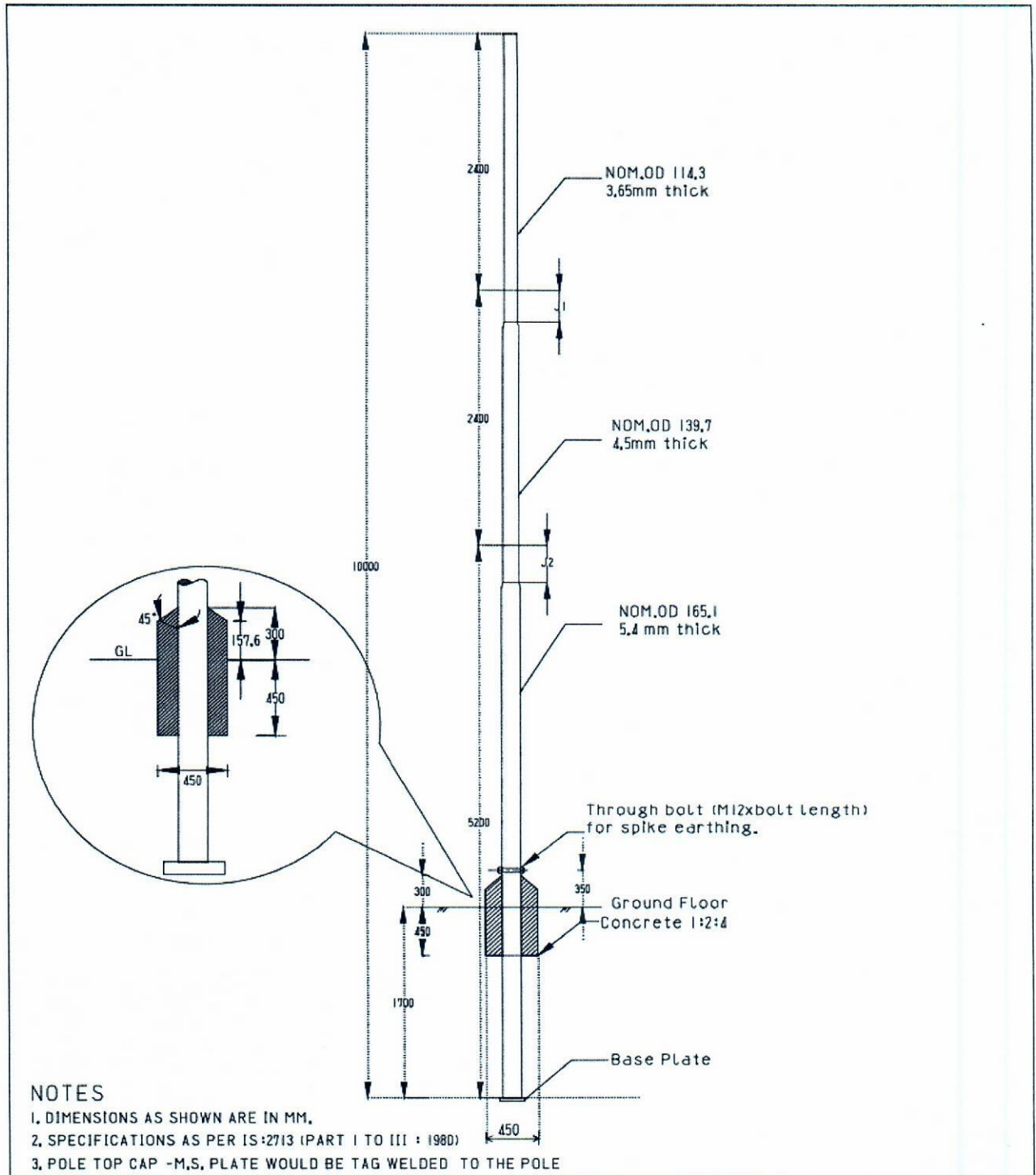

	<b>BHUTAN POWER CORPORATION LIMITED</b>		<b>ENGINEERING DESIGN &amp; CONTRACTS DEPARTMENT</b>		
			<b>DISTRIBUTION DESIGN &amp; CONSTRUCTION STANDARD</b>		
<b>DESIGNED BY</b>		<b>NAME</b>	<b>DATE</b>	<b>10 METER SWAGED POLE ASSEMBLY</b>	
<b>CHECKED BY</b>					
<b>APPROVED BY</b>					
			<b>DRAWING NO. BPC-DDCS-2015-20</b>	<b>REVISION 2015</b>	



## Material BOQ for Package B

### 1. Material for LV ABC (50 sq. mm) with steel tubular pole(RE-Fillin)

SI #	Particulars	Unit	Qty.
<b>Foreign Materials</b>			
1	Steel Tubular poles, 7.5 m. long with base plate, fixing bolts etc.	Nos.	168
2	LV ABC Conductor	km.	
2.1	For 4c-50 sq. mm	km.	5
2.2	For 2c-50 sq. mm	km.	3
3	G. I. Stay rod assembly (one turn buckle, one stay rod with base plate)	set	80
4	G. I. stay wire 7/8 SWG.	mtr.	680
5	Stay clamp assembly	nos.	80
6	Insulation tension jointing sleeves for 50 sq.mm	Nos.	10
<b>7 BOM for 40 nos. section/termination/ anchor pole</b>			
7.1	Hook Bolt Assembly for LV ABC Line with route bolt of 16 mm dia., 175 mm long.	nos.	40
7.2	Strain clamps / Dead End Clamp		
7.2.1	For 4c - 50 sq.mm LV ABC	nos.	30
7.2.2	For 2c - 50 sq.mm LV ABC	nos.	10
8	Insulation piercing connector or preinsulated compression sleeve	nos.	36
<b>9 BOM for 96 nos. intermediate poles and 16 nos. angle poles</b>			
9.1	Hook Bolt Assembly for LV ABC Line with route bolt of 16 mm dia., 175 mm long.	nos.	112
9.2	Suspension clamp - small angle		
9.2.1	For 4c - 50 sq.mm LV ABC	nos.	68
9.2.2	For 2c - 50 sq.mm LV ABC	nos.	28
9.3	Suspension clamp - large angle		
9.3.1	For 4c - 50 sq.mm LV ABC	nos.	10
9.3.2	For 2c - 50 sq.mm LV ABC	nos.	6
<b>10 BOM for 16 no. Tee pole</b>			
10.1	Hook Bolt Assembly for LV ABC Line with route bolt of 16 mm dia., 175 mm long.	nos.	16
10.2	Strain clamps / Dead End Clamp		
10.2.1	For 4c - 50 sq.mm LV ABC	nos.	10
10.2.2	For 2c - 50 sq.mm LV ABC	nos.	10
10.3	Suspension clamp - small angle		
10.3.1	For 4c - 50 sq.mm LV ABC	nos.	6
10.3.2	For 2c - 50 sq.mm LV ABC	nos.	6
10.4	Insulation piercing connector (IPC 50/50)	nos.	96

