

**BHUTAN POWER CORPORATION LIMITED  
DISTRIBUTION SERVICES  
DISTRIBUTION CONSTRUCTION DEPARTMENT  
THIMPHU: BHUTAN**



**BIDDING DOCUMENT FOR LABOUR  
CONTRACT OF GYALSUNG PROJECTS**

Tender No. BPC/DS/DCD/Gyalsung/01

## **CONTENTS:**

1. Integrity Pact
2. Section I - Invitation for Bids
3. Section II - Instructions to Bidders
4. Section III - Conditions of Contract
5. Section IV – Construction Standards & Technical Specifications and Drawings
6. Section V - Price Schedules
7. Section VI - Bid Form
8. Section VII - Other Forms
9. Sample Bill of Quantities

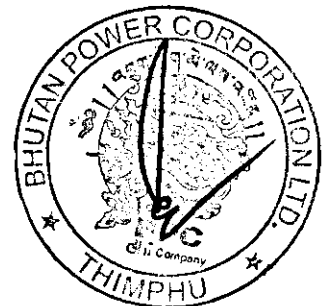

# INTEGRITY PACT

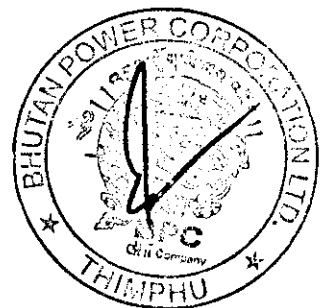

## INTEGRITY PACT

### 1 General:

Whereas, Mr. Drukchu Dorji, GM, DCD  
representing the Bhutan Power Corporation Limited, Royal Government of Bhutan,  
hereinafter referred to as the "Employer" on one part, and  
(Name of Bidder or  
his/her authorized representative, with power of attorney) representing  
M/s (Name of Firm) as  
the other part hereby execute this agreement as follows:

This agreement should be a part of the tender document, which shall be signed by both the parties at the time of purchase of bidding documents and submitted along with the tender documents. This IP is applicable only to "Small" scale works, goods and services, the threshold of which will be announced by the government from time to time. The signing of the IP shall not apply to framework contracting such as annual office supplies, etc.

### 2 Objectives:

Whereas, the Employer and the Bidder agree to enter into this agreement, hereinafter referred to as IP, to avoid all forms of corruption or deceptive practice by following a system that is fair, transparent and free from any influence/unprejudiced dealings in the **bidding process**<sup>1</sup> and **contract administration**<sup>2</sup>, with a view to:-

- 2.1 Enabling the Employer to obtain the desired contract at a reasonable and competitive price in conformity to the defined specifications of the works, goods or services; and
- 2.2 Enabling bidders to abstain from bribing or any corrupt practice in order to secure the contract by providing assurance to them that their competitors will also refrain from bribing and other corrupt practices

### 3. Scope

The validity of this IP shall cover the bidding process and contract administration period.

### 4. Commitments of the Employer:

The Employer Commits itself to the following:-

- 4.1 The Employer hereby undertakes that no official of the Employer, connected directly or indirectly with the contract, will demand, take a promise for or accept, directly or through intermediaries, any bribe, consideration, gift, reward, favour or any material or immaterial benefit or any other advantage from the Bidder, either for themselves or for any person, organization or third party related to the contract in exchange for an advantage in the bidding process and contract administration.

<sup>1</sup> Bidding process, for the purpose of this IP, shall mean the procedures covering tendering process starting from bid preparation, bid submission, bid processing, and bid evaluation.

<sup>2</sup> Contract Administration, for the purpose of this IP, shall mean contract award, contract implementation, unauthorized sub-contracting and contract handing/taking over.

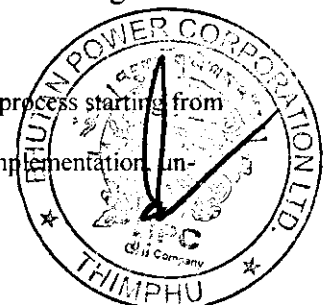

- 4.2 The Employer further confirms that its officials has not favored any prospective Bidder in any form that could afford an undue advantage to that particular Bidder in the bidding process and contract administration and will treat all Bidders alike.
- 4.3 Officials of the Employer, who may have observed or noticed or have reasonable suspicion shall report to the head of the employing agency or an appropriate government office any violation or attempted violation of clauses 4.1 and 4.2.
- 4.4 Following report on violation of clauses 4.1 and 4.2 by official(s), through any source, necessary disciplinary proceedings, or any other action as deemed fit, including criminal proceedings shall be initiated by the Employer and such a person shall be debarred from further dealings related to the bidding process and contract administration.

**5 Commitments of Bidders:**

The Bidder commits himself/herself to take all measures necessary to prevent corrupt practices, unfair means and illegal activities during any stage of the bidding process and contract administration in order to secure the contract or in furtherance to secure it and in particular commits himself/herself to the following:-

- 5.1 The Bidder shall not offer, directly or through intermediaries, any bribe, gift, consideration, reward, favor, any material or immaterial benefit or other advantage, commission, fees, brokerage or inducement to any official of the Employer, connected directly or indirectly with the bidding process and contract administration, or to any person, organization or third party related to the contract in exchange for any advantage in the bidding process and contract administration.
- 5.2 The Bidder shall not collude with other parties interested in the contract to manipulate in whatsoever form or manner, the bidding process and contract administration.
- 5.3 If the Bidder(s) have observed or noticed or have reasonable suspicion that the provisions of the IP have been violated by the procuring agency or other Bidders, the Bidder shall report such violations to the head of the procuring agency.

**6 Sanctions for Violation:**

The breach of any of the aforesaid provisions shall result in administrative charges or penal actions as per the relevant rules and laws.

- 6.1 The breach of the IP or commission of any offence (forgery, providing false information, mis-representation, providing false/fake documents, bid rigging, bid steering or coercion) by the Bidder, or any one employed by him, or acting on his/her behalf (whether with or without the knowledge of the Bidder), shall be dealt with as per the terms and conditions of the contract and other provisions of the relevant laws including De-barment Rules.
- 6.2 The breach of the IP or commission of any offence by the officials of the procuring agency shall be dealt with as per rules and laws of the land in vogue.

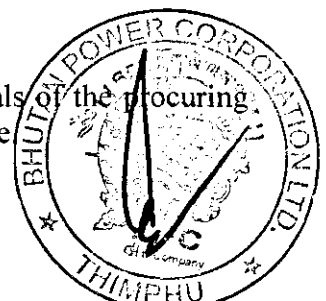

7. **Monitoring and Administration:**

- 7.1 The respective procuring agency shall be responsible for administration and monitoring of the IP as per the relevant laws.
- 7.2 The Bidder shall have the right to appeal as per the arbitration mechanism contained in the relevant rules.

We, hereby declare that we have read and understood the clauses of this agreement and shall abide by it.

The parties hereby sign this Integrity Pact at \_\_\_\_\_ on \_\_\_\_\_

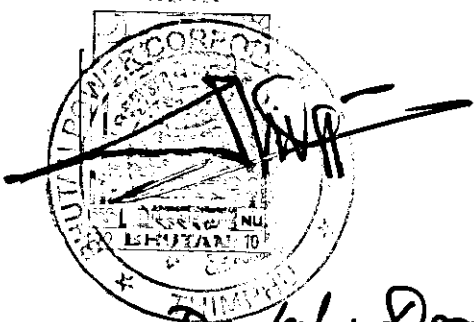

Affix  
Legal  
Stamp

EMPLOYER *Drukshu Dorji*  
CID: *11601000412*

BIDDER/REPRESENTATIVE  
CID:

Witness: *[Signature]*  
Name: *Ketzanng Yudon*  
CID: *11513002766*

Witness: \_\_\_\_\_  
Name:  
CID:

**SECTION I**  
**INVITATION FOR BIDS**

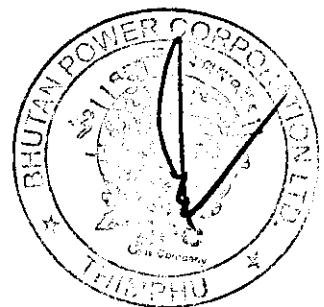

## INVITATION FOR BIDS

Date: May 24, 2021

Tender No.: BPC/DS/DCD/Gyalsung/01

1. BPC invites sealed bids from the below mentioned Class categories of Bhutanese National with W4 (Power and telecommunications) valid License and registered with the Construction Development Board for construction of electricity distribution infrastructure works under the following packages.

| Sl. No | Dzongkhags            | Package Name | Bid Security Amount (Nu.) | Contractor's Classification |
|--------|-----------------------|--------------|---------------------------|-----------------------------|
| 1      | Bondeyma, Mongar      | A            | 58,486.00                 | Small                       |
| 2      | Pemathang, S/Jongkhar | B            | 69,024.00                 | Small                       |

2. Interested eligible Bidders may obtain further information from and inspect the bidding documents at the office of :

**General Manager,  
Distribution Construction Department,  
Bhutan Power Corporation Limited,  
Chubachu: Thimphu.  
Telephone No. +975-2-335931 Ext 846  
Mobile No. +975 17756471**

3. A complete set of bidding documents may be purchased by interested Bidder upon submission of an appropriate written application to the address above and upon payment of a non-refundable fee of Nu. 1,000.00 (Ngultrum one thousand only) together with copies of valid trade license, CDB's registration certificate and tax clearance certificate. The sale of bidding documents will be from **May 24, 2021** to **June 23, 2021** (Till 17:00 Hours).
4. Requires that Bidders, as a condition to admission to eligibility, execute and attach to their Bids an Integrity Pact statement in the form provided in the instruction to Bidder.
5. Bids must be delivered to the above office at or before 13:00 hours on **June 24, 2021** and must be accompanied by a Bid Security amount mentioned against individual package above in Bhutanese Ngultrum (Nu.).
6. Bids will be opened in the presence of Bidder or Bidder(s)' representatives who choose to attend at 14:30 hours on **June 24, 2021** at the Conference Hall of Bhutan Power Corporation Limited, Yarden Lam, Chubachu, Thimphu, Bhutan.
7. BPC will not be responsible for any expenses incurred by Bidders in connection with the

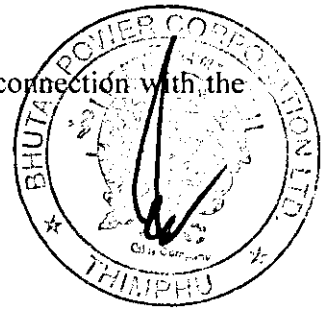



preparation or delivery of bids.

8. The prospective Bidders could view the bidding documents in the purchaser's website [www.bpc.bt](http://www.bpc.bt). Bidding documents can be also downloaded from the Purchaser's website but should register with the Purchaser on or before the closing of Bid Sale Date (Before 17:00 hours on June 23, 2021) after paying registration fee of Nu. 200.00 (Ngultrum two hundred) only.

The registration shall be done through written application together with valid trade license, CDB's registration certificate and tax clearance certificate. The Bidders should bind the downloaded and printed binding document properly. Bidder's qualification criteria are stipulated in the Instructions to Bidders of the bidding documents.

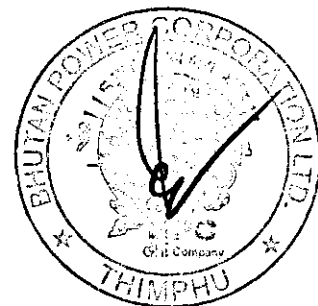

# **SECTION II**

## **INSTRUCTIONS TO BIDDERS**

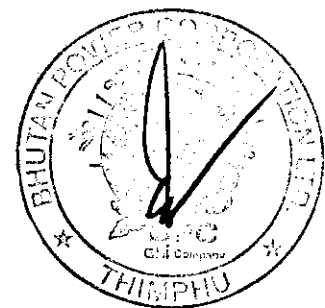

## TABLE OF CONTENTS

|   |    |
|---|----|
| <b>Section-II</b> .....   | 1  |
| <b>Instructions to Bidders</b> .....  | 1  |
| <b>A. General</b> .....   | 1  |
| 1. Scope of Bid .....   | 1  |
| 2. Eligible Bidders.....  | 1  |
| 3. Cost of Bidding and Site Visit.....  | 2  |
| 4. Pre-bid Meeting.....   | 3  |
| <b>B. The Bidding Documents</b> .....   | 3  |
| 5. Bidding Documents.....   | 3  |
| 6. Clarification of Bidding Documents.....  | 3  |
| 7. Amendments of Bidding Documents.....   | 4  |
| <b>C. Preparation of Bids</b> .....   | 4  |
| 8. Language of Bid.....   | 4  |
| 9. Documents Comprising the Bid.....  | 4  |
| 10. Bid Form.....   | 4  |
| 11. Bid Prices.....   | 5  |
| 12. Bid Currencies.....   | 5  |
| 13. Documents Establishing Eligibility of the Bidder.....                                   | 5  |
| 14. Documents Establishing the Bidder's Qualifications to Perform the Contract.....         | 6  |
| 15. Documents Establishing the Goods' and Services Conformity to the Bidding Documents..... | 6  |
| 16. Bid security.....   | 6  |
| 17. Period of Validity of Bids.....   | 7  |
| 18. Alternative Bids.....   | 8  |
| 19. Format and Signing of Bid.....  | 8  |
| <b>D. Submission of Bids</b> .....  | 8  |
| 20. Sealing and Marking of Bids.....  | 8  |
| 21. Deadline for Submission of Bids.....  | 9  |
| 22. One Bid per Bidder.....   | 9  |
| 23. Late Bids.....  | 10 |
| 24. Modification and Withdrawal of Bids.....  | 10 |
| <b>E. Bid Opening and Evaluation</b> .....  | 10 |
| 25. Opening of Bids by Employer.....  | 10 |
| 26. Process to be Confidential.....   | 11 |
| 27. Clarification of Bids.....  | 11 |
| 28. Preliminary Examination of Bids.....  | 11 |
| 29. Conversion to Ngultrum.....   | 12 |

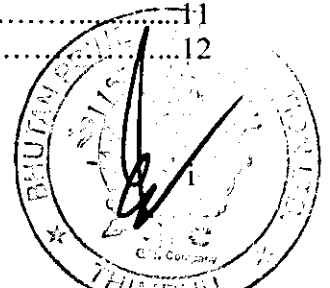

|           |   |           |
|-----------|---|-----------|
| 30.       | Evaluation and Comparison of Bids.....                                | 12        |
| 31.       | Contacting the Employer.....  | 13        |
| 32.       | Employer's Right to Accept Any Bid and to Reject Any or All Bids..... | 13        |
| <b>F.</b> | <b>Award of Contract.....</b>   | <b>13</b> |
| 33.       | Award.....  | 13        |
| 34.       | Employer's Right to Vary Quantities at Time of Award .....            | 14        |
| 35.       | Notification of Award.....  | 14        |
| 36.       | Signing of Contract.....  | 14        |
| 37.       | Performance Security.....   | 15        |
| 38.       | Corrupt or Fraudulent Practices .....                                 | 15        |
| 39.       | Labour .....  | 16        |
| 40.       | Equal Pay .....   | 16        |
| 41.       | Contractor Information Network (CiNET).....                           | 16        |

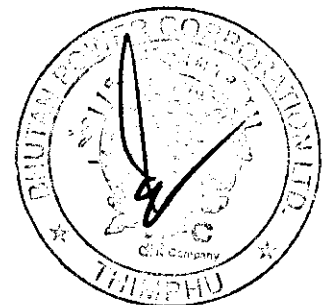

## SECTION II

### INSTRUCTION TO BIDDERS

#### General

#### 1. Scope of Bid

Bhutan Power Corporation Limited (BPC) (hereafter referred to as "the Employer") wishes to receive sealed Bids for Labour Contract of Electrical Works in Mongar & Samdrup Jongkhar Dzongkhags. The scope of works include construction, erection, testing, commissioning of MV lines including loading, transportation, delivery of all materials and equipment to sites, storage, tree felling, clearance of ROW, etc. (hereinafter referred to as "Works"). The works are classified under the following packages.

| SI # | Package | Name of works  |
|------|---------|--|
| 1    | A       | Construction of 33 kV line with ACSR, conductor (DOG) and shield wire on Telescopic pole to Gyalsung Project, Bondeyma, Mongar.            |
| 2    | B       | Construction of 33 kV line with ACSR, conductor (DOG) and shield wire on Telescopic pole to Gyalsung Project, Pemathang, Samdrup Jongkhar. |

1.2 "Bidders may submit bids for one, any combination, or all of the packages", depending on own capabilities, as explained in Sub-Clause 30.6 of Instruction to Bidders.

1.3 The successful Bidder will be expected to complete the works within the stipulated time from the date of commencement of works as indicated in Article III, Clause No.11 of Conditions of Contract.

#### 2. Eligible Bidders

2.1 This Invitation for Bids is open to Small Class Bhutanese registered Contractors with W4 (Power and telecommunications) valid Trade License and Construction Development Board registration.

2.2 Bidders shall provide such evidence of their eligibility satisfactory to the Employer, as the Employer shall reasonably request.

2.3 A Bidder shall not have a conflict of interest. All Bidders found to have conflict of interest shall be disqualified. Bidders may be considered to have a conflict of interest with one or more parties in this bidding process, if:

- (a) they have a relationship with each other, directly or through third parties, that puts them in a position to have access to information about or influence on the Bid of

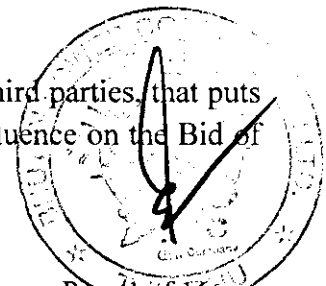

another Bidder, or influence the decisions of the Employer regarding this bidding process; or

- (b) Bidder or any of its affiliates participated as a consultant in the preparation of the design or technical specifications of the Works that are the subject of the Bid or in any other way provided consulting services in any aspect of the preparatory stages leading up to the issue of these bidding documents; or
- (c) Bidder lends, or temporarily seconds its personnel to firms or organizations which are engaged in consulting services for the preparation related to procurement for or implementation of the project, if the personal would be involved in any capacity on the same project.

### 3. Cost of Bidding and Site Visit

- 3.1 The Bidder shall bear all costs associated with the preparation and delivery of its Bid, and the Employer will in no case be responsible or liable for those costs.
- 3.2 The Bidders, at their own responsibility and risk, is advised to visit and examine the Site and obtain all information that may be necessary for preparing the bid and entering into a Contract for performance of the Works. The costs of visiting the Site shall be at the bidder's own expense and at his own risk. The Project Manager, Gyalsung Project Office in respective Dzongkhags will facilitate the site visit to the interested bidders. The Bidder shall make appointment for field visit and the contact person(s) for the visits shall be as below.

| SI# | Place                | No. of Days | Date         |               | Contact Person              | Contact no. |
|-----|----------------------|-------------|--------------|---------------|-----------------------------|-------------|
|     |                      |             | From         | To            |                             |             |
| 1   | Bondeyma, Mongar     | 5           | May 24, 2021 | June 20, 2021 | Mr. Sonam Tshering, PM, GPO | 17456917    |
| 2   | Pemathang S/Jongkhar | 5           | May 24, 2021 | June 20, 2021 | Ms. Karma Chheki, PM, GPO   | 17151124    |

- 3.3 The Bidders and any of their personnel or agents will be granted permission by the Employer to enter upon its premises and land for the purpose of such inspection, but only upon the condition that the Bidders, their personnel and agents, will release and indemnify the Employer and its personnel and agents from and against all liability in respect thereof and will be responsible for death or personal injury, loss of or damage to property and any other loss, damage, costs and expenses incurred as a result of the inspection.

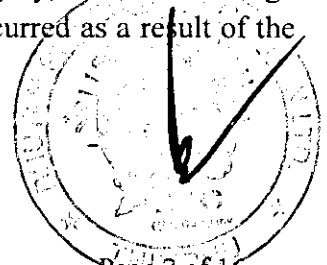

**4. Pre-bid Meeting**

4.1 Not Applicable.

**B. The Bidding Documents**

**5 Bidding Documents**

5.1 The bidding procedures and contract terms are prescribed in the bidding documents. In addition to the Invitation for Bids, the bidding documents include:

- I Integrity Pact
- II Instructions to Bidders;
- III Conditions of Contract;
- IV Technical Specifications and Drawings;
- V Price Schedules and Sample Bill of Quantities;
- VI Bid Form; and
- VII Sample Forms

- Bid Security Form
- Contract Form
- Performance Security Form
- Bank Guarantee for Advance Payment
- Form of Information for Establishment of Bidder's Eligibility
- Form of Information for Establishment of Bidder's Qualification
- Confirmation of Litigation History

VIII Any amendments.

5.2 The Bidders are expected to examine the bidding documents, including all instructions, forms, terms and specifications. Failure to furnish all information required by bidding documents or submission of a Bid not substantially responsive to the bidding documents in every respect will result in the rejection of the Bid.

**6. Clarification of Bidding Documents**

6.1 Prospective Bidders requiring any further information or clarification of the bidding documents may notify the Employer in writing at the Employer's mailing address indicated under Clause 20.2. The Employer will respond in writing to any request for information or clarification of the bidding documents, which it receives no later than ten (10) days prior to the submission of Bids. The Employer's response including an explanation to the query will be sent in writing to all prospective Bidders who purchased the bidding documents.

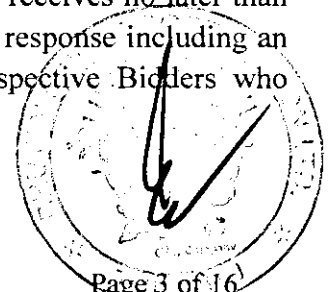

**7. Amendments of Bidding Documents**

- 7.1 At any time prior to the deadline for submission of Bids, the Employer may, for any reason, whether at its own initiative or in response to a clarification requested by prospective Bidder, modify the bidding documents by issuing addendum.
- 7.2 The amendment shall be part of the bidding documents, pursuant to Sub-Clause 5.1, and it will be notified in writing or by fax to all prospective Bidders who have received the bidding documents, and will be binding on them.
- 7.3 In order to afford prospective Bidders reasonable time in which to take the amendment into account in preparing their Bids, the Employer may, at its discretion, extend the dead line for the submission of Bids.

**C. Preparation of Bids.**

**8. Language of Bid**

- 8.1 The Bids prepared by the Bidder, and all correspondence and documents relating to the Bid exchanged by the Bidders and the Employer, shall be written in the English language.

**9 Documents Comprising the Bid**

- 9.1 The Bid prepared by the Bidders shall comprise of the following components:
  - (a) Bid Form and Price Schedule completed in accordance with Clause 10, 11, 12;
  - (b) Documentary evidence establishing, in accordance with Clause 13, that the Bidder is eligible to bid.
  - (c) Documentary evidence establishing in accordance with Clause 14, that the Bidder is qualified to perform the Contract if it's Bid is accepted;
  - (d) Bid security furnished in accordance with Clause 16.
  - (e) Written power-of-attorney authorizing the signature by Bidders in accordance with Clause 19.2.

**10 Bid Form**

- 10.1 The Bidder shall complete **an original and (two) copies of the Bid Form and the appropriate Price Schedules** furnished in the bidding documents.

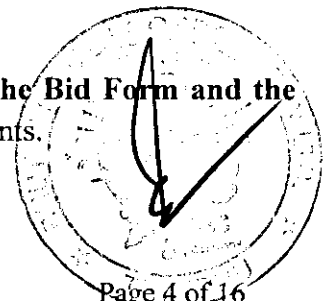



Bid forms not duly filled and signed and sealed appropriately shall be treated as non-responsive and the Bid shall be rejected.

## 11 Bid Prices

11.1 The Bidder shall have the option to quote all the packages or one package. The bid will be evaluate package wise and awarded package wise.

However, BPC reserves the right to award only one package to the successful bidder.

11.2 The Bidder shall complete the appropriate Price Schedules included herein, stating the unit prices, total price per item and the total amount. Prices quoted shall follow strictly the format provided herein.

11.3 Unless stated otherwise in the bidding documents, the Contract shall be for the whole package, based on the schedule of unit rates and prices submitted by the Bidder.

11.4 The Bidder shall fill in rates and prices for all items of the works described in the Bill of Quantities. Items against which no rate or price is entered by the Bidder will not be paid for by the Employer when executed and shall be deemed covered by the other rates and prices in the Bill of Quantities.

11.5 All duties, taxes and other levies payable by the Contractor under the Contract, or any other cause, as of the date seven days (7) days prior to the deadline for submission of Bids shall be included in the rates and prices and the total bid price submitted by the Bidder.

11.6 Rates quoted by the Bidder shall remain fixed and valid until completion of the Contract performance and will not be subject to variation on any account. A Bid submitted with **price adjustment condition** will be treated as non-responsive and will be rejected.

11.7 Conditional tenders shall be rejected without any further explanation.

## 12 Bid Currencies

12.1 Rates shall be quoted in Ngultrum.

## 13 Documents Establishing Eligibility of the Bidder.

13.1 The Bidder shall furnish, as part of its Bid, certification establishing the Bidder's eligibility to bid pursuant to Clause 2.

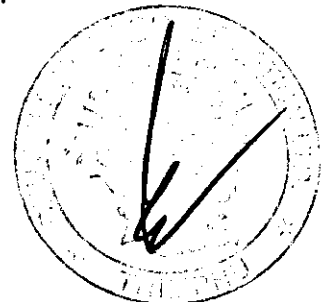

13.2 The Bidder is a registered qualified for W4 Contractors. If in case, the license and the CDB registration certificate have expired during the bid submission, the Bidder shall submit letters from competent authorities validating the documents.

13.3 The Bidder does not anticipate change in ownership during the proposed period of work (if such a change is anticipated, the scope and effect thereof shall be defined).

13.4 The Bidder shall submit proposals of work method and schedule, in sufficient detail to demonstrate the competency of the Bidder's proposals to meet the completion schedule referred to in Sub-Clause 1.3 above.

**14. Documents Establishing the Bidder's Qualifications to Perform the Contract**

14.1 The technical qualification of the Bidder to perform the required works is the most important criteria and each Bidder shall submit the duly filled Form No.6 in Section VII. A minimum of one site supervisor with electrical Diploma/RTI/VTI/NC2 with qualification certificate shall be submitted with the Bid. The supervisor shall be proposed as the Accident Prevention Officer or separate personnel who have sufficient experience shall be submitted. Form No.6 must be accompanied with the qualification certificate.

14.2 The Bidder shall provide in Form No.6 in Section VII, a list of tools and equipment related to the works including vehicles to show that the Bidder has enough tools and equipment to execute the work immediately.

**15 Documents Establishing the Goods' and Services Conformity to the Bidding Documents**

15.1 Not applicable.

**16 Bid security**

16.1 The Bidder shall furnish, as part of its Bid, a bid security in the amount as given below.

| Sl. No | Place                       | Package Name | Bid Security Amount (Nu.) | Contractor's Classification |
|--------|-----------------------------|--------------|---------------------------|-----------------------------|
| 1      | Bondeyma, Mongar            | A            | 58,486.00                 | Small                       |
| 2      | Pemathang, Samdrup Jongkhar | B            | 69,024.00                 | Small                       |

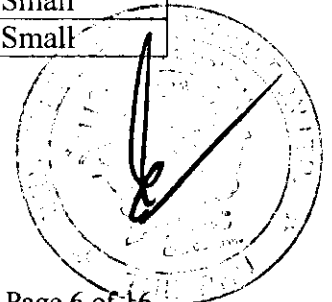

- 16.2 The bid security shall be denominated in the currency of the Bid. It shall be valid for thirty days (30) beyond the validity of the Bid (i.e. **October 22, 2021**) and shall be in one of the following forms acceptable to the Employer:
- (a) Cash Warrant/Bank Draft/Bank Guarantee issued by a reputable bank in Bhutan acceptable to the Employer in the form provided in the bidding documents or another form subject to prior approval of the Employer.
  - (b) The Bank Guarantee shall be drawn in favour of Director, Finance & Accounts Services, Bhutan Power Corporation Limited, Thimphu, Bhutan.
  - (c) Cash, personal cheque, etc., will not be accepted as a bid security and the Bid will be treated as non-responsive and will be rejected.
- 16.3 Any Bid not secured in accordance with Sub-Clause 16.1 and 16.2 above will be treated as non-responsive and will be rejected.
- 16.4 The unsuccessful Bidder's bid security will be discharged/returned as promptly as possible upon award of Contract to the successful Bidder, but in any event not later than thirty (30) days after the expiration of the period of bid validity.
- 16.5 The successful Bidder's bid security will be discharged/returned upon furnishing the performance security and the Bidder's executing the Contract.
- 16.6 The bid security may be forfeited:
- (a) if the Bidder withdraws its Bid during the period of the bid validity specified by the Bidder on the Bid Form; or
  - (b) if the Bidder does not accept the correction of its bid prices; or
  - (c) in the case of a successful Bidder, if the Bidder fails to comply with the specified time limit to
    - (i) sign the Contract; or
    - (ii) furnish the performance security.

## 17. Period of Validity of Bids

- 17.1 Bids shall remain valid for a period of **90 days (i.e. September 22, 2021)** from the date of opening of Bids.

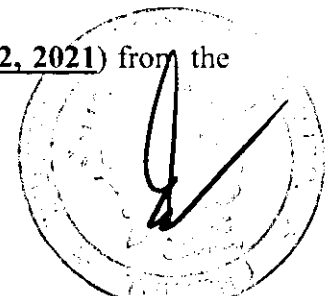

17.2 Notwithstanding Sub-Clause 17.1 above, the Employer may solicit Bidder's consent to an extension of the period of bid validity. The request and the responses thereto shall be made in writing or by fax. If the Bidder agrees to the extension request, the validity of the bid security provided under Clause 16 shall also be suitably extended. A Bidder may refuse the request without forfeiting its bid security. A Bidder agreeing to the request will not be required or permitted to modify its Bid, but will be required to extend the validity of its bid security for the period of the extension, and in compliance with Clause 16 in all respects.

**18 Alternative Bids**

18.1 Not applicable.

**19 Format and Signing of Bid**

19.1 The Original Bid Form and accompanying documents (as specified in Clause 10), clearly marked "**Original Bid**", plus "**Two (2) copies**" must be received by the Employer at the date, time and place specified pursuant to Clause 20 and 21. In the event of any discrepancy between the original and the copies, the original will govern.

19.2 The original and the copies of the Bid shall be typed or written in indelible ink and shall be signed by the Bidder or a person or persons duly authorized to sign on behalf of the Bidder. Such authorization shall be by a written Power of Attorney accompanying the Bid. If the Bid is not accompanied by the written Power of Attorney, the Bid will be treated as non-responsive and will be rejected. All pages of the Bid, except for un-amended printed literature, shall be initialed by the person or persons signing the Bid. The name and position held by each person signing must be typed or printed below the signature.

19.3 The Bid shall contain no interlineations, erasures or overwriting except as necessary to correct errors made by the Bidder, in which case such corrections shall be initialed by the person or persons signing the Bid.

**D. Submission of Bids**

**20. Sealing and Marking of Bids**

20.1 The Bidder shall seal the original and each copy of the Bid in an inner and an outer envelope, duly marking the envelopes as "**Original**" and "**Copy**". The outer envelope shall be marked "**Confidential**".

20.2 The inner and outer envelopes shall:

(a) be addressed to the Employer at the following address:

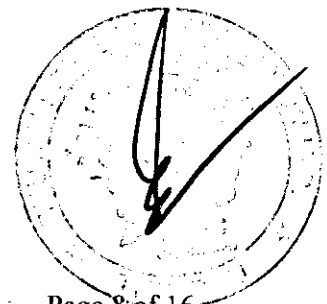

**General Manager,  
Distribution Construction Department,  
Bhutan Power Corporation Limited,  
Yarden Lam, Chubachu: Thimphu  
Telephone No. +975-2-335931 Ext 846;  
Mobile No. +975 17756471**

(b) bear the following identification:

**Bid Reference No. BPC/DS/DCD/Gyalsung/01**

**DO NOT OPEN BEFORE 14:30 hours on June 24, 2021**

In addition to the identification required in Sub-Clause 20.2, the inner envelope indicate the name and address of the Bidder to enable the Bid to be returned unopened in case it is declared "Late" pursuant to Clause 23.

20.3 If the outer envelope is not sealed and marked as required by Sub-Clause 20.1 and 20.2, the Employer will assume no responsibility for the Bid misplacement or premature opening.

**21 Deadline for Submission of Bids**

21.1 The original Bid, together with the required copies, must be received by the Employer at the address specified in Sub-Clause 20.2 no later than 13:00 hours on **June 24, 2021**.

21.2 The Employer may, at its discretion, extend the deadline for the submission of Bids by issuing an addendum in accordance with Clause 7, in which case all rights and obligations of the Employer and the Bidders previously subject to the deadline will thereafter be subject to the deadline as extended.

21.3 Bidders or their authorized representatives only, shall be allowed to attend the bid opening. Procuring Agency shall ensure and include in the bid document that the bidder's representative attending the bid opening shall have an Authorization Letter from the bidder, without which the representative shall not be permitted to attend the bid opening. Each Bidder will be allowed only one representative to attend the Bid opening.

**22. One Bid per Bidder**

22.1 Each Bidder shall submit only one Bid individually and no Joint Venture/Consortium is acceptable. A Bidder who submits or participates in more than one Bid will be disqualified.

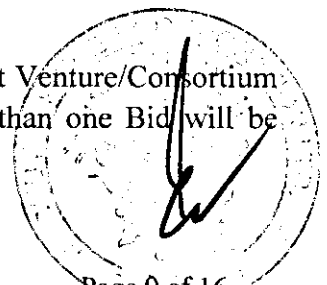

**23. Late Bids**

23.1 Any Bid received by the Employer after the deadline for submission of Bids prescribed by the Employer, pursuant to Clause 21, will be declared “Late” and rejected and returned unopened to the Bidder.

**24. Modification and Withdrawal of Bids**

24.1 The Bidder may modify or withdraw its Bid after the Bid’s submission, provided that written notice of the modification or withdrawal is received by the Employer prior to the deadline prescribed for submission of Bids.

24.2 The Bidder’s modification or withdrawal notice shall be prepared, sealed, marked and delivered in accordance with provisions of Clause 20, with the outer and inner envelopes additionally marked “MODIFICATION” or “WITHDRAWAL”, as appropriate. A withdrawal notice may also be sent by fax but must be followed by signed confirmation copy.

24.3 No Bid may be modified by the Bidder after the deadline for submission of Bids.

24.4 Withdrawal of a Bid during the interval between the deadline for submission of Bids and the expiration of the period of bid validity specified in the Form of Bids may result in the forfeiture of the Bid Security pursuant to Clause 16.

24.5 Bids requested to be withdrawn in accordance with Clause 24.1 shall be returned unopened to the Bidders.

**E. Bid Opening and Evaluation**

**25. Opening of Bids by Employer**

25.1 The Employer will open Bids, including modifications made pursuant to Clause 24, in the presence of Bidder or Bidder(s)’ representatives who choose to attend at 14:30 hours on June 24, 2021 in the **Conference Hall of Bhutan Power Corporation Limited, Yarden Lam, Chubachu, Thimphu**. The Bidder or Bidder(s)’ representatives who are present shall sign a register evidencing their attendance.

25.2 Envelopes marked “WITHDRAWAL” shall be opened and read out first. Bids for which an acceptable notice of withdrawal has been submitted pursuant to Clause 24 shall not be opened, but returned to the Bidder.

25.3 The Bidders’ names, prices of Bids, all discounts offered, modifications and Bid withdrawals, and the presence or absence of the requisite bid security, and such other

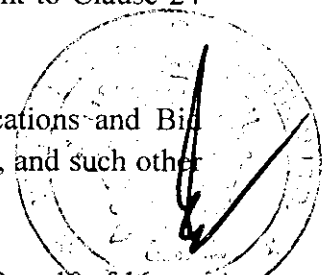

details as the Employer, at its discretion, may consider appropriate will be announced and recorded at the time of opening. Any Bid Price, or discount which is not read out and recorded at Bid opening will not be taken into account in Bid evaluation. No Bid shall be rejected at bid opening except for late Bids, in accordance with Clause 23.1.

## **26 Process to be Confidential**

26.1 Information relating to the examination, clarification, evaluation and comparison of Bids and recommendations for the award of a Contract shall not be disclosed to Bidders or any other persons not officially concerned with such process. Any effort by a Bidder to influence the Employer's processing of Bids or award decision may result in the rejection of the Bidder's Bid.

## **27. Clarification of Bids**

27.1 To assist in the examination, evaluation and comparison of Bids, the Employer may, at its discretion, ask the Bidder for a clarification of its Bid. All requests for clarification and the responses shall be in writing, and no change in the price or substance of the Bid shall be sought, offered or permitted except as required to confirm the correction of arithmetic errors discovered by the Employer in the evaluation of the Bids in accordance with Clause 28.4.

## **28. Preliminary Examination of Bids**

28.1 The Employer will examine the Bids to determine whether they are complete, whether any computational errors have been made, whether required sureties have been furnished, whether the documents have been properly signed, and whether the Bids are generally in order.

28.2 Prior to the detailed evaluation, pursuant to Clause 30, the Employer will determine the substantial responsiveness of each Bid to the bidding documents. A substantially responsive Bid is one which conforms to all the terms and conditions of the bidding documents without material deviation or reservation. A material deviation, reservation, or omission is one;

- (i) which affects in any substantial way the scope, quality, completion schedule or performance of the Works;
- (ii) which limits in any substantial way, inconsistent with the provision of the bidding documents, the Employer's rights or the Bidder's obligations under the Contract; or
- (iii) Whose rectification would affect unfairly the competitive position of other Bidders presenting substantially responsive Bids.

28.3 A Bid determined as not substantially responsive will be rejected by the Employer and may not subsequently be made responsive by the Bidder by correction of the non-conformity.

28.4 Arithmetical errors will be rectified on the following bases;

(i) If there is a discrepancy between the unit price and the total price per item that is obtained by multiplying the unit price and the quantity, the unit price shall prevail and the total price per item will be corrected.

(ii) If there is a discrepancy between the Total Amount and the sum of the total price per item, the sum of the total price per item shall prevail and the Total Amount will be corrected.

28.5 The amount stated in the Form of Bid will be adjusted by the Employer in accordance with the above procedure for the corrections of errors and, shall be considered as binding upon the Bidder. If the Bidder does not accept the corrected amount to Bid, its Bid will be rejected, and the bid security will be forfeited.

## **29. Conversion to Ngultrum**

29.1 The Bid Price shall be in Ngultrum.

## **30. Evaluation and Comparison of Bids**

30.1 The Employer will evaluate and compare only the Bids determined to be substantially responsive in accordance with Clause 28.

30.2 In evaluating the Bids, the Employer will determine for each Bid the evaluated bid price by adjusting the bid price as follows:

(a) making any correction for errors pursuant to Clause 28;

(b) applying any discounts offered by the Bidder for the award;

30.3 The Employer reserves the right to accept or reject any variation, deviation or alternative offer. Variation, deviation, alternative offers and other factors which are in excess of the requirements of the bidding documents or otherwise result in the accrual of unsolicited benefits to the Employer shall not be taken into account in bid evaluation.

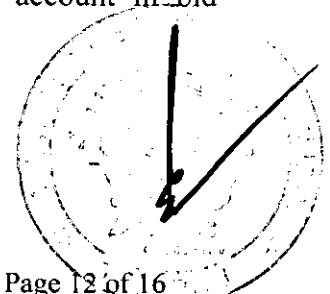



30.4 The estimated effect of the price adjustment provision of the Condition of Contract, applied over the period of execution of the Contract, shall not be taken into account in bid evaluation.

30.5 When the prices in the particular bid appear abnormally low (below 10% of the Analyzed Market Value) or the bid appears seriously unbalanced as determined, the Employer shall seek written explanations from the bidder submitting the low or seriously unbalanced bid and shall request the bidder an analysis of rates of the relevant items. Based on the bidder's written explanation, decision shall be taken to reject/accept the abnormally low or seriously unbalanced bids.

When the prices in the particular bid appear abnormally high (above 10% of the Analyzed Market Value), the Employer shall seek written explanations from the bidder submitting the high bid and shall request the bidder an analysis of rates of the relevant items. Based on the bidder's written explanation, decision shall be taken to reject/accept the abnormally high bids.

30.6 The Bid evaluations will be carried out **package-wise**.

### **31 Contacting the Employer**

31.1 Subject to Clause 26, no Bidder shall contact the Employer on any matter relating to its Bid, from the time of bid opening to the time of the Contract is awarded.

31.2 Any effort by a Bidder to influence the Employer in the Employer's decisions in respect of bid evaluation, bid comparison or Contract award will result in the rejection of the Bidder's Bid.

### **32 Employer's Right to Accept Any Bid and to reject any or All Bids**

32.1 The Employer reserves the right to accept or reject any Bid and to annul the bidding process and reject all Bids at any time prior to award of Contract, without thereby incurring any liability to the affected Bidder or Bidders or any obligation to inform the affected Bidder or Bidders of the grounds for the Employer's action.

### **F. Award of Contract**

#### **33 Award**

33.1 The Employer will determine to its satisfaction whether the Bidder selected as having the lowest evaluated responsive Bid is qualified to satisfactorily perform the Contract.

33.2 The determination will take into account the Bidder's financial and technical capabilities. It will be based upon an examination of the documentary evidence of the

Bidder's qualifications submitted by the Bidder, pursuant to Clause 14, as well as such other information as the Employer deems necessary and appropriate.

33.3 An affirmative determination will be a prerequisite for award of the Contract to the Bidder. A negative determination will result in rejection of the Bidder's Bid.

33.4 The Employer will award the contract to the lowest evaluated responsive bidder. In the event that the lowest evaluated bidder fails to conclude the contract, the employer may then call the successive lower responsive bidders for negotiations to conclude a contract with the approval of the Competent Authority.

In the event of a single Bidder being lowest in both the package, the employer, at the time of award, at its sole discretion shall award both the package or it may award only one package.

#### **34 Employer's Right to Vary Quantities at Time of Award**

34.1 The Employer reserves the right at the time of award of Contract to increase or decrease by up to twenty percent (20%) of the contract value, without any change in rate or other terms and conditions.

#### **35 Notification of Award**

35.1 Prior to the expiration of the period of bid validity prescribed by the Employer, the Employer will notify the successful Bidder in writing by registered letter or by fax that its Bid has been accepted. This letter (hereinafter and in the Conditions of Contract called the "**Letter of Acceptance**") shall name the sum which the Employer will pay the Contractor in consideration of the execution and completion of the Works by the Contractor as prescribed by the Contract (hereinafter and in the Conditions of Contract called the "**Contract Price**").

35.2 The notification of award will constitute the formation of a Contract, until the Contract has been affected pursuant to Clause 36.

35.3 Upon the furnishing by the successful Bidder of Performance Security or upon signing of the Contract Agreement, whichever is earlier, the Employer shall notify the other Bidders of the results of the bidding and shall publish a notification of award on the Employer's website.

#### **36 Signing of Contract**

36.1 At the time of notification of award, the Employer will send the successful Bidder the Contract form provided in the bidding documents, incorporating all agreements between the parties.

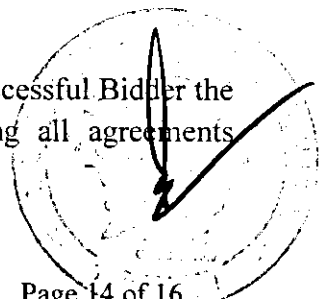

36.2 The successful Bidder shall be invited for Contract signing at the venue and date specified in the Letter of Acceptance.

**37 Performance Security**

37.1 Within ten (10) days of the receipt of the notification of award from the Employer, the successful Bidder shall furnish the Performance Security in an amount of ten percent (10%) of the Contract Price, in accordance with the Conditions of Contract, in the Performance Security Form provided in the bidding documents or another forms acceptable to the Employer.

37.2 Failure of the successful Bidder to comply with the requirements of Clause 36 or 37.1 above shall constitute sufficient grounds for the annulment of the award and forfeiture of the bid security.

**38 Corrupt or Fraudulent Practices**

38.1 The BPC requires that bidders observe the highest standard of ethics during execution of contracts. In pursuance of this policy, the BPC:

(a) defines the terms set forth below as follows:

(i) "corrupt practice" means behavior on the part of officials in the public or private sectors by which they improperly and unlawfully enrich themselves and/or those close to them, or induce others to do so, by misusing the position in which they are placed, and it includes the offering, giving, receiving, or soliciting of anything of value to influence the action of any such official in the procurement processes or in contract execution; and

(ii) "fraudulent practice" means a misrepresentation of facts in order to influence a procurement process or the execution of a Contract to the detriment of the BPC, and includes collusive practice among Bidders (prior to or after bid submission or in Contract execution) designed to establish by bid prices at artificial non-competitive levels and to deprive the BPC of the benefits of free and open competition;

(i) "coercive practice" means impairing or harming, or threatening to impair or harm, directly or indirectly, any party or the property of the party to influence improperly the actions of a party;

(ii) "Collusive practice" means an arrangement between two or more parties designed to achieve an improper purpose, including influencing improperly the actions of another party.

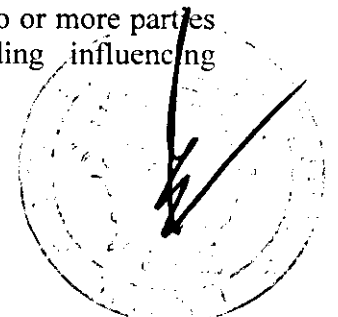

(v) “ Obstructive practice is

(i) deliberately destroying, falsifying, altering or concealing of evidence material to the investigation of making false statements to investigators in order to materially impede any investigation into allegations of corrupt, fraudulent, coercive or collusion practice; and/or threatening, harassing or intimidating any party to prevent it from disclosing its knowledge of matters relevant to the investigation or pursuing the investigation; or

(ii) acts intended to materially impede the exercise of the inspection and audit rights of the Employer or organization or person appointed by the Employer and/or relevant RGoB agency.

(b) will reject a proposal for award if it determines that the bidder recommended for award has, directly or through an agent, engaged in corrupt, fraudulent, collusive, or coercive practices in competing for the contract; and

Will declare a firm ineligible, either indefinitely or for a stated period of time, to be awarded a contract if at any time determines that the firm has engaged in corrupt or fraudulent practices in competing for, or in executing.

### 39 Labour

39.1 The Bidder shall commit that no child labour shall be engaged in any form.

*The deployment of labours for the project is confined to the Bhutanese labourers “By the Bhutanese, for the Bhutanese” and no non-national labours should be engaged for the works.*

### 40 Equal Pay

41.1 The men and women shall be paid equal for work of equal value.

### 41 Contractor Information Network (CiNet)

41.1 The performance of the Contractor shall be assessed as per the guidelines (average performance scoring form) contained in the CiNET available in CDB website.

41.2 The average performance scoring (APS) form is provided in the Section VII (Sample Forms) of the bidding document. The Bidder may initial all pages of Average Performance Scoring (APS) form agreeing to the applicability of APS form.

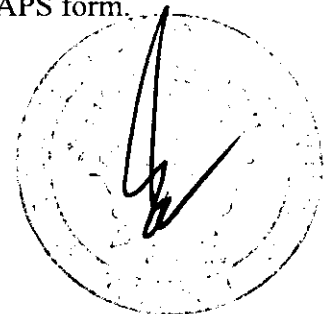

**SECTION III**  
**CONDITIONS OF CONTRACT**

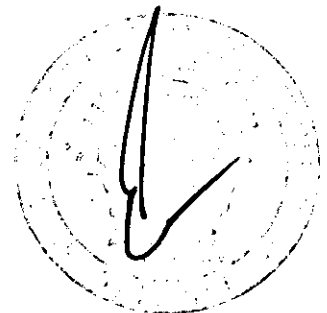

## TABLE OF CONTENTS

|  |          |
|--|----------|
| <b>SECTION III CONDITIONS OF CONTRACT.....</b>                 | <b>1</b> |
| <b>ARTICLE I GENERAL PROVISIONS.....</b>                       | <b>1</b> |
| A. Definitions.....  | 1        |
| B. Language and Enforcement of Contract.....                   | 2        |
| C. Amendments.....   | 2        |
| D. Settlement of Disputes.....                                 | 2        |
| <b>ARTICLE II EMPLOYER'S AND CONTRACTOR'S OBLIGATIONS.....</b> | <b>3</b> |
| <b>E. Employer's General Obligations.....</b>                  | <b>3</b> |
| 1. Payment of the Contract Price.....                          | 3        |
| 2. Measures for Commencement of Works.....                     | 3        |
| 3. Approvals, Authorizations.....                              | 3        |
| <b>F. Contractor's General Obligations.....</b>                | <b>3</b> |
| 4. Execution of the Works.....                                 | 3        |
| 5. Early Warning.....  | 4        |
| 6. Performance Security.....                                   | 4        |
| 7. Compliance with Laws, Rules and Regulations.....            | 4        |
| 8. Representation against Material Favours.....                | 4        |
| 9. Taxation.....   | 5        |
| <b>ARTICLE III CONDITIONS FOR EXECUTION OF THE WORKS.....</b>  | <b>5</b> |
| 10. Commencement Date.....                                     | 5        |
| 11. Time for Completion.....                                   | 5        |
| 12. Extension of Time for Completion.....                      | 5        |
| 13. Sub-contracting of the Work.....                           | 6        |
| 14. Work Program.....  | 6        |
| 15. Transportation of Materials.....                           | 6        |
| 16. Insurance.....   | 6        |
| 17. Contractor's Superintendence.....                          | 7        |
| 18. Engineer at Liberty to Object.....                         | 7        |
| 19. Setting Out.....   | 8        |
| 20. Safety of Operations and Protection of Environment.....    | 8        |
| 21. Provision of Competent Personnel.....                      | 8        |
| 22. Compliance with Standards.....                             | 9        |
| 23. Responsibility to Rectify Loss or Damage.....              | 9        |
| 24. Examination of Work.....                                   | 9        |
| 25. Monitoring of Work Progress.....                           | 9        |
| 26. Variation Orders.....                                      | 10       |
| 27. Instructions for Variations.....                           | 11       |
| 28. Measurement of works.....                                  | 11       |
| 29. Guarantee of Works after Completion Date.....              | 11       |
| 30. Indemnity for Infringement of Property Rights.....         | 12       |
| 31. Storage of Plant and Materials.....                        | 12       |

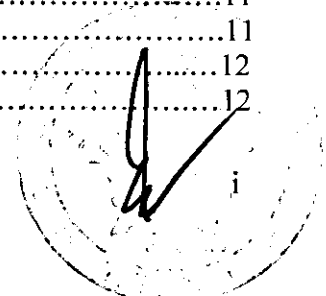

|  |           |
|--|-----------|
| 32. Facilities for Other Contractors.....              | 13        |
| 33. Unforeseen Obstacles.....                          | 13        |
| 34. Discoveries.....                                   | 13        |
| 35. Outbreak of Hostilities.....                       | 13        |
| 36. Suspension of work.....                            | 13        |
| 37. Liquidated Damages.....                            | 14        |
| 38. Termination of Contract by Employer.....           | 14        |
| 39. Termination of Contract by Contractor.....         | 15        |
| 40. Take Over of the Works by the Employer.....        | 15        |
| 41. Corrupt or Fraudulent Practices.....               | 15        |
| 42. Payment upon Termination.....                      | 16        |
| 43. Termination without Prejudice to Other Rights..... | 16        |
| <b>ARTICLE IV PAYMENT PROVISIONS.....</b>              | <b>16</b> |
| 44. Cash Flow Estimates.....                           | 16        |
| 45. Advance Payment.....                               | 17        |
| 46. Retention Money.....                               | 17        |
| 47. Additional Claims.....                             | 17        |
| 48. Price Adjustment.....                              | 17        |
| 49. Terms of Payments.....                             | 18        |
| <b>ARTICLE V COMPLETION OF THE WORKS.....</b>          | <b>18</b> |
| 50. Taking-Over Certificate.....                       | 18        |
| 51. Statement of Completion.....                       | 18        |
| 52. Contractor's Liability.....                        | 19        |
| 53. Release from Performance.....                      | 19        |



## SECTION III

### CONDITIONS OF CONTRACT

#### ARTICLE I GENERAL PROVISIONS

##### A. Definitions

The following words shall be construed in accordance with the meanings assigned to them, except when a different meaning is clearly intended:

(a) **Contract** - The signed Agreement entered into between the Employer and the Contractor and is deemed to include the following:

- 1) Invitation for Bids;
- 2) Instructions to Bidders;
- 3) Letter of Acceptance;
- 4) Conditions of Contract;
- 5) Technical Specifications and Drawings;
- 6) Price Schedules and Sample Bill of Quantities;
- 7) Bid Form;
- 8) Schedule of Supplementary Information; and
- 9) Such further documents as may be expressly incorporated in the Letter of Acceptance.

(b) **Employer** - The party who employs the Contractor to carry out the works or his duly authorized representative who can act on his behalf in supervising the implementation of the Contract.

(c) **Engineer** - Same as Employer.

(d) **Contractor** - The party (a person or corporate body) who is employed by the Employer to carry out the works.

(e) **Parties** - Refer to both Employer and Contractor.

(f) **Works** - What the Employer requires the Contractor to do under the Contract, which may involve the use of labour, process technology, equipment, materials and suppliers.

(g) **Plant** - Means machinery, apparatus, or instrument intended to form part of the works.

(h) **Specifications** - Means the specifications of the works included in the Contract and any modification or addition made or approved by the Employer.

(i) **Contract Price** - means the sum stated in the Letter of Acceptance.



- (j) **Priced Bill of Quantities** - The quantities of works to be done together with their corresponding unit prices. Includes also the kind of labour to be employed and their day/hour rates.
- (k) **Drawings** - Include drawings, calculation, samples, patterns, models, manuals and other technical information provided by the Employer to the Contractor under the Contract for the execution of the Works.
- (l) **Unit Rate** - The price for a given measurement of Works or materials or labour used in the Works.
- (m) **Sub-Contractor** - Is a person or corporate body who has a Contract with the Contractor to carry out a part of the Work under the Contract.
- (n) **Commencement Date** - The date indicated in the Notice to Proceed as the date for commencement of Work.
- (o) **Completion Date** - Is the date stated in the Taking-Over Certificate that the Works were substantially completed on this date in accordance with the Contract as per Clause No. 11 under Article III of condition of contract.
- (p) **Taking-Over Certificate** - Is the certificate issued by the Employer in accordance with the provisions of the Clause 50 under Article V of condition of contract, when the whole of the Works was completed.
- (q) **Variation Order** - An order issued by the Employer which involves changing any aspect of the Works.
- (r) **Defect** - Any part of the Works not executed and completed in accordance with the provisions of the Contract.
- (s) **Site** - Means the places provided by the Employer where the Works are to be executed and any other places as may be specifically designated in the Contract as forming part of the site.

## **B. Language and Enforcement of Contract**

The Contract is executed in English language. Enforcement of the Contract will be in accordance with Bhutan laws and any dispute not settled by arbitration shall be brought to a Bhutan court having jurisdiction thereof.

## **C. Amendments**

The Contract shall be amended only by written agreement between the Parties, except in such cases where the Employer may, under the provisions of the Contract, issue written instructions which shall be accepted by the Contractor

## **D. Settlement of Disputes**

Disputes arising from the implementation of the provisions of the contract shall be settled first by negotiations between the Parties in order to arrive at an amicable

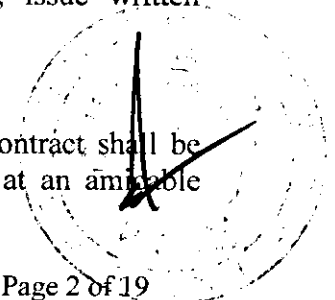

settlement. If negotiations fail, the matter will be settled by arbitration, whereby each of the parties will be entitled to appoint one arbitrator, and a third one to be appointed by mutual agreement to the parties. If either the Employer or Contractor fails to appoint a representative or if both of them cannot agree on the appointment of a third member within 30 days from the date of agreement to refer the matter for arbitration, then the case will be referred to the concerned Dzongkhag Court for adjudication.

## **ARTICLE II            EMPLOYER'S AND CONTRACTOR'S OBLIGATIONS**

### **E.     Employer's General Obligations**

#### **1.     Payment of the Contract Price**

The Employer shall pay the Contractor the Contract Price in Bhutanese Ngultrum as stipulated in the Contract. Payment(s) shall be made in accordance with the terms of payment and it is the Employer's obligation to ensure that funds are released on time and are made available as needed. The Employer must also ensure that issuance of certifications, authorizations, or pre-audit procedures are not unnecessarily delayed and that no undue inconvenience is suffered by the Contractor in obtaining payments.

#### **2.     Measures for Commencement of Works**

The Employer shall take all the steps necessary to enable the Contractor to commence work in accordance with the commencement date. These include giving the Contractor possession of the site of work and access thereto, acquisition of right-of-way if needed, provision of data on hydrological and sub-surface conditions, drawings and specifications, supply of equipment, materials or supplies if to be provided by the Employer, and appointment of the Employer's representative who will act as the Engineer on behalf of the Employer.

#### **3.     Approvals, Authorizations**

The Employer shall not unnecessarily withhold or delay giving any approval, authorization, instructions or notices as may be required by him under the provisions of the Contract. Any issue, problem, or matter submitted to him for consideration or decision must be addressed promptly and decisively.

### **F.     Contractor's General Obligations**

#### **4.     Execution of the Works**

The Contractor shall execute and complete the Works and remedy any defects therein to the satisfaction of the Employer in accordance with the provisions of the Contract. He shall provide all the technical expertise, labour, materials, machinery and equipment, plant and temporary facilities necessary for the execution and completion of the Works in accordance with the drawings, specifications, and instructions provided by the Employer under the terms of the Contract.

The Contractor shall, with due care and diligence, design (to the extent provided for by the Contract), execute and complete the Works and remedy any defects therein in

accordance with the provisions of the Contract. The Contractor shall provide all superintendence, labour, materials, Plant, Contractor's Equipments and all other things, whether of a temporary or permanent nature, required in and for such design, execution, completion and remedying of any defects, so far as the necessity for providing the same is specified in or is reasonably to be inferred from the Contract.

The Contractor shall give prompt notice to the Engineer, with a copy to the Employer, of any error, omission, fault or other defect in the design of or executing the work.

**5. Early Warning**

The Contractor shall warn the Employer at the earliest opportunity of specific likely future events or circumstances which may adversely affect the quality of the works, increase the Contract Price or delay the Intended Completion Date. The Employer may require the Contractor to provide an estimate of the expected effect of the future event or circumstance on the Contract Price and Intended Completion Date. The estimate shall be provided by the Contractor as soon as reasonably possible.

The Contractor shall cooperate with the Employer in making and considering proposals for how the effect of such an event or circumstance can be avoided or reduced by anyone involved in the Works and in carrying out any resulting instruction of the Employer.

**6. Performance Security**

On issuance of the Letter of Acceptance, the Contractor shall submit a performance security in favour of the Employer in the amount equivalent to **Ten percent (10%) of the Contract Price** to guarantee the faithful compliance of the Contractor's obligations under the Contract at the time of signing of the Contract Agreement. The Contractor shall provide such security in the form of a Bank Guarantee or irrevocable letter of credit acceptable to the Employer, issued by a bank in Bhutan. **The performance security shall be valid until the date of issue of the Taking-Over Certificate.** The cost of complying with the requirements of this clause shall be borne by the Contractor.

**7. Compliance with Laws, Rules and Regulations**

The Contractor shall, in the execution of the works, comply with all existing applicable laws, rules and regulations, and shall obtain the necessary permits, pay the required fees and taxes, and indemnify the Employer against any claim or liability arising from the violation of any law, rule or regulation.

**8. Representation against Material Favours**

The Contractor declares that it has not given, nor promised to give; any money, gift or material favour or consideration to any government official, Employee or any other Bidder to secure the Contract and that contrary action shall be sufficient ground for revocation of cancellation of the Contract.

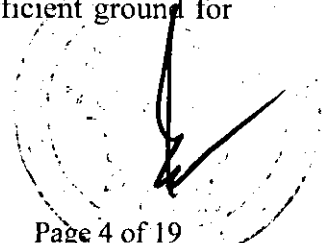
A handwritten signature in black ink is written over a circular stamp. The stamp contains some illegible text and a central emblem. The signature appears to be a stylized name.

**9. Taxation**

The prices bid by the Contractor shall include all customs duties, import duties, business taxes, income and other taxes that may be levied in accordance to the laws and regulations. Nothing in the Contract shall relieve the Contractor from his responsibility to pay any tax that may be levied by the Government.

**ARTICLE III CONDITIONS FOR EXECUTION OF THE WORKS**

**10. Commencement Date**

The Employer shall issue a Notice to Proceed, which will be the basis for commencement of work by the Contractor. The Contractor should start work not later than the date indicated in the Notice to Proceed. For justifiable reasons, the Employer and Contractor may subsequently agree on another commencement date.

**11. Time for Completion**

The Employer shall issue notice to proceed, which shall be the basis for commencement of work by the Contractor. The Contractor should start work not later than the date indicated in the notice to proceed. The Contractor shall begin the Works on the start date and shall perform and complete the Works in accordance with the program submitted by him, as updated with the approval of the Employer, by the intended completion date as below:

| Sl.No. | Dzongkhags            | Package Name | Duration (in month) |
|--------|-----------------------|--------------|---------------------|
| 1      | Bondeyma, Mongar      | A            | 9 Months            |
| 2      | Pemathang, S/Jongkhar | B            | 11 Months           |

**12. Extension of Time for Completion**

An extension of the time for completion may be allowed by the Employer for the following reasons:

- (a) additional work has to be done,
- (b) adverse climate conditions or other natural calamities have caused work stoppages,
- (c) delay or impediment on the part of the Employer, and
- (d) there are unusual circumstances that have occurred which are not directly attributable to the Contractor.
- (e) the delay caused by force majeure, including but not limited to war, riot, civil insurrection, strike or lockout by persons other than the contractor's personnel, fire, floods, epidemics, earthquakes, quarantine restrictions and

freight embargoes, such delay may be excused and the period of such delay may be added to the time of performance of obligation delayed.

The Contractor must give notice of any event causing a delay within twenty one (21) days of such occurrence and the Employer must within reasonable time decide on the extended date for completion. The Contractor shall extend the period of validity of the Performance Security accordingly.

**13. Sub-Contracting of the Work**

The Contractor shall not sub-contract the work or any part of the work under any circumstances. Sub-contracting of works shall lead to termination of the Contract and will lead to the forfeiture of performance security deposit.

**14. Work Program**

The Contractor shall prepare the Work Program for the execution of the works, if advisable, with the use of spread sheet or any other networks or equivalent. One original and two copies of such diagram must be provided to the Employer not later than twenty one (21) days after the commencement date. The work must cover all the activities for which the Contractor is responsible and must ensure that the resource required for the execution of each activity are or will be available and taken into account in setting activity duration.

**15. Transportation of Materials**

Materials required for the execution of the Contract are to be transported to the work sites for all packages by the Contractor at his own arrangements from the locations as indicated below. For details, the Bidder may contact the persons indicated under Clause 3.3 of Instructions to Bidders of the bidding documents.

| Sl.No. | Dzongkhags | Package Name | Store location                    |
|--------|------------|--------------|-----------------------------------|
| 1      | Mongar     | A            | RSD – P/ling,                     |
| 2      | S/Jongkhar | B            | RSD – Gelephu,<br>RSD-S/Jongkhar. |

The Contractor shall transport the materials to the work sites in such a manner that materials required at the earliest will be first transported.

**16. Insurance**

The Contractor shall obtain the following insurance coverage in such forms and amount as may be considered sufficient for the risk or liability insured against, and must be in force until the Taking-Over Certificate of the works is issued:

- (a) for the works (including plants and materials incorporated therein) and Contractor's equipment against loss or damage;

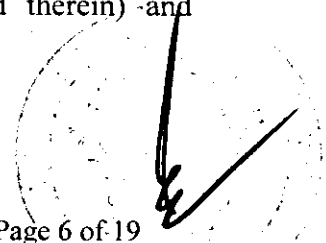

- (b) against liability for accidental death or injury of any person, or loss or damage to any property arising out of the performance under the Contract. The loss or damage of any material arising out of the performance under the Contract shall be made good;
- (c) against liability arising from accident suffered by the Contractor's workers while performing their work in accordance with Government rules and regulations; and
- (d) the Contractor shall avail full road accident insurance of goods during transportation from stores to work sites. The insurance policy should protect the goods during the vehicle accident viz. vehicle off road, head on collision, etc.

The Contractor shall assume full responsibility for the care and protection of the works, materials and plants from the commencement date to the date of acceptance of the whole of the Works, or of any section thereof incase of partial completion. Any loss or damage of the works occurring during this period shall be from the Contractor's account. However, if the loss or damage is caused by Force Majeure, including war, civil insurrection, fires, floods, epidemics and earthquakes, the cost of restitution therefore may be considered as an addition to the Contract Price to the extent that it is not recoverable from the proceeds of any insurance coverage.

**17. Contractor's Superintendence**

The Contractor shall provide all necessary superintendence during the execution of the Works and as long thereafter as the Engineer may consider necessary for the proper fulfilling of the Contractor's obligations under the Contract. The Contractor, or a competent authorized representative approved of by the Engineer, which approval may at any time be withdrawn, shall give his whole time to the superintendence of the Works. Such authorized representative shall receive, on behalf of the Contractor, instructions from the Engineer. If approval of the representative is withdrawn by the Engineer, the Contractor shall, as soon as is practicable, having regard to the requirement of replacing him as hereinafter mentioned, after receiving notice of such withdrawal, remove the representative from the Works and shall not hereafter employ him again on the Works in any capacity and shall replace him by another representative approved by the Engineer.

**18. Engineer at Liberty to Object**

The Engineer shall be at liberty to object to and require the Contractor to remove forthwith from the Works any person provided by the Contractor who, in the opinion of the Engineer, misconducts himself, or is incompetent or negligent in the proper performance of his duties, or whose presence on Site is otherwise considered by the Engineer to be undesirable, and such person shall not be again allowed upon the Works without the consent of the Engineer. Any person so removed from the Works shall be replaced as soon as possible.

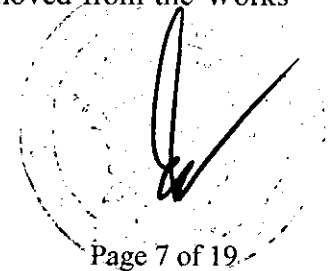

**19. Setting Out**

The Contractor shall be responsible for setting out the works and for ensuring the correctness of the positions, levels, dimensions and alignment of the works. The route alignment, identification of locations for the construction of substations and pole fixing will be conducted by the Contractor in the presence of the representative Engineer from the Employer. All the above settings have to be approved by the Site Engineer of the Employer prior to the commencement of works. All the measurements will be taken by the Site Engineer only for the works approved by the Employer. At any time during the execution of the works, the Contractor shall correct any error at his own expense when required to do so by the Employer. Boreholes, exploratory excavations or soil testing may be done if instructed by the Employer. In case, costs of boreholes or explanatory excavations or soil testing are not included in the Contract Price, the cost shall be borne by the Employer.

**20. Safety of Operations and Protection of Environment**

The Contractor shall assume full responsibility and comply with all applicable safety regulations for the adequacy and safety of site operations and methods of construction, and he shall adopt measures to prevent injuries to persons or damage to properties or utilities. He shall hold the Employer harmless for any liability for loss or damage resulting from his failures to take the necessary precautions. He shall avoid undue interference with private business, public travel, or with the work of other contractors. He shall take steps to protect the environment and to minimize noise, pollution or other undesirable effects from his method of operation.

The Contractor shall, throughout the execution and completion of the Works and the remedying of any defects therein:

- (a) have full regard for the safety of all persons entitled to be upon the Site and keep the Sites (so far as the same is under his control) in an orderly state appropriate to the avoidance of danger to such persons;
- (b) provide and maintain at his own cost all lights, guards, fencing, warning signs and watching, when and where necessary or required by the Engineer or by any duly constituted authority, for the protection of the works or for the safety and convenience of the public or other; and
- (c) take all reasonable steps to protect the environment on and off the Site and to avoid damage or nuisance to persons or to property of the public or other resulting from pollution, noise or other causes arising as a consequence of his method of operation.

**21. Provision of Competent Personnel**

The Contractor shall provide adequate qualified technical personnel to supervise the Works and such skilled and semi-skilled labour as necessary to complete the Works within the time specified. He shall, subject to the approval of the Employer, appoint a competent authorized representative who will act on his behalf in receiving instructions from the Employer and in supervising the execution of the works.

**22. Compliance with Standards**

The Contractor shall ensure that the quality of the materials, plants and workmanship meet all standards as specified in the Contract. Whenever a specific standard is mentioned in the specifications, it is intended only as a reference and equivalent or superior standards are equally acceptable subject to prior approval of the Employer. The execution procedure should be strictly adhered as specified in Section-IV, Technical Specification.

**23. Responsibility to Rectify Loss or Damage**

If any loss or damage happens to the Works, or any part thereof, materials or Plant for incorporation therein, during the period for which the Contractor is responsible for the care thereof, from any cause whatsoever, the Contractor shall, at his own cost, rectify such loss or damage so that the Permanent Works conform in every respect with the provisions of the Contract to the satisfaction of the Employer. The Contractor shall also be liable for any loss or damage to the Works occasioned by him in the course of any operations carried out by him for the purpose of complying with his obligations.

**24. Examination of Work**

The Employer shall have the right to conduct whatever tests or inspections it may consider necessary to determine whether or not the work is being executed in accordance with the provisions of the Contract. Such right may include testing of samples of materials used in the works, examination of the quality of the workmanship and conformity of the works to drawings and specifications.

The Contractor shall provide such facilities, apparatus and instruments, sample of materials, manpower and other forms of assistance that are needed in conducting the tests or inspections. Tests may be done in the workshops or at the site of operations and the date and time for carrying them out should be agreed upon between the Employer and the Contractor.

If the Employer determines, after inspections, that materials used or the work done are defective in any respects, he may reject the said materials or Works and demand that the Contractor rectifies the defects by replacing the materials or by re-executing the works. If the Contractor fails within a reasonable period of time to such action as instructed by the Employer, the Employer shall have the right to employ other persons to carry out the same and the cost shall be borne by the Contractor.

**25. Monitoring of Work Progress**

At such time as will be agreed upon between the Employer and the Contractor, a periodic review meeting of the progress made will be undertaken. Based on the actual progress achieved, if necessary, an up-date of the work program for the execution of the remaining works will be prepared by the Contractor taking into account the effect of variations and additional works to be undertaken. Failure to submit an updated work Program will entitle the Employer to withhold payment of the next amount due as progress payment.



If delay is being encountered in the execution of the Works as determined against the approved Work program, the Employer and the Contractor shall, after examining the causes of the delay, agree on appropriate measures to be taken in order to make up the delay and to avoid further work slippages.

The Employer's acceptance of any revised Work Program shall not relieve the Contractor of his obligations under the Contract.

## 26. Variation Orders

The Employer may, at any time during the progress of the Works, make variations in the form, quality or quantity of the works. Such variations may consist of the following:

- (a) Increase or decrease in the quantity of work to be done as indicated in the Contract;
- (b) Omission or insertion of any item of work;
- (c) Change in the level, lines, positions and dimensions of any part of the works;
- (d) Change in the character, quality, or kind of any work;
- (e) Additional work of any kind; and
- (f) Change in the sequence or timing of construction activities.

The Employer can order a variation by issuing a written instruction to the Contractor. A variation made shall not, in any way, vitiate or invalidate the Contract.

All variations, except under item (a) above, shall be valued at the rate and prices set out in the Contract ("Bill of Quantities"). If the Contract does not contain any rate(s) applicable to the variations, suitable rates or prices will be agreed upon between the Employer and the Contractor. In the event of disagreement between the parties, the Employer shall fix the rates as may consider fair and appropriate and shall notify the contractor.

The Contractor shall not make any such variation without an instruction of the Engineer.

For variations under item (a) increase or decrease in the quantities of work, variations shall be valued at the rates and prices set out in the Contract, if the variation in quantity is within the limit of (20%) for each item of work. If the final quantity of the work executed varies from the quantity in the Bill of Quantities of the Contract for that item by more than 20%, and the value of this variation exceeds one percent (1%) of the original Contract Prices stated in the Letter of Acceptance, the excess quantity over the limit shall be paid to the Contractor at a suitable rate or price agreed upon between the Employer and the Contractor. In the event of disagreement between the parties, the Employer shall fix the rates and prices as may be considered fair and

appropriate and shall notify the Contractor. If the value of this variation is less than one percent (1%) of the original Contract Price, the excess quantity shall be paid to the Contractor at the unit rate or price set out in the Contract. The value of all variations shall be taken into account in determining the final Contract Price.

*Note:*

*It may however, be noted that even in the event of any variation beyond this limit, payments shall be made strictly based on the actual volume of work executed and at the same rate or price set out in the Contract.*

**27. Instructions for Variations**

The Contractor shall not make any such variation without an instruction of the Engineer. Provided that no instruction shall be required for increase or decrease in the quantity of any work where such increase or decrease is not the result of an instruction given under this Clause, but is the result of the quantities exceeding or being less than those stated in the Bill of Quantity.

**28. Measurement of works**

The quantities set out in the Bill of Quantities should be considered as estimates and may not necessarily be the actual and correct quantities of work to be performed under the Contract.

The Contractor shall be responsible for the measurements of Works and the preparation of its bills. The measurement of works shall be carried out jointly by the Employer's representative and the Contractor. The Employer's Representative shall record the measurements in the measurement book in accordance with the Financial Manual. The record entered in the measurement book shall be signed by the Employer's representative and countersigned by the Contractor. The works shall be measured net except otherwise provided for in the specifications.

No part of the Works shall be covered up or put out of view without the approval of the Employer's representatives and the Contractor afford full opportunity for the Employer's representative to examine and measure any such part of the works which is about to be covered up or out of view. The Contractor shall give due notice examination and measurement. The Employer's representative shall, without unnecessary delay, arrange for examining and measuring such part of the works, unless he considers it unnecessary and advises the Contractor accordingly.

**29. Guarantee of Works after Completion Date**

The Contractor guarantees that the work performed, and the materials and equipment furnished shall be free from defects, that they comply with the prescribed specification and that they passed the required performance tests. This guarantee shall be **for a period of twelve (12) months** after the Completion of the whole Works known as defects liability period and within that period, the Contractor commits itself to repair or replace, promptly and without charge, any work, equipment and materials or part thereof which fail to meet the aforementioned guarantee.

Upon the issue of any Taking-Over Certificate, the Contractor shall clear away and remove from that part of the Site to which such taking-over Certificate relates all Contractor's Equipment, surplus material, rubbish and Temporary Works of every kind, and leave such part of the Site and Works clean and in a workmanlike condition to the satisfaction of the Engineer. Provided that the Contractor shall be entitled to retain on Site, until the end of the Defects Liability Period, such materials, Contractor's Equipment and Temporary Works as are required by him for the purpose of fulfilling his obligations during the Defects Liability Period.

**30. Indemnity for Infringement of Property Rights**

The Contractor shall indemnify the Employer for any claim, cost or liability on account of any infringement of any patent, trademark, trade name or any protected right in respect of equipment, materials or plants used in the Works except where such infringement results from compliance with the design or specifications provided by the Employer.

**31. Storage of Plant and Materials**

The Contractor shall provide adequate and safe facilities for storing Plant and materials that will be used in the execution of the works. They must be neatly piled and compactly stored in the places that provide clear access to the site and without causing any inconvenience or create any danger to the public.

Excavated materials, wreckage and waste products, shall be disposed off quickly so as not to cause unnecessary obstruction or create sanitation/environmental problems.

The loading of materials to their trucks will also be arranged by the Contractor and will comply with the instruction issued by the Stores Officer of the Employer.

If there is any balance materials left after the completion of the works which is supplied by the Employer under the Contract, the Contractor will hand over the same to the respective Electricity Services Division, as indicated by the Employer. The Contractor should meet all associated cost to this effect and the Employer shall not be responsible for any cost involved.

*If the Contractor fails to return the balance materials in full set of each item, the Contractor shall pay Employer's purchasing cost of the items plus 50% on the purchasing cost to the Employer. Final bills shall be released only after return of all balance materials.*

*Any excess materials returned by the Contractor will not be taken by the Employer and paid for. And, if the Contractor is not able to return the balance materials within fifteen (15) days after physical completion of the works successfully, the Employer shall collect the balance materials at the cost and risk of the Contractor before releasing the final payment to the Contractor. However, the balance materials collected by the Employer in incomplete set shall be construed as lost or unreturned whereby its associated cost shall be deducted from any money payable to the Contractor.*

**32. Facilities for Other Contractors**

The Contractor shall, upon the instructions of the Employer, provide other Contractors and workmen employed by the Employer, reasonable opportunity for carrying out the works and if required, to make available the use of roads, equipment and labour subject to additional compensation as may be determined by the Employer.

**33. Unforeseen Obstacles**

If during the execution of the works, the Contractor encounters physical obstructions or adverse geological or hydrological conditions on the site that could not have been reasonably foreseen, he shall give notice to the Employer, and both the Contractor and the Employer will determine:

- (a) to what extent and extension of time will be necessary, and
- (b) the amount of additional costs which have been incurred by reason of such obstructions or conditions and how, and by whom the cost will be born.

**34. Discoveries**

Anything of historical or other interest or of significant value discovered on the site shall be the property of the Employer. The Contractor shall notify the Employer of such discoveries and carry out in accordance with the instructions of the Employer for dealing with such discoveries.

**35. Outbreak of Hostilities**

If during the period when the Contract is in force, which may be before or during the execution of the works, there is an outbreak of hostilities between the armed opposite forces, which may impede or render impossible the commencement, continuance or completion of works, then the parties shall agree between themselves as to what steps will be taken under the circumstances, including a deferment or temporary suspension of the works or even termination of the Contract. However, the Contractor shall, until the decision has been reached, endeavour to start or complete the execution of the works to the best of his ability in close consultation with the Employer.

In case of termination by reason of outbreak of hostilities, the Employer shall pay the Contractor whatever amounts are due for Work already performed and for such other expenditures which the Contractor has incurred in accordance with the provisions of the Contract.

**36. Suspension of work**

The Employer may suspend the execution of the Works or any part thereof and the Contractor shall, during such suspension, protect the Works against loss or damage due to adverse external conditions. If the suspension is not due to default or breach of Contract on the part of the Contractor, an extension of time for the completion of works will be allowed, as may be determined by the Employer. The Employer and the

Contractor may also agree on the amount to be added to the Contract Price by reason of such suspension.

Should the suspension which is not caused by the default of the Contractor last for more than forty five (45) days, the Contractor may request thereafter permission to continue with the works giving his reasons thereof. If permission is not granted without justifiable reason within twenty one (21) days after permission has been requested, such denial may be treated as Employer's default and the Contractor shall be entitled to terminate his employment under the Contract.

The Contractor shall be entitled to suspend the execution of the works if the Employer fails or refuses to pay the Contractor any amount due under the Contract within sixty (60) days after the amount becomes due and payable, after prior presentation of notice for Payment. Should the Employer pay subsequently after such suspension or reduction of Work, the Contractor shall resume normal work as soon as is reasonably possible.

**37. Liquidated Damages**

If the Contractor fails to complete the whole of the works, or any part thereof within the time agreed upon for completion, the Employer shall have the right to collect from the Contractor liquidated damages equivalent to **0.1 percent of the Contract Price for every Day of delay**. However, the total amount of liquidated damages shall not exceed ten percent (10%) of **the Contract Price**. In case of the works being under different Dzongkhags and the contract terms providing for taking over of each of the Dzongkhag separately, the computation of Liquidated Damages would be based on the above for each Dzongkhag independently.

**38. Termination of Contract by Employer**

The Employer may terminate the Contract upon thirty (30) days notice to Contractor if the other party causes a fundamental breach of Contract. Fundamental breaches of Contract shall include, but not be limited to, the following:

- (a) Contractor has stopped working continuously for ten (10) days and in spite of repeated (three times) notice by Employer to start the work.
- (b) In the opinion of the Employer, in spite of repeated notice, Contractor was not able to deploy sufficient manpower at site to execute the Contract and may not be in position to complete the work as per schedule.
- (c) Continuance of the work has become impossible, or will work adversely against the Employer's interest.
- (d) The Contractor has become insolvent or financially incapable of completing the works or has assigned his assets for the benefit of his creditors.
- (e) The Contractor has violated certain important provisions to the Contract, such as Sub-Contracting of the works, failure to comply technical specifications,

poor workmanship, unreasonable delay etc., and has failed to take compensatory measures.

**39. Termination of Contract by Contractor**

The Contractor may terminate the Contract upon thirty (30) days notice to the Employer where;

- (a) The works have been suspended by the Employer for sixty (60) days and no permission to resume work has been granted; and
- (b) The Employer has failed to pay any substantial sums due to the Contractor under the terms of the Contract within the time specified for payment.

**40. Take Over of the Works by the Employer**

In case of termination under Clause 38 above, the Employer will take possession of the works, materials, tools & equipment which have been provided in connection with the Works, and may continue and complete the works by whatever manner or method it deems best including the employment of another Contractor. The cost of completing the same shall be deducted from whatever monies are due to the Contractor had the Contract not been terminated. If the amount due to the Contractor is less than the residual cost of completion, the Contractor shall pay the difference; if the residual cost is less, the Contractor shall have no claim to the excess, except for payment for rentals for the use of the Contractor's cost of protecting and securing the Works, and less all payments received by the Contractor up to the date of the Certificate.

**41. Corrupt or Fraudulent Practices:**

If the Employer determines that the Contractor has engaged in corrupt, fraudulent, collusive, coercive or obstructive practices in competing for or in executing the Contract, then the Employer may, after giving 14 days' notice to the Contractor terminate the Contractor's employment under the Contract and expel him from the site, and the Contractor shall stop the work immediately, make the site safe and secure, and leave the Site as soon as reasonably possible.

For the purpose of this Clause:

- (a) "Corrupt practice" is the offering, giving, receiving or soliciting, directly or indirectly, of anything of value to influence improperly the actions of another party;
- (b) "fraudulent practice" is an act or omission, including a misrepresentation, that knowingly or recklessly misleads, or attempts to mislead, a party to obtain a financial or other benefit to avoid an obligation;
- (c) "collusive practice" is an arrangement between two or more parties designed to achieve an improper purpose, including influencing improperly the actions of another party;

- (d) "coercive practice" is impairing or harming, or threatening to impair to harm, directly or indirectly, any party or the property of the party to influence improperly the actions of a party;
- (e) "Obstructive practice is
  - (i) deliberately destroying, falsifying, altering or concealing of evidence material to the investigation of making false statements to investigators in order to materially impede any investigation into allegations of corrupt, fraudulent, coercive or collusion practice; and/or threatening, harassing or intimidating any party to prevent it from disclosing its knowledge of matters relevant to the investigation or pursuing the investigation; or
  - (ii) acts intended to materially impede the exercise of the inspection and audit rights of the Employer or organization or person appointed by the Employer and/or relevant RGoB agency.

**42. Payment upon Termination**

If the Contract is terminated because of a fundamental breach of Contract by the Contractor and/or due to violation of any of the provisions under the Integrity Pact by the Contractor, the Employer shall issue a certificate for the value of work done less advance payments received up to the date of the issue of the certificate and less twenty percent (20%) of the value of work not completed. Additional Ligated Damages shall not apply. If the total amount due to the Employer exceeds any payment due to the Contractor, the difference shall be a debt payable by the Contractor to the Employer.

If the Contract is terminated for the Employer's convenience or because of a fundamental breach of Contract by the Employer, the Employer shall issue a certificate for the value of the work done, materials ordered, less advance payments received up to the date of the certificate.

**43. Termination without Prejudice to Other Rights**

The right of either the Employer or the Contractor to terminate the Contract in accordance with the foregoing provision is without prejudice to any actions, or remedies which either party may take under the provisions of the Contract.

**ARTICLE IV PAYMENT PROVISIONS**

**44. Cash Flow Estimates**

The Contractor shall submit a quarterly cash flow estimate indicating the amount of quarterly payments expected to be made under the Contract based on the approved Work Program.

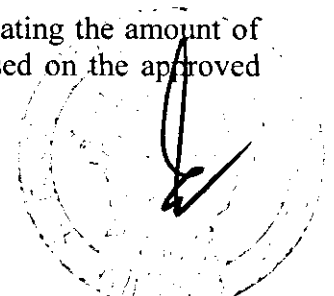

**45. Advance Payment**

The Contractor shall be eligible for advance payment of ten percent (10%) of the Contract Price excluding provisional sum and contingency, which can only be used to pay for equipment and other mobilization expenses required to start the works. The advance payment will be made only upon submission to the Employer of an unconditional bank guarantee in a form and by a bank acceptable to the Employer in amount equal to the advance payment. Such guarantee shall remain effective until the advance payment has been repaid fully.

The advance payment shall be repaid by the Contractor through percentage deduction from the interim progress payments and that the advance payment shall be fully repaid prior to the time when eighty percent (80%) of the Contract Price has been certified for interim progress payment. The amount of the bank guarantee may proportionately be reduced with every repayment made by the Contractor.

**46. Retention Money**

From each amount due for payment, the Employer will deduct ten percent (10%) thereof as Retention Money. Such deductions will be made until the completion of the Works and shall serve as a guarantee that any defects discovered during the Defects Liability Period will be corrected. Upon the expiration of the Defects Liability Period, the remaining balance to the retention money will be returned to the Contractor.

The Employer and the Contractor may agree that after the completion of the Works but during the warranty period, the Retention Money or part thereof will be returned to the Contractor and in lieu thereof, a bank guarantee may be put up by the Contractor.

**47. Additional Claims**

Should the Contractor have any additional claims for payment pursuant to any provision of the Contract, he shall advise the Employer about such claims, and submit to the Employer full details thereof including the basis of the claims. The Contractor shall permit the Employer to examine all records relevant to the claims.

Within thirty (30) days after receipt of the claims, the Employer shall establish the veracity and propriety of the claim and shall communicate to the Contractor his decision. The Employer may decide to pay the full amount claimed, or may opt to pay just part thereof, to the extent of what has been substantiated by the evidence submitted by the Contractor. In case of disagreement, an arbitrator(s) may be appointed by the parties to resolve any difference between them.

**48. Price Adjustment**

The rates and prices in the Bill of Quantities are fixed for the duration of the Contract. Hence, no price adjustment shall be applicable under the Contract.

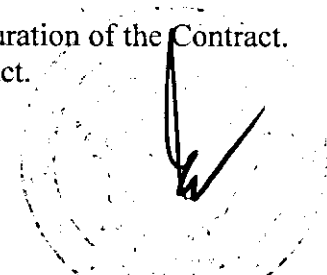



**49. Terms of Payments**

All payments under the Contract shall be made in local currency (Bhutanese Ngultrum). The Contractor shall submit monthly bills/invoices for completed works. The bills/invoices must be supported by joint measurement duly signed by the Engineer of the Employer. Based on these measurements, the Employer shall then review and verify the bills/invoices submitted by the Contractor and determine how much is actually payable to the Contractor after necessary deductions. The Employer may make any correction or modification in any previous payments which has been approved by him.

The final payment by the Employer to the Contractor in respect of the whole Works under the Contract shall be made as per Clause 51 under Article V.

Payment shall be made by the Employer within sixty (60) days from receipt of statement, unless delay is encountered in the submission of supporting documents if required by the Employer.

Where the Contract provides for partial take-over, the above payment terms apply for each of such partial works/packages independently.

**ARTICLE V COMPLETION OF THE WORKS**

**50. Taking-Over Certificate**

When whole of the works have been substantially completed and satisfactorily pass any tests on completion prescribed by the Contract, the Contractor may give a notice to this effect to the Employer, accompanied by a written undertaking to finish with due expedition any minor outstanding work during the Defects Liability Period. Such notice and undertaking shall be deemed to be a request by the Contractor for the Employer to issue a Taking-Over Certificate in respect of the work. *The Employer shall issue a Taking-Over Certificate, stating the date on which the works were completed in accordance with the Contract, give instructions in writing to the Contractor specifying all the work, including any defects in the Works affecting completion, and completion of return of all balance materials to the Employer, which is required to be done before the issue of such certificate.* The Contractor shall be entitled to receive such Taking-Over Certificate within 21 days of satisfactory completion of the works so specified and remedying any defects so notified.

**51. Statement of Completion**

After the issue of the Taking-Over Certificate in respect of the whole works and when the minor outstanding works have been completed including the final clean-up of the Site has been performed, the Contractor shall submit the Employer a Statement of Completion which shall show in detail:

- (a) The final value of the work done in accordance with the Contract, including variations.
- (b) Any further sums that are due to the Contractor and remain unpaid.

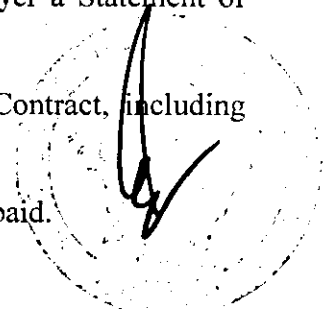

Upon receipt of such statement, the Employer shall conduct a final inspection of the Works, measure the works and within forty five (45) days from receipt of the statement of completion prepare a final estimate and present the same to the Contractor for his concurrence. This statement, if approved by both parties, is the final statement and the total amount of the final statement represent full and final settlement of all monies due to the Contractor arising out of or in respect of the Contract.

**52. Contractor's Liability**

Neither the final inspection nor the preparation of the final statement by the Employer, nor the issuance of the Taking-Over Certificate to the Contractor, nor the payment of the amount due, nor the possession by the Employer of the Work, shall operate as a waiver of the provision of the Contract, and the Contractor shall remain liable for a period of twelve (12) months from the date of completion, stated in the Taking-Over Certificate, for any defect or damage arising from any violation or lack of compliance with the covenants and conditions of the Contract.

Any work of reconstruction and correcting of defects must be done within thirty (30) days from receipt of advice of the existence of such defects by the Contractor. The cost of such works shall be for the account of the Contractor if the defect(s) were due to:

- (i) The use of materials, plant or workmanship not in accordance with the Contract;
- (ii) Fault in design for which the Contractor was responsible; and
- (iii) Failure on the part of the Contractor to comply with any obligation under the Contract.

Neither shall the Contractor be released of any unfulfilled obligations including, but not limited to, the payment of taxes due to him, and for unpaid claims for labour, materials and equipment used in the works.

**53. Release from Performance**

If the Contract is frustrated by the outbreak of war or by any other event entirely outside the control of either the Employer or the Contractor, the Employer shall certify that the Contract has been frustrated. The Contractor shall make the Site safe and stop work as quickly as possible after receiving this certificate and shall be paid for all work carried out before receiving it and for any work afterwards to which a commitment was made.

A circular stamp containing a handwritten signature. The signature is written in dark ink and appears to be a stylized name. The stamp is located in the bottom right corner of the page.

**SECTION IV**  
**CONSTRUCTION STANDARDS**  
**& TECHNICAL SPECIFICATIONS**  
**and DRAWINGS**



## CONTENTS

### CONSTRUCTION STANDARD & TECHNICAL SPECIFICATIONS

|   |           |
|---|-----------|
| <b>1.1 Overhead Lines.....</b>                                    | <b>1</b>  |
| 1.1.1 Choice of route.....  | 1         |
| 1.1.2 Approval of line routes.....                                | 1         |
| 1.1.3 Tree clearance.....   | 2         |
| <b>1.2 Overhead Line Construction.....</b>                        | <b>2</b>  |
| 1.2.1 Pit Marking and Digging Procedure.....                      | 2         |
| 1.2.2 Erection of supports.....                                   | 3         |
| 1.2.3 Erection of double pole structures for angle locations..... | 4         |
| 1.2.4 Special foundation in unstable soil.....                    | 4         |
| 1.2.5 Anchoring and providing guys for supports.....              | 4         |
| 1.2.6 Fixing of cross arms and insulators.....                    | 5         |
| 1.2.7 Erection of ACSR Conductor.....                             | 5         |
| 1.2.8 Mid – Span Jointing of Conductors.....                      | 6         |
| 1.2.9 Jumpering.....  | 6         |
| 1.2.10 Sagging and Tensioning of Conductors.....                  | 6         |
| 1.2.11 Conductor Sag and Tension.....                             | 8         |
| 1.2.12 Supports and Different Elevation.....                      | 11        |
| 1.2.13 Good conductor Stringing work practices.....               | 12        |
| 1.2.14 HV ABC Accessories.....                                    | 13        |
| 1.2.15 Low Voltage Aerial Bundle Conductor.....                   | 14        |
| <b>1.3 Special Crossings.....</b>                                 | <b>15</b> |
| <b>1.4 Guarding.....</b>  | <b>15</b> |
| <b>1.5 Pole Earthing .....</b>                                    | <b>16</b> |
| <b>1.6 Final Completion and Commissioning of MV Lines.....</b>    | <b>16</b> |
| <b>1.7 Installation of Distribution Transformer.....</b>          | <b>17</b> |
| 1.7.1 Pole Mounted Transformers.....                              | 17        |
| 1.7.2 Site Selection for pole mounted Transformers.....           | 17        |
| 1.7.3 Pad mounted Distribution Transformers.....                  | 17        |

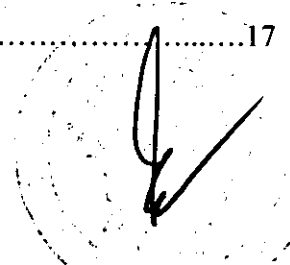

|  |           |
|--|-----------|
| <b>1.8 Substation Earthing.....</b>                          | <b>18</b> |
| <b>1.9 Transportation and Handling of Transformers.....</b>  | <b>18</b> |
| <b>1.10 Protection of Distribution Transformers.....</b>     | <b>19</b> |
| <b>1.11 General Requirement of Distribution Boards.....</b>  | <b>22</b> |
| <b>1.12 Connection of supply to consumer's premises.....</b> | <b>24</b> |
| 1.12.1 Consumer metering.....                                | 24        |
| 1.12.2 Direct Connected Metering.....                        | 25        |
| 1.12.3 CT Metering.....                                      | 25        |
| 1.12.4 High Voltage Metering.....                            | 25        |
| <b>1.13 Underground Cable Installation.....</b>              | <b>26</b> |
| 1.13.1 General.....  | 26        |
| 1.13.2 Outdoor cable Installation.....                       | 27        |
| 1.13.3 Bending Radii for cables.....                         | 27        |
| 1.13.4 Termination Clamping & Miscellaneous Details.....     | 28        |
| 1.13.5 Earthing of cables.....                               | 28        |
| <b>LIST OF DRAWINGS.....</b>                                 | <b>29</b> |
| <b>LIST OF ABBREVIATIONS.....</b>                            | <b>32</b> |
| <b>GLOSSARY OF TERMS.....</b>                                | <b>35</b> |
| <b>REFERENCES.....</b>                                       | <b>41</b> |



## SECTION IV

### CONSTRUCTION STANDARDS & TECHNICAL SPECIFICATIONS

#### 1.1 Overhead Lines

##### 1.1.1 Choice of Route

The route selected for an overhead line should be the one that will give the lowest cost over the life of the line. Route selection therefore involves consideration of a number of factors, including the cost of landowner compensation, the cost of transporting materials to the site, construction cost and the cost of ongoing maintenance requirements including vegetation control. As a general rule, line routes should be as short as practicable and should run as close to a road as possible since this facilitates access for both construction and maintenance. Consideration should also be given to the location of possible future line extensions, either to supply potential new loads or to service towns and villages that are currently un-electrified. Following parameters should be kept in mind:

- The shortest route practicable.
- As close as possible to the road for easy maintenance and approach during construction.
- Route in direction of possible future load.
- Angle points should be less.

Where possible, distribution line routes should avoid steep hills or valleys, swamps, lakes, thick forests, rivers or other locations where access is difficult or long spans are required. When building along a road, pole positions should not cause a traffic hazard or be in locations where there is a higher probability of vehicle impact.

The following should be avoided wherever possible:

- Areas likely to be used for future urban development;
- Routes incorporating sharp changes in line direction;
- Routes close to aerodromes;
- Religious monuments;
- Special trees of religious significance;
- School playgrounds;
- Cemeteries; and
- Buildings containing explosives.

Construction of lines over private land involves negotiation of a right of way and payment of compensation, and is to be avoided if a cost effective alternative route along public roads is available.

##### 1.1.2 Approval of Line Routes

Prior to the erection of lines along public roads, the authority responsible for the road should be contacted and approval obtained for the location of all poles, road crossings, tree cutting or

trimming, and guying locations. Where overhead distribution lines are to be constructed in urban areas, it will also be necessary to contact the local Town Planning Authority for approval. Where appropriate, approval should also be obtained from authorities such as the National Environment Commission, Department of Forestry, etc.

Once the line route is finalized, a detailed line survey should be undertaken and the pole locations finalized and marked. Poles should be located well clear of water and other areas of potential land subsidence. Poles for lines that cross agricultural fields should, wherever possible, be located at bunds. Procedure for Obtaining Environmental Clearance for the new project from National Environment Commission Secretariat (NECS) is given below:

- Fill in the project details in environmental clearance application guidelines for power transmission and distribution lines.
- Attached the following relevant statutory Approvals:
  1. Public Clearance from the affected parties if the tower/poles falls in Private Registered land.
  2. Gewog Approval from the concerned Gewog
  3. Forestry Clearance
  4. Dzongkhag Approval
  5. GPS Data / the google earth map of the project.
  6. Site Visit report from the Dzongkhag Environment committee (DEC).
- Submit the duly filled environmental clearance application with the aforementioned attachments to NECS for Environmental Clearance for the project through EDCD.

### 1.1.3 Tree Clearances

The width of line route to be cleared of trees will depend upon the voltage and the importance of the line concerned. While no rigid limits are provided, the following clearances should be adhered to, as far as possible.

**Table 86: Tree Clearance Distances**

| Voltage                      | Comment   |
|------------------------------|---|
| Low voltage ABC              | Left to the discretion of the supervisor. Aerial bundled low voltage conductor is insulated so contact with vegetation should not cause a fault. However the route should be cleared so the risk of tress falling on the line is minimized. |
| 11 kV lines (Bare Conductor) | The route should be cleared of all growth within 4.5 m of the centre line and, in addition, of trees that could fall and contact the line.  |
| 33 kV lines (Bare conductor) | The route should be cleared of all growth within 6 m of the centre line and in addition, of trees that could fall and contact the line.   |
| AAAC Covered Conductor       | The route should be cleared of all growth within 4.5 m of the centre line and, in addition, of trees that could fall and contact the line.  |

## 1.2 Overhead Line Construction

The construction of overhead lines may be divided as follows:

### 1.2.1 Pit Marking and Digging Procedure

After surveying, the pole location should be marked with peg. The pits should not be too large than necessary, as otherwise, after erection of the pole and filling there remains a possibility of tilting of pole. For Steel Tubular poles, the depth of the foundation shall be 1400 mm for 7.5 m pole and 1800 mm for 10 m pole, while the size of the foundation pit will be 600x800mm with longer axis in the direction of the line.

For Telescopic pole, the depth of the foundation shall be 1966 mm for 11.2 metre pole and 2100 mm for 12 m pole, while the size of the foundation pit shall be 800x1000 mm.

### 1.2.2 Erection of Supports

Steel poles that are not hot dip galvanized should be delivered to site with the exterior of the pole pre-painted with bituminous paint from the base of the pole up to ground level and rest with aluminum paint before the pole is installed.

Before the pole is put into the pit, pole cap and suitable base plate shall be fixed at the pole base to increase the surface contact between the pole and the soil. Once the pole is erected inside the pit, wooden deadmen may be utilized to facilitate lifting of the pole. Once lifted into the pit, the pole should be kept in a vertical position with the help of ropes, using them as a temporary anchor. It should be ensured that, at the time of erection, four men are at the ropes and the supervisor should be at a distance for guiding correct position so that in the event of breaking of rope, if pole falls, it will not result into an accident.

As the poles are being erected, say from an anchor point to the next angle point, the alignment of the poles is to be visually checked and set right. The verticality of the poles shall be checked with a spirit level in both transverse and longitudinal directions. In case of LV lines, the holes for fixing hook brackets should also to be checked to ensure they are facing the proper direction.

Once the verticality and alignment are satisfactory, the pit shall be backfilled and compacted to a distance of 450mm below ground level. A 450 x 450 mm (HT) & 350x350mm (LT) concrete foundation shall then be constructed around the pole and extending to 300 mm above the ground level as shown in the relevant drawings. The concrete shall be a mixture of cement, granite chips of 20/30 mm mesh and sand in the ratio of 1:2:4. The top of the foundation shall be tapered to allow water to run away from the pole.

Concrete foundations are not required for poles that are hot dip galvanized. In this case the foundation should be backfilled with excavated soil. The backfill should be progressively compacted as the foundation is filled. Do not simply refill the foundation and compact at the surface.

After the poles have been set and the excavated pit backfilled and compacted, the temporary anchors may be removed.



### **1.2.3 Erection of Double Pole Structures for Angle Locations**

On medium voltage lines, where the angle of deviation is more than 10 degrees, a double pole structure shall generally be erected. The pits are to be excavated along the bisection of the angle of deviation. If the angle of deviation is more than 60 degree, a four pole structure is to be used as shown in drawing no. BPC-DDCS-2015-61.

After erection of the poles the pits will need to be temporarily backfilled so the poles can be climbed and the horizontal bracing fitted. The structure should then be set for verticality and alignment and the supports held in position with the help of temporary rope guys.

The temporary backfilling should be removed and permanent foundations constructed by backfilling, compacting and, if necessary, concreting each pit as described in section 5.2.2. Concrete foundations are not required if the poles are hot dipped galvanized.

Guys along the bisection of the angle of deviation, as required by the conductor size and angle of deviation, are to be provided. These shall be constructed in accordance with section 5.2.5.

### **1.2.4 Special Foundation in Unstable Soil**

Special care has to be taken where foundation in unstable soil is encountered.

In such locations, mass concrete foundations, extending the full length (below the ground) of the pole, are to be adopted to avoid collapse of foundation in the unstable soil. The concrete is to be a mixture of cement, granite chips of 20/30 mesh and sand in the ration of 1:2:4.

### **1.2.5 Anchoring and Providing Guys for Supports**

One or more guys shall be provided for all supports where there is an unbalanced force on the support that may result in tilting/ uprooting or breaking of the support. Normally, these guys are provided at the following locations:

- Angles;
- Dead end locations;
- Tee-off points; and
- Steep gradient locations to avoid uplift on the poles.

Guy wires shall be angled at 45° from the vertical for 33 kV and 11 kV lines and 30° from the vertical for low voltage lines. Single guys shall be provided for single poles with line deviations from 5° to 10° and also for double poles with line deviations not exceeding 30°. Where the angle of deviation exceeds 30° two guys along the resultant angle of line deviation or one guy in each direction of the line shall be provided. When two or more stays are fixed to the same support, each stay should be attached separately to the pole.

The installation of guy will involve the following works:

- Excavation of pit and fixing guy rod;
- Backfilling and compacting the guy foundation;
- Fastening guy wire to the support; and

- Tightening guy wire and fastening to the anchor.

After completion of installation work the foundation shall be allowed to consolidate for at least 7 days before installation of the guy wire. When installing the guy wire, the turnbuckle shall be mounted at the pole end of the stay and guy wire so fixed that the turn buckle is half way in the working position; thus giving the maximum movement for tightening or loosening. No guy insulator shall be located less than 3 m from the ground. While binding the stay, pole should not be tilted. Thimble is necessary for stay binding. Where sufficient space is not available, the arrangement such as bow guy and stud pole support as shown in drawing no. BPC-DDCS-2015 60 may be adopted.

### **1.2.6 Fixing of Cross Arms and Insulators**

The practice of fixing the cross arm and top hamper before the pole erection is acceptable. If the cross arm is mounted after the support is erected, all the materials or tools required should be lifted or lowered by means of the hand line.

In such case, lineman should climb the pole with necessary tools. The cross arm is then tied to a hand line and pulled up by the ground man through a pulley till the cross arm reaches the line man. The ground man should station himself on one side, so that if any material drops from the top of the pole, it may not strike him. All the materials should be lifted or lowered through the hand line, and should not be dropped. Horizontal cross arms and pole top brackets shall be fitted as shown in the relevant drawings.

Line conductors are electrically insulated from each other as well as from pole by insulators. There are two types of porcelain insulators.

- The pin type insulators are generally used for straight stretch of line. The insulator and its pin should be mechanically strong enough to withstand the resultant force due to combined effect of wind pressure and weight of the conductor in the span.
- The strain insulators are used at terminal locations or dead end locations where the angle of deviation of the line is more than  $10^\circ$ .

In general the tie wire should be the same kind of wire as the line wire i.e. aluminium tie wire should be used with aluminium line conductor. The tie should always be made of soft annealed wire so that it may not be brittle and injure the line conductor. A tie wire should never be used for second time. The length of the wire will vary from 1m for 11 kV insulators to 3 m for 33 kV insulators.

### **1.2.7 Erection of ACSR Conductor**

During running out, the conductor drum should be securely supported on drum jacks with an axle, so that the conductor is pulled from the top of the drum. The drum jacks should be on a firm foundation and the axle of the drum jack should be levelled horizontally. Care must be taken to ensure that the conductors are not damaged by contact with the ground or pole hardware

during running out and that kinking, twisting or abrading the conductor is avoided. The conductor should not be trampled on, run over by vehicles or dragged over the ground.

Extreme care must be taken to avoid contact with the conductors of any other live line in the vicinity when running out or stringing conductors, and if necessary neighboring lines should be de-energized during the stringing operation.

Stays shall be installed and kept in position before conductors are strung to avoid over straining of poles. Stringing pulleys shall be used while stringing conductors.

### **1.2.8 Mid-Span Jointing of Conductors**

Mid-span jointing of conductors shall use compression joints correctly sized for the conductor and made with a proprietary compression tool using correctly sized dies. Before jointing, the conductor ends should be properly cleaned. In case of copper, clean by sand paper and for aluminium conductor, first apply jointing compound and then brush so as to remove the aluminium oxide. Mid span joints shall be avoided in the long spans such as river crossing, valley, etc.

### **1.2.9 Jumpering**

The jumper should always be connected through P.G. clamps. Care should be taken that mid span joint will not be less than 40 ft. from pole. Every joint should be done carefully. Where conductor strands are cut, repair sleeve is used. Conductor joint strength should be 95 % that of conductor, and resistance should be that of main conductor.

### **1.2.10 Sagging and Tensioning of Conductors**

After completion of conductor stringing and making any mid-span joints, conductor tensioning operations can commence. The conductors are first attached to the insulator string assembly at the non-tensioning end of the section, using preformed dead-ends. Further, before tensioning commences, temporary guys should be provided as necessary for the anchoring supports at each end of the line section to be tensioned to avoid over-stressing the strain poles due to unbalanced loads.

The centre conductor should be tensioned first followed by the outer two conductors. At the tensioning end, the conductor being tensioned is pulled manually up to a certain point and then a come-along clamp is fixed to it. The grip to the come-along clamp is attached to a double sheave pulley block or a pull-tight machine and the conductor is gradually tensioned.

The conductor should then be sagged in accordance with the sag-temperature chart for the particular conductor and span. The correct sag should be measured in the middle span of the section.

The stretch of the conductor has to be taken out before sagging in order to avoid the gradual increase in sag, due to the setting down of the individual wires. There are two ways of accomplishing this:

- **Prestressing**

Using the prestressing method, the conductor is pulled unto a tension considerably above the correct figure, but never exceeding 50% of breaking load for a period of about twenty minutes. As this method requires more time and involves the use of stronger tackle to secure the higher tension, it is not commonly used.

- **Over tensioning**

The over tensioning method consists of pulling up the conductor to a tension of 5%-8% above the theoretical tension for the prevailing temperature and fixing the conductor at that tension with correspondingly reduced sag. Over time, the conductor will settle down to the correct sag and tension.

Conductors can be sagged correctly only when the tension is the same in each span throughout the entire length of the section. Use of snatch blocks during sagging reduces the friction and chances of inequality of tension in various spans.

Measurement of conductor sag can be accomplished by several different methods but most commonly used method is 'sighting'. Targets are placed on the supports below the cross arms. The targets may be light strips of wood, which are clamped to the pole at each end of the sagging span at a distance below the conductor when the conductor is placed in snatch blocks that is equal to the required sag. A lineman sights the sag from the next pole and the tension of the conductor is reduced or increased, until the lowest part of the conductor in the span coincides with the lineman's line of sight.

When sagging is completed, the preformed dead end should be fixed to the tension end. The dead-end and socket thimble can be fitted to the conductor without releasing the tension. A mark is made on the conductor at a distance from the cross arms equal to the length of the complete strain insulator to indicate where the dead-end should be installed.

After the dead-end has been installed and the insulator string attached to the top hamper or cross arm, the conductor is pulled in sufficiently using the come-along clamp, to allow the insulator assembly to be fitted to the socket thimble. After the conductor is attached, the conductor tension may be released gradually. If the tension is released with a jerk, an abnormal stress may be transferred to conductor and support, which may result in the failure of the cross arms, stay or pole.

After the stringing is completed, all poles, cross-arms, insulators, fittings, etc. should be checked to ensure that there have been no deformities, etc.

The conductor is then placed on the pin insulator on each pole ready for tying and to remove the snatch blocks. On straight line poles the conductor should be tied to the top groove of the insulator and on angle poles the conductor should be tied to the side groove. The conductor is then fastened to the insulator using aluminium helities or binding wire conforming to IS 12048.

In fastening the conductor to pin insulators, the following points should be observed:

- The correct size of binding wire, which can be readily handled, and with adequate strength should be used.
- The length of tie wire should be sufficiently long for making the complete tie including and end allowance for gripping each end.
- A good tie should provide a secure binding between the line conductor and insulator, and should reinforce the conductor on either side of the insulator.
- The use of cutting pliers for binding the tie wire should be avoided.
- A helitie or binding wire that has been used previously should not be reused.
- Before tying the conductor to the insulator, it shall be ensured that only the portion of helities wrapped with chloroprene pad (where applicable) touches the insulator.

At section poles correctly sized parallel groove (PG) clamps must be used to connect the two conductor tails.

### 1.2.11 Conductor Sag and Tension

The following sag-span tables are provided for the guidance of field staff when stringing conductors.

**Table 87: Sag-Span Chart – 33 kV, WOLF**

**Conductor** : WOLF  
**Voltage** : 33 kV  
**Design Tension** : 3.42 kN at 15°C, no wind (approx 5% MBL)

| Temp            | 10°C           | 15°C | 25°C | 30°C | 75°C |
|-----------------|----------------|------|------|------|------|
| <b>Span (m)</b> | <b>Sag (m)</b> |      |      |      |      |
| 40              | 0.37           | 0.42 | 0.51 | 0.55 | 0.70 |
| 50              | 0.60           | 0.65 | 0.75 | 0.80 | 0.97 |
| 60              | 0.88           | 0.94 | 1.04 | 1.09 | 1.28 |
| 80              | 1.61           | 1.67 | 1.78 | 1.84 | 2.04 |
| 100             | 2.55           | 2.62 | 2.73 | 2.79 | 3.27 |
| 150             | 5.82           | 6    | 6    | 6.07 | 6.60 |

**Table 88: Sag-Span Chart – 33 kV, DOG**

**Conductor** : DOG  
**Voltage** : 33 kV  
**Design Tension** : 1.95 kN kg at 15°C, no wind (approx 5% of MBL)

| Temp     | 10°C    | 15°C | 25°C | 30°C | 75°C |
|----------|---------|------|------|------|------|
| Span (m) | Sag (m) |      |      |      |      |
| 40       | 0.34    | 0.40 | 0.50 | 0.55 | 0.88 |
| 50       | 0.56    | 0.62 | 0.73 | 0.79 | 1.17 |
| 60       | 0.83    | 0.89 | 1.01 | 1.07 | 1.49 |
| 80       | 1.52    | 1.59 | 1.72 | 1.78 | 2.26 |
| 100      | 2.38    | 2.45 | 2.59 | 2.65 | 3.19 |
| 150      | 5.44    | 5.52 | 5.66 | 5.73 | 6.33 |

**Table 89: Sag-Span Chart – 33 kV, RABBIT**

**Conductor** : RABBIT  
**Voltage** : 33 kV  
**Design Tension** : 1.04 kN at 15°C, no wind (approx 5% of MBL)

| Temp     | 10°C    | 15°C  | 25°C  | 30°C  | 50°C  |
|----------|---------|-------|-------|-------|-------|
| Span (m) | Sag (m) |       |       |       |       |
| 25       | 0.125   | 0.157 | 0.231 | 0.266 | 0.389 |
| 30       | 0.187   | 0.227 | 0.310 | 0.350 | 0.488 |
| 35       | 0.262   | 0.308 | 0.400 | 0.443 | 0.595 |
| 40       | 0.352   | 0.403 | 0.501 | 0.547 | 0.712 |
| 60       | 0.845   | 0.907 | 1.023 | 1.078 | 1.280 |

**Table 90: Sag-Span Chart –33 kV, AAAC Covered (111.3sq.mm)**

**Conductor** : AAAC Covered (111.3sq.mm)  
**Voltage** : 33 kV  
**Design Tension** : 1.22 kN at 15°C, no wind (approx 5% MBL)

| Temp     | 10°C    | 15°C | 25°C | 30°C | 75°C |
|----------|---------|------|------|------|------|
| Span (m) | Sag (m) |      |      |      |      |
| 40       | 1.27    | 1.29 | 1.35 | 1.37 | 1.58 |
| 50       | 1.99    | 2.02 | 2.07 | 2.10 | 2.32 |
| 60       | 2.88    | 2.91 | 2.96 | 2.99 | 3.21 |
| 70       | 3.93    | 3.96 | 4.01 | 4.04 | 4.27 |
| 80       | 5.15    | 5.17 | 5.23 | 5.25 | 5.48 |
| 90       | 6.52    | 6.55 | 6.6  | 6.63 | 6.86 |

**Table 91: Sag-Span Chart – 11 kV, DOG**

**Conductor** : DOG  
**Voltage** : 11 kV  
**Design Tension** : 5.71 kN kg at 15°C, no wind (approx 17% of MBL)

| Temp     | 10°C    | 15°C | 25°C | 30°C | 75°C |
|----------|---------|------|------|------|------|
| Span (m) | Sag (m) |      |      |      |      |
| 40       | 0.12    | 0.14 | 0.18 | 0.22 | 0.65 |
| 50       | 0.19    | 0.21 | 0.28 | 0.33 | 0.84 |

| Temp     | 10°C    | 15°C | 25°C | 30°C | 75°C |
|----------|---------|------|------|------|------|
| Span (m) | Sag (m) |      |      |      |      |
| 65       | 0.27    | 0.31 | 0.40 | 0.45 | 1.03 |
| 80       | 0.49    | 0.54 | 0.68 | 0.75 | 1.46 |
| 100      | 0.76    | 0.84 | 1.01 | 1.11 | 1.93 |
| 150      | 1.76    | 1.88 | 2.14 | 2.26 | 3.33 |
| 200      | 3.20    | 3.35 | 3.65 | 3.80 | 5.05 |
| 250      | 5.06    | 5.23 | 5.57 | 5.74 | 7.13 |
| 300      | 7.35    | 7.54 | 7.90 | 8.07 | 9.57 |

**Table 92: Sag-Span Chart – 11 kV, RABBIT**

Conductor : Bare ACSR RABBIT  
Voltage : 11 kV  
Design Tension : 3.02 kN kg at 15°C, no wind (approx 17% of MBL)

| Temp     | 10°C    | 15°C  | 25°C  | 30°C  | 50°C  |
|----------|---------|-------|-------|-------|-------|
| Span (m) | Sag (m) |       |       |       |       |
| 25       | 0.047   | 0.054 | 0.076 | 0.093 | 0.220 |
| 30       | 0.068   | 0.078 | 0.108 | 0.131 | 0.280 |
| 35       | 0.093   | 0.106 | 0.146 | 0.174 | 0.344 |
| 40       | 0.122   | 0.139 | 0.188 | 0.222 | 0.412 |
| 60       | 0.278   | 0.313 | 0.404 | 0.460 | 0.720 |

**Table 93: Sag-Span Chart –11 kV, AAAC Covered (111.3sq.mm)**

Conductor : AAAC Covered (111.3sq.mm)  
Voltage : 11 kV  
Design Tension : 4.13 kN at 15°C, no wind (approx 17% of MBL)

| Temp     | 10°C    | 15°C | 25°C | 30°C | 50°C |
|----------|---------|------|------|------|------|
| Span (m) | Sag (m) |      |      |      |      |
| 40       | 0.29    | 0.38 | 0.52 | 0.58 | 0.98 |
| 50       | 0.50    | 0.59 | 0.75 | 0.81 | 1.27 |
| 60       | 0.77    | 0.86 | 1.02 | 1.09 | 1.60 |
| 70       | 1.07    | 1.16 | 1.33 | 1.40 | 1.96 |
| 80       | 1.43    | 1.52 | 1.69 | 1.77 | 2.36 |
| 90       | 1.84    | 1.93 | 2.10 | 2.18 | 2.80 |
| 100      | 2.29    | 2.38 | 2.55 | 2.63 | 3.28 |
| 150      | 5.26    | 5.35 | 5.23 | 5.61 | 6.34 |

**Table 94: Sag-Span Chart –11 kV, AAAC Covered (49.98sq.mm)**

Conductor : AAAC Covered (49.98sq.mm)  
Voltage : 11 kV  
Design Tension : 2.01 kN at 15°C, no wind (approx 17% of MBL)

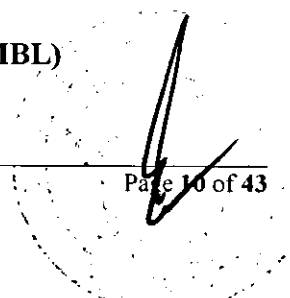

| Temp     | 10°C    | 15°C | 25°C | 30°C | 50°C |
|----------|---------|------|------|------|------|
| Span (m) | Sag (m) |      |      |      |      |
| 40       | 0.31    | 0.40 | 0.53 | 0.59 | 0.98 |
| 50       | 0.53    | 0.62 | 0.77 | 0.83 | 1.28 |
| 60       | 0.80    | 0.89 | 1.04 | 1.11 | 1.62 |
| 70       | 1.12    | 1.21 | 1.37 | 1.44 | 1.99 |
| 80       | 1.50    | 1.58 | 1.74 | 1.82 | 2.40 |
| 90       | 1.92    | 2.00 | 2.17 | 2.24 | 2.85 |
| 100      | 2.39    | 2.47 | 2.64 | 2.72 | 3.35 |
| 150      | 5.48    | 5.56 | 5.73 | 5.82 | 6.52 |

**Table 95: Sag-Span Chart – HV ABC (95sq.mm)**

Conductor : HV ABC (95sq.mm)  
Voltage : 11 kV  
Design Tension : 3.72 kN at 15°C, no wind (approx 5% of MBL)

| Temp     | 10°C    | 15°C | 25°C | 30°C | 50°C |
|----------|---------|------|------|------|------|
| Span (m) | Sag (m) |      |      |      |      |
| 20       | 0.53    | 0.54 | 0.55 | 0.56 | 0.54 |
| 30       | 1.21    | 1.21 | 1.23 | 1.24 | 1.21 |
| 40       | 2.15    | 2.16 | 2.17 | 2.18 | 2.16 |
| 50       | 3.33    | 3.37 | 3.46 | 3.50 | 3.37 |
| 60       | 4.84    | 4.85 | 4.87 | 4.88 | 4.85 |
| 70       | 6.60    | 6.60 | 6.62 | 6.63 | 6.60 |

**Table 96: Sag-Span Chart – HV ABC (50sq.mm)**

Conductor : HV ABC (50sq.mm)  
Voltage : 11 kV  
Design Tension : 2.01 kN at 15°C, no wind (approx 17% of MBL)

| Temp     | 10°C    | 15°C | 25°C | 30°C | 50°C |
|----------|---------|------|------|------|------|
| Span (m) | Sag (m) |      |      |      |      |
| 40       | 0.31    | 0.40 | 0.53 | 0.59 | 0.74 |
| 50       | 0.53    | 0.62 | 0.77 | 0.83 | 1.00 |
| 60       | 0.80    | 0.89 | 1.04 | 1.11 | 1.30 |
| 70       | 1.12    | 1.21 | 1.37 | 1.44 | 1.65 |
| 80       | 1.50    | 1.58 | 1.74 | 1.82 | 2.03 |
| 90       | 1.92    | 2.00 | 2.17 | 2.24 | 2.46 |
| 100      | 2.39    | 2.47 | 2.64 | 2.72 | 2.94 |
| 150      | 5.48    | 5.56 | 5.73 | 5.82 | 6.06 |

### 1.2.12 Supports at Different Elevation

Where the supports at each end of a span are at different elevations the following formula can be used for sagging the conductor.



$$d1 = d(1-h/4d)^2$$

where:  $d1$  = vertical distance between the conductor at the lower support and the lowest mid-span point.

$d$  = sag for a level span equal to the slope distance between the poles. The slope distance is the distance that would be measured by a tape stretched between the two poles. Once this is known the value of  $d$  can be taken from table 78 to table 88 above.

$h$  = difference in height between the conductor at each end of the span.

The above formula can be used to determine the value of  $d1$ . A sighting board can then be attached to the lower support pole and the conductor sagged be sighting horizontally through it. One way to do this would be to attach a second sighting board to the next pole. Check that the two sighting boards are level using a taut line and spirit level. The sag can then be sighted using the two sighting boards.

### 1.2.13 Good Conductor Stringing Work Practices

DO:

- Use proper equipment for handling aluminium conductors at all times.
- Use skids, or similar method for lowering reels or coils from transport to ground.
- Examine the reel before unreeling for presence of nails or any other object, which might damage the conductor.
- Rotate the reel or coil while unwinding the conductor.
- Unwind the conductor in the direction of the arrow on the side of the drum
- Grip all strands when pulling out the conductor.
- Control the unreeling speed with a suitable braking arrangement.
- Use wooden guards of suitable type to protect the conductor when pulling it over barbed wire fences, sharp rock edges or similar obstructions.
- Use long straight, parallel jaw grips with suitable liners when pulling the conductor in order to avoid nicking or kicking of the conductors.
- Use free-running sheaves or blocks with adequate grooves for drawing/paying conductors.
- Measure temperatures accurately with an accurate thermometer.
- Use proper sag charts.
- Mark conductors with crayons or adhesive tape or such other material which will not damage the strand.
- Make all splicing with the proper tools.

## DO NOT

- Do not handle conductors without proper tools at any stage.
- Do not pull conductors without first ensuring that there are no obstructions on the ground.
- Do not pull out a greater quantity of conductor than is required.
- Do not make jumper connections on dirty or weathered conductor. Instead, clean the conductor with sandpaper. Alternatively apply a chromite or graphite conducting oxideinhibiting grease to the point of connection and then clean the conductor with a wire brush.
- Do not handle aluminium conductor in a rough fashion but handle it with care it deserves.

At road crossings, a flagman should be in attendance to that traffic is not unduly interrupted. The running of conductor across roads should only be carried out in with the approval of the Authority responsible for the road.

Conductor drums should be transported to the tension point without injuring the conductor. If, it is necessary to roll the drum on the ground for a small distance, it should be slowly rolled in the direction of the arrow marked on the drum.

When running out conductor the drum should be so supported that it can be rotated freely. For this purpose, the drum should either be mounted on the cable drum supports or jacks or hung by means of chain pulley of suitable capacity, suspended from a tripod. If it is not possible to raise the conductor drum by any of the above methods, a trench of suitable depth slightly bigger than the conductor drum may be dug, so as to facilitate free rotation of the drum when it is suspended above the trench using a steel shaft. While running out the conductor, care should be taken to ensure that the conductor does not rub against any metallic fitting of the pole or on the uneven or rocky ground. Wooden trusses may be used for this purpose to support the conductor when running out.

Should the length the conductor be less than the length of the section, the conductors should be run out from both ends and joined where they meet with a mid-span full tension joint.

On no account, should any part of the conductor shall be left overnight at a height of less than 5 metres above the ground. The work should be so arranged that before the end of the day, the conductor is raised to a minimum height of 5 metres above the ground by rough sagging.

### 1.2.14 HV ABC Accessories

The following accessories are required for the installation of the HV aerial bundled cables:

- Pole bracket assembly
- Suspension assembly
- Strain clamp/dead end assembly.
- GI support hook
- Bundled restraint assembly

Each assembly shall be complete with all necessary devices suitable for attachment to round steel poles by stainless steel strap. All metal fitting shall be of good quality galvanized mild steel or cast aluminum alloy. Each of the suspension/angle/dead end assemblies shall be supplied with a 1.75m of stainless steel strap with two buckles. Bundled end protection shall be provided for protecting cable dead ends and shall comprise a set of heat shrinkable polymeric terminal caps for fitting on each conductor, together with protective black PVC sleeve of 500mm length. The following connectors are required for the connection of HV aerial bundled conductors:

- (a) Insulated tension jointing sleeve
- (b) XLPE cable termination push on type

The connections shall be insulated and suitable for use on live lines. The teeth of the contact plates shall penetrate the bundled conductor insulation to establish contact with ABC cable without the need to strip the bundled conductor insulation. The connector shall be suitable for copper or aluminum tee-off conductor. Insulated tension jointing sleeves shall be provided for the bundled conductors. These shall be of the compression type, but compression shall not damage or displace the sleeve insulation. The sleeve connectors shall be designed to have the full rated breaking strength of the aluminium or aluminium alloy cable on which they are fitted.

### 1.2.15 Low Voltage Aerial Bundled Cable

A sag-span chart for ABC conductor, assuming typical installation conditions is given in table below.

**Table 97: Sag-Span Chart for Low Voltage ABC**

| Conductor Size<br>Design Tension at 15°C<br>(kN) | 50mm <sup>2</sup> |      | 95mm <sup>2</sup> |      |
|--|-------------------|------|-------------------|------|
|  | 2.52              | 5.04 | 4.79              | 9.58 |
| Span (m)   | Sag (m)           |      |                   |      |
| 30   | 0.15              |      |                   |      |
| 40   | 0.26              |      |                   |      |
| 50   | 0.41              |      |                   |      |
| 60   | 0.59              |      |                   |      |
| 70   | 0.80              |      |                   |      |
| 80   | 1.04              |      |                   |      |
| 90   | 1.32              |      |                   |      |
| 100  | 1.63              |      |                   |      |
| 110  | 1.97              |      |                   |      |
| 120  | 2.35              |      |                   |      |
| 130  | 2.75              |      |                   |      |

BPC uses 7.5 m poles to support ABC conductors, and the maximum allowable span length on level ground is shown in table 90 below. The table assumes the cable is located 150 mm from the top of the pole, depth of burial is 1/6 of pole length and that minimum ground clearances are as shown in table 98.

**Table 98: Maximum Spans for Aerial Bundled Cable**

| Pole Length (m) | Maximum Span (m) |              |
|-----------------|------------------|--------------|
|                 | Across Street    | Elsewhere    |
| 7.5             | 50               | 80 (4 core)  |
|                 |                  | 100 (2 core) |

In installing aerial bundled cable the cable must be pulled from the top of the drum and should not be dragged along the ground. A suitable 'drum brake' mechanism should be used to prevent conductor overrun. Stringing pulleys compatible with bundled conductor shall be installed on every pole. During running out, the cable should be pulled out by hand or by using a nylon pulling grip designed for bundled cables. Insulated conductor grips designed to prevent damage to the insulation of the conductor shall be used for tensioning. Every care must be taken to avoid damage to the conductor insulation.

Dead-end (termination) fittings shall be fitted to the conductor after tensioning at each termination point. Intermediate fittings shall then be fitted at major angles and then at smaller angles. After all fittings are in place the sagging should be checked at two places and corrected if necessary. Insulation straps (cable ties) shall be used to tie the conductor at each supporting point.

**1.3 Special Crossings**

In case the lines cross-over the other lines or buildings, safe minimum clearance are to be maintained as mentioned in table 9. The other crossings could also include for:

- Telephone lines
- Lines of other voltages
- Roads, streets and rivers.

Double pole or 3 pole or 4 pole structure would be required to be specially designed, depending upon the span and conductor size for the river crossing. The foundation of the structures should be sound so that it may not get eroded or damaged due to rain water. 12 m steel tubular pole shall be used in such situation.

**1.4 Guarding**

Guarding is an arrangement provided for the lines by which live conductor, when accidently broken is prevented to come in contact with other electric lines, telephone lines, roads and persons or animals and carriages moving along the road, by providing a sort of cradle below the main electric line. The guarding is always earthed. In absence of guarding, conductor will fall on ground and as no protection is operated, conductor will remain charged. This will cause accidents. Hence the guarding is very essential.

Cradle guarding is adopted for lines with bare conductor at road crossing based on the risk imposed to pedestrian and vehicle plying below. Guarding shall be of 3 wire system. 1 wire on

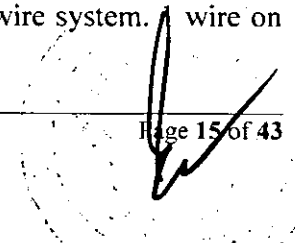

lower side and two on the upper side of the angle as shown in BPC-DDCS-2015-62. Requirement of guarding shall be as follows:

- Guarding is to be used for road crossing of power line with bare conductor only.
- G.I. wire of 8 W.S.G is used for guarding.
- The first lacing should be at a distance of 750 mm from the pole. Other lacing is tied at a distance of 3 meter from each other.
- The vertical distance between conductor and guarding in mid span should be 1220 mm.
- The clearance between line and guarding cross arm for 11 kV and 33 kV line should be 650 mm and 840 mm respectively.

### **1.5 Pole Earthing**

All 11 kV and 33 kV steel poles should be separately earthed. The earth pin is a 2.5 m galvanized steel rod, which must be driven into undisturbed ground clear of the pit excavation. It is not acceptable to insert the earth rod in the pit excavation as the backfill used often does not provide a good earth connection.

The earth pin is connected to the pole using galvanized iron flat of size 25x6mm. The flat is connected from the pole base to the spike rod using nuts and bolts. Details of spike earthing are shown in drawing no. BPC-DDCS-2015-48.

The earth resistance of the pole and earth pin connected together should be as low as possible and ideally should not exceed 10 ohms. Additional earth pins, spaced at least 1 metre apart, should be used in difficult locations, to reduce the resistance. Stake earthing is not required for LV poles since the lines are of covered conductor.

The earthing stake for pole earths is also used for earthing LV distribution pillars.

### **1.6 Final Completion and Commissioning of MV Lines**

Before a line is energized for the first time pre-commissioning installation work must be completed on each pole. This comprises:

- The painting of non-galvanized poles with aluminium paint with the bottom two meters above the ground and below the ground to be painted black;
- The attachment of anti-climbing device at a height of 3.5m to 4m from ground level to medium voltage pole to avoid unauthorized pole climbing. Fixing of danger notices to single/ double pole structure where required by BPC. The danger notices should be fixed about 2 meter above ground level and, where appropriate, should face the road or any track or other pedestrian walkway.
- Before commissioning a line into service, the line shall be visually checked over its full length to ensure that all structures are correctly installed, all pole earths are installed and connected, all conductors are correctly bound and terminated on all structures and all tools and other equipment have been removed.

The line shall be energized with all distribution substations isolated and unloaded on the low voltage side. Where the line is directly connected to a zone substation supply bus, rather than to an upstream line, the protective relay settings should be reduced. Once the line has been successfully energized, the correct protection relay settings should be applied and the distribution substations connected to the load one at a time.

## **1.7 Installation of Distribution Transformer**

As discussed in previous section, transformer capacity of 125 kVA and below shall be pole mounted.

### **1.7.1 Pole Mounted Transformers**

For installing pole-mounted transformers, as far as possible, subsidiary poles and street lighting poles should not be used as transformer poles. Special care should be taken to maintain proper climbing space and to avoid crowding of wire and equipment. Transformers should be installed only on poles strong enough to carry their weight. Transformer poles should be straight and, where necessary, guyed to prevent leaning or raking of the pole after the transformer is hung. Double cross-arms should be provided for each transformer installation. The climbing space (2400mm Pole Center-Center) should be carefully maintained so that it should not be necessary for a lineman to come close to the transformer tank in climbing up or down a pole. An anticlimbing device should be provided.

### **1.7.2 Site Selection for Pole mounted Transformers**

The location of pole mounted distribution transformer substations should ideally be:

- As close as possible to the center of the load, in order to reduce the voltage drop in the low voltage circuits;
- In a location that is clear of obstructions and is that provides satisfactory access for the incoming medium voltage overhead distribution line;
- Readily accessible for transport of the distribution transformer to site;
- Above a road rather than below it where this is practical; and
- In a location likely to provide a low resistance to earth.

### **1.7.3 Pad Mounted Distribution Transformers**

Since the transformers operate without moving parts, generally a simple foundation is satisfactory; provided it is firm, horizontal and dry. The transformer should not rock or bed down unevenly so as to tilt, as this may strain the connections. The base should be horizontal to keep the oil level correct. For outdoor transformers where rollers are not fitted, leveled concrete plinth with bearing plates of sufficient size and strength can be adopted. The plinth shall be above the maximum flood level of the site and of the correct size to accommodate the transformer in such a way so that no person may step on the plinth. Where rollers are fitted, suitable rails or tracks should be provided and when the transformer is in the final position, the wheels should be locked by locks or other means to prevent accidental movement of the transformer.

The foundation should be constructed of Plain concrete cement or reinforced, air entrained concrete having enough strength to hold the individual transformer load. The dimension of the plinth shall be designed based on approved transformer drawing however the height of the plinth shall be 1000 mm above the ground level. The equipment installed shall be enclosed by a chain link fence. The size of chain link fence shall be 10 mx10 m as shown in drawing no. BPCDDCS-2015-63.

### **1.8 Substation Earthing**

Particular care should be given to the construction of the earthing system as proper earthing of distribution transformer substations is necessary to ensure safe operation of the supply system. The earth pits should be located as shown in drawing no. BPC-DDCS-2015-64 and the earth connections to the substation structure are shown in drawing BPC-DDCS-2015-65.

BPC's standard earthing conductor for transformer substations is 25x6mm galvanised iron strap. Three electrodes are used forming an equilateral triangle with minimum distance of 6500 mm, so that adequate earth buffer is available. Each Electrode shall be a GI pipe of 4mm thick, 40mm outer dia and 2500mm long and buried vertically so as to leave about 4 inch pipe length above ground level to fix a 250x250mm G.I plate. The three earth electrodes should be connected together by an equipotential earthing ring embedded at least 100 mm below ground level. These are connected as follows:

- One earth electrode is connected to each lightning arrestor and the transformer tank. It is important that the earthing conductor is kept as short as possible.
- The second earth electrode is connected to the transformer LV neutral bushing, the transformer tank and the cross arms supporting the drop-out fuses.
- The third earth electrode is also connected to the transformer tank and LV neutral and also to the earth in the low voltage distribution cabinet.

There shall be minimum joints preferably no joints enroute to earth electrodes. Where Joints are unavoidable, they shall be brazed, riveted or welded and bolted (and painted with red lead and aluminum paints one after the other and finely coated with bitumen). The maximum permissible earth resistance as per the international standard is 5 ohms, however, due to difficulties to obtaining required value of 5 ohms, 25 ohms is allowable value in BPC. Modern earthing compounds are recommended instead of salt and charcoal to reduce the earth resistance of the substation in extreme situations.

### **1.9 Transportation and Handling of Transformers.**

Distribution transformers should be stored in such a way that 'first in and first out' becomes a normal procedure. Care must be taken to place the transformers in store in such a fashion that no damage occurs to tank, bushings, etc. due to movement of personnel and materials.

Transformers should be loaded and unloaded with care. Prior to loading a transformer for dispatch to site, the transformer condition (bushings, fittings, tank, oil level, etc.) should be checked. If any damage is noticed, the in-charge should be notified immediately, and transformer should be loaded only after the written approval of the person in charge.

Every transformer dispatched to site should be entered individually in store register. This register should have the following:

- (i) Sl. No.
- (ii) Date of receipt
- (iii) Transformer capacity (kVA)
- (iv) Manufacturer's name
- (v) Date of Dispatch to site
- (vi) Name of site

Transformers should be lifted using the lifting lugs provided on the transformer tank and the lifting arrangement should not cause unbalance of the transformer. Before lifting the complete transformer, it should be ensured that all cover bolts are tightened. The slings, lifting tackle, etc. to be used in hoisting of transformers should have adequate strength to handle the weight.

During transport of transformers, they should be rigidly secured to the transport vehicle and packing material put on either side of the base of the transformer to prevent skidding. A responsible official shall supervise the loading. Rollers, if provided, should be removed.

Care should be taken in transporting transformers to site to prevent the transformers moving when going up and down hills and around corners.

The transformer should be brought just adjacent to the double pole structure for hoisting it on the transformer platform. Lifting tackle should be used for hoisting transformer on the structure.

In case, it is not possible to bring the vehicle carrying transformer near the double pole structure, it should be unloaded at a nearest safe place and carried to the double pole structure manually with great care and under proper supervision or shifted on platforms fitted with rollers.

While hoisting transformers on the transformer platform, safety precautions by way of fixing additional clamps and bolts should be taken. Readymade slings to suit the capacity of transformer should be available.

### 1.10 Protection of Distribution Transformers

The pole mounted distribution substation arrangement has been standardized to the extent possible with the structure and the high voltage connections being identical for all transformer sizes. Dropout fuses are provided on H.V side of the transformer for isolating and protection. The size of fuse link used in these drop out fuses will vary with transformer rating. Acceptable fuse link sizes for BPC's existing transformer capacities are given in table 99 below: For transformers located at the remote end of rural feeders, where the short circuit levels are potentially low, fuse links at the lower end of the allowable range should be used.

**Table 99: Acceptable Transformer Medium Voltage Fuse Link Ratings**

| MV Rating (kV) | Phases | Capacity (kVA) | Rated Current (A) | Fuse Link (A) |
|----------------|--------|----------------|-------------------|---------------|
| 33             | 3      | 63             | 1.1               | 2 to 4        |



| MV Rating (kV) | Phases | Capacity (kVA) | Rated Current (A) | Fuse Link (A) |
|----------------|--------|----------------|-------------------|---------------|
| 33             | 3      | 125            | 2.2               | 4 to 7        |
| 33             | 3      | 250            | 4.4               | 9 to 16       |
| 33             | 3      | 500            | 8.7               | 16 to 32      |
| 33             | 1      | 10             | 0.3               | 1 to 2        |
| 33             | 1      | 16             | 0.5               | 1 to 2        |
| 33             | 1      | 25             | 0.8               | 2 to 3        |
| 11             | 3      | 16             | 0.8               | 2 to 3        |
| 11             | 3      | 24             | 1.3               | 2 to 4        |
| 11             | 3      | 63             | 3.3               | 7 to 9        |
| 11             | 3      | 125            | 6.6               | 16 to 25      |
| 11             | 3      | 250            | 13.1              | 32 to 40      |
| 11             | 3      | 500            | 26.2              | 50 to 100     |
| 11             | 3      | 1250           | 65.6              | 150 to 300    |
| 11             | 1      | 10             | 0.9               | 2 to 3        |
| 11             | 1      | 16             | 1.5               | 3 to 7        |

On the low voltage side of the transformer the supply cable is run into a 4-way feeder cubicle mounted on the transformer structure. The cubicle's incoming cable is terminated into a circuit breaker which can be used to offload the transformer. Three pole moulded case circuit breakers (MCCBs) shall be used for transformer sizes up to and including 315 kVA. Air circuit breakers may be used for larger transformers.

Circuit breakers shall comply with the requirements of IEC 60947-2 and shall be of the air break, quick make, quick break, trip free type, and fitted with electronic overcurrent, earth fault and short circuit protection. This protection shall not require an external power supply. The elements shall be adjustable so that adjustments are made simultaneously on all poles from a common adjustment control. The minimum interrupting current shall be 10 kA for transformers rated up to 250 kVA and 25 kA for larger transformers. When commissioning the transformer the MCCB overload shall be adjusted to be consistent with the full load transformer current as shown in table 99.

The size of the LV cable between the transformer and the feeder cubicle will depend on the size of the transformer, and is given in the following table 100. For non-standard intermediate size transformers the cable rating for the next size should be used. The table assumes that all cables up to 400 mm<sup>2</sup> are PVC insulated. The 630 mm<sup>2</sup> cable used on the 1,250 kVA transformer must be XLPE insulated in order to have the required rating.

**Table 100: Low voltage cable ratings used between transformer and DP**

| Phases | Transformer Rating (kVA) | Maximum LV Current (A) | LV Cable Size (mm2) |
|--------|--------------------------|------------------------|---------------------|
| 3      | 10                       | 14                     | 35                  |
| 3      | 16                       | 22                     | 35                  |
| 3      | 25                       | 35                     | 35                  |
| 3      | 63                       | 88                     | 70                  |
| 3      | 125                      | 174                    | 150                 |
| 3      | 250                      | 348                    | 300                 |
| 3      | 500                      | 696                    | 2x300               |
| 3      | 1250                     | 1740                   | 2x630 <sup>1</sup>  |
| 1      | 10                       | 42                     | 35                  |
| 1      | 16                       | 67                     | 35                  |
| 1      | 25                       | 104                    | 35                  |

*Note 1 Must be single core XLPE insulated cable.*

MCCBs may be used to protect outgoing distribution circuits in urban areas. As for incoming circuit breakers, the minimum interrupting current shall be 10 kA for transformers rated up to 250 kVA and 25 kA for larger transformers. Whereas the incoming MCCB is set in accordance with the transformer size, the setting of the outgoing MCCBs should be determined by the size of the cable being protected. The maximum MCCB setting if used for outgoing circuits is given in table 101. In order to obtain protection discrimination, outgoing MCCB current settings should be lower than the incomer, even if this is less than the rating of the outgoing cable.

**Table 101: Max. MCCB Ratings for Three Phase Low Voltage Aluminium Cable Circuits**

| Cable Size (mm2) | Maximum MCCB current setting <sup>1</sup> |
|------------------|---|
| 35               | 100                                       |
| 70               | 135                                       |
| 150              | 210                                       |
| 300              | 305                                       |
| 400              | 335                                       |

*Note 1: This is the same as the cable rating given in table 100.*

For low rating distribution substations the outgoing low voltage circuits will be ABC. These circuits shall be protected by fuses rather than MCCBs. Fuses shall be high rupturing capacity fuses with cartridge type links manufactured in accordance with IEC 60269-1. The fuse link rating shall be in accordance with table 102 below.

**Table 102: Maximum Fuse Link Sizes for ABC Cable**

| Cable Size (mm2) | Maximum Fuse Link Size (A) |
|------------------|----------------------------|
| 50mm2 ABC        | 160                        |
| 95 mm2 ABC       | 250                        |

### 1.11 General Requirement of Distribution Boards

Distribution boards are used to connect customer service cables to distribution cables in underground or overhead systems. The pillar shall be sheet steel, robust, dust, weather and vermin proof, providing a degree of protection of IP 52 for indoor use and IP 54 for outdoor use. Sheet steel used shall be cold rolled, of minimum thickness 2.5 mm, smooth finished and appropriately stiffened to provide adequate strength. There shall be a removable gland plate of minimum 3 mm thickness. The distribution board shall have hinged doors with pad locking facility. Doors and other covers shall be fitted with neoprene gaskets, to satisfy the IP 52 and IP 54 requirements, to prevent ingress of dust, moisture and vermin.

All live parts shall have a minimum phase to phase and phase to earth clearance in air of 25 mm and 20 mm respectively. The removable cable gland plate of 2.5 mm cold rolled sheet steel is included. The interior cabling space is to be as per drawings. Requirements include an external earthing terminal suitable for 19 mm x 6 mm aluminium alloy earthing strip. Provide one number of HRC fuse puller for every distribution board.

The distribution board shall be provided with individual labels with designation or rating. The danger plate, as shown in the drawing, shall be fixed to every pillar door. All labels and plates shall be of corrosion resistant material. Distribution board can be categorized into three types as given in section 4.16.

Pole mounted transformers rated 125 kVA and below shall have the distribution board fixed on the pole or mounting platform. The board shall be supplied complete with a hot dipped galvanised steel fixing assembly, to allow the board to be mounted on one transformer station steel pole, at a height approximately 1200 mm above ground level. Fixing assembly is to fix to poles of diameters ranging from 120 to 300mm. large size distribution boards shall be plinth mounted near the substation. The components of transformer distribution boards are:

- **MCCBs and HRC Fuse**

MCCBs shall be heavy duty type, mounted on bases, having a rupturing capacity of 10kA for transformers rated at 250kVA and 25kA for larger transformers. Outgoing feeders shall be protected by HRC Cartridge Fuse of appropriate capacity of the distribution pillar. The minimum rated breaking capacity of outgoing HRC fuse shall not be below 50kA.

- **Main Busbars**

Main bus bars shall be of aluminium of appropriate size. Bus bars shall be horizontal, but with gradual gradient from front to rear as indicated in the drawing for the different phases. All bus bars shall be solid, without joints and shall be rated for continuous maximum current. The maximum temperature of the bus bars, under operating conditions when carrying rated normal current, shall not exceed 85°C. Bus bars shall be adequately

supported on insulators to withstand dynamic stresses due to short circuit current. Bus bar support insulators shall conform to the relevant applicable Standard. Bus bars shall not be painted and all performance characteristics specified shall be obtained with unpainted. The main bus bar terminating to MCCB shall be with copper of appropriate current rating. Aluminium is not acceptable due to present construction issues where the size of aluminium bar has been reduced at MCCB terminal point to fit in MCCB slot, which gets burnt out over the time due to its reduced bar size.

- **Interior Lighting and Wiring**

Large transformer distribution board shall be provided with two 230V, 50 Hz, 40W, incandescent lamp fixtures, placed diagonally opposite each other, internally at the top of the pillar, for interior illumination and controlled by limit door switch and 2A fuse link. Whereas for small size pillars, one lamp fixtures controlled by limit door switch is sufficient.

**Table 103: Distribution Board Rating for Pole Mounted Transformer**

| Phase | Transformer Rating (kVA) | LV Current (A) | DB Specification  |
|-------|--------------------------|----------------|---|
| 3     | 10                       | 13.91          | TPN DB with 100 amps Bus bar, incomer through 63 amps TP MCCB, 2ways/4ways outgoing with 63amps HRC fuse (6HRC fuses/12HRC fuses) |
| 3     | 16                       | 22.26          | TPN DB with 100 amps Bus bar, incomer through 63 amps TP MCCB, 2ways/4ways outgoing with 63amps HRC fuse (6HRC fuses/12HRC fuses) |
| 3     | 25                       | 34.78          | TPN DB with 100 amps Bus bar, incomer through 63 amps TP MCCB, 2ways/4ways outgoing with 63amps HRC fuse (6HRC fuses/12HRC fuses) |
| 3     | 63                       | 87.65          | TPN DB with 200 amps Bus bar, incomer through 100 amps TP MCCB, 4ways outgoing with 100amps HRC fuse (12HRC fuse)                 |
| 3     | 125                      | 173.91         | TPN DB with 300 amps Bus bar, incomer through 250 amps TP MCCB, 4ways outgoing with 200 amps HRC fuse (12HRC fuse)                |
| 1     | 10                       | 41.67          | SPN with 100 amps Bus bar, incomer through 63 amps SP MCCB, 2ways/3ways outgoing with 63 amps HRC fuse (2HRC fuses/3HRC fuses)    |
| 1     | 16                       | 66.67          | SPN with 100 amps Bus bar, incomer through 100 amps SP MCCB, 2ways/3ways outgoing with 100amps HRC fuse (2HRC fuses/3HRC fuses)   |
| 1     | 25                       | 104.7          | SPN with 200 amps Bus bar, incomer through 160 amps SP MCCB, 3ways outgoing with 100amps HRC fuse (3HRC fuses)                    |

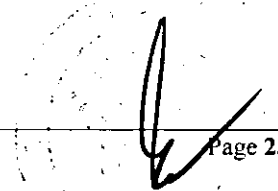

# Transformer Distribution boards for rural network will require 2 spare fuse for connection to new upcoming households.

**Table 104: LV Distribution Board Specification for Pad Mounted Transformer**

| Phase | Transformer Rating (kVA) | LV Current (A) | DB Specification   |
|-------|--------------------------|----------------|--|
| 3     | 250                      | 347.80         | TPN DP with 400 amps Bus bar, 4ways outgoing with 400 amps HRC fuse (12HRC fuse) |
| 3     | 315                      | 438.23         | TPN DP with 600 amps Bus bar, 6ways outgoing with 500 amps HRC fuse (18HRC fuse) |
| 3     | 500                      | 695.60         | TPN DP with 800 amps Bus bar, 6ways outgoing with 800 amps HRC fuse (18HRC fuse) |

Mini Feeder Pillars are used for feeding consumers from Ring /Loop networks. Therefore a mini feeder pillar doesn't have incoming MCCB and outgoing HRC fuse protection. Mini feeder pillar comes with aluminum bus bars with nuts and bolts to connect cable lugs of different sizes. Mini feeder pillar shall also have interior lighting facilities similar to transformer distribution pillar. They shall have a degree of protection of IP 55 or better with bottom cable entry to avoid water ingress. The minimum panel thickness shall be 2.5 mm, and there shall be a removable gland plate of minimum 3 mm thickness. There shall be a lockable hinged door with a minimum thickness of 2 mm. Separate aluminium phase and neutral bus bars shall be provided.

### 1.12 Connection of supply to consumer's premises

Supply to consumer premises through a 2 or 4 core overhead cable in situations where consumers are fed from the overhead system and a 2 or 4 core underground cable when fed from an urban underground system.

Drawing DDCS-BPC-2014-66 shows the connection arrangement for a three phase and single phase consumers. All components except the energy meter shall be provided by the consumer. The energy meter will be provided by BPC.

A new connection should not be livened unless:

- The consumer has installed an MCB as a point of isolation;
- The consumer has installed a stake earth, which is connected to a main earth terminal on the consumer's distribution board;
- There is a link between the earth terminal and the incoming neutral. As shown in the drawing, the configuration of this connection will depend on connection of an ELCB/RCCB.

#### 1.12.1 Consumer Metering

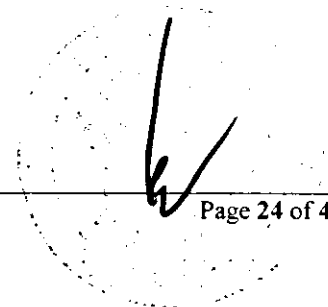

The choice of meter to install in a consumer installation will depend on the expected load. Three types of meter are available:

- Direct connected, where the meter is directly connected to the incoming low voltage supply;
- CT metering, where the meter is indirectly connected to the low voltage supply through a current transformer; and
- High voltage metering, where the consumer is supplied at high voltage and the meter is indirectly connected to the high voltage supply through a high voltage metering unit.

### 1.12.2 Direct Connected Metering

Direct connected metering should be used when the consumer load is does not 60 A. Standard direct connected meters used by BPC are given in Table.

**Table 105: BPC Standard Direct Connected Meters**

| Phase | Meter Type | Capacity (A) | Class |
|-------|------------|--------------|-------|
| 1     | Static     | 10-60Amps    | 2     |
| 3     | Static     | 5-30Amps     | 2     |
|       | Static     | 10-80Amps    | 2     |

The class of meter indicates its accuracy and the meter capacity indicate the current range over which the accuracy can be assured. Hence a class 2 10/60 A meter can be expected to have a metering accuracy of 2% over a current range of between 10 and 60 amps.

### 1.12.3 CT Metering

Where the consumer is supplied at low voltage and the expected maximum three phase load is greater than 60 A, current transformer (CT) metering should be used. All current transformers have a 5 A output and feed into a standard 5 A, class 1 static meter. The load shown on the meter needs to be multiplied by the CT ratio to give the actual consumption.

CTs currently used by BPC have a ratio of 100/5, 200/5, 300/5, 400/5, and 500/5 and have an accuracy of class 1 and a burden of 15 VA.

Care must be taken to ensure the correct multiplier is used when measuring consumption using CT metering.

**Table 106: BPC Standard CT Connected Meters**

| CT class | Meter Type | Capacity (A) | Class |
|----------|------------|--------------|-------|
| X/5      | Static     | 100/5Amps    | 1     |
|          | Static     | 200/5Amps    | 1     |
|          | Static     | 300/5Amps    | 1     |
|          | Static     | 400/5Amps    | 1     |

#### **1.12.4 High Voltage Metering**

Consumers supplied at high voltage must provide a high voltage metering unit acceptable to BPC. The high voltage metering unit shall incorporate both potential and current transformers. The current transformer shall be class 0.5, have a maximum burden of 15 VA and have either a 1 A or 5 A output. The voltage transformer shall be class 0.5, have a maximum burden of 15 VA and have a 110 V output.

BPC will connect its own class 0.5 trivector electronic meter meeting the requirements of IEC 60687 to the consumer's high voltage metering unit. The meter shall incorporate a data logging facility and be capable of recording a range of different power system parameters at the point of connection.

#### **1.13 Underground Cable Installation**

##### **1.13.1 General**

- These notes in general cover cables up to and including 33 kV rating.
- Electrical installation work shall comply with all currently applicable statutes, regulations and safety codes in the locality/country where the installation is to be carried out.
- Installation of cables shall be carried out generally as per IS 1255 or relevant applicable IEC standards and enclosed typical drawings.
- Installation of cables shall include unloading, storing, laying, fixing, jointing, termination and all other work necessary for completing the job. Supply of glands and lugs whenever specified, together with necessary materials for jointing and termination shall also be included in Contractor's scope.
- Construction of cable trenches, provision of embedment and similar work involving civil items will be carried out as per the instructions/notes on the respective project drawings and installation specification.
- Cables will be installed in trenches, trays, racks, tunnels, conduits, duct banks or directly buried. The actual cable layouts will be shown on the relevant drawings. Any changes, if necessary, after obtaining prior approval of the Engineer shall be carried out at site by the Contractor and shall be clearly marked by him on drawings.
- Cables to each circuit shall be laid in one continuous length.
- Where cables are to be installed at temperatures below 3 ° C, they shall be heated to about 10 ° C for not less than 24 hours (in a heated building or in a tent with hot air heater) to facilitate laying (otherwise the bending would damage the insulation and protective

coverings of cables). The cable laying must be carried out swiftly so as not to allow the cable to cool down too much.

- Instead of cast iron cable route marker, plastic marking tape may be used for UG which shall run along the length of the cable and shall have cable marking at every 1.5meter length.

### 1.13.2 Outdoor Cable Installation

- Directly buried cables shall be laid as per the drawings and cable route markers shall be provided. MS cable marker to be replaced by plastic marker buried cables in trefoil formation shall be bound by plastic tapes or 3mm dia. nylon core every 750 mm.
- Joints in directly buried cables shall be identified by joint markers at each joint location.
- In each outdoor cable run greater than 50 meter, some extra cable length shall be kept at a suitable point to enable a straight through joint to be made should the cable develop fault at a later date.
- Where cables cross roads, water or sewage pipes, the cable shall be laid in hume or steel pipes. For road crossings the pipe for the cable shall be buried at not less than 600 mm unless otherwise noted in the drawings. Hume pipes shall be preferred to steel pipes from the point of view of corrosion.
- Control cables and small power cables in trenches and tunnels shall be run in ladder type cable trays (maximum tray width 600 mm) supported on trench/tunnel carrier arms. The cables shall be laid to tray rungs by means of 3mm dia. nylon cord at an interval of 5000 mm and also at bends.
- For good sealing arrangement at entry points, suitable pipe sleeves, adequate in number and of adequate sizes shall be provided in building walls/slabs for passage of cables into a building from cable trays/racks/cable trenches located outside the buildings.

### 1.13.3 Bending Radii for Cables

The bending radii for various types of cables shall not be less than those specified below, unless specifically approved by the Engineer.

| Description                    | Single Core | Multicores<br>Armoured | Multicores<br>Unarmoured |
|--------------------------------|-------------|------------------------|--------------------------|
| PVC insulated cable upto 11 kV | 20 D        | 12 D                   | 15 D                     |

Where D = Overall diameter of cable.



(For XLPE insulated cables, recommendations of manufacturers to be followed).

The above values may be reduced to 70% when making only one bend such as in case of installing an end termination

#### **1.13.4 Terminations Clamping & Miscellaneous Details**

- Cable entry to motors, push button stations and other electrical devices shall be from the bottom as far as possible or from the sides. Top entry shall be avoided particularly for outdoor equipment.
- Identification tags made from aluminium sheet shall be attached to each end of each cable by means of GI binding wire as shown in drawing. Tags shall be additionally put at an interval of 30 meters on long runs of cables and in pull boxes.
- All cable terminations shall be solderless crimping type. Whenever lugs are required to be supplied, adequate size crimping lugs of approved make shall be used by the Contractor. The crimping tools shall be adequate for the lug sizes.
- Wooden cleats when required for vertically supporting on or more single core cables per phase, such as on vertical framework near transformer cable boxes, shall be made out of well seasoned wood given two coats of fire retarding paint of approved quality.

#### **1.13.5 Earthing of Cables**

- Metallic sheaths, screens and armour of all multi-core cables shall be earthed at both equipment and switchgear end.
- Sheath and armour of single core power cables shall be earthed at switchgear end only. If specifically indicated in drawings, for long lengths of cables multiple earthing may have to be adopted to safeguard against the presence of standing voltage under normal as well as fault conditions.
- Earthing of CT and PT neutral lead shall be at one end only.

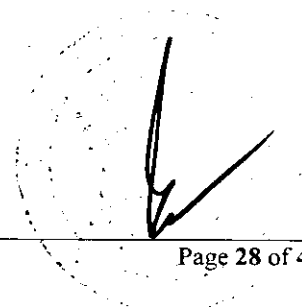

## LIST OF DRAWINGS

| Sl. No. | Drawing no:        | Description  |
|---------|--------------------|--|
| 1       | BPC-DDCS-2015-1    | Underground Cable Installation   |
| 2       | BPC-DDCS-2015-2    | Network Phasing  |
| 3       | BPC-DDCS-2015-3    | Typical Protection Scheme of Power Transformers                            |
| 4       | BPC-DDCS-2015-4    | Typical drawing on energy meter connection                                 |
| 5       | BPC-DDCS-2015-5    | Voltage Selection Scheme   |
| 6       | BPC-DDCS-2015-6    | MV Breaker Scheme for Synchronizing Two Source                             |
| 7       | BPC-DDCS-2015-7    | Arrangements for Underground Distribution System- Residential              |
| 8       | BPC-DDCS-2015-8    | Arrangement for Underground Distribution System- Industrial and Commercial |
| 9       | BPC-DDCS-2015-9    | Termination Pole Substation Type "A" Arrangement                           |
| 10      | BPC-DDCS-2015-10   | Intermediate Pole Substation Type "B" Arrangement                          |
| 11      | BPC-DDCS-2015-11   | Tension Pole Substation Type "C" Arrangement                               |
| 12      | BPC-DDCS-2015-12   | 11 kV, D-ckt Pole Structure  |
| 13      | BPC-DDCS-2015-13   | 33 kV, D-ckt Pole Structure  |
| 14      | BPC-DDCS-2015-14   | LV ABC Typical Service layout Arrangement                                  |
| 15      | BPC-DDCS-2015-15   | LV ABC Intermediate and Angle Pole Details                                 |
| 16      | BPC-DDCS-2015-16   | LV ABC Termination and Anchor Pole Details                                 |
| 17      | BPC-DDCS-2015-17   | LV ABC Tee Pole Details  |
| 18      | BPC-DDCS-2015-18   | 7.5 meter Steel Tubular Pole Assembly Details                              |
| 19      | BPC-DDCS-2015-19   | 7.5 meter Steel Tubular Pole Details                                       |
| 20      | BPC-DDCS-2015-20   | 10 meter Steel Tubular Pole Assembly Details                               |
| 21      | BPC-DDCS-2015-21   | 10 meter Steel Tubular Pole Details  |
| 22      | BPC-DDCS-2015-22   | 12 meter Steel Tubular Pole  |
| 23      | BPC-DDCS-2015-23   | 12 meter Steel Tubular Pole Details  |
| 24      | BPC-DDCS-2015-24   | 11.2 meter Telescopic Pole Details   |
| 25      | BPC-DDCS-2015-25   | 12 meter Telescopic Pole Details   |
| 26      | BPC-DDCS-2015-26   | Foot Bars for Telescopic Poles   |
| 27      | BPC-DDCS-2015-27   | Anti-climbing Device   |
| 28      | BPC-DDCS-2015-28   | Danger Plates  |
| 29      | BPC-DDCS-2015-29   | Clamp Details for Telescopic Pole  |
| 30      | BPC-DDCS-2015-30   | Clamp Details for Steel Tubular Pole                                       |
| 31      | BPC-DDCS-2015-31   | Single Pole Assembly -Steel Tubular Pole                                   |
| 32.     | BPC-DDCS-2015-32/1 | 11 kV & 33 kV H-Frame-Double Pole Arrangement (Steel Tubular Pole)         |
| 33      | BPC-DDCS-2015-32/2 | 11 kV & 33 kV H-Frame-Channel & Bracing Detail (Steel Tubular Pole)        |

34 BPC-DDCS-2015-32/3 11 kV & 33 kV H-Frame-Channel& Bracing Detail (Steel Tubular Pole)

### LIST OF DRAWINGS

| Sl. No. | Drawing no:        | Description   |
|---------|--------------------|---|
| 35      | BPC-DDCS-2015-33/1 | Single Pole Assembly -Telescopic Pole (11.2meter)                             |
| 36      | BPC-DDCS-2015-33/2 | Single Pole Cross-arm Assembly -Telescopic Pole (11.2meter)                   |
| 37      | BPC-DDCS-2015-34/1 | Double Pole Assembly -Telescopic Pole (11.2meter)                             |
| 38      | BPC-DDCS-2015-34/2 | Double Pole Cross-arm Assembly -Telescopic Pole (11.2meter)                   |
| 39      | BPC-DDCS-2015-35/1 | Single Pole Assembly -Telescopic Pole (12meter)                               |
| 40      | BPC-DDCS-2015-35/2 | Single Pole Cross-arm Assembly -Telescopic Pole (12meter)                     |
| 41      | BPC-DDCS-2015-35/3 | U-bolt for Shielding Wire for Single Pole Structure                           |
| 42      | BPC-DDCS-2015-36/1 | Double Pole Cross-arm Assembly -Telescopic Pole (12meter)                     |
| 43      | BPC-DDCS-2015-36/2 | Double Pole Cross-arm Assembly -Telescopic Pole (12meter)                     |
| 44      | BPC-DDCS-2015-36/3 | Double Pole Cross-arm Assembly for Shielding Wire - Telescopic Pole (12meter) |
| 45      | BPC-DDCS-2015-37/1 | Pole Mounted Transformer Structure for Steel Tubular Pole                     |
| 46      | BPC-DDCS-2015-37/2 | Transformer Plateform for Steel Tubular Pole                                  |
| 47      | BPC-DDCS-2015-38/1 | Pole Mounted Transformer Structure for Telescopic Pole (11.2meter)            |
| 48      | BPC-DDCS-2015-38/2 | Pole Mounted Transformer Structure Cross-arm for Telescopic Pole (11.2meter)  |
| 49      | BPC-DDCS-2015-38/3 | Pole Mounted Transformer Structure Cross-arm for Telescopic Pole (11.2meter)  |
| 50      | BPC-DDCS-2015-39/1 | Pole Mounted Transformer Structure for Telescopic Pole (12meter)              |
| 51      | BPC-DDCS-2015-39/2 | Pole Mounted Transformer Structure Cross-arm for Telescopic Pole (12meter)    |
| 52      | BPC-DDCS-2015-39/3 | Pole Mounted Transformer Structure Cross-arm for Telescopic Pole (12meter)    |
| 53      | BPC-DDCS-2015-40/1 | 11 kV and 33 kV ABS Arrangement for Steel Tubular Pole                        |
| 54      | BPC-DDCS-2015-40/2 | ABS Cross-arm Assembly for Steel Tubular Pole                                 |
| 55      | BPC-DDCS-2015-41/1 | 11 kV and 33 kV ABS Arrangement for 11.2M Telescopic Pole                     |
| 56      | BPC-DDCS-2015-41/2 | 11 kV and 33 kV ABS Arrangement for 12M Telescopic Pole                       |

|                |                    |  |
|----------------|--------------------|--|
| 57             | BPC-DDCS-2015-41/3 | ABS Cross-arm Assembly for 11.2M & 12M Telescopic Pole   |
| 58             | BPC-DDCS-2015-42/1 | Typical ARCB Arrangement on Steel Tubular Pole   |
| <b>Sl. No.</b> | <b>Drawing no:</b> | <b>Description</b>   |
| 59             | BPC-DDCS-2015-42/2 | Cross-arm Assembly for Mounting ARCB on Steel Tubular Pole   |
| 60             | BPC-DDCS-2015-43/1 | 33 kV Procelain Pin Insualtor-Large Head   |
| 61             | BPC-DDCS-2015-43/2 | 11 kV Procelain Pin Insualtor- Small Head  |
| 62             | BPC-DDCS-2015-44   | 11 & 33 kV Composite Silicon Rubber Pin Insulator  |
| 63             | BPC-DDCS-2015-45   | Procelain and Composite Silicon Rubber Disc Insulator  |
| 64             | BPC-DDCS-2015-46   | Assemblies for Disc Insulator Arrangement  |
| 65             | BPC-DDCS-2015-47   | Hardware Fittings for Disc Insulator Arrangement   |
| 66             | BPC-DDCS-2015-48   | Stay Insulators  |
| 67             | BPC-DDCS-2015-49   | Spike Earthing Set   |
| 68             | BPC-DDCS-2015-50   | Pipe Earthing Set  |
| 69             | BPC-DDCS-2015-51   | Stay Assembly Set  |
| 70             | BPC-DDCS-2015-52   | General Arrangement of 4 ways Unitized Substation  |
| 71             | BPC-DDCS-2015-53/1 | Single Phase Transformer LT Panel , Incomer MCCB upto 125Amps, HRC Fuse upto 125Amps (Internal View) |
| 72             | BPC-DDCS-2015-53/2 | Single Phase Transformer LT Panel , Incomer MCCB upto 125Amps, HRC Fuse upto 125Amps (External View) |
| 73             | BPC-DDCS-2015-54/1 | Three Phase Transformer LT Panel , Incomer MCCB upto 200Amps, HRC Fuse upto 63Amps (Internal View)   |
| 74             | BPC-DDCS-2015-54/2 | Three Phase Transformer LT Panel , Incomer MCCB upto 200Amps, HRC Fuse upto 63Amps (External View)   |
| 75             | BPC-DDCS-2015-55   | Mini Feeder Pillar 76 BPC-DDCS-2015-56/1 4 Ways Transformer Distribution Pillar (Front Elevation)    |
| 77             | BPC-DDCS-2015-56/2 | 4 Ways Transformer Distribution Pillar (Side Elevation)  |
| 78             | BPC-DDCS-2015-56/3 | 4 Ways Transformer Distribution Pillar (Front Elevation without Door)                                |
| 79             | BPC-DDCS-2015-56/4 | 4 Ways Transformer Distribution Pillar (Gland Plate Details)   |
| 80             | BPC-DDCS-2015-56/5 | 4 Ways Transformer Distribution Pillar (Foundation Details anf Lighting Circuit)                     |
| 81             | BPC-DDCS-2015-57/1 | 6 Ways Transformer Distribution Pillar (Front Elevation)   |
| 82             | BPC-DDCS-2015-57/2 | 6 Ways Transformer Distribution Pillar (Side Elevation)  |
| 83             | BPC-DDCS-2015-57/3 | 6 Ways Transformer Distribution Pillar (Front Elevation without Door)                                |
| 84             | BPC-DDCS-2015-57/4 | 6 Ways Transformer Distribution Pillar (Gland Plate Details)   |
| 85             | BPC-DDCS-2015-57/5 | 6 Ways Transformer Distribution Pillar (Foundation Details and Lighting Circuit)                     |

|    |                      |  |
|----|----------------------|--|
| 86 | BPC-DDCS-2015-58     | Typical Details of 11 kV and 33 kV Fuse Cutout   |
| 87 | BPC-DDCS-2015-59     | Typical Arrangement of 11 kV and 33 kV Air Break Switch  |
| 88 | BPC-DDCS-2015-60/1-2 | Arrangement of Bow Guy and Fly-Guy   |
| 89 | BPC-DDCS-2015-61     | Arrangement of Conductors at Angle Location - 4 pole structure (60 degree to 90 degree location) |
| 90 | BPC-DDCS-2015-62     | Details of Guarding for 11 kV and 33 kV System   |
| 91 | BPC-DDCS-2015-63     | Chain Link Fencing (10 m x 10 m)   |
| 92 | BPC-DDCS-2015-64     | 33 kV /11 kV/.415 kV Substation Pipe Earthing  |
| 93 | BPC-DDCS-2015-65     | Distribution Substation typical Earthing Arrangement   |
| 94 | BPC-DDCS-2015-66     | Consumer Connection Arrangements   |

### LIST OF ABBREVIATIONS

|          |   |
|----------|---|
| BPC      | Bhutan Power Corporation Limited              |
| DDCS     | Distribution Design & Construction Standard   |
| DCSD     | Distribution and Customer Services Department |
| ESD      | Electricity Services Division                 |
| O&M Unit | Operation and Maintenance Unit                |
| TCE      | Tata Consulting Engineers                     |
| ADB      | Asian Development Bank                        |
| LV       | Low Voltage (415 V, 50 Hz)                    |
| MV       | Medium Voltage (6.6 kV, 11 kV, 33 kV)         |
| UG       | Underground                                   |
| ABC      | Aerial Bundled Conductors                     |
| ACSR     | Aluminium Conductor Steel Reinforced          |
| MCCB     | Moulded Case Circuit Breaker                  |
| CB       | Circuit Breaker                               |
| ACB      | Air Break Circuit Breaker                     |
| VCB      | Vacuum Circuit Breaker                        |
| W        | Watts   |
| KW       | Kilo Watts                                    |
| MW       | Mega Watts                                    |

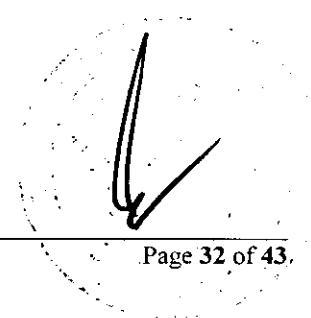

|                 |                                   |
|-----------------|-----------------------------------|
| V               | Volts                             |
| VA              | Volt Amperes                      |
| kV              | Kilo Volts                        |
| kVA             | Kilo Volt Amperes                 |
| PVC             | Poly Vinyl Chloride               |
| XLPE            | Cross Linked Poly ethylene        |
| DO fuse         | Drop out fuse                     |
| HRC fuse        | High Rupturing Capacity fuse      |
| LBS             | Load Break Switch                 |
| CSS             | Compact Secondary Substations     |
| CRMU System     | Closed Ring Main Unit System      |
| RE              | Rural Electrification             |
| SRE             | Sustainable Rural Electrification |
| A               | Amperes                           |
| kA              | Kilo Amperes                      |
| Hz              | Hertz                             |
| GI              | Galvanized Iron                   |
| kPa             | Kilo Pascal                       |
| N               | Newton                            |
| kN              | Kilo Newton                       |
| mm              | Milli meter                       |
| mm <sup>2</sup> | Square milli meter                |
| m               | Meter                             |
| km              | Kilo meter                        |
| rms             | Root Mean Square                  |
| g               | Acceleration due to gravity       |
| ONAN            | Oil Natural Air Natural           |
| ONAF            | Oil Natural Air Forced            |

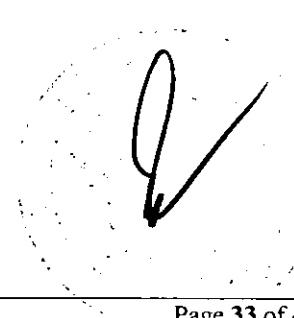

|           |  |
|-----------|--|
| OC        | Degree Celsius   |
| OLTC      | On Load Tap Changer for power transformer                      |
| OCTC      | Off Circuit Tap Changer  |
| MBL       | Minimum Breaking Load  |
| CT        | Current Transformer  |
| PT        | Potential Transformer  |
| SCADA     | Supervisory Control and Data Acquisition                       |
| IDMT      | Inverse Definite Minimum Time                                  |
| DC        | Direct Current   |
| AC        | Alternating Current  |
| LCD       | Liquid Crystal Display   |
| LED       | Light Emitting Diode   |
| SF6       | Sulphur-hexa. Fluoride gas                                     |
| ELCB/RCCB | Earth Leakage Circuit Breaker/Residual Current Circuit Breaker |
| IPC       | Insulation Piercing Connector                                  |
| IEC       | International Electro-technical Commission                     |
| IS        | Indian Standards   |
| CRGO      | Cold Rolled Grain Oriented                                     |
| MRI       | Meter Reading Instrument                                       |
| NVM       | Non-Volatile Memory  |
| GPRS      | General Packet Radio Services                                  |
| GSM       | Global System for Mobile                                       |
| AMR       | Automatic Meter Reading  |
| RMR       | Remote Meter Reading   |
| AAAC      | All Aluminium Alloy Conductor                                  |

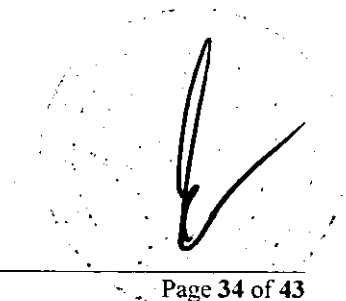

## GLOSSARY OF TERMS

### A

**Altitude (m):** Altitude is the elevation of a given location from sea level, usually measured in meters.

**Ambient temperature (°C):** The temperature of the air, water, or surrounding earth.

**Average annual rainfall (mm):** It is the sum of the monthly rainfall (mm) in a year at a given location divided by (12) twelve.

**Average everyday temperature of conductors (°C):** The daily average temperature experienced by a conductor in its service at a given location.

**ABC:** Stands for Aerial Bundled Cables use for overhead distribution system.

**Armoured Cable:** A cable provided with a wrapping of metal (usually in the form of tape, strip or wire) providing a mechanical protection and earthing of cables.

**AC Resistance and DC Resistance:** The resistance offered by a conductor to the flow of AC current which is more than to DC.

**Auto-Recloser:** A recloser or auto-recloser is a circuit breaker equipped with a mechanism that can automatically close the breaker after it has been opened due to a fault. Reclosers are used on overhead distribution systems to detect and interrupt momentary faults.

**Basic-Impulse Insulation Level (BIL):** It is a test of a factory impulse-voltage waves (about 1.5 x 40 microseconds). It is used to define the ability of the insulation to handle travelling waves coming into a substation over the transmission lines. Line construction is also rated in BIL. Various line insulators all have a BIL rating as well as the type of construction

**Circuit:** Arrangement of conductor(s) for the purpose of carrying electrical energy and forming a system or branched system.

**Conductor:** Any wire, cable, bar, tube, rail or plate used for conducting electricity

**Cable:** A length of single insulated conductor (solid or stranded), or two or more such conductors, each provided with its own insulation, which are laid up together. The insulated conductor or conductors may or may not be provide with an overall mechanical protective covering.

**Circuit breaker:** A circuit breaker is switching device, capable of making, carrying and breaking currents under normal operating conditions, and also making, carrying for a specified time and breaking currents under specified abnormal circuit conditions such as those of short circuit.

**Covered conductor:** A conductor having a specific thickness of insulating material around it.



**DO fuse:** Stands for Drop out fuse. The drop out fuse is a fuse in which the fuse carrier drops into a position to provide an isolating distance after the fuse has operated.

**Distribution Board :** A totally enclosed structure or pillar containing links or fuses for interconnecting distributors.

**Distribution Mains:** The portion of any main with which a service line is, or is intended to be, immediately connected.

**Degree of protection:** Refer IP code - a international Protection Marking, IEC standard 60529, sometimes interpreted as Ingress Protection Marking, classifies and rates the degree of protection provided against intrusion (body parts such as hands and fingers), dust, accidental contact, and water by mechanical casings and electrical enclosures.

**De-rating:** Operating the part at higher values than rated specifications to prolong its life. At higher altitudes, air density decreases; hence the dielectric strength of the air is also reduced and de-rating of the equipment is recommended. Operating clearances (strike distances) must be increased to compensate for the reduction in the dielectric strength of the ambient air. Since the current rating decrease at higher altitude, therefore current de-rating is offset by cooler temperature of the ambient air at higher elevation.

**Earthing/Grounding:** A connection to the general mass of earth by means of an earth electrode. A conducting connection, whether intentional or accidental, by which an electric circuit or equipment is connected to the earth, or to some conducting body or relatively large extent that serves in the place of the earth.

**Earth or ground Electrode:** A conductor or group of conductors in intimate contact with the earth for the purpose for providing a connection with the ground.

**Earthing Conductor:** A metallic conductor for connecting electrical equipment to the earth electrode.

**Electrical clearance:** The shortest distance between two conductive parts (or between a conductive part and the bounding surface of the equipment) measured through air. Clearance distance helps prevent dielectric breakdown between electrodes caused by the ionization of air.

**Factor of Safety:** Safety factor (FoS) is a term describing the structural capacity of a system beyond the expected loads or actual loads.

**Ground Grid:** A system interconnected bare conductors arranged in a pattern over a specified and on or buried below the surface of the earth. The primary purpose of the ground grid is to provide safety for workers by limiting potential differences within its perimeter to safe level in case if high currents which could not flow in the circuit being work became energized for any reasons or if an adjacent energized circuit faulted. Metallic surface mats and gratings are

sometimes utilized for the same purpose. This is not necessarily the same as a signal reference grid.

**High voltage (Hv):** Refers to systems with 66 kV voltages or above.

**Isokeraunic level (thunder days):** The number of thunderstorm days at a given location is known as isokeraunic level.

**IEC:** A standard approved by the International Electro-technical Commission.

**IS:** A standard as approved by Bureau of Indian Standards.

**Insulation Coordination:** The process of correlating the insulation strengths of electric equipment with expected overvoltage and with the characteristics of surge protective devices:

**IP code:** A coding system to indicate the degree of protection provided by an enclosure against access to hazardous parts, ingress of solid foreign objects, ingress of water and to give additional information in connection with such protection

**Low voltage (LV):** Voltage not exceeding 415 volts between phase to phase for three phase supply or 250 volts between phase to neutral in case of single phase supply.

**Load Factor:** The ratio expressed as a numerical value or as a percentage of the energy consumption within a specified period (year, month, day etc) to the energy consumption would result from continuous use of the maximum KW demand occurring within the same period.

**Maximum System Voltage (kV):** The maximum rms voltage which a given electrical system can support in normal operation.

**Minimum temperature of conductors (°C):** The minimum temperature that a conductor shall experience in its service life at a given location.

**Maximum temperature of conductors (°C):** The maximum temperature that a conductor shall experience in its service life at a given location.

**Minimum approach distances:** The minimum approach distance is the closest distance a worker is permitted to approach an exposed energized conductor. Minimum approach distances ensure that workers do not approach or take any conductive object closer to the energized parts.

**Maximum Wind loading on conductors/supports (kPa):** The specified maximum wind load on conductor or support.

**Meter Cupboard:** An enclosure having a locked door and inside which a licensee's energy meters, cutouts and such other apparatus installed.

**Medium voltages (MV):** Refers to systems with 6.6kV or 11kV or 33kV voltage systems.

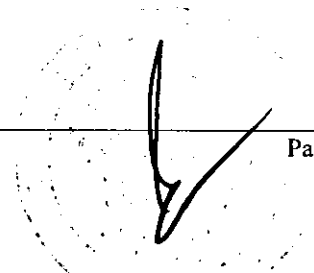

**Nominal System voltage (kV):** A nominal value assigned to designate a system of a given voltage class. It is the system voltage by which the system may be designated, and to which certain operating characteristics of the system are related.

**Nominal System Frequency (Hz):** A nominal value assigned to designate a system of a given frequency class.

**ONAN:** It stands for Oil Natural Air Natural, where the cooling oil and air are naturally circulated without any additional circulation arrangement. It is one of the methods of cooling Distribution Power Transformer.

**ONAF:** It stands for Oil Natural Air Forced, where the circulation of oil is natural but the circulation of air is done with the help of a fan. This is another type of cooling method for Distribution Power Transformer.

**Overload:** Operating conditions in an electrically undamaged circuits, which causes an overcurrent.

**Over current:** Any current in excess of the rated current of equipment or the ampacity of a conductor. It may result from overload, short circuit or ground fault.

**Overhead line:** Electric supply line which is placed above ground and in open air but excluding live rails of a traction system.

**Power transformer:** A static piece of apparatus with two or more windings which, by electromagnetic induction, transforms a system of alternating voltage and current into another system of voltage and current usually of different values and at the same frequency for the purpose of transmitting electrical power.

**Power factor (pf):** The ratio of Active Power (KW) to Apparent Power (KVA).

**Relative humidity:** The amount of moisture content in atmosphere at a given location expressed in percentage.

**Rated Impulse Withstand voltage (kV<sub>peak</sub>):**

The maximum crest value of an applied impulse voltage which does not cause a flashover, puncture, or disruptive discharge on the test specimen like circuit breaker.

**Rated one minute Power Frequency Withstand voltage (kV):** The specified rms test voltage at power frequency that will not cause a disruptive discharge when applied on the specimen for one minute.

**Rated one second short time current (kA):** It is that short time rms current which a system can carry safely for a period of 1 sec.

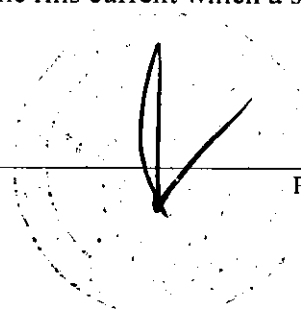

**Rated short circuit withstand current ( $kA_{peak}$ ):** The maximum crest value of a short circuit current that a system can withstand safely.

**Rated bus bar current (A):** It is that rms value of current that a bus bar can carry safely.

**Rated circuit current (A):** It is that rms value of current that an electrical circuit can carry safely.

**Rated short circuit breaking current (kA):** The peak value of short circuit current that a switching device can break without causing any damage to it, under prescribed conditions of use and behavior.

**Rated peak making current ( $kA_{peak}$ ):** The highest value of current in the pole of a switching device when the current is established by the closing of the device, under prescribed conditions of use and behavior.

**Rated voltage:** The rated voltage is the maximum rms. value of the voltage that the equipment can withstand in normal service.

**Sub transmission system or Distribution system:** Any system consisting mainly of overhead, cable, and service lines, electrical plant and meters having design voltage of 33 KV and below owned or operated by a licensee for distribution or for retail supply and used for the transportation of electricity from a transmission system or generating sets or other points to the point of delivery to consumers, and includes any electrical plant and meters owned or operated by the licensee in connection with the distribution of electricity. The distribution system shall not include any part of a transmission system, except where used for the supply of electricity to a single consumer or group of consumers.

**Seismic acceleration level:** It is the acceleration of the ground movement at a location, that take place due to earthquake, expressed in terms of the acceleration due to gravity (g).

**Snow incidence in winter (mm):** The range of the amount of snow fall in winter at a given location expressed in millimeters (mm).

**Surge Arrestor:** A protective device for limiting surge voltages on equipment by discharging or bypassing surge current; it prevents continued flow of follow current to ground, and is capable of repeating these functions as specified.

**Short Circuit:** The connection of two or more points of a circuit through negligible impedance.

**Short Circuit Current (kA):** An over current resulting from a short circuit due to a fault or an incorrect connection in an electric circuit.

**Service Line:** Any electric supply line through which electrical energy is or is intended to be, supplied by a licensee.

- a) To a single consumer either from a distributing main or immediately from the licensee's premises, or

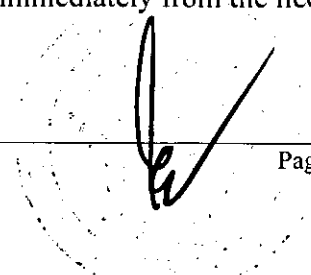

- b) From a distributing main to a group of consumer on the same premises or on adjoining premises

supplied from the same point of the distributing mains.

**Sealing Ends (sealing box or sealing Chamber):** A close box fitted to one end of a cable or external connection, in such a manner as to protect the insulation of cable from air or moisture.

**Switchgear:** It is a general term covering switching devices and assemblies of such devices with associated inter-connections and accessories.

**Switch:** A switch is a switching device capable of making, carrying and breaking currents under normal circuit conditions, which may include specified operating overload conditions and also carrying for a specified time currents under specified abnormal circuit conditions such as those of a short circuit. A switch is thus by definition, not intended to make or break fault currents.

**Switch fuse:** A switch fuse is a switch in which one or more poles have a fuse in series in a composite unit, so that high fault currents are cleared by operation of the fuse.

**Solidly Grounded:** Grounded through an adequate ground connection in which no impedance has been inserted intentionally

**Sectional clearance:** Sectional clearance is the distance between the live parts of the phases and the terminals of the work section. The work section or maintenance section may be a platform or ground on which operation personnel can carry out his task safely.

**Unarmoured cable:** A cable without a wrapping of metal unlike the armoured cable.

**Underground cable:** An armoured cable of a given size which can be laid in the ground for the purpose of carrying electric current.

**Underground Lines:** An electric line laid in the ground using adequate size of an armoured underground cable.

**Voltage Drop:** The loss of voltage between the input to a system/device and the output from a system/ device due to the internal impedance or resistance of the system/device. In all electrical systems, the conductors should be sized so that the voltage drop never exceeds 3% for power, heating, and lighting loads or combinations of these. Furthermore, the maximum total voltage drop for conductors for feeders and branch circuits combined should never exceed 5%.

**Voltage Fluctuation:** Voltage Fluctuations are systematic variations of the voltage envelope or a series of random voltage changes, the magnitude of which does not normally exceed the voltage range.

**Wind pressure (kPa):** The force exerted per unit area of a surface by windblown in that location.

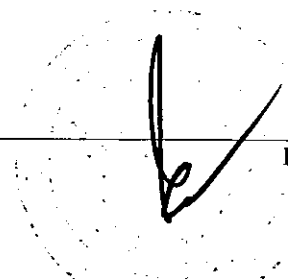

## LIST OF REFERENCES

### 1 Reports

- a) Worley International Ltd: ADB TA 2043-BHU Power System Development Project: Final Report, January 1995.
- b) Worley International Ltd: ADB Loan No. 1375-BHU Rural Electrification Project Construction Manual for Rural Electrification Works, October 1996.
- c) Department of Power, Ministry of Trade & Industry, Royal Government of Bhutan: Basic Standards, Guide lines and Cost Estimation for infrastructure construction pertaining to power Sub-transmission and Distribution, 1998.
- d) Tata Consulting Engineers (TCE): ADB TA 2912-BHT Second Rural Electrification Project: Final Report, October 1999.
- e) Tata Consulting Engineers Ltd (TCE): ADB Loan 1712-BHU, Sustainable Rural Electrification Project: Design and Construction Manual, May 2002.
- f) SMEC International Pty Ltd: ADB TA 3825-BHU, Rural Electrification and Network Expansion Project: Final Report, September 2003.
- g) Bhutan Electricity Authority (Distribution Code), 2008.
- h) Rural electrification of Lingshi at an altitude of 4850meters above sea level. The lines have been designed based on the local condition of that specific place. This is the highest altitude where BPC's equipment has been installed.

### 2 Standard Documents

- a) IS 3961 (Part II)-1967 (reaffirmed 2001): Recommended Current Ratings for Cables
- b) S 1255-1983 (Reaffirmed 2001): Code of practice for Installation and maintenance of power cable up to and including 33 kV Rating.
- c) IS 3043-1997 (Reaffirmed 2001): Code of practice for earthing.
- d) IS 5613 (PART 2/Sec 1)-1985 (reaffirmed 2002): Code of practice for design, installation and maintenance of overhead power lines above 11 kV and up to and including 220 kV.
- e) IS 8061-1976 (Reaffirmed 2001): Code of practice for design, installation and maintenance of service lines up to and including 650 V.

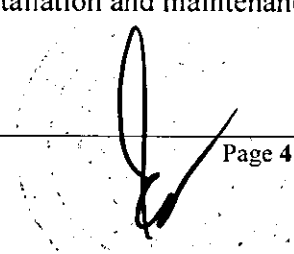

- f) IS 1885 (Part 54)-1993 (Reaffirmed 2004): Electro technical Vocabulary-Insulators
- g) IS 1885 (Part XXX)-1971(Reaffirmed 2002): Electro technical Vocabulary-Overhead Transmission and Distribution of Electrical Energy.
- h) IS 1885 (Part 32)-1993(Reaffirmed 2004): Electro technical Vocabulary-Electric Cables.
- i) IS 1885 (Part 28)-1993(Reaffirmed 2004): Electro technical Vocabulary-Instrument Transformers.
- j) IS 1885 (Part 38)-1993(Reaffirmed 2004): Electro technical Vocabulary-Power Transformers and Reactors.
- k) IS 1885 (Part 10)-1993(Reaffirmed 2004): Electro technical Vocabulary-Power System Protection.
- l) IS 1885 (Part XVII)-1979(Reaffirmed 2002): Electro technical Vocabulary-Switchgear and Control gear.
- m) IS 2713: Steel Tubular Poles.
- n) IEC 60076 Parts 1-5 : Power Transformers.
- o) IEC 60214: Power Transformer Tap Changers.
- p) IEC 60296: Insulating Oil for Power Transformers.
- q) IEC 60466, IEC 60694, IEC 62271-100: Medium Voltage Circuit Breakers.
- r) IEC 60383-1 and ANSI C29.6: 11 kV & 33 kV Pin Insulators.
- s) IEC 60305, IEC 60383-2: 11 kV Disk Insulators.
- t) ANSI C29.4: Guy Insulators.
- u) IEC 60076: Distribution Transformers.
- v) IEC 60099-4: Surge Arrestors.
- w) IEC 62271-100 and ANSI C37.60 : Auto-Reclosers
- x) IEC 60282-2: MV Drop Out Fuses.
- y) IEC 60271-102 and IEC 60265-1: MV Load Break Switches.
- z) IS 2713: Steel Tubular Poles.
- aa) Pirelli Cables catalogue: 11 kV characteristics.
- ab) Olex Cables catalogue : LV three phase and single phase underground cables
- ac) ABB Limited: Catalogue regarding Compact Secondary Substations (CSS).
- ad) ABB Limited: Catalogue regarding Closed Ring Main Units Systems (RMU).

### **3 Electrical Engineering Text books/Manuals**

- a) Khana Publishers: Hand book of Electrical Engineering by S.L. Bhatia, 6th Edition- third Reprint 2004 b) Manual on Transformers, CBIP Publication.





**BHUTAN POWER CORPORATION LIMITED**



**DISTRIBUTION DESIGN AND CONSTRUCTION  
STANDARDS Second Edition, 2016**

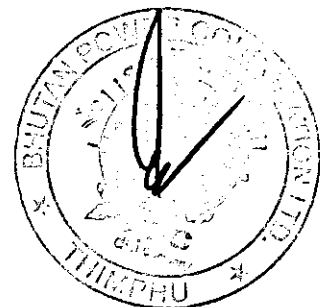

| Sl. No. | Drawing no:        | Description  |
|---------|--------------------|--|
| 35      | BPC-DDCS-2015-33/1 | Single Pole Assembly -Telescopic Pole (11.2meter)                            |
| 36      | BPC-DDCS-2015-33/2 | Single Pole Cross-arm Assembly -Telescopic Pole (11.2meter)                  |
| 37      | BPC-DDCS-2015-34/1 | Double Pole Assembly -Telescopic Pole (11.2meter)                            |
| 38      | BPC-DDCS-2015-34/2 | Double Pole Cross-arm Assembly -Telescopic Pole (11.2meter)                  |
| 39      | BPC-DDCS-2015-35/1 | Single Pole Assembly -Telescopic Pole (12meter)                              |
| 40      | BPC-DDCS-2015-35/2 | Single Pole Cross-arm Assembly -Telescopic Pole (12meter)                    |
| 41      | BPC-DDCS-2015-35/3 | U-bolt for Shielding Wire for Single Pole Structure                          |
| 42      | BPC-DDCS-2015-36/1 | Double Pole Cross-arm Assembly -Telescopic Pole (12meter)                    |
| 43      | BPC-DDCS-2015-36/2 | Double Pole Cross-arm Assembly -Telescopic Pole (12meter)                    |
| 44      | BPC-DDCS-2015-36/3 | Double Pole Cross-arm Assembly for Shielding Wire -Telescopic Pole (12meter) |
| 45      | BPC-DDCS-2015-37/1 | Pole Mounted Transformer Structure for Steel Tubular Pole                    |
| 46      | BPC-DDCS-2015-37/2 | Transformer Plateform for Steel Tubular Pole                                 |
| 47      | BPC-DDCS-2015-38/1 | Pole Mounted Transformer Structure for Telescopic Pole (11.2meter)           |
| 48      | BPC-DDCS-2015-38/2 | Pole Mounted Transformer Structure Cross-arm for Telescopic Pole (11.2meter) |
| 49      | BPC-DDCS-2015-38/3 | Pole Mounted Transformer Structure Cross-arm for Telescopic Pole (11.2meter) |
| 50      | BPC-DDCS-2015-39/1 | Pole Mounted Transformer Structure for Telescopic Pole (12meter)             |
| 51      | BPC-DDCS-2015-39/2 | Pole Mounted Transformer Structure Cross-arm for Telescopic Pole (12meter)   |
| 52      | BPC-DDCS-2015-39/3 | Pole Mounted Transformer Structure Cross-arm for Telescopic Pole (12meter)   |
| 53      | BPC-DDCS-2015-40/1 | 11 kV and 33 kV ABS Arrangement for Steel Tubular Pole                       |
| 54      | BPC-DDCS-2015-40/2 | ABS Cross-arm Assembly for Steel Tubular Pole                                |
| 55      | BPC-DDCS-2015-41/1 | 11 kV and 33 kV ABS Arrangement for 11.2M Telescopic Pole                    |
| 56      | BPC-DDCS-2015-41/2 | 11 kV and 33 kV ABS Arrangement for 12M Telescopic Pole                      |
| 57      | BPC-DDCS-2015-41/3 | ABS Cross-arm Assembly for 11.2M & 12M Telescopic Pole                       |
| 58      | BPC-DDCS-2015-42/1 | Typical ARCB Arrangement on Steel Tubular Pole                               |
| 59      | BPC-DDCS-2015-42/2 | Cross-arm Assembly for Mounting ARCB on Steel Tubular Pole                   |
| 60      | BPC-DDCS-2015-43/1 | 33 kV Procelain Pin Insulator-Large Head                                     |
| 61      | BPC-DDCS-2015-43/2 | 11 kV Procelain Pin Insulator- Small Head                                    |
| 62      | BPC-DDCS-2015-44/1 | & 33 kV Composite Silicon Rubber Pin Insulator                               |
| 63      | BPC-DDCS-2015-45   | Procelain and Composite Silicon Rubber Disc Insulator                        |
| 64      | BPC-DDCS-2015-46   | Assembly for Disc Insulator Arrangement                                      |
| 65      | BPC-DDCS-2015-47   | Hardware Fittings for Disc Insulator Arrangement                             |
| 66      | BPC-DDCS-2015-48   | Stay Insulator   |
| 67      | BPC-DDCS-2015-49   | Spike Earthing Set   |

| Sl. No. | Drawing no:          | Description  |
|---------|----------------------|--|
| 68      | BPC-DDCS-2015-50     | Pipe Earthing Set  |
| 69      | BPC-DDCS-2015-51     | Stay Assembly Set  |
| 70      | BPC-DDCS-2015-52     | General Arrangement of 4 ways Unitized Substation  |
| 71      | BPC-DDCS-2015-53/1   | Single Phase Transformer LT Panel , Incomer MCCB upto 125Amps, HRC Fuse upto 125Amps (Internal View) |
| 72      | BPC-DDCS-2015-53/2   | Single Phase Transformer LT Panel , Incomer MCCB upto 125Amps, HRC Fuse upto 125Amps (External View) |
| 73      | BPC-DDCS-2015-54/1   | Three Phase Transformer LT Panel , Incomer MCCB upto 200Amps, HRC Fuse upto 63Amps (Internal View)   |
| 74      | BPC-DDCS-2015-54/2   | Three Phase Transformer LT Panel , Incomer MCCB upto 200Amps, HRC Fuse upto 63Amps (External View)   |
| 75      | BPC-DDCS-2015-55     | Mini Feeder Pillar   |
| 76      | BPC-DDCS-2015-56/1   | 4 Ways Transformer Distribution Pillar (Front Elevation)   |
| 77      | BPC-DDCS-2015-56/2   | 4 Ways Transformer Distribution Pillar (Side Elevation)  |
| 78      | BPC-DDCS-2015-56/3   | 4 Ways Transformer Distribution Pillar (Front Elevation without Door)                                |
| 79      | BPC-DDCS-2015-56/4   | 4 Ways Transformer Distribution Pillar (Gland Plate Details)   |
| 80      | BPC-DDCS-2015-56/5   | 4 Ways Transformer Distribution Pillar (Foundation Details and Lighting Circuit)                     |
| 81      | BPC-DDCS-2015-57/1   | 6 Ways Transformer Distribution Pillar (Front Elevation)   |
| 82      | BPC-DDCS-2015-57/2   | 6 Ways Transformer Distribution Pillar (Side Elevation)  |
| 83      | BPC-DDCS-2015-57/3   | 6 Ways Transformer Distribution Pillar (Front Elevation without Door)                                |
| 84      | BPC-DDCS-2015-57/4   | 6 Ways Transformer Distribution Pillar (Gland Plate Details)   |
| 85      | BPC-DDCS-2015-57/5   | 6 Ways Transformer Distribution Pillar (Foundation Details and Lighting Circuit)                     |
| 86      | BPC-DDCS-2015-58     | Typical Details of 11 kV and 33 kV Fuse Cutout   |
| 87      | BPC-DDCS-2015-59     | Typical Arrangement of 11 kV and 33 kV Air Break Switch  |
| 88      | BPC-DDCS-2015-60/1-2 | Arrangement of Bow Guy and Fly-Guy   |
| 89      | BPC-DDCS-2015-61     | Arrangement of Conductors at Angle Location - 4 pole structure (60 degree to 90 degree location)     |
| 90      | BPC-DDCS-2015-62     | Details of Guarding for 11 kV and 33 kV  |
| 91      | BPC-DDCS-2015-63     | System Chain Link Fencing (10 m x 10 m)  |
| 92      | BPC-DDCS-2015-64     | 33 kV /11 kV/.415 kV Substation Pipe Earthing  |
| 93      | BPC-DDCS-2015-65     | Distribution Substation typical Earthing   |
| 94      | BPC-DDCS-2015-66     | Arrangement Consumer Connection Arrangement  |

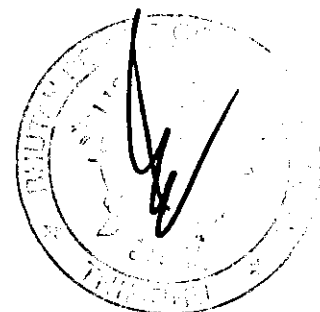

INSTALLATION OF DIRECTLY BURIED CABLES

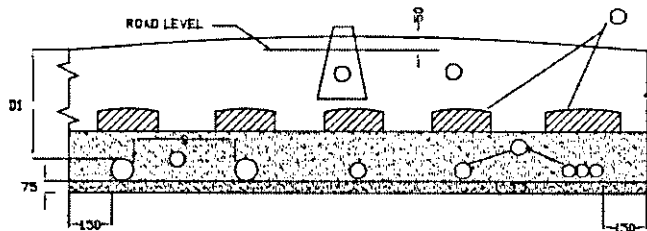

DIRECTLY BURIED CABLES IN SINGLE LAYER

LEGEND

- (1) - CABLE ROUTE MARKER IF PROVIDED..
- (2) - EARTH BACK FILLED & RAMMED.
- (3) - PROTECTIVE COVERS, AS PER IS 1255  
- RCC/SLABS/BRICKS FOR HIGH VOLTAGE CABLES
- (4) - ARMoured POWER CABLE
- (5) - FINE SAND/ RIDDLED SOIL COMPACTED.
- (6) - SAND BEDDING

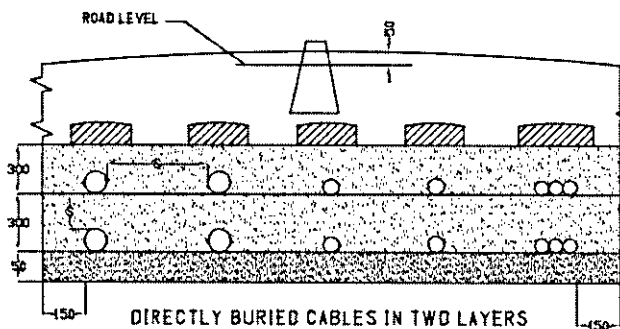

DIRECTLY BURIED CABLES IN TWO LAYERS

| DIMENSION (MIN) | 1100V GRADE CABLES   | 11KV | 33kV |
|-----------------|--|------|------|
| D1              | 600  | 1000 | 1000 |
| S               | d - BETWEEN CABLES OF SAME CLASS<br>* 300mm - BETWEEN CABLES OF DIFFERENT CLASS<br>* 400mm - BETWEEN 1-CORE POWER CABLE AND COMMUNICATION CABLE<br>* 400mm - BETWEEN MULTICORE POWER CABLE AND COMMUNICATION CABLE |      |      |

- d. - OVER ALL DIAMETER OF THE BIGGER OF THE TWO CABLE
- \* - SPACING SHALL BE KEPT BOTH HORIZONTALLY AND VERTICALLY

NOTE

1. SINGLE CORE CABLES SHALL BE RUN IN TREFOIL FORMATION AND SHALL BE BOUND BY PLASTIC TAPES OR 3mm DIA NYLON CORE EVERY 750mm
2. PLASTIC MARKING TAPE TO BE USED FOR UG WHICH SHALL RUN ALONG THE LENGTH OF THE CABLE AND SHALL HAVE CABLE MARKING AT EVERY 1.5METER LENGTH
3. CABLE IDENTIFICATION TAG SHALL BE TIED AT BOTH ENDS OF THE CABLE AND ALSO AT AN INTERVAL OF 15 METRES.
4. IF THE MINIMUM CLEARANCE AS INDICATED IN THE ABOVE TABLE FOR CABLES OF DIFFERENT CLASSES ARE NOT FEASIBLE, BRICK BARRIERS SHALL BE USED BETWEEN ADJACENT CABLES.
5. GI/HUME PIPE SHALL BE PROVIDED FOR ROAD CROSSING.

|  |   |               |
|--|---|---------------|
|  BHUTAN POWER CORPORATION LIMITED | ENGINEERING DESIGN & CONTRACTS DEPARTMENT           |               |
|  | TITLE : DISTRIBUTION DESIGN & CONSTRUCTION STANDARD |               |
| DESIGNED BY  | NAME  | DATE          |
| CHECKED BY   |   |               |
| APPROVED BY  |   |               |
| INSTALLATION PRACTICE - DIRECTLY BURIED CABLES   |   |               |
| DRAWING NO. BPC-DOCS-2015-1  |   | REVISION 2015 |

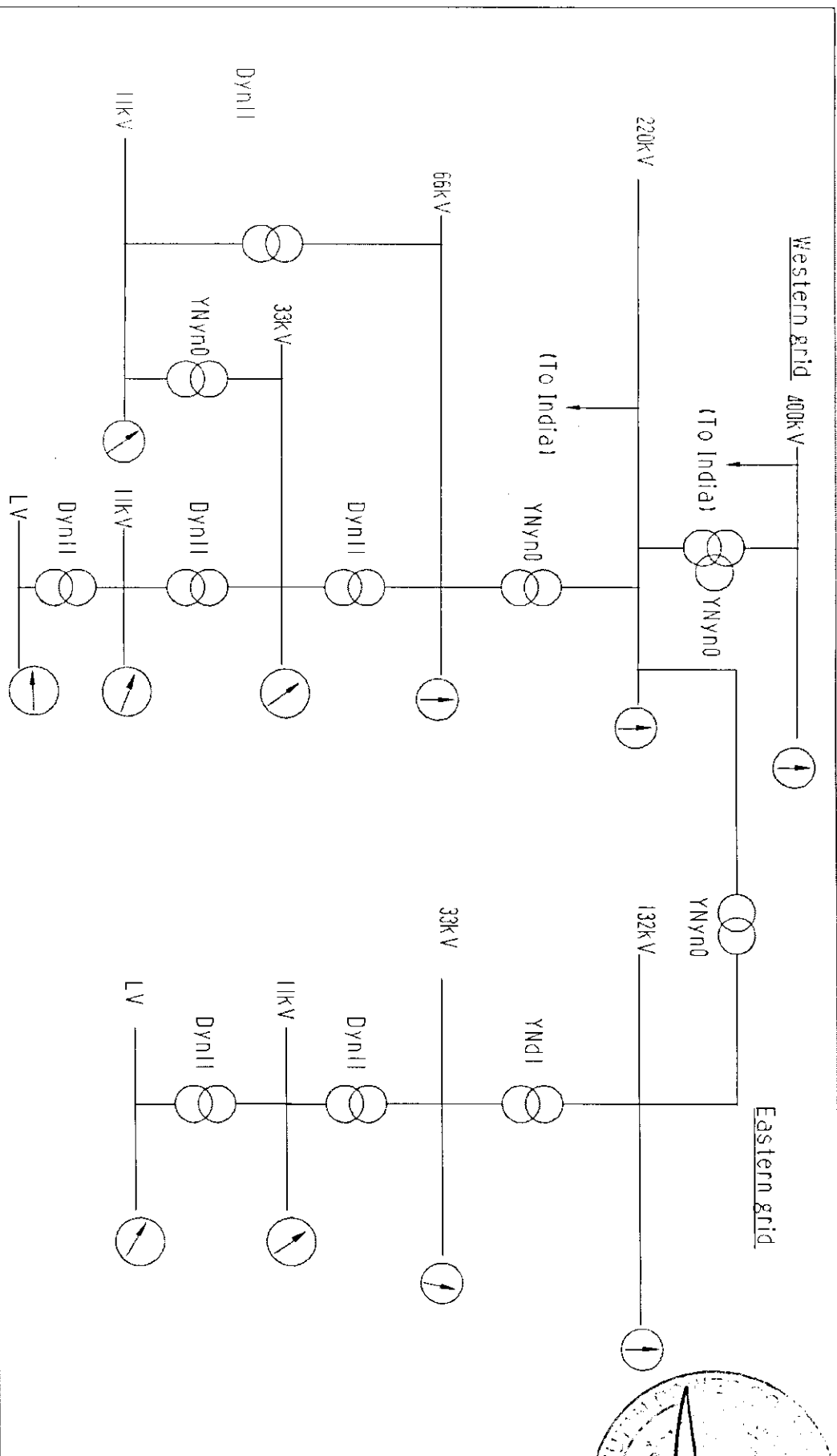

|   |  |   |               |
|---|--|---|---------------|
|  |  | <b>BHUTAN POWER CORPORATION LIMITED</b>               |               |
| <b>ENGINEERING DESIGN &amp; CONTRACTS DEPARTMENT</b>                              |  | <b>ENGINEERING DESIGN &amp; CONSTRUCTION STANDARD</b> |               |
| <b>DISTRIBUTION DESIGN &amp; CONSTRUCTION STANDARD</b>                            |  | <b>NETWORK PHASING</b>                                |               |
| TITLE<br>NAME<br>DATE   | DESIGNED BY<br>CHECKED BY<br>APPROVED BY | DRAWING NO. BPC-DDCS-2015-2                           | REVISION 2015 |

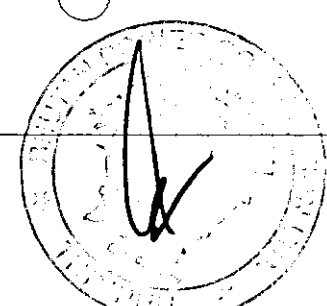

Primary Bus

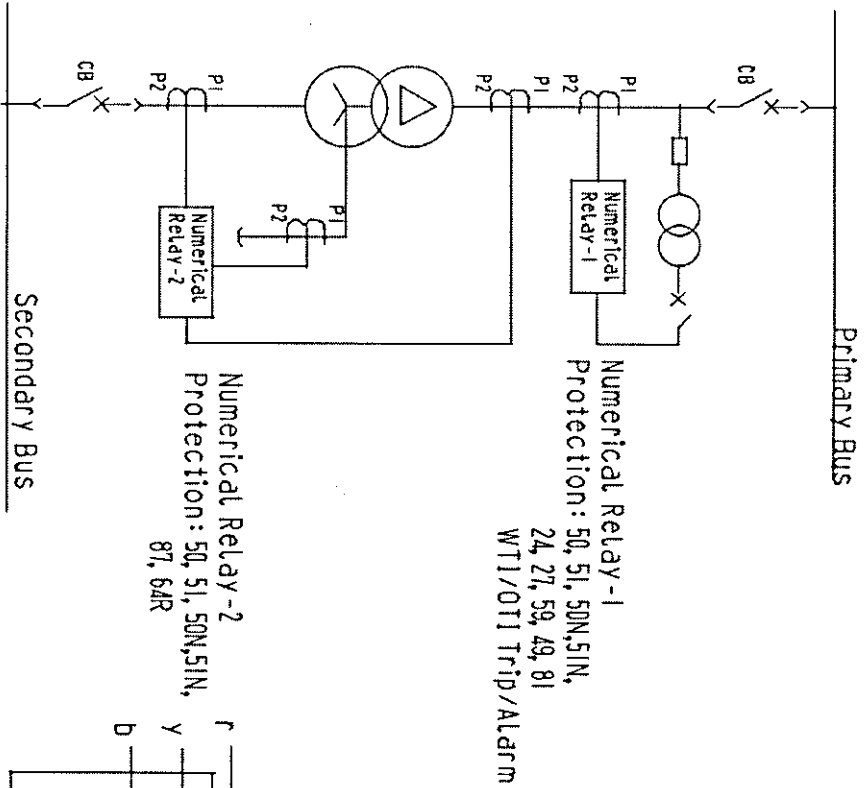

**RESTRICTED EARTH-FAULT PROTECTION FOR STAR WINDING**

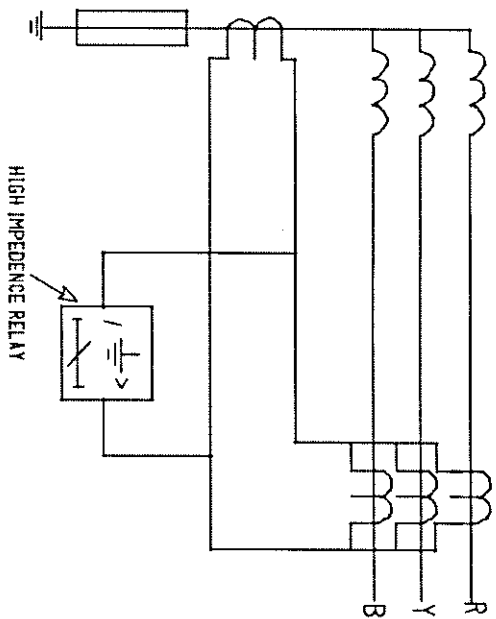

**DIFFERENTIAL PROTECTION FOR 2 WINDING DELTA-STAR TRANSFORMER**

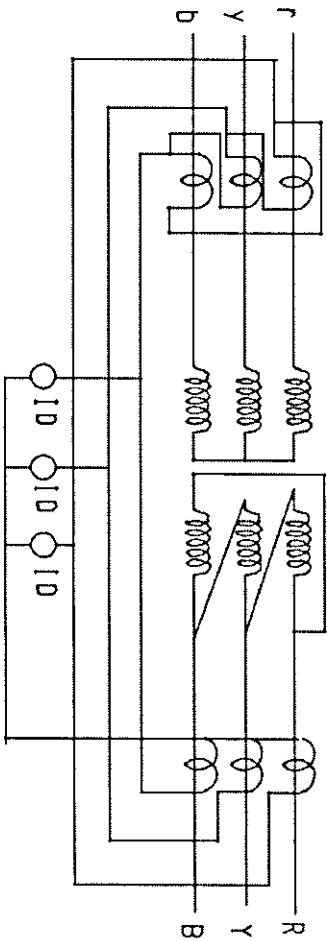

|   |      |  |      |
|---|------|--|------|
|  |      | <b>BHUTAN POWER CORPORATION LIMITED</b>                |      |
| TITLE   | NAME | DATE   |      |
| DESIGNED BY   |      |  |      |
| CHECKED BY  |      |  |      |
| APPROVED BY   |      |  |      |
| <b>ENGINEERING DESIGN &amp; CONTRACTS DEPARTMENT</b>                              |      | <b>DISTRIBUTION DESIGN &amp; CONSTRUCTION STANDARD</b> |      |
| <b>TYPICAL PROTECTION SCHEME FOR 33/11 KV TRANSFORMER</b>                         |      | <b>DRAWING NO. BPC-DDCS-2015-3</b>                     |      |
|   |      | REVISION   | 2015 |

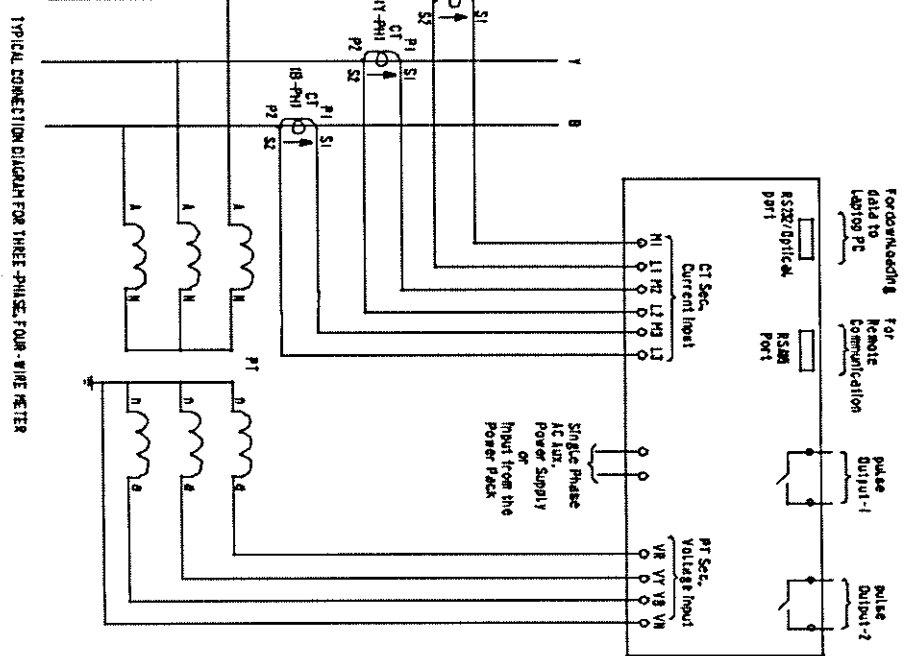
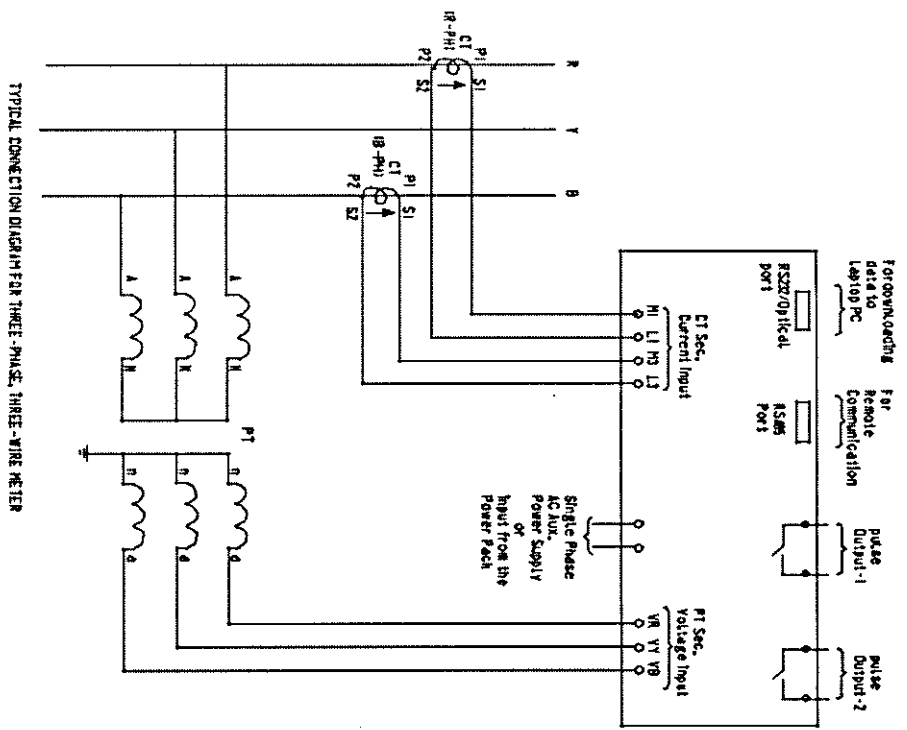

TYPICAL CONNECTION DIAGRAM FOR THREE-PHASE, THREE-WIRE METER

TYPICAL CONNECTION DIAGRAM FOR THREE-PHASE, FOUR-WIRE METER

|   |             |   |                 |
|---|-------------|---|-----------------|
| <p><b>BHUTAN POWER CORPORATION LIMITED</b></p>                |             | <p><b>ENGINEERING DESIGN &amp; CONTRACTS DEPARTMENT</b></p> |                 |
| <p>TITLE</p>  | <p>NAME</p> | <p>DATE</p>   | <p>REVISION</p> |
| <p>DESIGNED BY</p>  |             |   | <p>2015</p>     |
| <p>CHECKED BY</p>   |             |   |                 |
| <p>APPROVED BY</p>  |             |   |                 |
| <p><b>DISTRIBUTION DESIGN &amp; CONSTRUCTION STANDARD</b></p> |             | <p><b>TYPICAL DRAWING ON MV ENERGY METER CONNECTION</b></p> |                 |
| <p><b>DRAWING NO. BPC-DDCS-2015-4</b></p>                     |             | <p><b>REVISION 2015</b></p>                                 |                 |

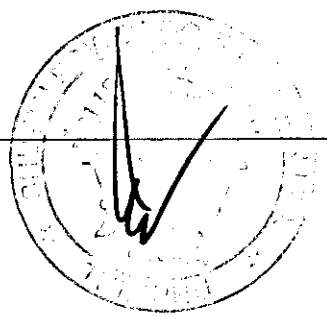

1. VOLTAGE SELECTION USING BUS-COUPLER AUXILIARY SWITCH

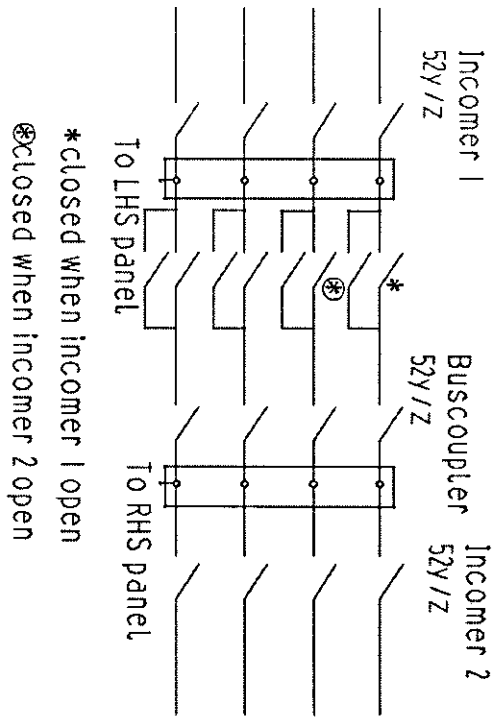

2. VOLTAGE SELECTION USING UNDERVOLTAGE RELAY

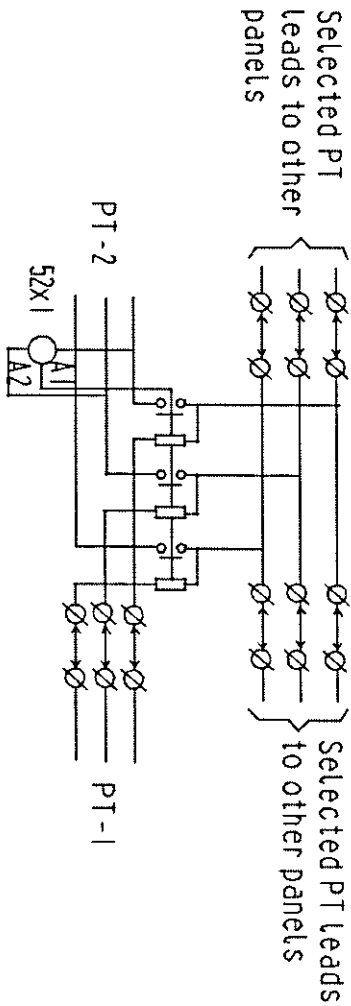

|  |  |  |  |
|--|--|--|--|
| <br><b>BHUTAN POWER CORPORATION LIMITED</b> |  | <b>ENGINEERING DESIGN AND CONTRACTS DEPARTMENT</b>     |  |
| <b>TITLE</b>   |  | <b>NAME</b>  |  |
| <b>DESIGNED BY</b>   |  | <b>DATE</b>  |  |
| <b>CHECKED BY</b>  |  | <b>DISTRIBUTION DESIGN &amp; CONSTRUCTION STANDARD</b> |  |
| <b>APPROVED BY</b>   |  | <b>VOLTAGE SELECTION SCHEME</b>                        |  |
| <b>DRAWING NO. BPC - DDCS - 2015 - 5</b>   |  | <b>REVISION 2015</b>                                   |  |



**BREAKER SCHEME WITH FEEDER PI**

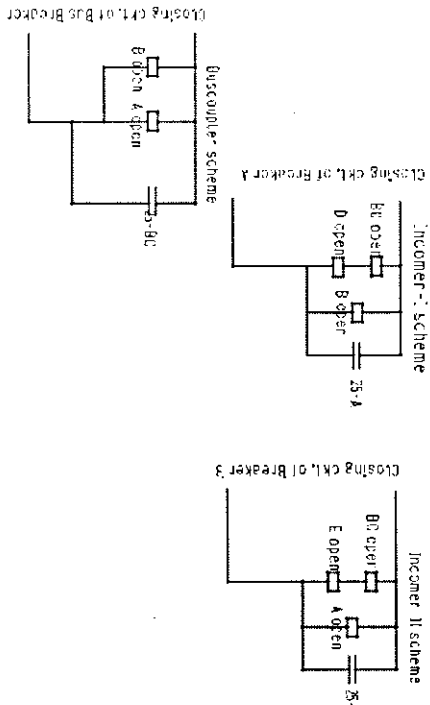
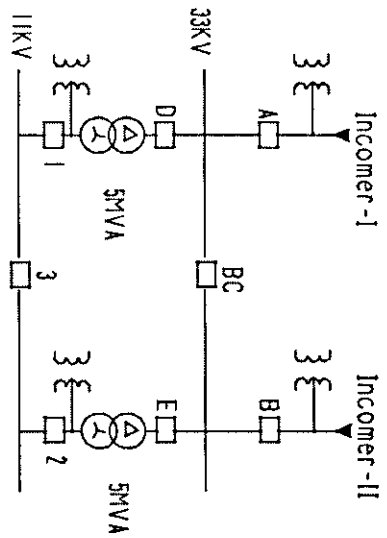

**BREAKER SCHEME WITH BUS PI**

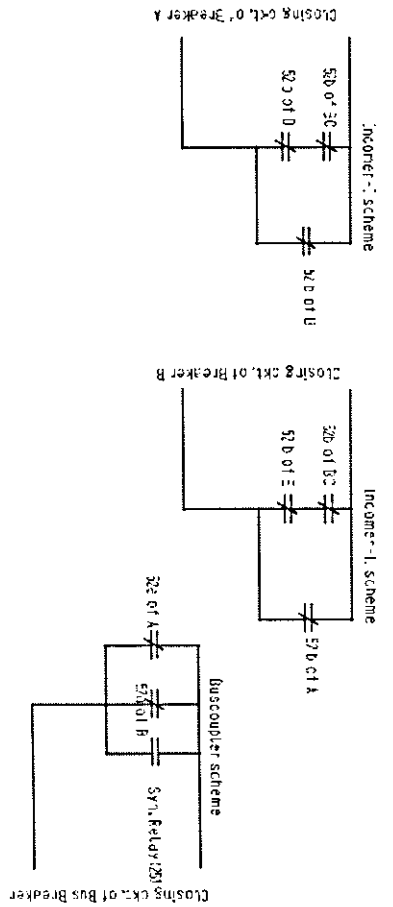
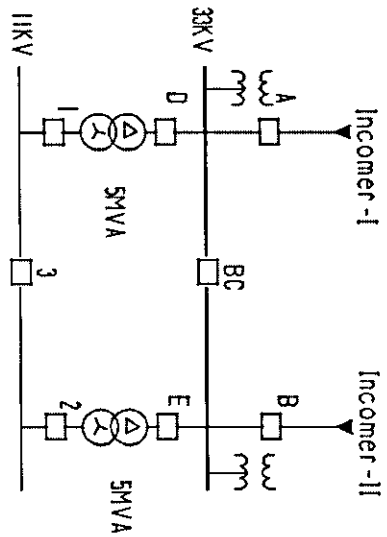

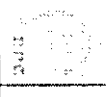
|  |      |  |                      |
|--|------|--|----------------------|
| <br><b>BHUTAN POWER CORPORATION LIMITED</b> |      | <b>ENGINEERING DESIGN &amp; CONTRACTS DEPARTMENT</b> |                      |
| TITLE  | NAME | DATE   |                      |
| DESIGNED BY  |      |  |                      |
| CHECKED BY   |      |  |                      |
| APPROVED BY  |      |  |                      |
| <b>DISTRIBUTION DESIGN &amp; CONSTRUCTION STANDARD</b><br><b>MV BREAKER SCHEME FOR SYNCHRONISING TWO SOURCE</b>              |      |  | <b>REVISION 2015</b> |
| <b>DRAWING NO. BPC-DCCS-2015-6</b>   |      |  |                      |

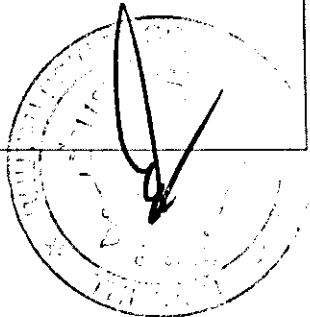

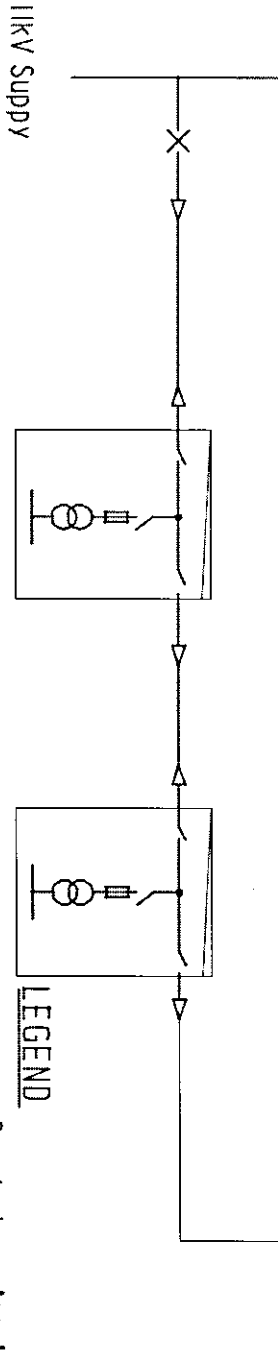
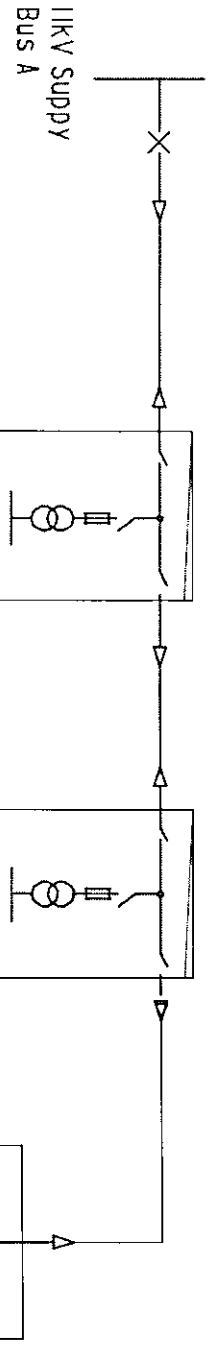

500kVA  
11/0.415kV  
package Substation

Note: For simplicity earth switches not shown.

- LEGEND**
- Supply bus circuit breaker
  - Load break switch - Normally closed
  - Load break switch - Normally open
  - Fuse switch
  - 250kVA 11/0.415 kV transformer
  - 3c 11kV 150mm XLPE insulated cable

|  |                          |   |   |  |                                    |
|--|--------------------------|---|---|--|------------------------------------|
|  |                          | <b>BHUTAN POWER CORPORATION LIMITED</b> |   | <b>ENGINEERING DESIGN &amp; CONTRACTS DEPARTMENT</b> |                                    |
| DESIGNATION<br>DRAFTSPERSON<br>DESIGNER<br>PROJECT MANAGER<br>HEAD OF DEPARTMENT | NAME<br><br><br><br><br> | DATE<br><br><br><br><br>                | ARRANGEMENT FOR UNDERGROUND DISTRIBUTION SYSTEM - RESIDENTIAL | DISTRIBUTION DESIGN & CONSTRUCTION STANDARD          | DRAWING NO. BPC - DDCCS - 2015 - 7 |
|  |                          |   |   | REVISION 2015  |                                    |

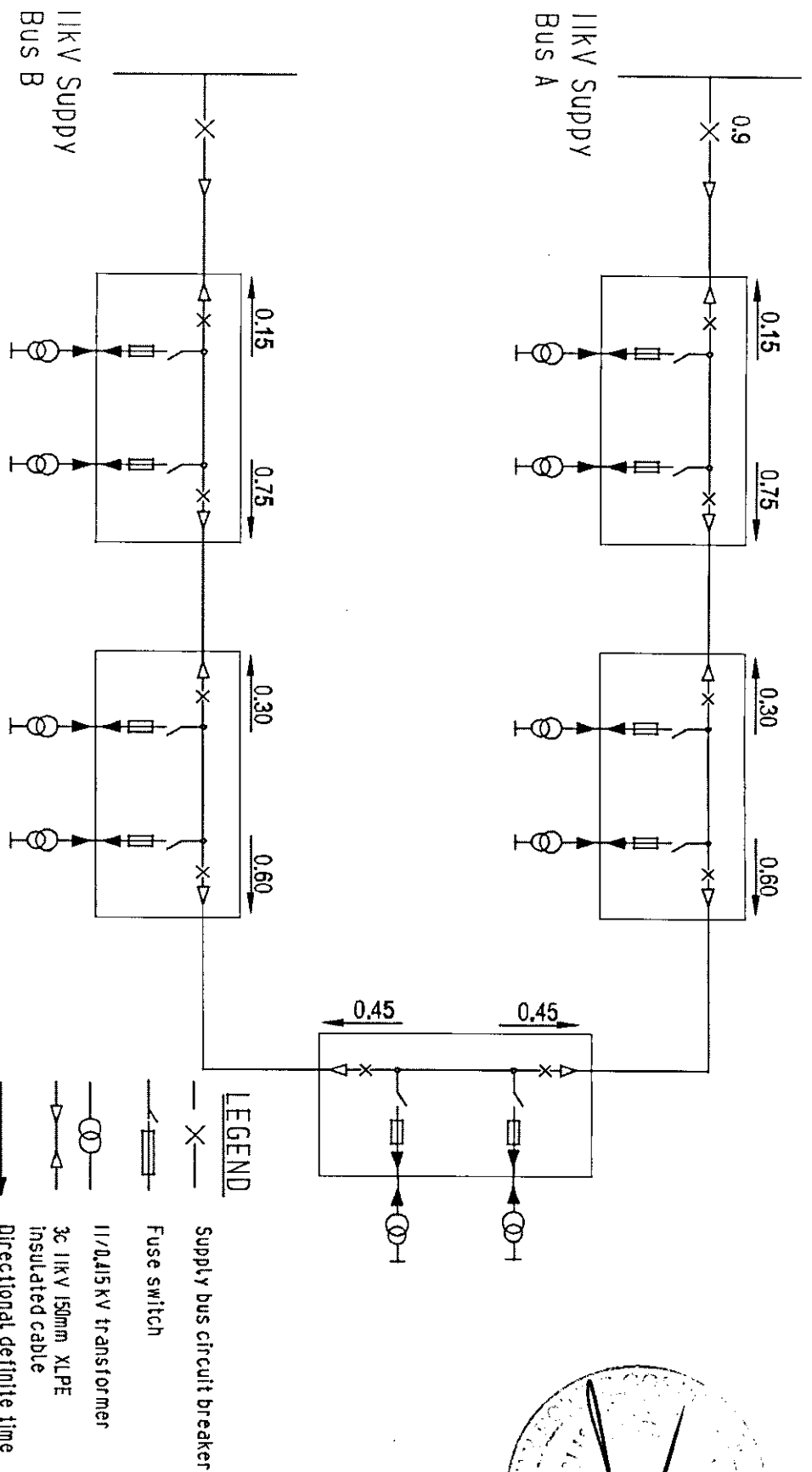

Note: For simplicity earth switches not shown.

|   |      |   |  |  |  |
|---|------|---|--|--|--|
|  |      | <b>BHUTAN POWER CORPORATION LIMITED</b> |  | <b>ENGINEERING DESIGN &amp; CONTRACTS DEPARTMENT</b> |  |
| DESIGNATION   | NAME | DATE                                    | <b>ARRANGEMENT FOR UNDERGROUND DISTRIBUTION SYSTEM-INDUSTRIAL &amp; COMMERCIAL</b> |  |  |
| DRAFTER/PERSON  |      |   | <b>DISTRIBUTION DESIGN &amp; CONSTRUCTION STANDARD</b>                             |  |  |
| DESIGNER  |      |   | <b>DRAWING NO. BPC-DDCS-2015-8</b>   |  |  |
| PROJECT MANAGER   |      |   | <b>REVISION 2015</b>   |  |  |
| HEAD OF DEPARTMENT  |      |   |  |  |  |

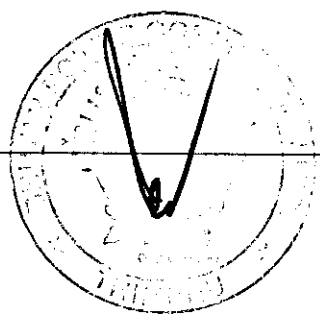

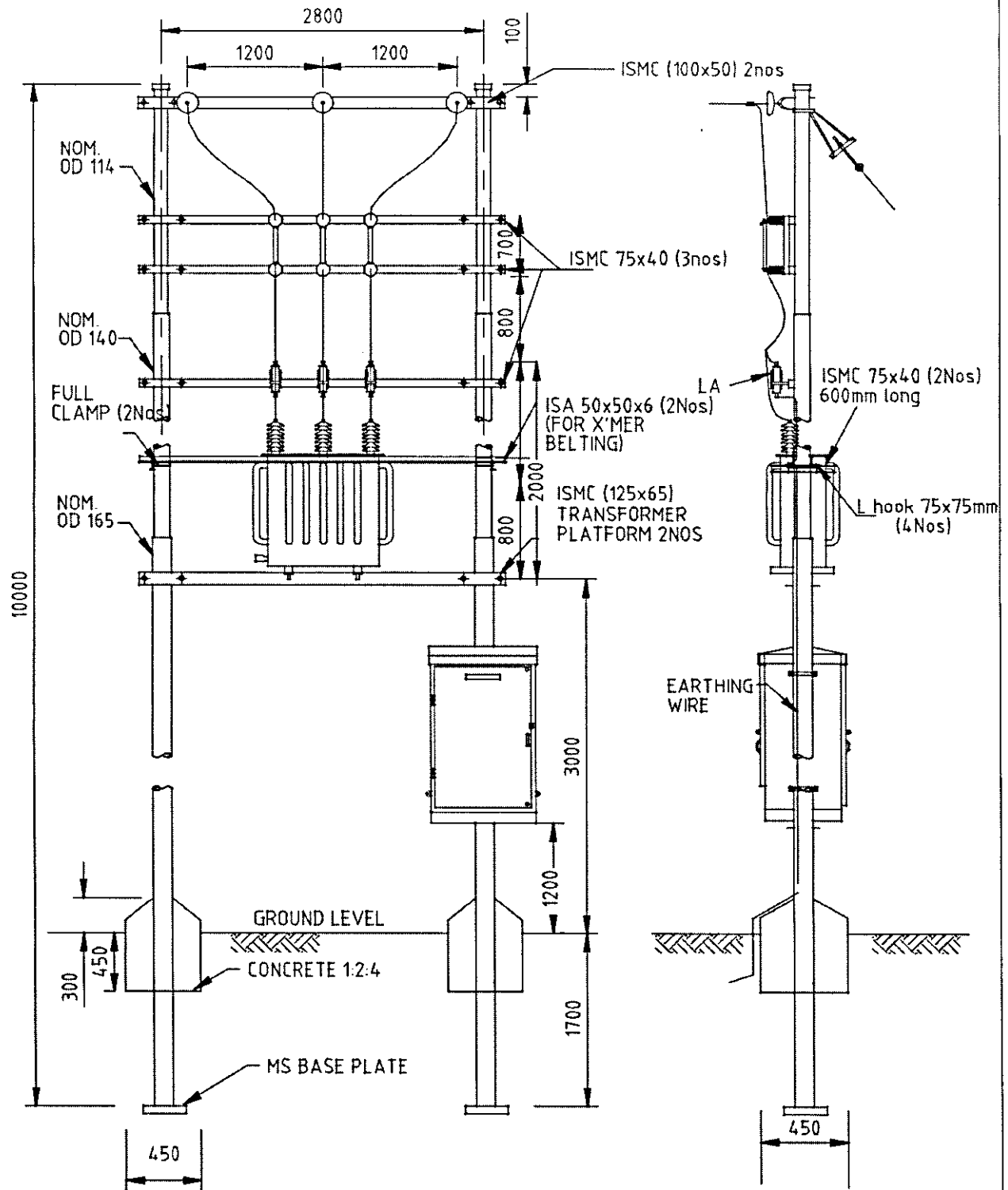

**NOTES**

1. DIMENSIONS AS SHOWN ARE IN mm.
2. MOUNTING HEIGHT OF THE TOP DO FUSE TO BE ADJUSTED WITHIN 6M FOR USE OF HOT STICK

|  |   |                  |
|--|---|------------------|
| <p><b>BHUTAN POWER CORPORATION LIMITED</b></p> | <b>ENGINEERING DESIGN &amp; CONTRACTS DEPARTMENT</b>  |                  |
|  | <b>DISTRIBUTION DESIGN &amp; CONSTRUCTION STANDARD</b><br><b>TERMINATION POLE SUBSTATION TYPE 'A' ARRANGEMENT</b> |                  |
| DESIGNATION                                    | NAME  | DATE             |
| DRAFTSMAN                                      |   |                  |
| DESIGNER                                       |   |                  |
| DESIGN CHECK                                   |   |                  |
| PROJECT MANAGER                                |   |                  |
| PROJECT DIRECTOR                               |   |                  |
| DRAWING NO. BPC-DDCS-2015-8                    |   | REVISION<br>2015 |

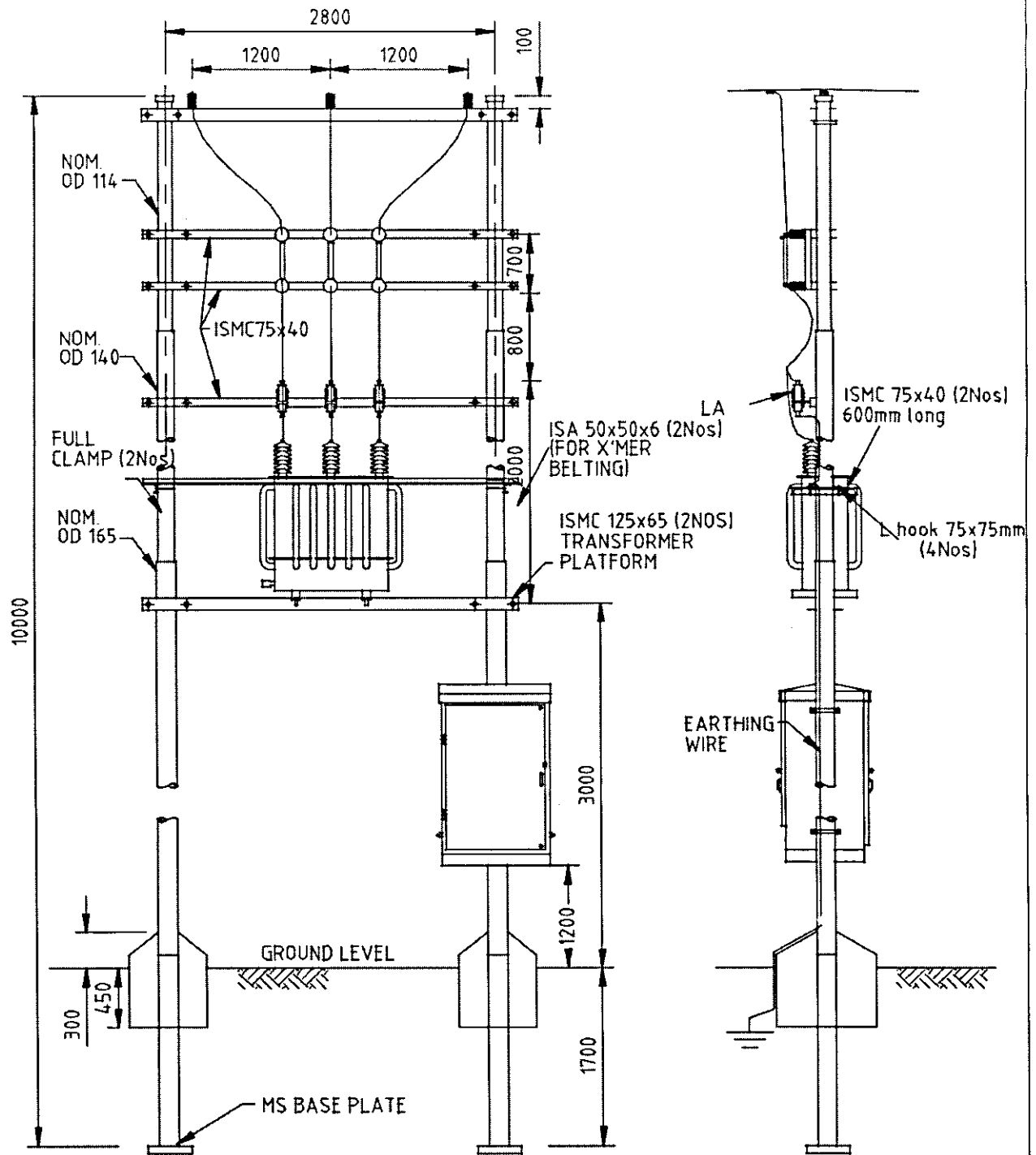

**NOTES**

1. DIMENSIONS AS SHOWN ARE IN mm.
2. MOUNTING HEIGHT OF THE TOP DO FUSE TO BE ADJUSTED WITHIN 6M FOR USE OF HOT STICK

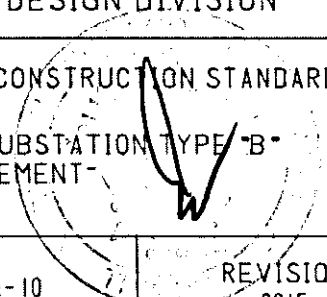
|   |   |  |  |   |  |
|---|---|--|--|---|--|
|  | <b>BHUTAN POWER CORPORATION LIMITED</b> |  | <b>ENGINEERING &amp; DESIGN DIVISION</b>               |   |  |
|   |   |  | <b>DISTRIBUTION DESIGN &amp; CONSTRUCTION STANDARD</b> |   |  |
|   |   | <b>INTERMEDIATE POLE SUBSTATION TYPE "B" ARRANGEMENT</b> |  |  |  |
| DESIGNATION   | NAME                                    | DATE   |  |   |  |
| DRAFTSMAN   |   |  |  |   |  |
| DESIGNER  |   |  |  |   |  |
| DESIGN CHECK  |   |  |  |   |  |
| PROJECT MANAGER   |   |  | DRAWING NO. BPC-DDCS-2015-10                           |   |  |
| PROJECT DIRECTOR  |   |  | REVISION 2015  |   |  |

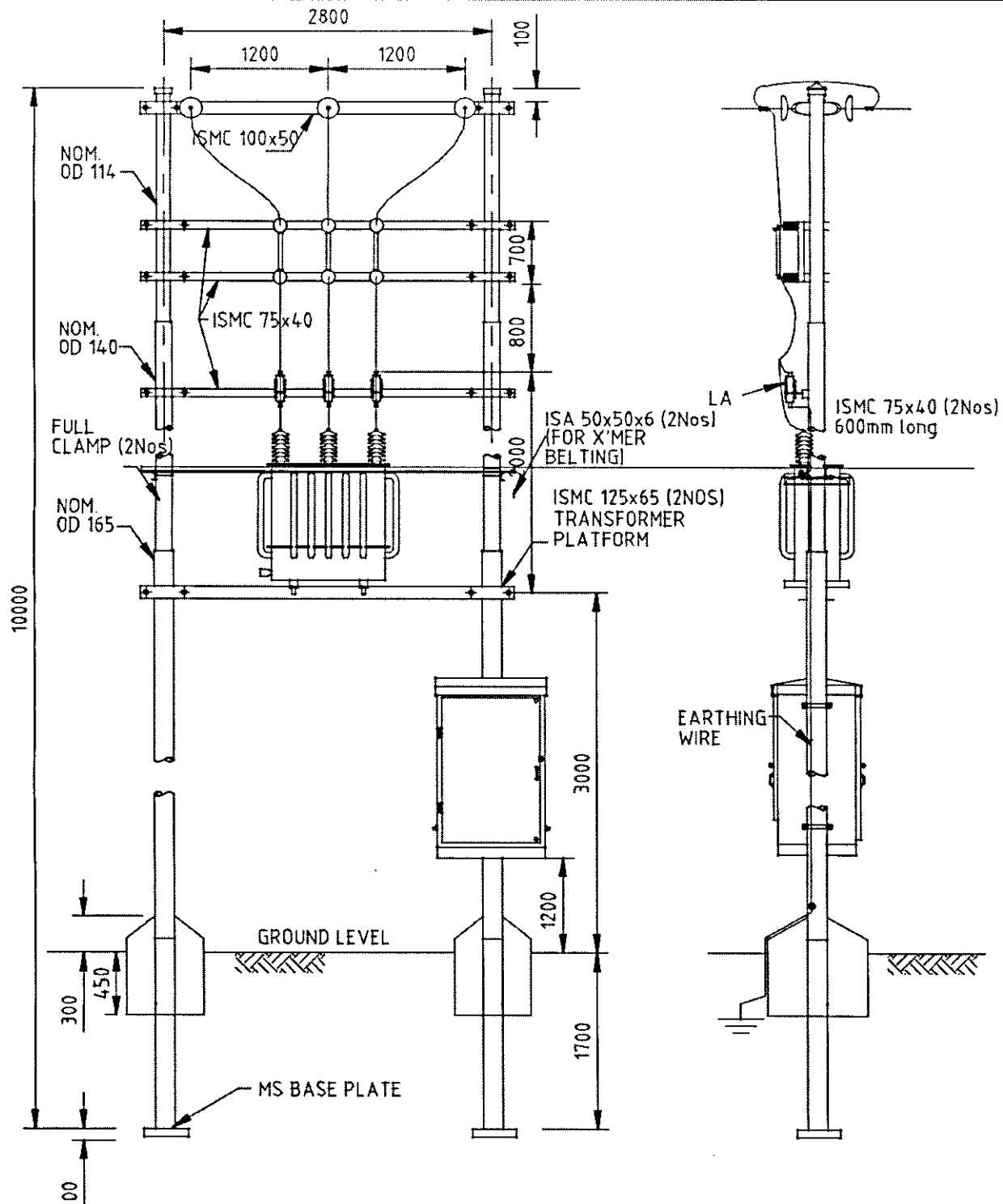

**NOTES**

1. DIMENSIONS AS SHOWN ARE IN mm.
2. MOUNTING HEIGHT OF THE TOP DO FUSE TO BE ADJUSTED WITHIN 6M FOR USE OF HOT STICK

|   |   |      |   |  |
|---|---|------|---|--|
|   | <p align="center"><b>BHUTAN POWER CORPORATION LIMITED</b></p> |      | <p align="center">ENGINEERING DESIGN &amp; CONTRACTS DEPARTMENT</p>   |  |
|   |   |      | <p align="center">DISTRIBUTION DESIGN &amp; CONSTRUCTION STANDARD</p> |  |
| <p align="center">TENSION POLE SUBSTATION TYPE 'C' ARRANGMENT</p> |   |      | <p align="right">REVISION</p>   |  |
| DESIGNATION   | NAME  | DATE | DRAWING NO. BPC -DDCS -2015 -11                                       |  |
| DRAFTSMAN   |   |      | 2015  |  |
| DESIGNER  |   |      |   |  |
| DESIGN CHECK  |   |      |   |  |
| PROJECT MANAGER   |   |      |   |  |
| PROJECT DIRECTOR  |   |      |   |  |

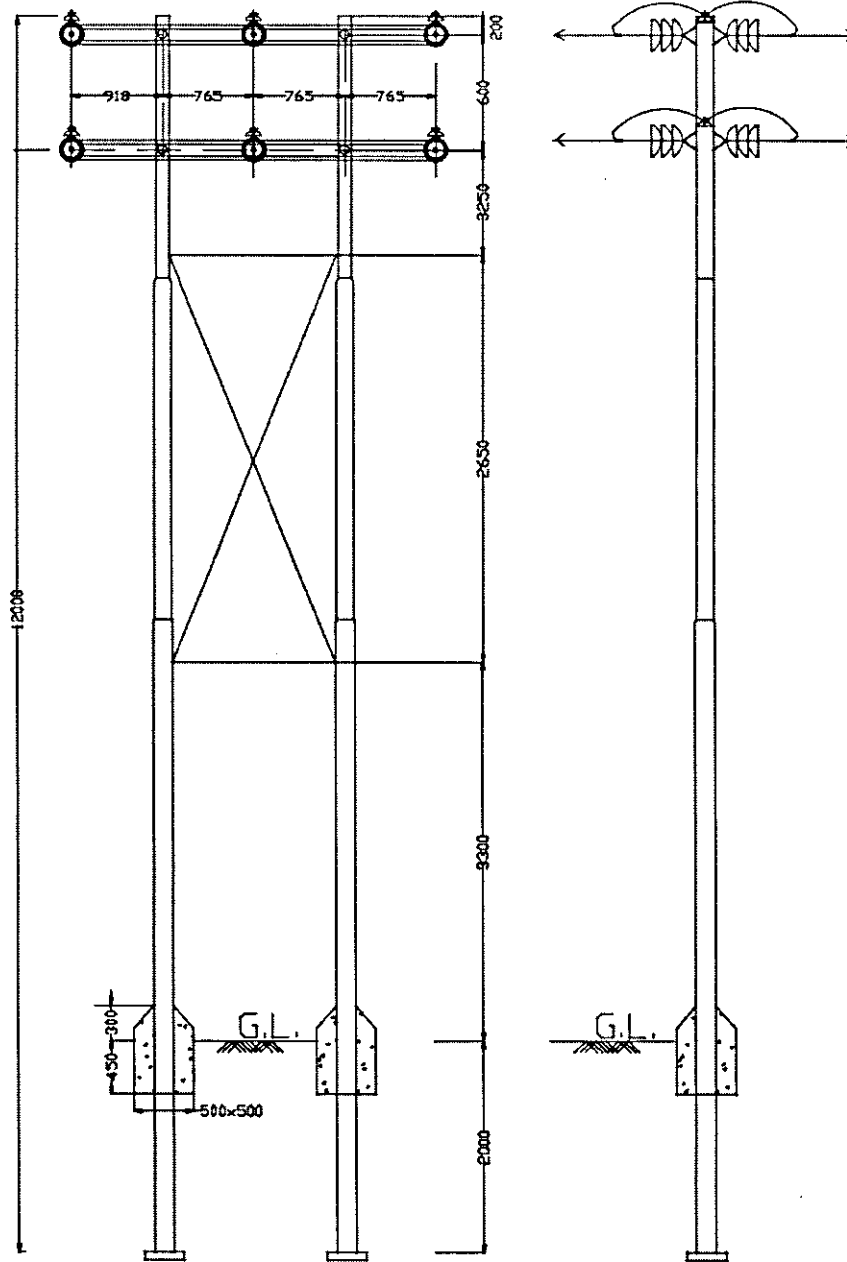

BHUTAN POWER CORPORATION LIMITED

ENGINEERING DESIGN & CONTRACTS DEPARTMENT

DISTRIBUTION DESIGN & CONSTRUCTION STANDARD

11 KV, D - CKT, POLE STRUCTURE (HORIZONTAL CONFIGURATION)

| DESIGNATION      | NAME | DATE |
|------------------|------|------|
| DRAFTSMAN        |      |      |
| DESIGNER         |      |      |
| DESIGN CHECK     |      |      |
| PROJECT MANAGER  |      |      |
| PROJECT DIRECTOR |      |      |

DRAWING NO. BPC-DCCS-2015-12/A

REVISION  
2015

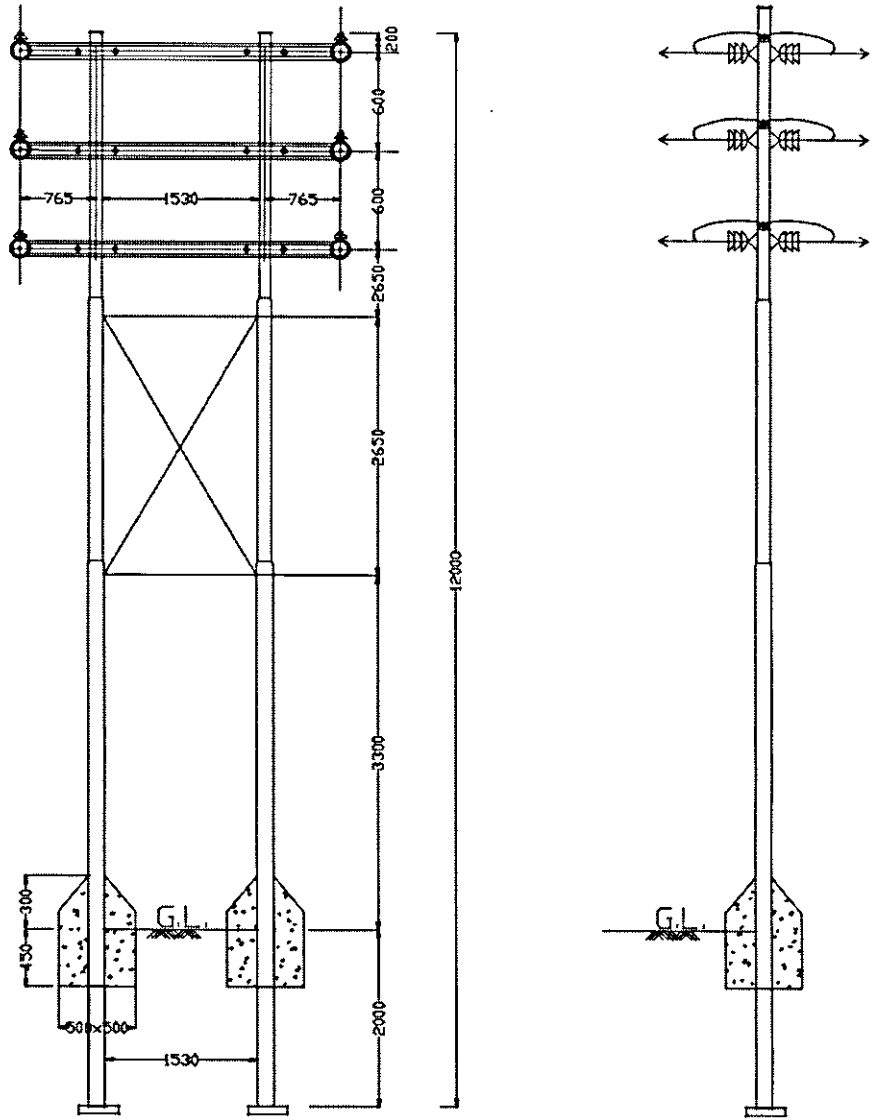

BHUTAN POWER CORPORATION LIMITED

ENGINEERING DESIGN & CONTRACTS DEPARTMENT

DISTRIBUTION DESIGN & CONSTRUCTION STANDARD

11 KV, D - CKT, POLE STRUCTURE (VERTICAL CONFIGURATION)

| DESIGNATION      | NAME | DATE |
|------------------|------|------|
| DRAFTSMAN        |      |      |
| DESIGNER         |      |      |
| DESIGN CHECK     |      |      |
| PROJECT MANAGER  |      |      |
| PROJECT DIRECTOR |      |      |

DRAWING NO. BPC-DDCS-2015-12/B

REVISION  
2015



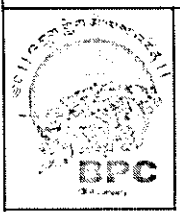
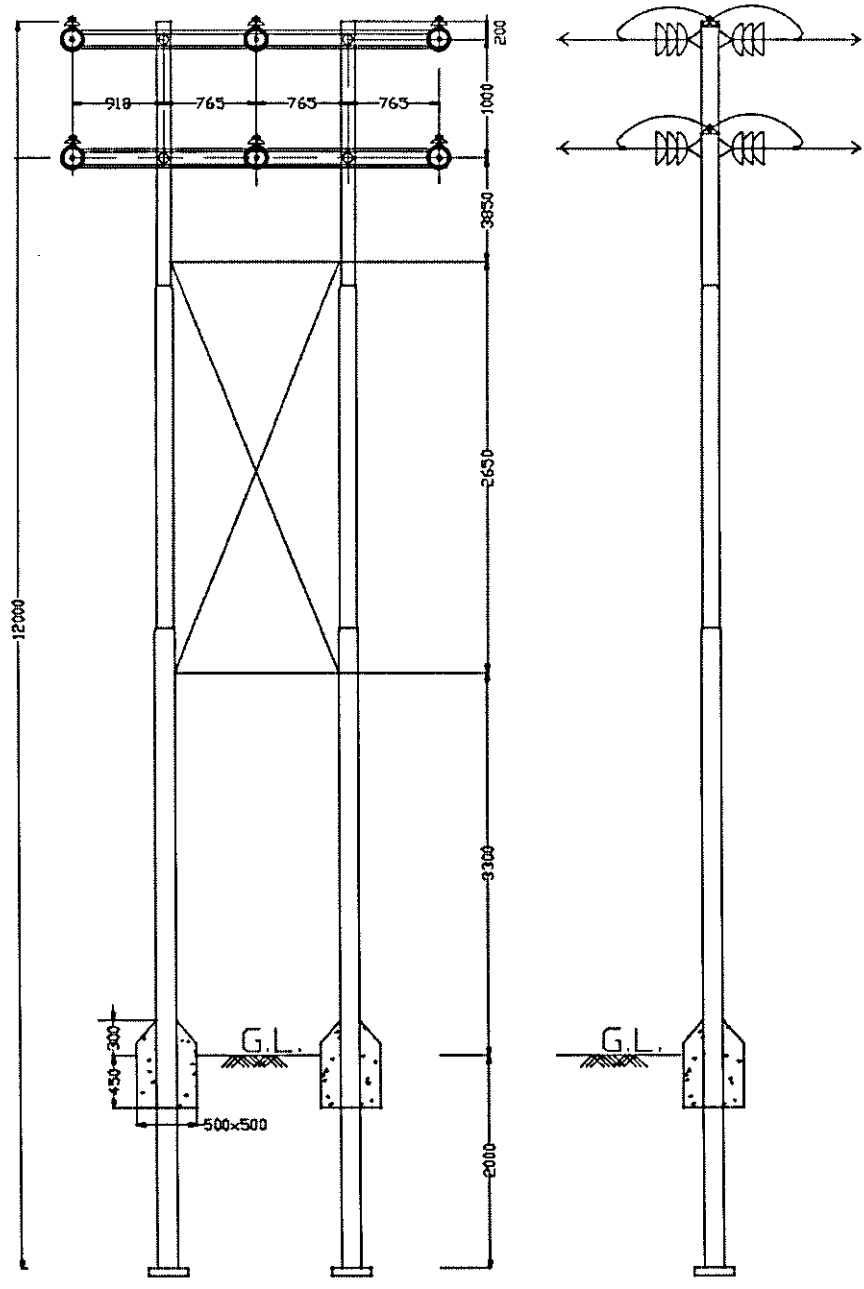

BHUTAN POWER CORPORATION LIMITED

ENGINEERING DESIGN & CONTRACTS DEPARTMENT

DISTRIBUTION DESIGN & CONSTRUCTION STANDARD

33 kV, D - CKT, POLE STRUCTURE (HORIZONTAL CONFIGURATION)

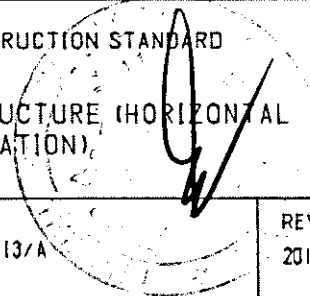

| DESIGNATION      | NAME | DATE |
|------------------|------|------|
| DRAFTSMAN        |      |      |
| DESIGNER         |      |      |
| DESIGN CHECK     |      |      |
| PROJECT MANAGER  |      |      |
| PROJECT DIRECTOR |      |      |

DRAWING NO. BPC-DDCS-2015-13/A

REVISION  
2015

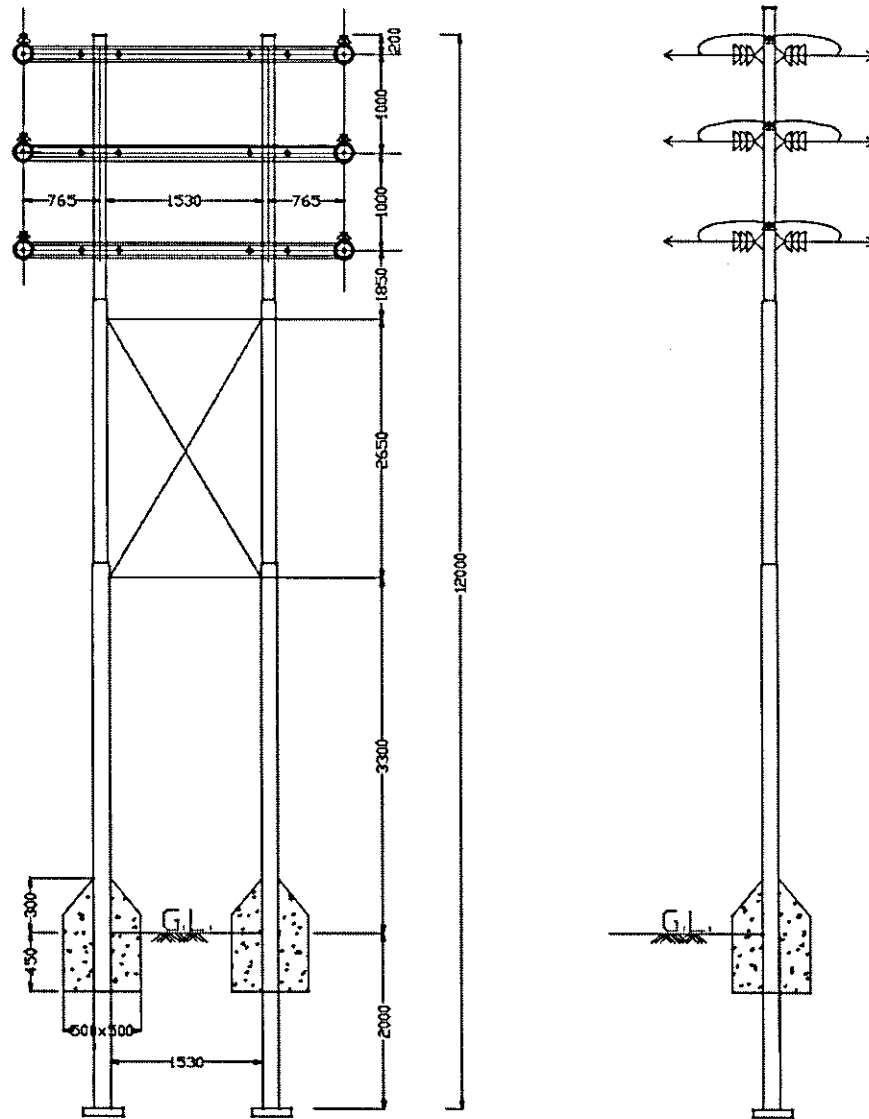

BHUTAN POWER CORPORATION LIMITED

ENGINEERING DESIGN & CONTRACTS DEPARTMENT

DISTRIBUTION DESIGN & CONSTRUCTION STANDARD

33 kV, D - CKT, POLE STRUCTURE (VERTICAL CONFIGURATION)

| DESIGNATION      | NAME | DATE |
|------------------|------|------|
| DRAFTSMAN        |      |      |
| DESIGNER         |      |      |
| DESIGN CHECK     |      |      |
| PROJECT MANAGER  |      |      |
| PROJECT DIRECTOR |      |      |

DRAWING NO. BPC-DDCS-2015-13/B

REVISION  
2015

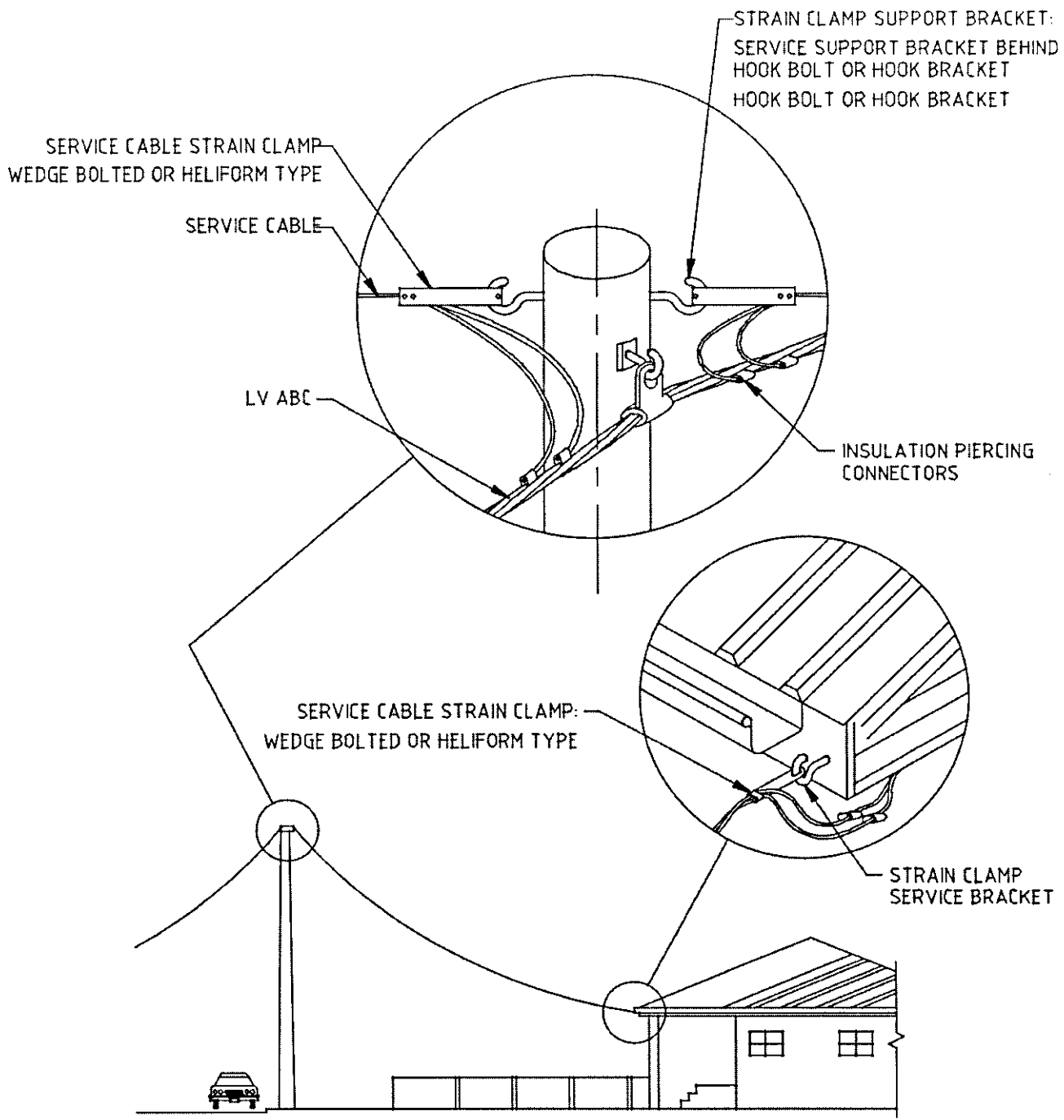

**NOTES**

- 1. DIMENSIONS AS SHOWN ARE IN mm.
- 2. DRAWING IS NOT TO SCALE.

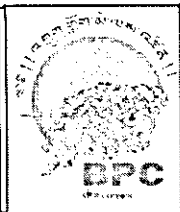

**BHUTAN POWER CORPORATION LIMITED**

**ENGINEERING DESIGN & CONTRACTS DEPARTMENT**

**DISTRIBUTION DESIGN AND CONSTRUCTION STANDARDS**

**LV ABC TYPICAL SERVICE LAYOUT ARRANGEMENT**

| DESIGNATION      | NAME | DATE |
|------------------|------|------|
| DRAFTSMAN        |      |      |
| DESIGNER         |      |      |
| DESIGN CHECK     |      |      |
| PROJECT MANAGER  |      |      |
| PROJECT DIRECTOR |      |      |

DRAWING NO. BPC - DDCS - 2015-14

REVISION  
2015

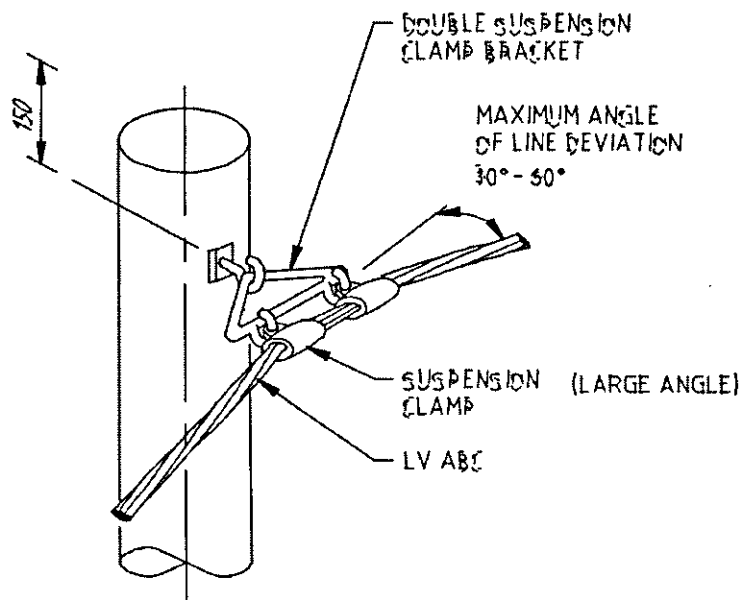
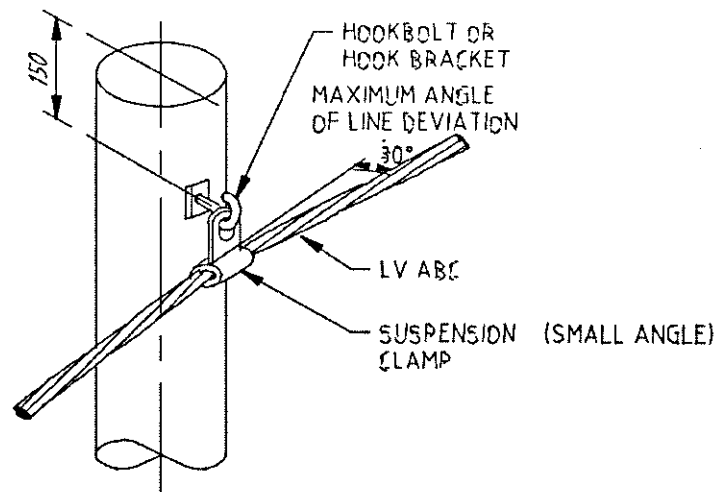

**NOTES**

1. DIMENSIONS AS SHOWN ARE IN mm.
2. DRAWING IS NOT TO SCALE.



**BHUTAN POWER CORPORATION LIMITED**

**ENGINEERING DESIGN & CONTRACTS DEPARTMENT**

**DISTRIBUTION DESIGN & CONSTRUCTION STANDARD**

**LV ABC  
INTERMEDIATE & ANGLE POLES DETAILS**

| DESIGNATION      | NAME | DATE |
|------------------|------|------|
| DRAFTSMAN        |      |      |
| DESIGNER         |      |      |
| DESIGN CHECK     |      |      |
| PROJECT MANAGER  |      |      |
| PROJECT DIRECTOR |      |      |

DRAWING NO. BPC-DDCS-2015-15

*[Signature]*  
2015

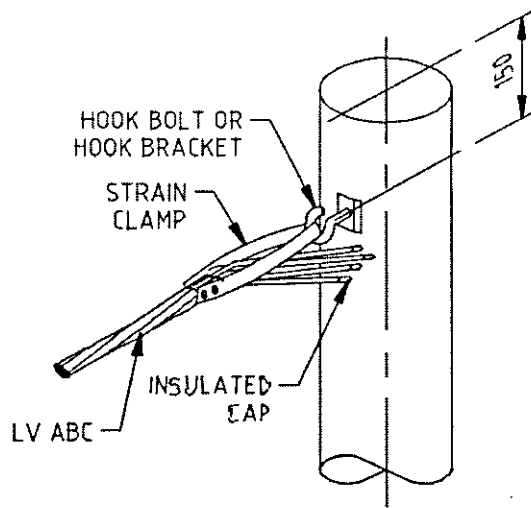

ALLOW SUFFICIENT CABLE TAIL  
TO ALLOW FOR FUTURE EXTENSION

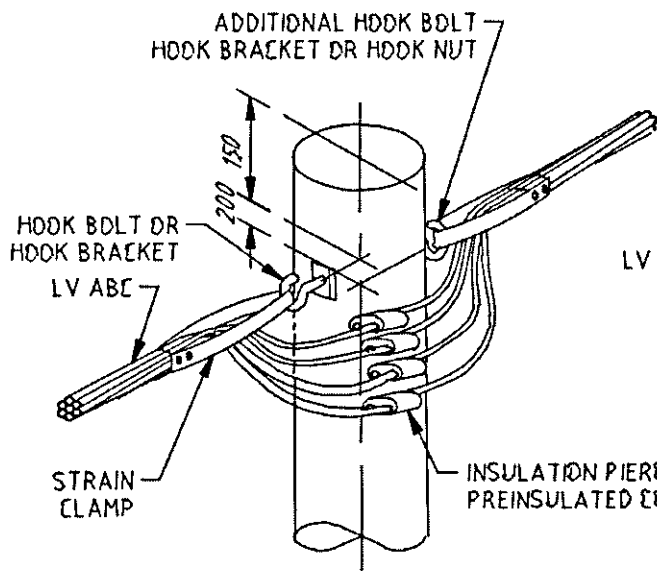

FIELD CONDITIONS MAY ALLOW  
CABLE TO BE CONTINUOUS AT POLE

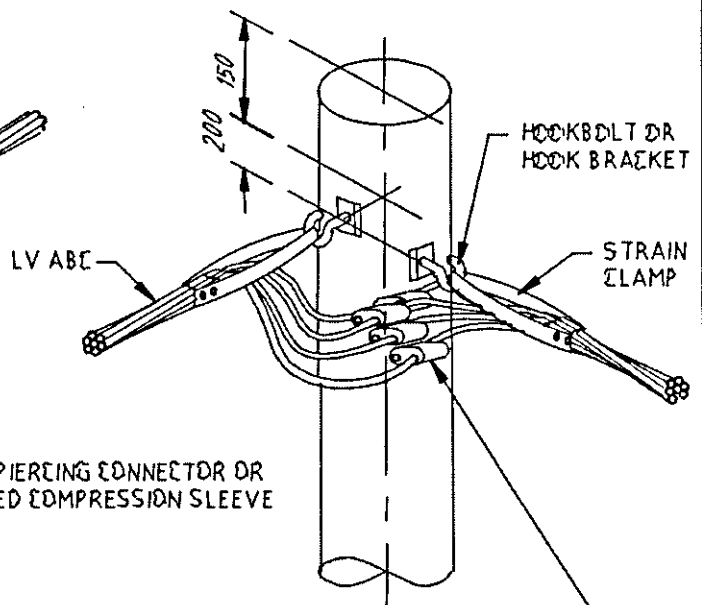

INSULATION PIERCING CONNECTOR DR  
PREINSULATED COMPRESSION SLEEVE

NOTES

1. DIMENSIONS AS SHOWN ARE IN mm.
2. DRAWING IS NOT TO SCALE.



BHUTAN POWER CORPORATION LIMITED

ENGINEERING DESIGN & CONTRACTS DEPARTMENT

TITLE : DISTRIBUTION DESIGN & CONSTRUCTION STANDARD  
LV ABC TERMINATION & ANCHOR POLES DETAILS

| DESIGNATION        | NAME | DATE |
|--------------------|------|------|
| DRAFTSPERSON       |      |      |
| DESIGNER           |      |      |
| PROJECT MANAGER    |      |      |
| HEAD OF DEPARTMENT |      |      |

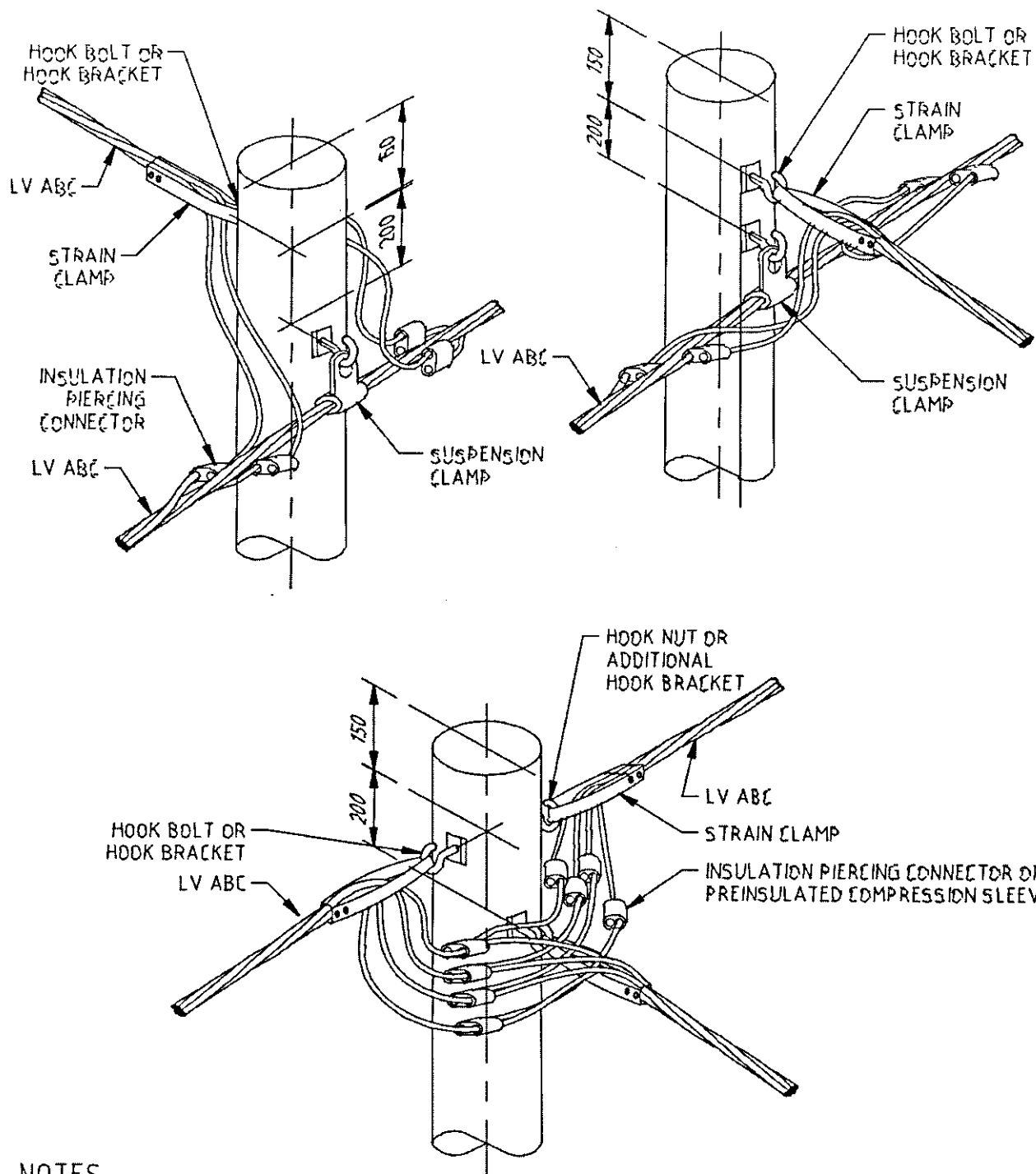

DRAWING NO. BPC - DDCS - 2015-16

REV  
2015



**NOTES**

1. DIMENSIONS AS SHOWN ARE IN mm.
2. DRAWING IS NOT TO SCALE.

|   |  |      |   |  |
|---|--|------|---|--|
| <br><b>BPC</b> | <b>BHUTAN POWER CORPORATION LIMITED</b>  |      | <b>ENGINEERING DESIGN &amp; CONTRACTS DEPARTMENT</b>                                  |  |
|   | <b>DISTRIBUTION DESIGN &amp; CONSTRUCTION STANDARD</b><br><b>LV ABC TEE POLE DETAILS</b> |      | <b>DRAWING NO. BPC - DDCS - 2015-17</b>   |  |
| DESIGNATION   | NAME   | DATE |  |  |
| DRAFTSPERSON  |  |      |   |  |
| DESIGNER  |  |      |   |  |
| PROJECT MANAGER   |  |      |   |  |
| HEAD OF DEPARTMENT  |  |      | <b>REVISION</b><br><small>2015</small>  |  |

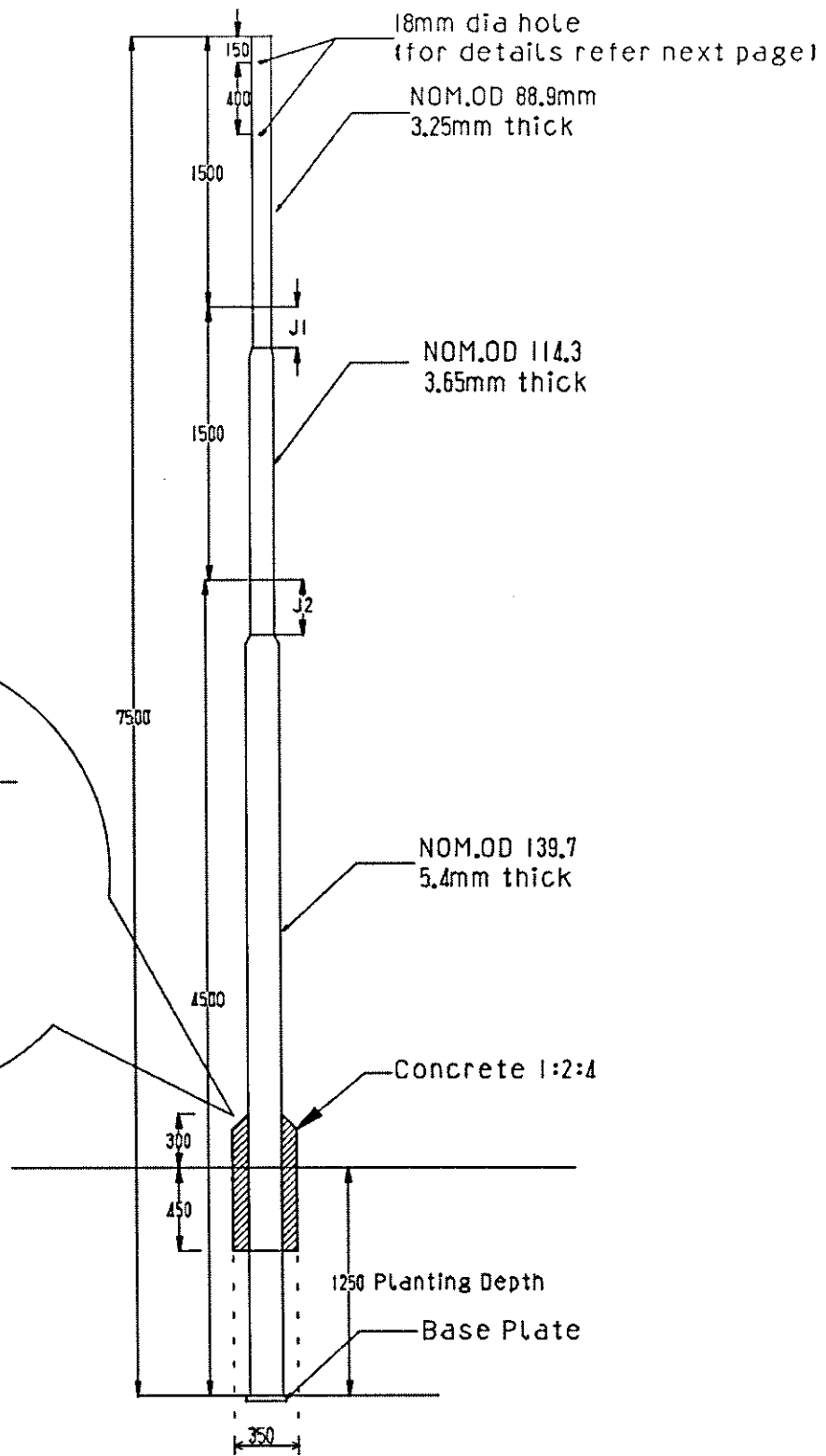

**NOTES**

1. DIMENSIONS AS SHOWN ARE IN MM.
2. SPECIFICATIONS AS PER IS:2713 (PART I TO III : 1980)
3. POLE TOP CAP -M.S. PLATE WOULD BE TAG WELDED TO THE POLE



**BHUTAN POWER CORPORATION LIMITED**

**ENGINEERING DESIGN & CONTRACTS DEPARTMENT**

**DISTRIBUTION DESIGN & CONSTRUCTION STANDARD**

**7.5 METERS SWAGED POLE ASSEMBLY**

|             | NAME | DATE |
|-------------|------|------|
| DESIGNED BY |      |      |
| CHECKED BY  |      |      |
| APPROVED BY |      |      |

DRAWING NO. BPC-DDCS-2015-18

REVISION  
2015

NOM. OD 88.9mm

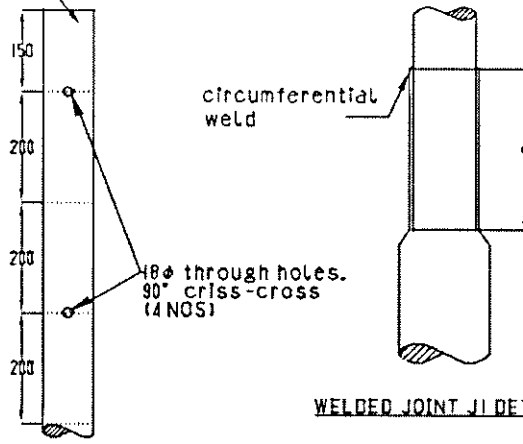

POLE TOP DETAILS

WELDED JOINT J1 DETAILS

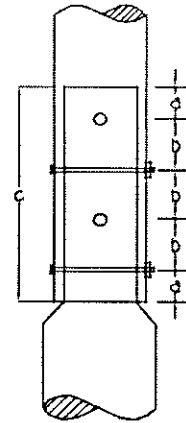

BOLTED JOINT J2 DETAILS

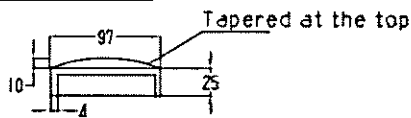

POLE CAP DETAILS (WELDED TO THE POLE)

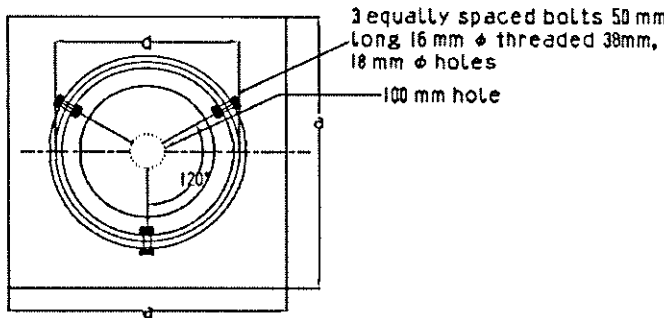
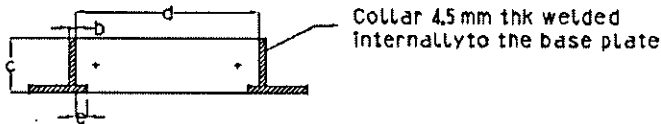

DETAILS OF MS BASE PLATE (Separately packed)

NOTES

1. DIMENSIONS AS SHOWN ARE IN MM.
2. DRAWING NOT TO SCALE.
3. SPECIFICATIONS AS PER IS:2713 (PART I TO III) : 1980)
4. POLE TOP CAP -M.S. PLATE WOULD BE TAG WELDED TO THE POLE

|                    |      |    |
|--------------------|------|----|
| Top Segment        | ..   | .. |
| Middle Segment     | ..   | .. |
| Bottom Segment     | ..   | .. |
| Joint J1           | e .. | .. |
| Joint J2           | f    | .. |
| Base plate details |      | .. |

|   |                                  |                                |   |               |
|---|----------------------------------|--------------------------------|---|---------------|
|  | BHUTAN POWER CORPORATION LIMITED |                                | ENGINEERING DESIGN & CONTRACTS DEPARTMENT   |               |
|   |                                  |                                | DISTRIBUTION DESIGN & CONSTRUCTION STANDARD |               |
|   |                                  | 7.5 METERS SWAGED POLE DETAILS |   |               |
| DESIGNED BY   | NAME                             | DATE                           | DRAWING NO. BPC-DGCS-2015-19                | REVISION 2015 |
| CHECKED BY  |                                  |                                |   |               |
| APPROVED BY   |                                  |                                |   |               |



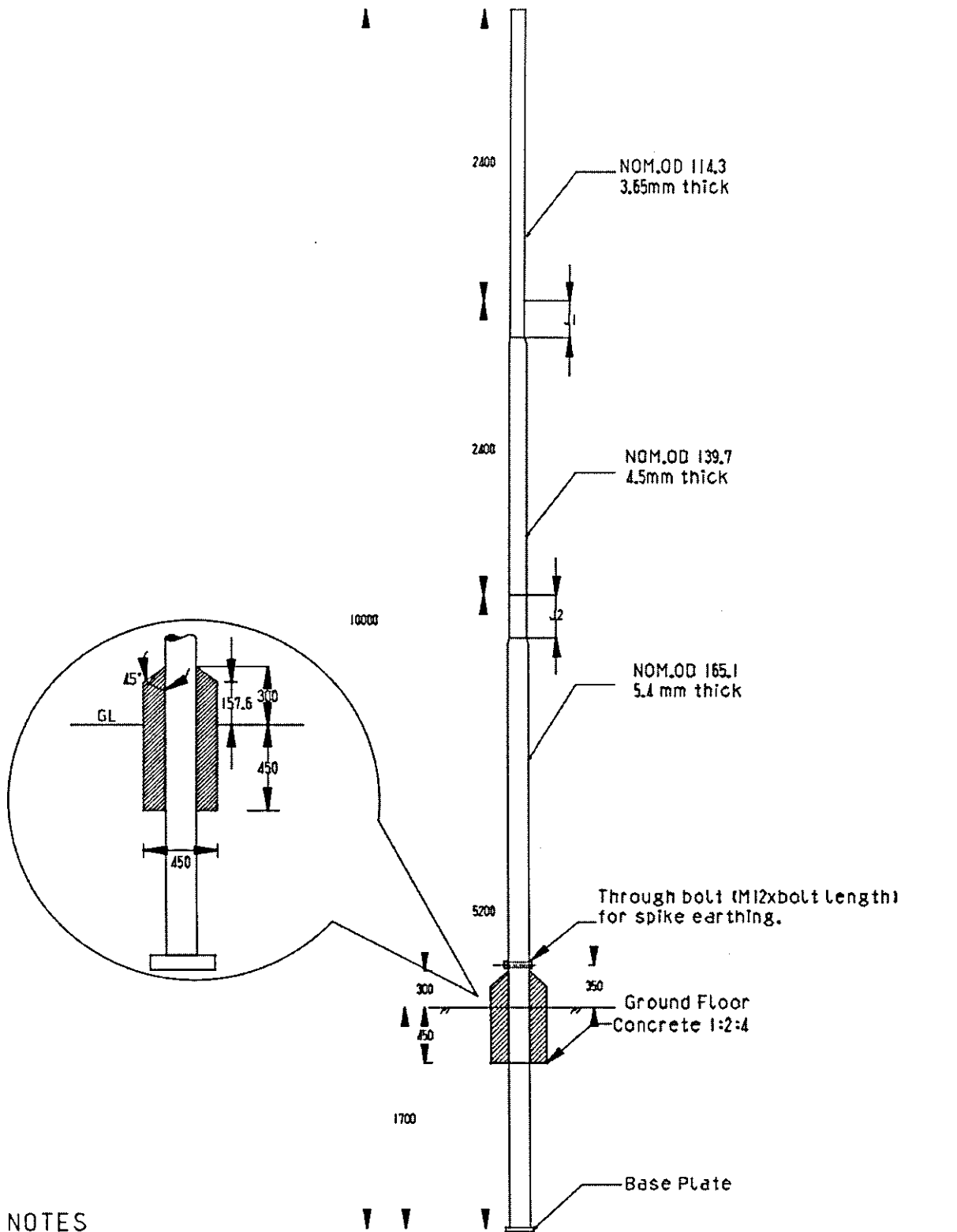

**NOTES**

1. DIMENSIONS AS SHOWN ARE IN MM.
2. SPECIFICATIONS AS PER IS:2713 (PART I TO III) : 1980)
3. POLE TOP CAP -M.S. PLATE WOULD BE TAG WELDED TO THE POLE



BHUTAN POWER CORPORATION LIMITED

ENGINEERING DESIGN & CONTRACTS DEPARTMENT

DISTRIBUTION DESIGN & CONSTRUCTION STANDARD

10 METER SWAGED POLE ASSEMBLY

| DESIGNED BY | NAME | DATE |
|-------------|------|------|
| CHECKED BY  |      |      |
| APPROVED BY |      |      |

DRAWING NO. BPC-DDCS-2015-20

REVISION 2015

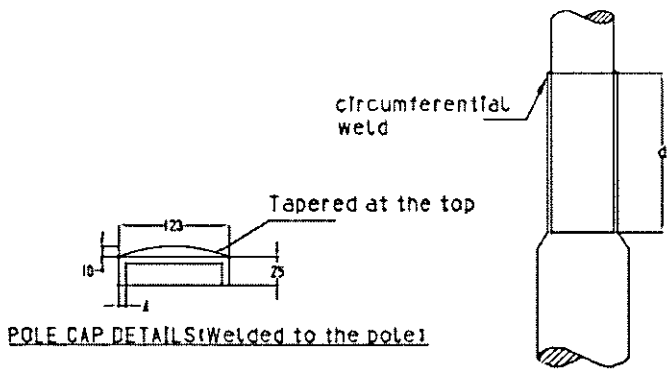

POLE CAP DETAILS (Welded to the pole)

WELDED JOINT J1 DETAILS

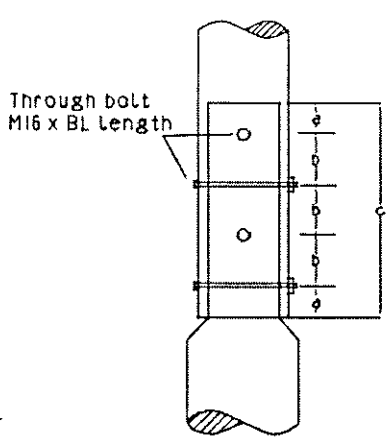

BOLTED JOINT J2 DETAILS

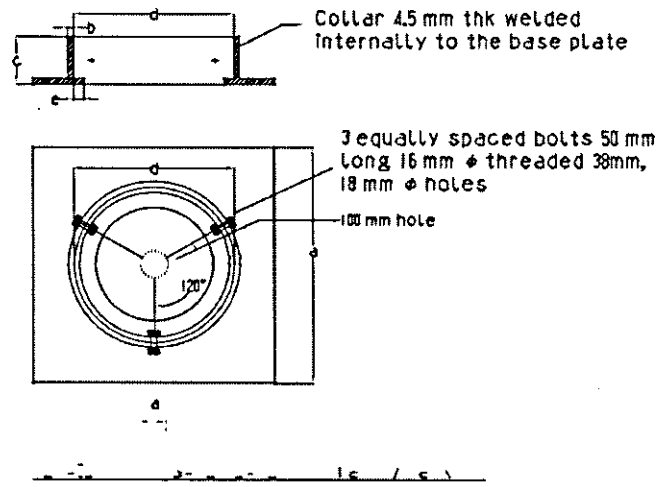

| Pole Type      |              | 10 M<br>(410-SP-45) |
|----------------|--------------|---------------------|
| Top Segment    | Length       | mm 18000            |
|                | OD           | mm 114.3            |
|                | Thickness    | mm 3.55             |
| Middle Segment | Length       | mm 2400             |
|                | OD           | mm 129.7            |
|                | Thickness    | mm 4.5              |
| Bottom Segment | Length       | mm 2400             |
|                | OD           | mm 165.1            |
|                | Thickness    | mm 5.1              |
| Int J1         | Welded Joint |                     |
|                |              | mm 300              |
| In J2          |              | mm 55               |
|                |              | mm 80               |
|                |              | mm 250              |
|                | BL           | mm 190              |
| Planting Depth |              | mm 1700             |
| Base plate     |              | mm 250              |
|                |              | mm 6                |
|                |              | mm 70               |
|                |              | mm 165.1            |
|                |              | mm 18               |

- 3. SPECIFICATIONS AS PER IS:2713 (PART I TO III) : 1980)
- 4. POLE TOP CAP -M.S. PLATE WOULD BE TAG WELDED TO THE POLE

|   |   |                                     |  |  |  |
|---|---|-------------------------------------|--|--|--|
|  | <b>BHUTAN POWER CORPORATION LIMITED</b> |                                     | <b>ENGINEERING DESIGN &amp; CONTRACTS DEPARTMENT</b>   |  |  |
|   |   |                                     | <b>DISTRIBUTION DESIGN &amp; CONSTRUCTION STANDARD</b> |  |  |
|   |   | <b>10 METER SWAGED POLE DETAILS</b> |  |  |  |
| DESIGNED BY   | NAME                                    | DATE                                | DRAWING NO. BPC-DDCS-2015-21                           |  |  |
| CHECKED BY  |   |                                     |  |  |  |
| APPROVED BY   |   |                                     |  |  |  |
|   |   |                                     | REVISION 2015  |  |  |

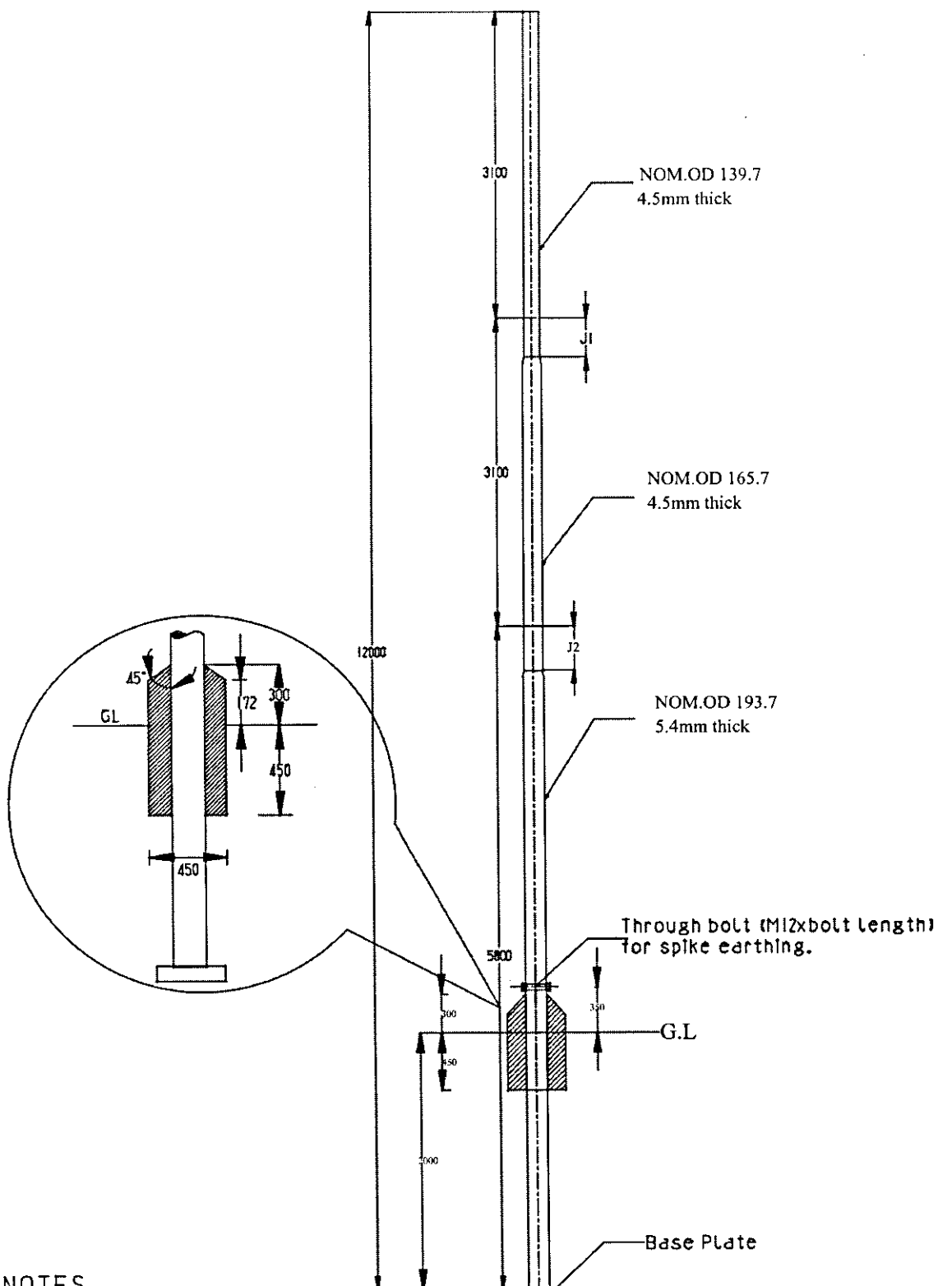

**NOTES**

- 1. DIMENSIONS AS SHOWN ARE IN MM .
- 2. SPECIFICATIONS AS PER IS:2713 (PART I TO III : 1980)
- 3. POLE TOP CAP -M.S. PLATE WOULD BE TAG WELDED TO THE POLE

|   |   |      |  |  |
|---|---|------|--|--|
|  | <b>BHUTAN POWER CORPORATION LIMITED</b> |      | <b>ENGINEERING DESIGN &amp; CONTRACTS DEPARTMENT</b> |  |
|   |   |      | <b>DISTRIBUTION DESIGN AND CONSTRUCTION STANDARD</b> |  |
|   |   |      | <b>12 METERS SWAGED POLE ASSEMBLY</b>                |  |
| DESIGNED BY   | NAME                                    | DATE | DRAWING NO. BPC-DDCS-2015-22                         |  |
| CHECKED BY  |   |      |  |  |
| APPROVED BY   |   |      |  |  |
|   |   |      | REVISION<br>2015                                     |  |

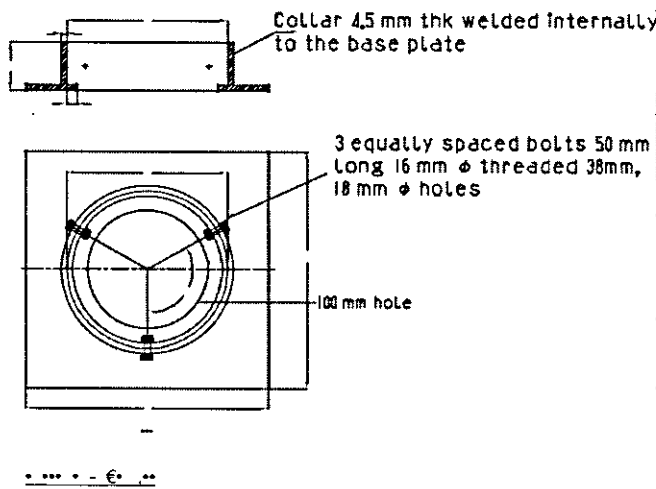
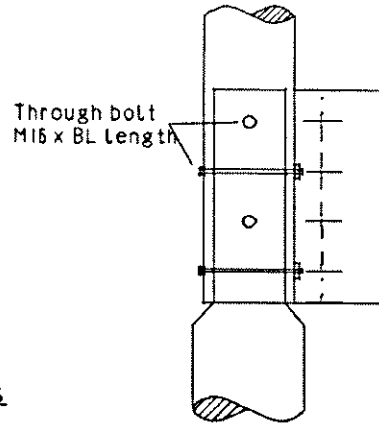
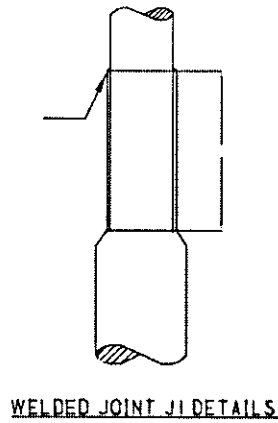
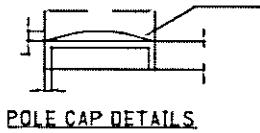

| Pole Type             |              | 12 M (110-SP-B2) |       |
|-----------------------|--------------|------------------|-------|
| Top Segment           | Length       | mm               | 12000 |
|                       | OD           | mm               | 138,7 |
|                       | Thickness    | mm               | 4,5   |
| Middle Segment        | Length       | mm               | 3100  |
|                       | OD           | mm               | 165,7 |
|                       | Thickness    | mm               | 4,5   |
| Bottom Segment        | Length       | mm               | 3100  |
|                       | OD           | mm               | 193,7 |
|                       | Thickness    | mm               | 5,4   |
| Joint J1              | Welded Joint |                  |       |
|                       | d            | mm               | 300   |
| Joint J2              | a            | mm               | 55    |
|                       | b            | mm               | 80    |
|                       | c            | mm               | 350   |
|                       | BL           | mm               | 180   |
| Planting Depth        |              | mm               | 2000  |
| Base plate details    | a            | mm               | 250   |
|                       | b            | mm               | 5     |
|                       | c            | mm               | 50    |
|                       | d            | mm               | 193,7 |
|                       | e            | mm               | 10    |
| BL for spike earthing |              | mm               | 210   |

**NOTES**

1. DIMENSIONS AS SHOWN ARE IN MM.
2. DRAWING NOT TO SCALE
3. SPECIFICATIONS AS PER IS-2713 (PART I TO III : 1980)
4. POLE TOP CAP -M.S. PLATE WOULD BE TAG WELDED TO THE POLE

|   |   |  |   |  |
|---|---|--|---|--|
|  | <b>BHUTAN POWER CORPORATION LIMITED</b> |  | ENGINEERING DESIGN & CONTRACTS DEPARTMENT     |  |
|   |   |  | DISTRIBUTION DESIGN AND CONSTRUCTION STANDARD |  |
| DESIGNED BY _____ NAME _____ DATE _____<br>CHECKED BY _____<br>APPROVED BY _____    |   |  | <b>12 METERS SWAGED POLE ASSEMBLY DETAILS</b> |  |
|   |   |  | DRAWING NO. BPC-DDCS-2015-23                  |  |
|   |   |  | REVISION<br>2015                              |  |

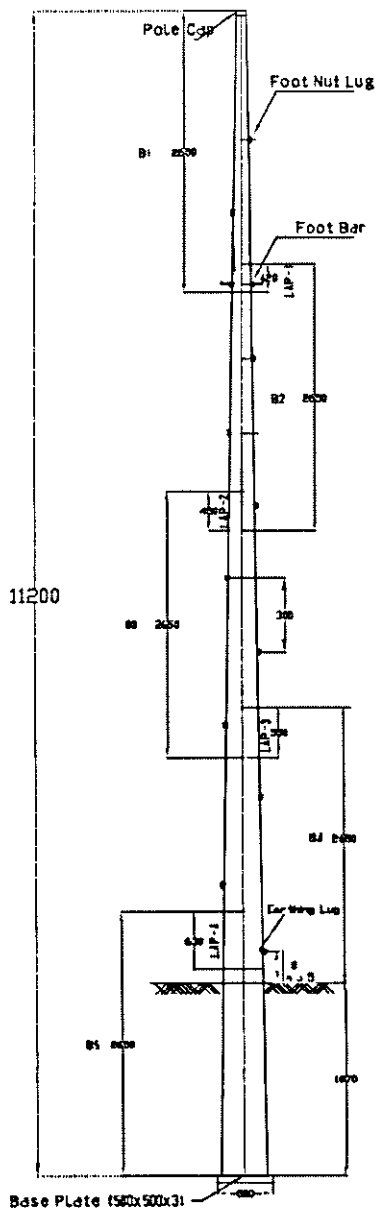

| PARAMETERS          |      |      |      |      |      |
|---------------------|------|------|------|------|------|
| SECTION             | B1   | B2   | B3   | B4   | B5   |
| LENGTH(mm)          | 2650 | 2650 | 2650 | 2650 | 2650 |
| THICKNESS(mm)       | 2.1  | 2.1  | 2.1  | 2.1  | 2.1  |
| TOP DIAMETER(mm)    | 119  | 180  | 240  | 298  | 352  |
| BOTTOM DIAMETER(mm) | 197  | 258  | 318  | 375  | 430  |

| OVERLAPS |                |                |                |                |
|----------|----------------|----------------|----------------|----------------|
| OVERLAPS | LAP-1<br>B1/B2 | LAP-2<br>B2/B3 | LAP-3<br>B3/B4 | LAP-4<br>B4/B5 |
| OVERLAPS | 420            | 450            | 550            | 630            |

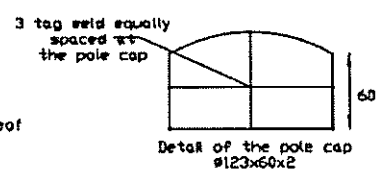
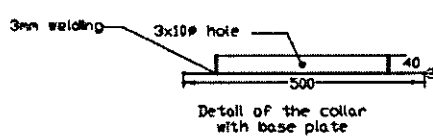
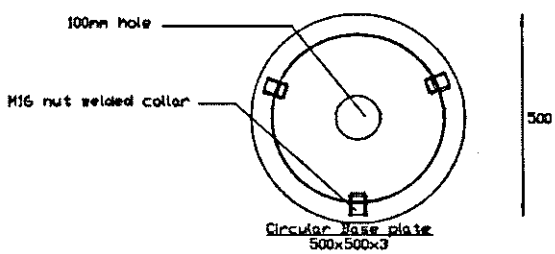
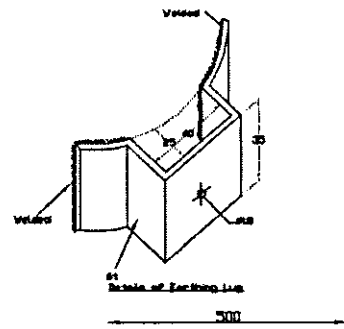

Note:  
 \*ALL Parts shall be BS 4360: 1996 Grade 50 C and Galvanization as per IS 2629-1985 or BS 729-1971 or Equivalent National or International Standards and any revision thereof  
 \*ALL Dimensions in mm  
 \*Footing bar distance to be maintained at 380mm

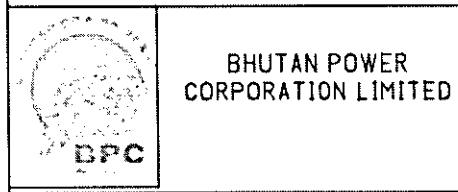

BHUTAN POWER CORPORATION LIMITED

ENGINEERING DESIGN & CONTRACTS DEPARTMENT

TITLE : DISTRIBUTION DESIGN & CONSTRUCTION STANDARD

TELESCOPIC POLE DETAILS FOR 11.2M

| DESIGNATION      | NAME | DATE |
|------------------|------|------|
| DRAFTSMAN        |      |      |
| DESIGNER         |      |      |
| DESIGN CHECK     |      |      |
| PROJECT MANAGER  |      |      |
| PROJECT DIRECTOR |      |      |

DRAWING NO. BPC-DDCS-2015-24

REVISION  
2015

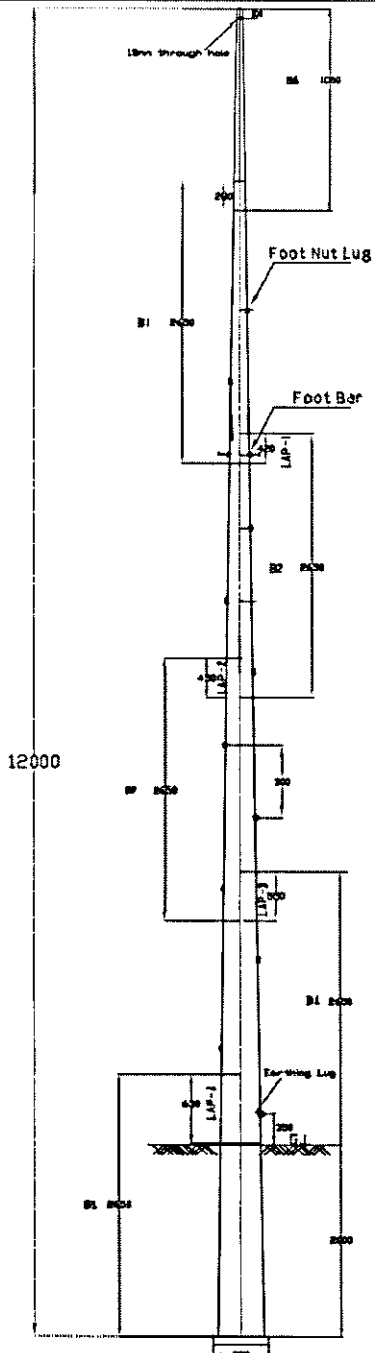

| PARAMETERS          |      |      |      |      |      |      |
|---------------------|------|------|------|------|------|------|
| SECTION             | B1   | B2   | B3   | B4   | B5   | B6   |
| LENGTH(mm)          | 2650 | 2650 | 2650 | 2650 | 2650 | 1080 |
| THICKNESS(mm)       | 2.1  | 2.1  | 2.1  | 2.1  | 2.1  | 2.1  |
| TOP DIAMETER(mm)    | 119  | 180  | 240  | 298  | 352  | 100  |
| BOTTOM DIAMETER(mm) | 197  | 258  | 318  | 375  | 430  | 132  |

| OVERLAPS |                |                |                |                |                |
|----------|----------------|----------------|----------------|----------------|----------------|
| OVERLAPS | LAP-1<br>B1/B2 | LAP-2<br>B2/B3 | LAP-3<br>B3/B4 | LAP-4<br>B4/B5 | LAP-5<br>B5/B1 |
| OVERLAPS | 420            | 450            | 550            | 630            | 280            |

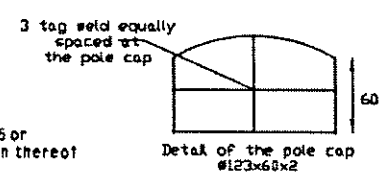
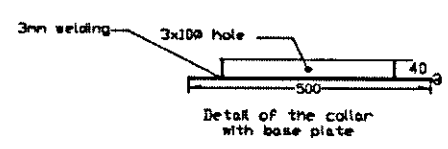
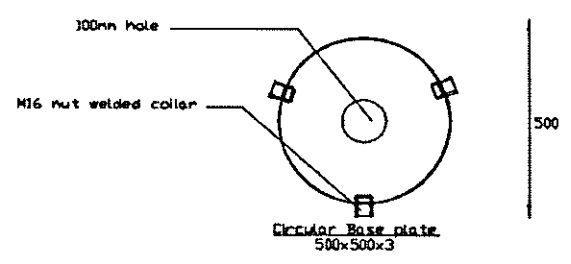
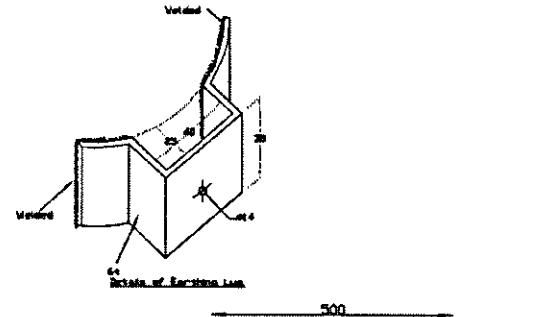

**Note:**  
 \*ALL Parts shall be BS 4360: 1996 Grade 50C and Galvanization as per IS 2629-1995 or BS 729-1971 or Equivalent National or International Standards and any revision thereof  
 \*ALL Dimensions in mm  
 \*Through hole dia 18mm at 100mm from the pole top for shielding wire  
 \*Footing bar distance to be maintained at 300mm

|   |   |      |  |  |
|---|---|------|--|--|
|  | <b>BHUTAN POWER CORPORATION LIMITED</b> |      | <b>ENGINEERING DESIGN &amp; CONTRACTS DEPARTMENT</b>           |  |
|   |   |      | <b>TITLE : DISTRIBUTION DESIGN &amp; CONSTRUCTION STANDARD</b> |  |
| <b>TELESCOPIC POLE DETAILS FOR 12M</b>  |   |      | DRAWING NO. BPC - DDCS - 2015 - 25                             |  |
| DESIGNATION   | NAME                                    | DATE |  |  |
| DRAFTSMAN   |   |      |  |  |
| DESIGNER  |   |      |  |  |
| DESIGN CHECK  |   |      |  |  |
| PROJECT MANAGER   |   |      | REVISION 2015  |  |
| PROJECT DIRECTOR  |   |      |  |  |

Details of Footbar

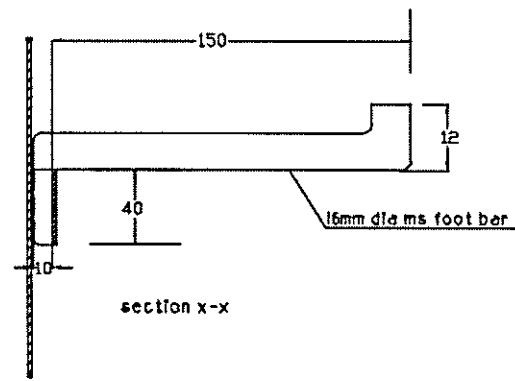
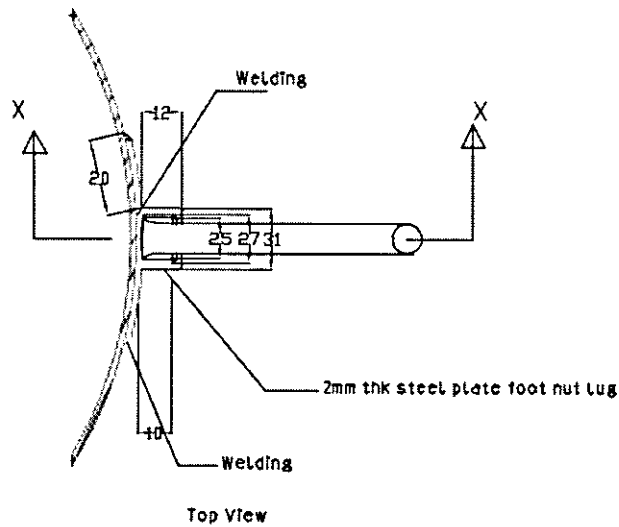

NOTES

1. FERROUS PARTS HOT DIP GALVANIZED AS PER BS-729
2. DIMENSIONS AS SHOWN ARE IN mm.
3. TOLERANCE  $\pm 5\%$
4. DRAWING IS NOT TO SCALE.
5. FOUR NUMBERS PER POLE

|   |                                  |   |                              |
|---|----------------------------------|---|------------------------------|
|  | BHUTAN POWER CORPORATION LIMITED | ENGINEERING DESIGN & CONTRACTS DEPARTMENT   |                              |
|   |                                  | DISTRIBUTION DESIGN & CONSTRUCTION STANDARD |                              |
|   |                                  | Foot Bar for Telescopic Pole                |                              |
| DESIGNATION   | NAME                             | DATE  | DRAWING NO. BPC-DDCS-2015-26 |
| DRAFTSMAN   |                                  |   |                              |
| DESIGNER  |                                  |   |                              |
| DESIGN CHECK  |                                  |   |                              |
| PROJECT MANAGER   |                                  |   |                              |
| PROJECT DIRECTOR  |                                  |   |                              |
|   |                                  |   | REVISION<br>2015             |

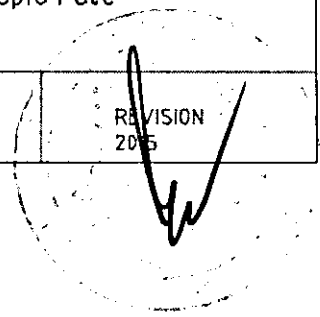

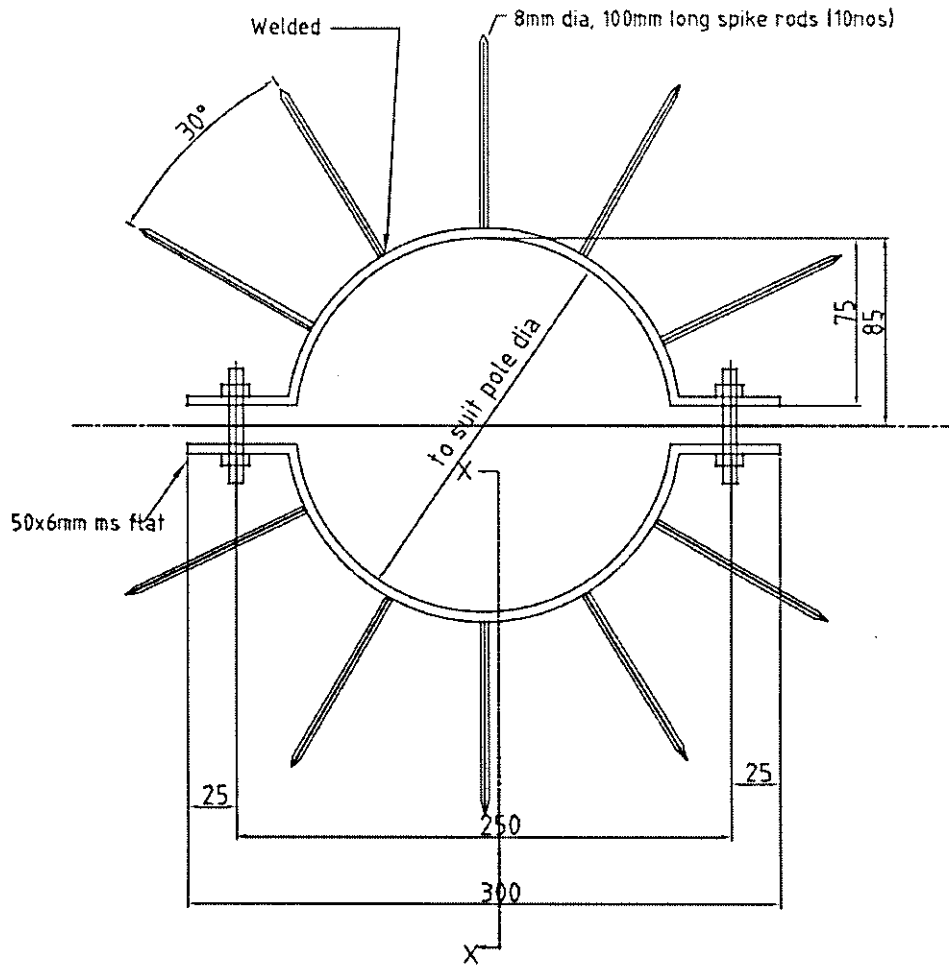

section X-X

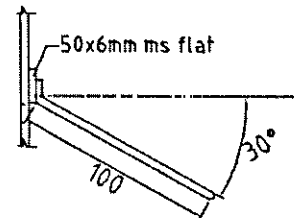

NOTES

1. FERROUS PARTS HOT DIP GALVANIZED AS PER BS-729
2. DIMENSIONS AS SHOWN ARE IN mm.
3. TOLERANCE  $\pm 5\%$
4. DRAWING IS NOT TO SCALE.
5. ONE NUMBER PER POLE

|   |   |  |                              |
|---|---|--|------------------------------|
|  | <b>BHUTAN POWER CORPORATION LIMITED</b> | <b>ENGINEERING DESIGN &amp; CONTRACTS DEPARTMENT</b>   |                              |
|   |   | <b>DISTRIBUTION DESIGN &amp; CONSTRUCTION STANDARD</b> |                              |
|   |   | <b>ANTI-CLIMBING DEVICE</b>                            |                              |
| DESIGNATION   | NAME                                    | DATE   | DRAWING NO. BPC-DDCS-2015-27 |
| DRAFTSMAN   |   |  |                              |
| DESIGNER  |   |  |                              |
| DESIGN CHECK  |   |  |                              |
| PROJECT MANAGER   |   |  |                              |
| PROJECT DIRECTOR  |   |  |                              |
|   |   |  | REVISION<br>2015             |



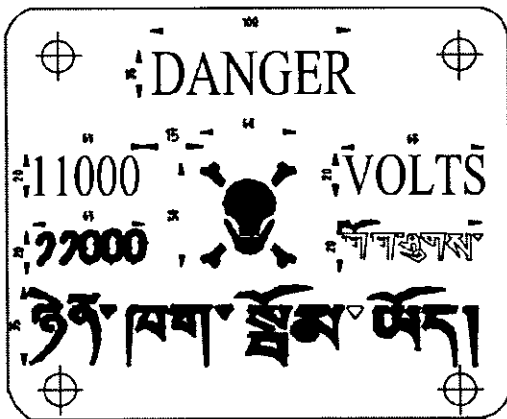

1. DIMENSIONS AS SHOWN ARE IN MM
2. MS PLATE SHALL BE 2MM THICK
3. LETTERING AND FIGURE: RED ENAMELED  
BACK GROUND: WHITE ENAMELED  
BACK OF THE PLATE: BLACK ENAMELED
4. DESIGN OF DANGER PLATE IS AS PER IS:2551
5. CORNERS OF THE PLATE SHALL BE ROUND OFF
6. FASTENERS PER PLATE: 4 NOS. 16MM DIA WITH GI BOLTS
7. ONE DANGER PLATE PER STRUCTURE

|  |   |      |  |  |                                     |
|--|---|------|--|--|-------------------------------------|
|  | <b>BHUTAN POWER CORPORATION LIMITED</b> |      | <b>ENGINEERING DESIGN &amp; CONTRACTS DEPARTMENT</b>   |  |                                     |
|  |   |      | <b>DISTRIBUTION DESIGN &amp; CONSTRUCTION STANDARD</b> |  |                                     |
| <b>DANGER PLATE FOR 33kV and 11kV POLE</b> |   |      |  |  |                                     |
| DESIGNATION                                | NAME                                    | DATE |  |  | <b>DRAWING NO. BPC-DDCS-2015-28</b> |
| DRAFTSMAN                                  |   |      |  |  |                                     |
| DESIGNER                                   |   |      |  |  |                                     |
| DESIGN CHECK                               |   |      |  |  |                                     |
| PROJECT MANAGER                            |   |      |  |  |                                     |
| PROJECT DIRECTOR                           |   |      |  |  |                                     |
|  |   |      | <b>REVISION</b><br>2015                                |  |                                     |

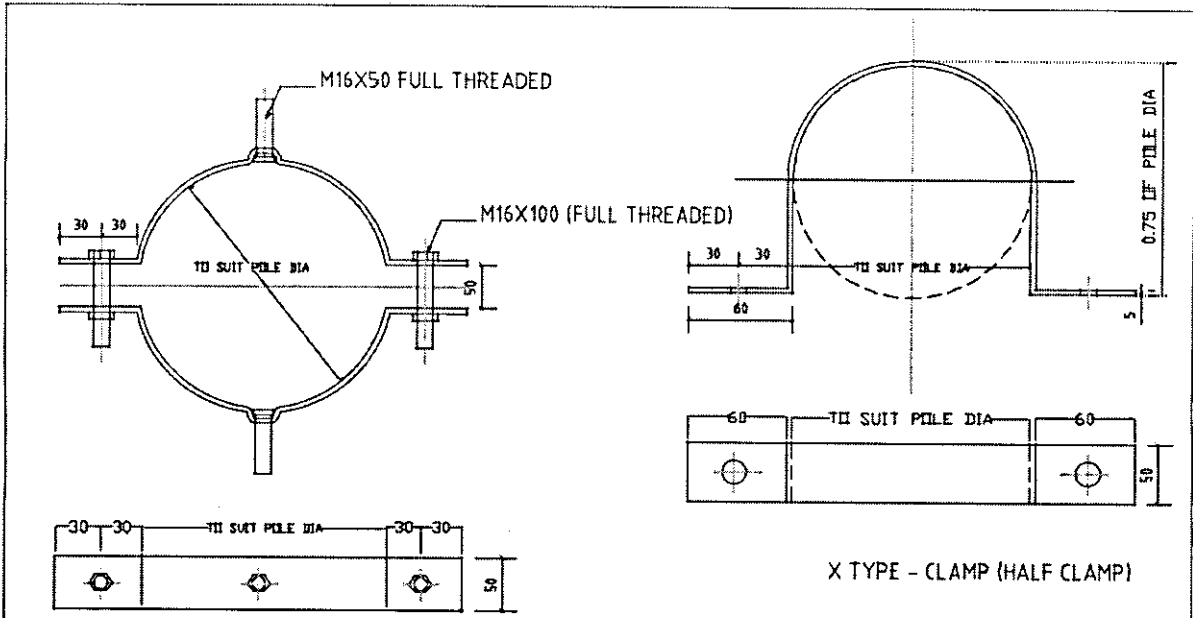

Y TYPE - CLAMP (FULL CLAMP)

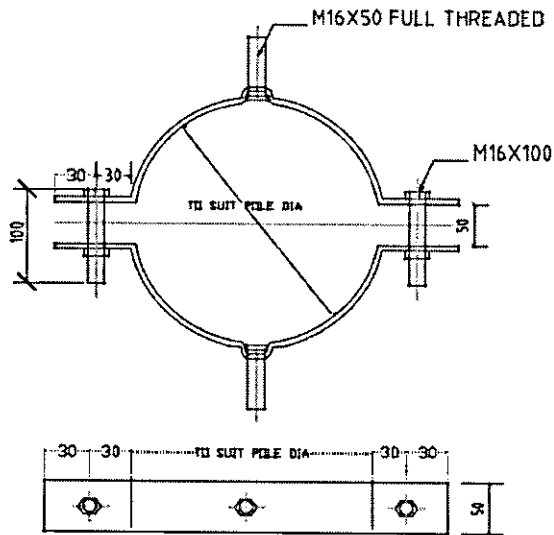

STAY CLAMP

NOTES

1. DIMENSIONS AS SHOWN ARE IN mm.
2. DRAWING IS NOT TO SCALE.
3. ALL MATERIALS SHALL BE GALVANIZED
4. ALL THE BOLTS SHALL BE FULL THREADED TYPE

|                  |                                  |      |   |  |
|------------------|----------------------------------|------|---|--|
|                  | BHUTAN POWER CORPORATION LIMITED |      | ENGINEERING DESIGN & CONTRACTS DEPARTMENT   |  |
|                  |                                  |      | DISTRIBUTION DESIGN & CONSTRUCTION STANDARD |  |
|                  |                                  |      | CLAMPS FOR TELESCOPIC POLE                  |  |
| DESIGNATION      | NAME                             | DATE | DRAWING NO. BPC-DDCS-2015-29                |  |
| DRAFTSMAN        |                                  |      |   |  |
| DESIGNER         |                                  |      |   |  |
| DESIGN CHECK     |                                  |      |   |  |
| PROJECT MANAGER  |                                  |      |   |  |
| PROJECT DIRECTOR |                                  |      | REVISION 2015                               |  |

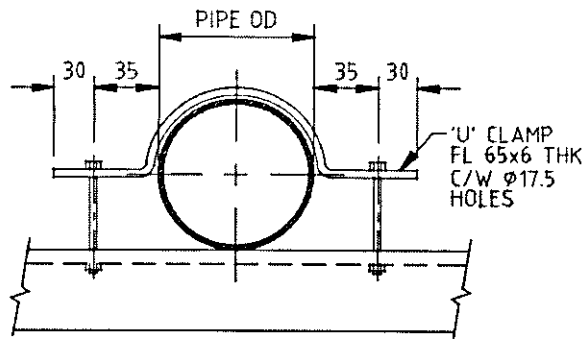

1 'U' CLAMP

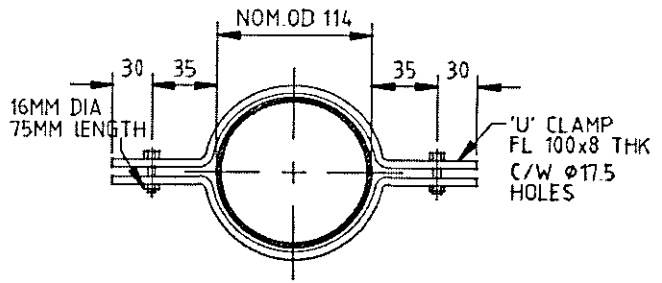

4 STAY CLAMP

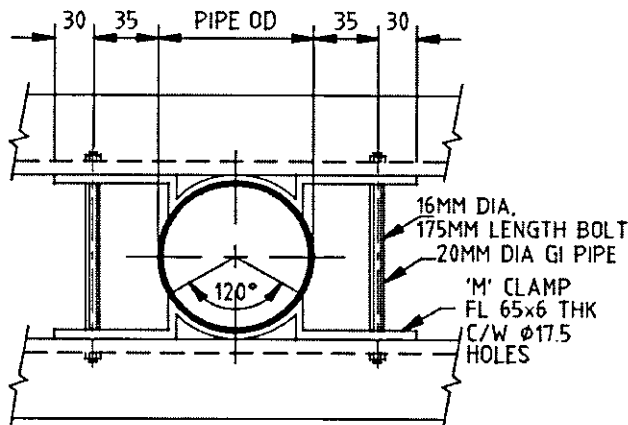

2 'M' CLAMP

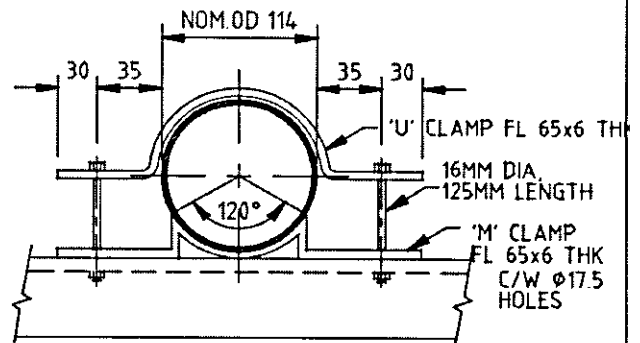

5 CROSS ARM CLAMP (U+M)

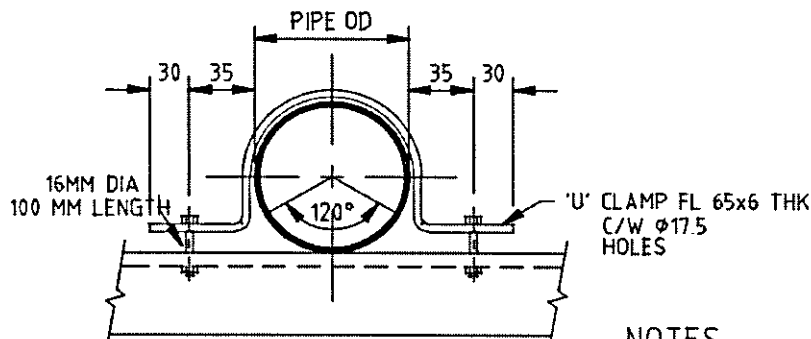

3 FULL CLAMP

NOTES

1. DIMENSIONS AS SHOWN ARE IN mm.
2. DRAWING IS NOT TO SCALE.
3. ALL BOLTS TO BE Ø16 C/W NUTS & SPRING WASHERS.

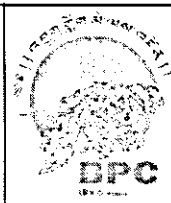

BHUTAN POWER CORPORATION LIMITED

ENGINEERING DESIGN & CONTRACTS DEPARTMENT

TITLE : DISTRIBUTION DESIGN & CONSTRUCTION STANDARD

33 & 11 KV CLAMP DETAILS FOR STEEL TUBULAR POLE

| DESIGNATION      | NAME | DATE |
|------------------|------|------|
| DRAFTSMAN        |      |      |
| DESIGNER         |      |      |
| DESIGN CHECK     |      |      |
| PROJECT MANAGER  |      |      |
| PROJECT DIRECTOR |      |      |

DRAWING NO. BPC-DDCS-2015-30

REVISION 2015

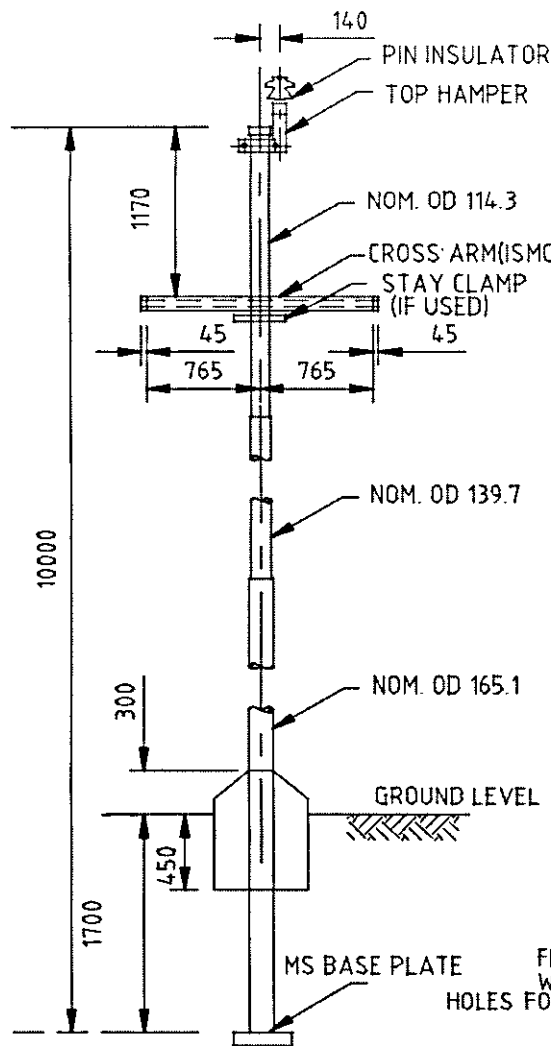

POLE & CROSS ARM ASSEMBLY

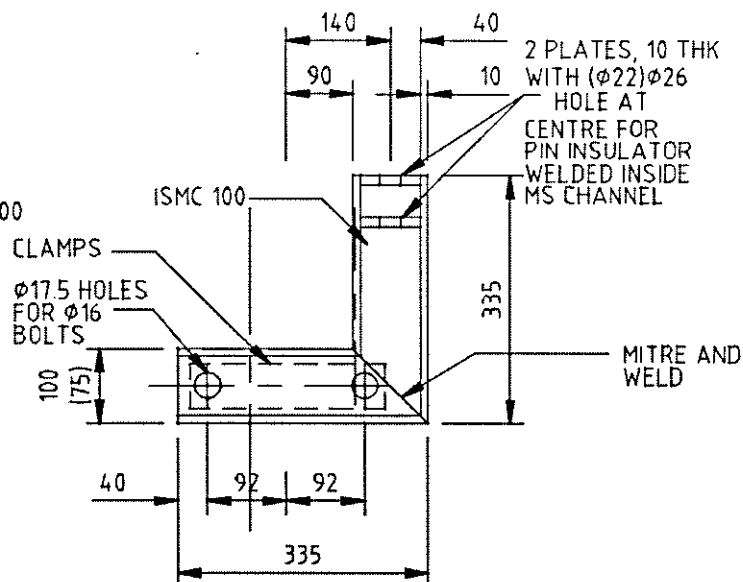

TOP HAMPER FOR INSULATOR PIN DETAIL

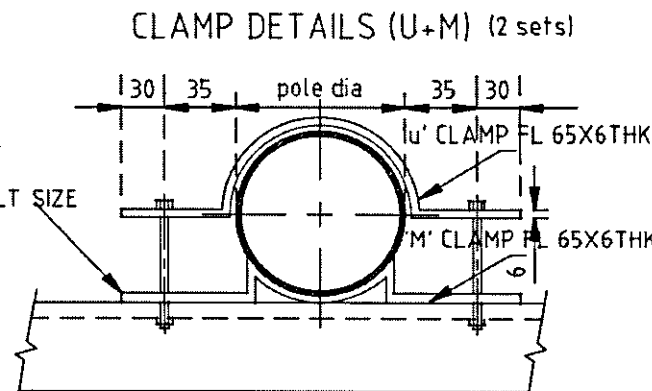

CLAMP DETAILS (U+M) (2 sets)

NOTES

1. DIMENSIONS AS SHOWN ARE IN mm
2. DRAWING IS NOT TO SCALE.
3. ALL NUTS AND BOLTS TO BE HOT DIPPED GALVANISED

|                                |     |           |
|--------------------------------|-----|-----------|
| 10M STEEL TUBULAR POLE         | 1   | STEEL     |
| CROSSARM CHANNEL               | 1   | MS        |
| TOP HAMPER WELDED IN "L" SHAPE | 1   | MS        |
| PIN INSULATOR                  | 3   | PORCELAIN |
| CLAMP WITH NUTS & BOLTS (U+M)  | 2   | MS        |
| STAY SET ASSEMBLY              | 1   | MS        |
| BASE PLATE                     | 1   | MS        |
| DESCRIPTION                    | QTY | MATERIAL  |

BHUTAN POWER CORPORATION LIMITED

ENGINEERING DESIGN & CONTRACTS DEPARTMENT

DISTRIBUTION DESIGN & CONSTRUCTION STANDARD

STEEL TUBULAR-SINGLE POLE STRUCTURE DETAILS  
11 & 33 KV

| DESIGNATION      | NAME | DATE |
|------------------|------|------|
| DRAFTSMAN        |      |      |
| DESIGNER         |      |      |
| DESIGN CHECK     |      |      |
| PROJECT MANAGER  |      |      |
| PROJECT DIRECTOR |      |      |

DRAWING NO. BPC-DDCS-2015-31

REVISION 2015

BRACING ASSEMBLY DETAILS

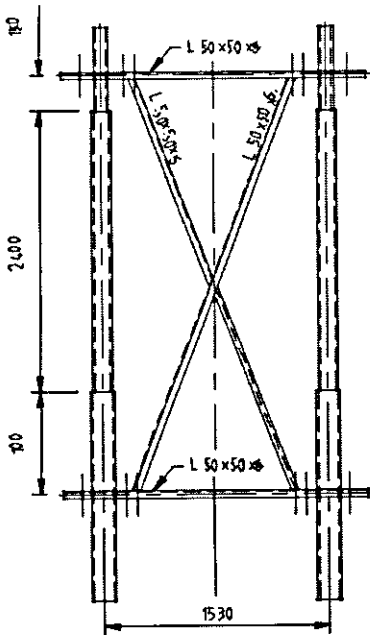

(9000)  
10000

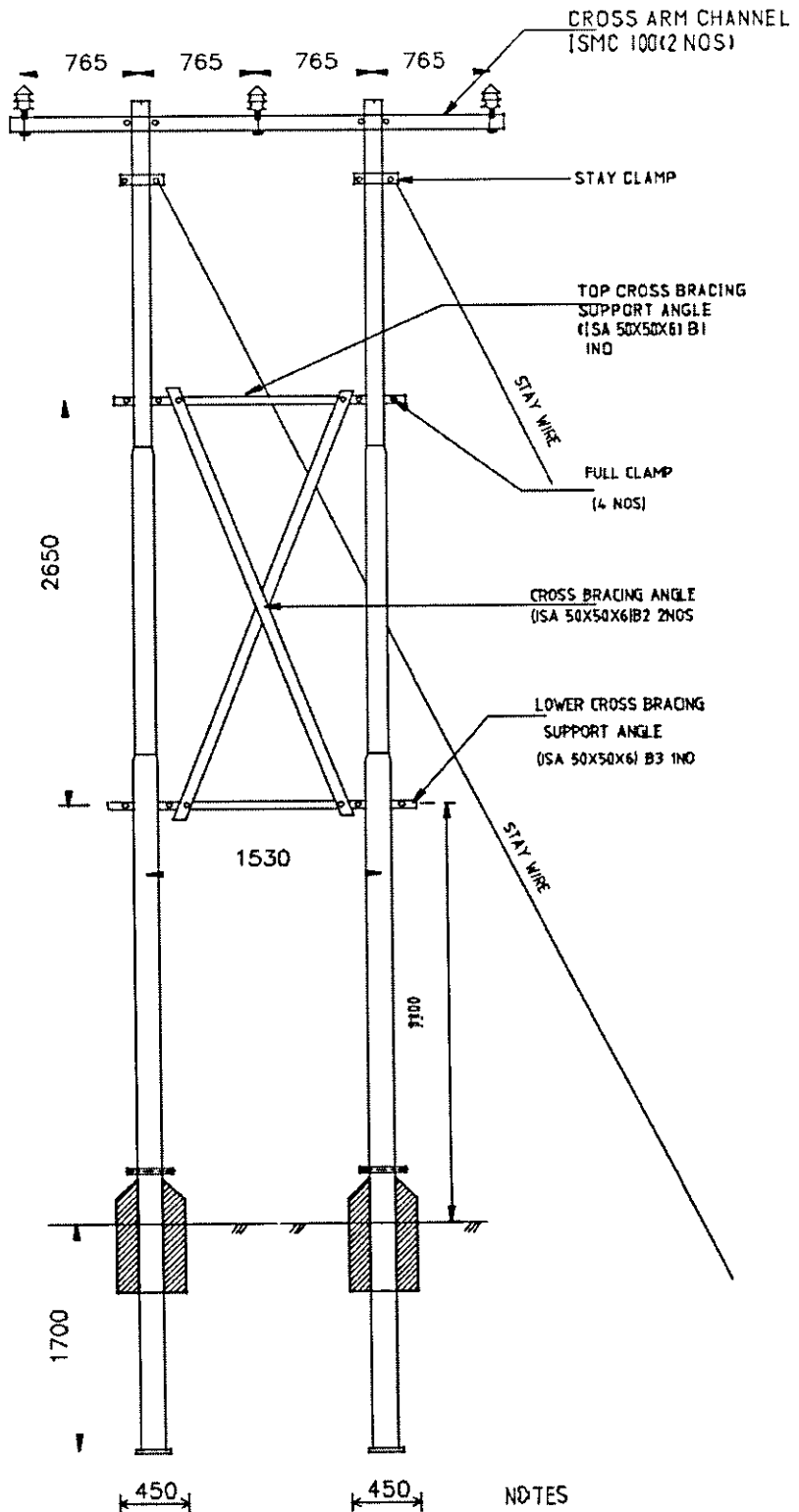

NOTES

1. DIMENSIONS AS SHOWN ARE IN mm
2. DRAWING IS NOT TO SCALE.

| DESCRIPTION                   | QTY | MATERIAL  |
|-------------------------------|-----|-----------|
| 19M I.D.M STEEL TUBULAR POLE  | 2   | STEEL     |
| CROSS ARM CHANNEL             | 2   | MS        |
| DISC INSULATOR SET            | 6   | PORCELAIN |
| PIN INSULATOR SET             | 3   | PORCELAIN |
| CLAMP WITH NUTS & BOLTS (U-M) | 2   | MS        |
| STAY SET ASSEMBLY             | 2   | MS        |
| BASE PLATE                    | 2   | MS        |

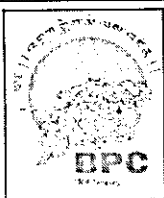

BHUTAN POWER CORPORATION LIMITED

ENGINEERING DESIGN & CONTRACTS DEPARTMENT

DISTRIBUTION DESIGN & CONSTRUCTION STANDARD

11kV 33KV H-FRAME

DOUBLE POLE ARRANGEMENT (STEEL TUBULAR POLES)

| DESIGNATION      | NAME | DATE |
|------------------|------|------|
| DRAFTSMAN        |      |      |
| DESIGNER         |      |      |
| DESIGN CHECK     |      |      |
| PROJECT MANAGER  |      |      |
| PROJECT DIRECTOR |      |      |

DRAWING NO. BPC-DDCS-2015-32/1

REVISION  
2015

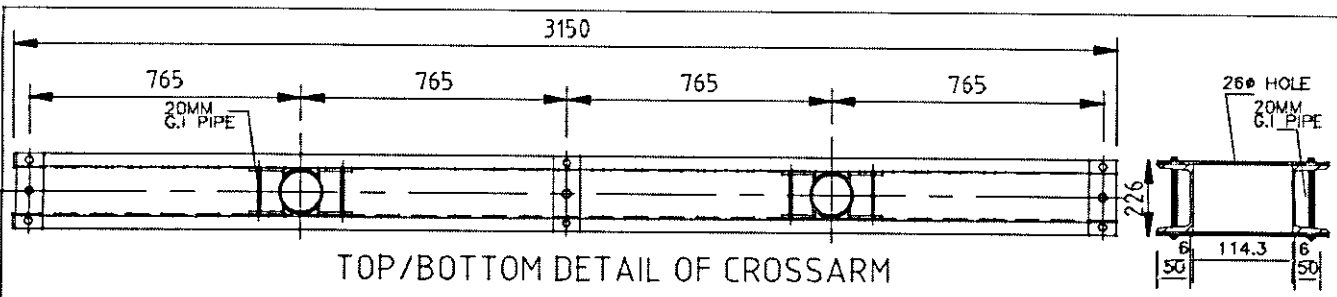

TOP/BOTTOM DETAIL OF CROSSARM  
ISMC 100x50 (2NOS)

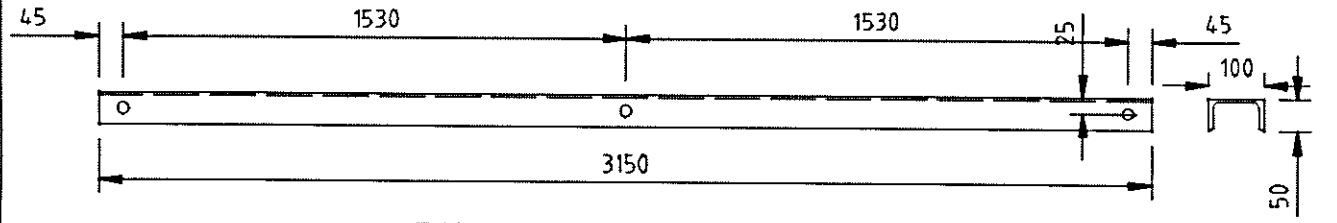

TOP VIEW OF CROSSARM - CHL  
ISMC 100x50 (2 NOS)

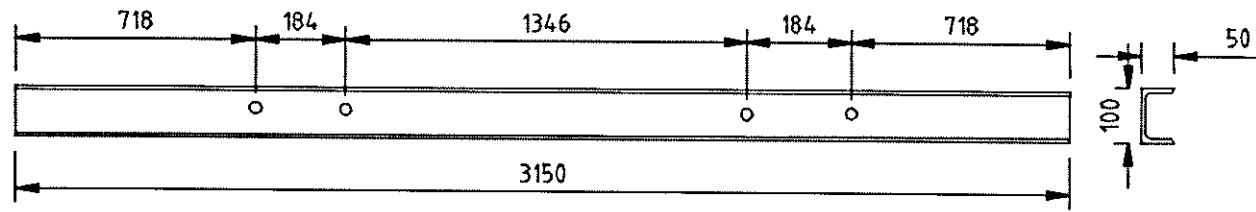

FRONT VIEW OF CROSSARM - CHL  
ISMC 100x50 (2 NOS)

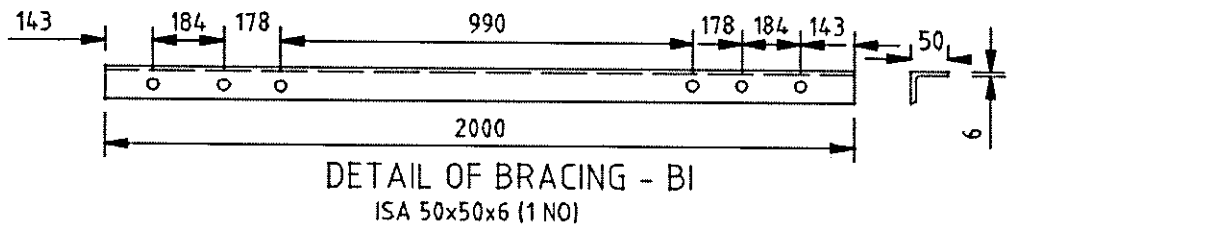

DETAIL OF BRACING - B1  
ISA 50x50x6 (1 NO)

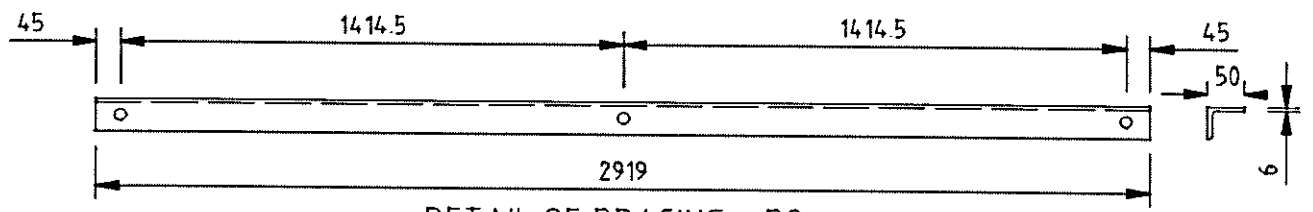

DETAIL OF BRACING - B2  
ISA 50x50x6 (2 NOS)

- NOTES
1. DIMENSIONS AS SHOWN ARE IN mm.
  2. DRAWING IS NOT TO SCALE.
  3. ALL BOLT HOLES TO BE 18MM EXCEPT FOR THE ONE INDICATED.



BHUTAN POWER CORPORATION LIMITED

ENGINEERING DESIGN & CONTRACTS DEPARTMENT

DISTRIBUTION DESIGN & CONSTRUCTION STANDARD

11 & 33 KV H-FRAME

CHANNEL & BRACING DETAIL (STEEL TUBULAR ROLES)

| DESIGNATION      | NAME | DATE |
|------------------|------|------|
| DRAFTSMAN        |      |      |
| DESIGNER         |      |      |
| DESIGN CHECK     |      |      |
| PROJECT MANAGER  |      |      |
| PROJECT DIRECTOR |      |      |

DRAWING NO. BPC-DDCS-2015-32/2

REVISION  
2015

### DETAIL OF BRACING - B3

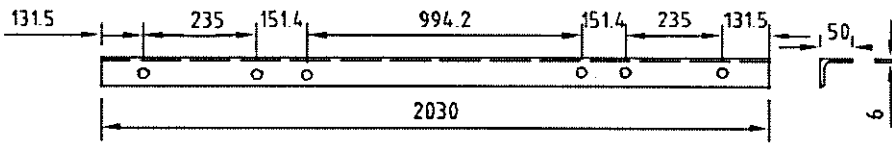

ISA 50x50x6 (1 NO)

### DETAIL OF MS STRING LACING FLAT

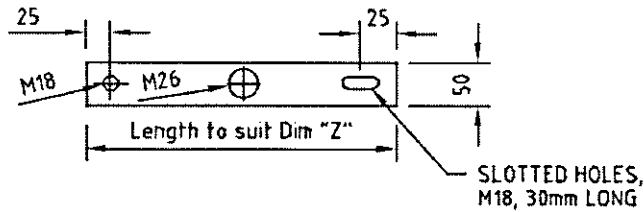

FL 50x6 (6 NOS)  
GI 16MM DIA NUTS AND BOLTS (6NOS)

### FIXING OF PIN AND DISC INSULATOR ON CROSSARM

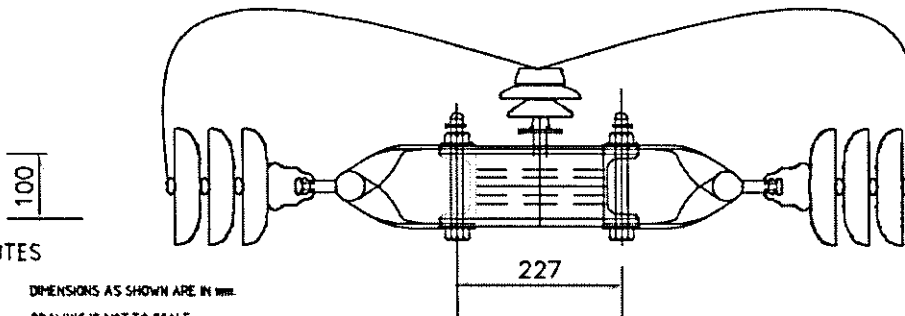

#### NOTES

1. DIMENSIONS AS SHOWN ARE IN mm.
2. DRAWING IS NOT TO SCALE.
3. STANDARDS  
IS 2062-1992/IS 1161 OR EQUIVALENT STEEL FOR GENERAL STRUCTURAL PURPOSES  
IS 808-1964 OR EQUIVALENT DIMENSIONS FOR HOT ROLLED STEEL BEAM COLUMN CHANNEL AND ANGLE SECTION
4. MINIMUM TENSILE STRENGTH - 420 MPA
5. ALL ITEMS SHALL BE MILD STEEL (MS) PAINTED WITH ONE COAT OF RED OXIDE PRIMER IN ACCORDANCE WITH ISO 12914-1 OR ANY OTHER EQUIVALENT INTERNATIONAL STANDARD. HOWEVER, NUTS AND BOLTS SHALL BE HOT DIPPED GALVANISED WITH ZINC COATING 600 GRAM PER SQUARE METER.
6. DISC ARRANGEMENT IS SHOWN FOR 33KV SYSTEM, TAKE ONE DISC INSULATOR FOR 11KV SYSTEM

|   |                                  |   |  |
|---|----------------------------------|---|--|
|  | BHUTAN POWER CORPORATION LIMITED | ENGINEERING DESIGN & CONTRACTS DEPARTMENT                         |  |
|   |                                  | DISTRIBUTION DESIGN & CONSTRUCTION STANDARD<br>11 & 33 KV H-FRAME |  |
| DESIGNATION   | NAME                             | DATE  | CHANNEL & BRACING DETAIL (STEEL TUBULAR POLES)<br><br>DRAWING NO. BPC-DDCS-2015-32/3 |
| DRAFTSMAN   |                                  |   |  |
| DESIGNER  |                                  |   |  |
| DESIGN CHECK  |                                  |   |  |
| PROJECT MANAGER   |                                  |   |  |
| PROJECT DIRECTOR  |                                  |   | REVISION<br>2015   |

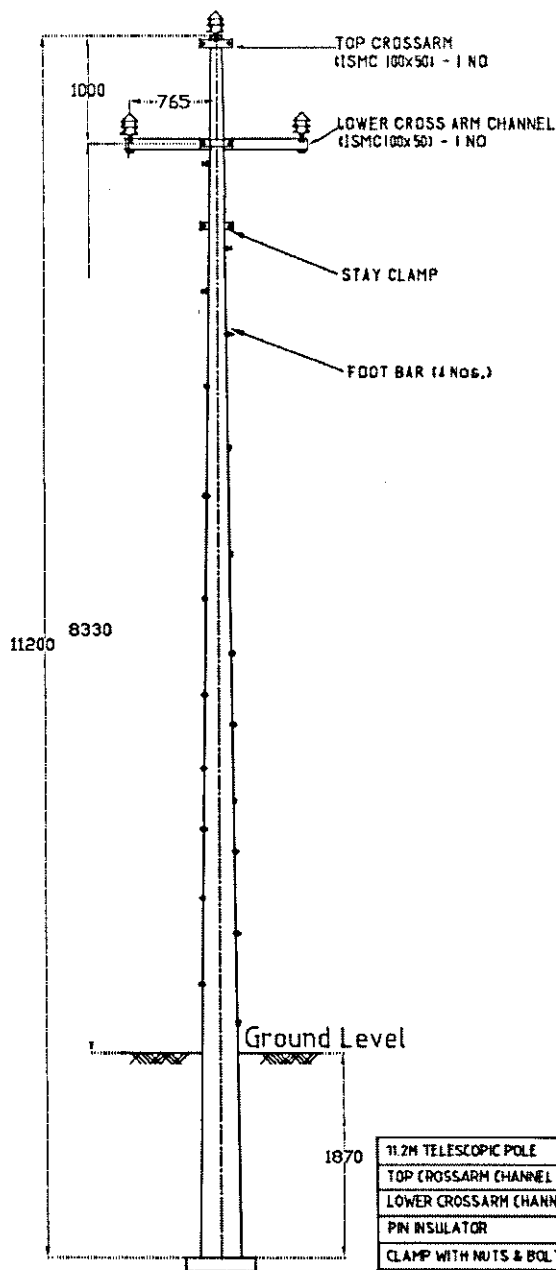

**NOTES**

- 1 DIMENSIONS AS SHOWN ARE IN mm.
- 2 DRAWING IS NOT TO SCALE.

| DESCRIPTION             | QTY | MATERIAL  |
|-------------------------|-----|-----------|
| 11.2M TELESCOPIC POLE   | 1   | GS        |
| TOP CROSSARM CHANNEL    | 1   | GS        |
| LOWER CROSSARM CHANNEL  | 1   | GS        |
| PN INSULATOR            | 3   | PORCELAIN |
| CLAMP WITH NUTS & BOLTS | 2   | GS        |
| STAY SET ASSEMBLY       | 1   | GS        |
| BASE PLATE              | 1   | GS        |

|   |   |  |   |
|---|---|--|---|
|  | <b>BHUTAN POWER CORPORATION LIMITED</b> | <b>ENGINEERING DESIGN &amp; CONTRACTS DEPARTMENT</b>   |   |
|   |   | <b>DISTRIBUTION DESIGN &amp; CONSTRUCTION STANDARD</b> |   |
| <b>SINGLE POLE ASSEMBLY - 11.2 M TELESCOPIC POLE (11 KV &amp; 33KV)</b>             |   |  |   |
| DESIGNATION   | NAME                                    | DATE   |   |
| DRAFTSMAN   |   |  |   |
| DESIGNER  |   |  |   |
| DESIGN CHECK  |   |  |   |
| PROJECT MANAGER   |   |  |   |
| PROJECT DIRECTOR  |   |  |   |
|   |   |  | DRAWING NO. BPC-DDCS-2015-33/1<br>REVISION 2015 |



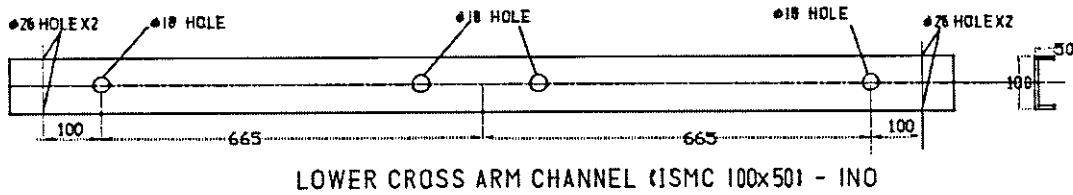
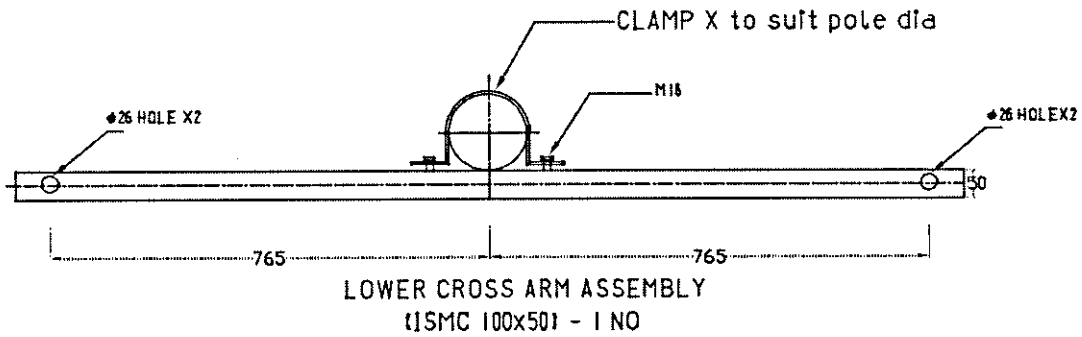
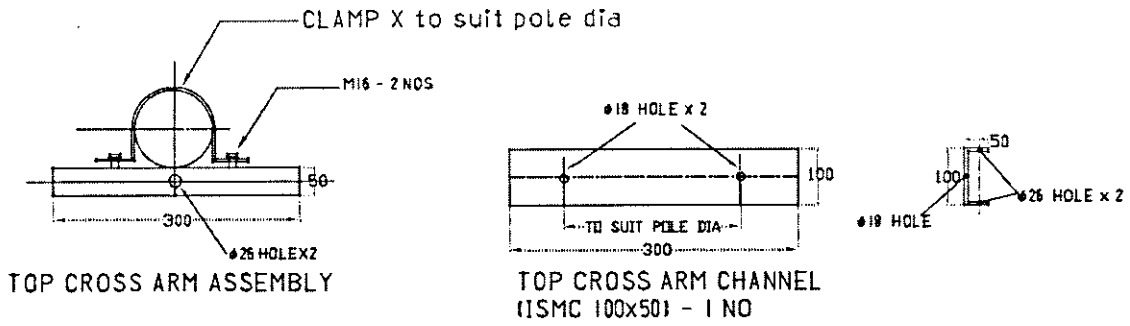

**NOTES**

1. DIMENSIONS AS SHOWN ARE IN mm.
2. DRAWING IS NOT TO SCALE.
3. LENGTH OF THE BRACING ANGLE SHALL BE DESIGNED BY THE SUPPLIER

|   |   |      |  |  |
|---|---|------|--|--|
| <br><b>BPC</b> | <b>BHUTAN POWER CORPORATION LIMITED</b> |      | <b>ENGINEERING DESIGN &amp; CONTRACTS DEPARTMENT</b>                             |  |
|   |   |      | <b>DISTRIBUTION DESIGN &amp; CONSTRUCTION STANDARD</b>                           |  |
|   |   |      | <b>SINGLE POLE CROSS ARM ASSEMBLY - 11.2M TELESCOPIC POLE (11 kV &amp; 33kV)</b> |  |
| DESIGNATION   | NAME                                    | DATE | DRAWING NO. BPC-DDCS-2015-33/2   |  |
| DRAFTSMAN   |   |      |  |  |
| DESIGNER  |   |      |  |  |
| DESIGN CHECK  |   |      |  |  |
| PROJECT MANAGER   |   |      |  |  |
| PROJECT DIRECTOR  |   |      | REVISION<br>01/15  |  |

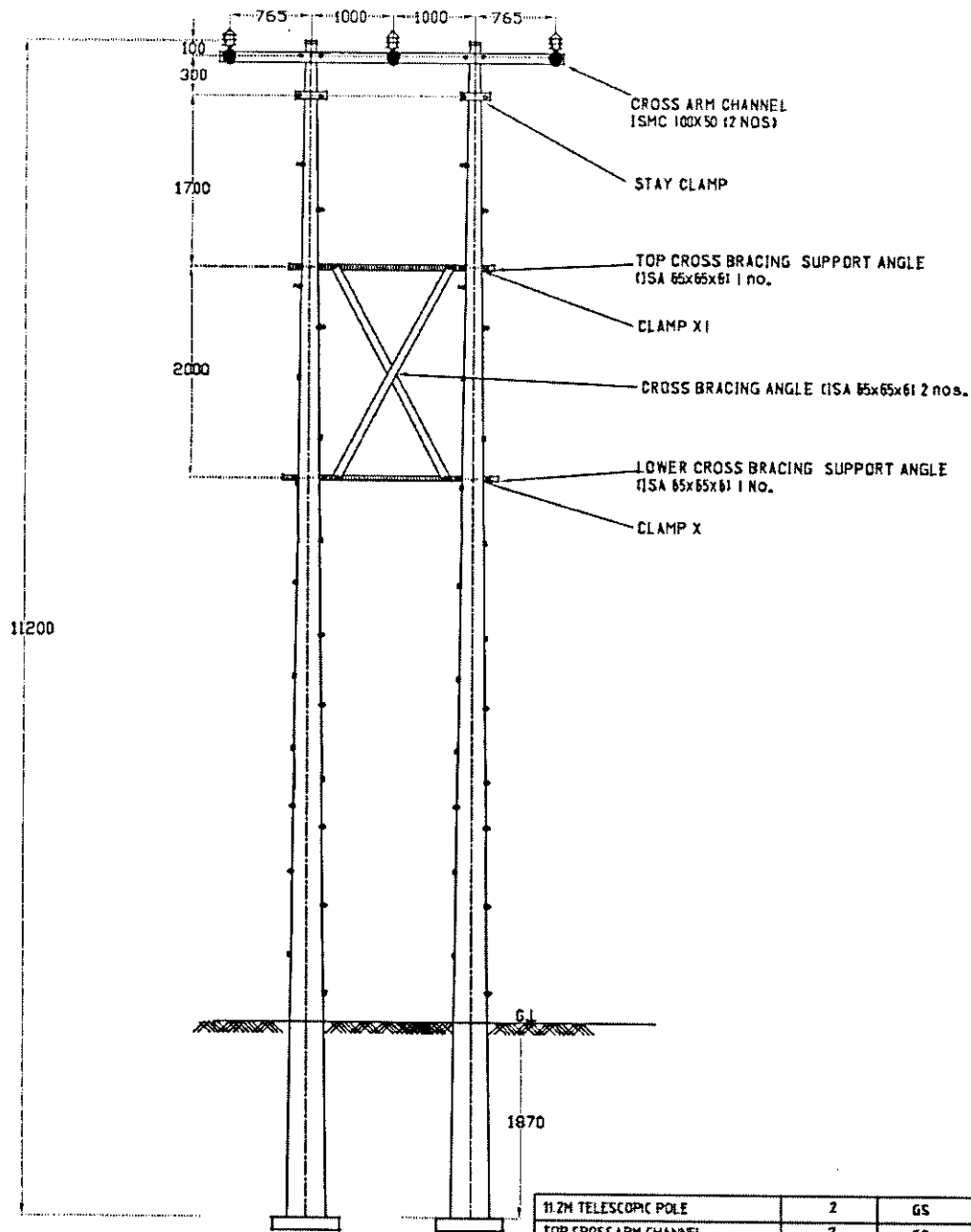

**NOTES**

1. DIMENSIONS AS SHOWN ARE IN mm.
2. DRAWING IS NOT TO SCALE.

| DESCRIPTION             | QTY | MATERIAL  |
|-------------------------|-----|-----------|
| 11.2M TELESCOPIC POLE   | 2   | GS        |
| TOP CROSSARM CHANNEL    | 2   | GS        |
| DISC INSULATOR SET      | 6   | PORCELAIN |
| PIN INSULATOR           | 3   | PORCELAIN |
| CLAMP WITH NUTS & BOLTS | 2   | GS        |
| STAY SET ASSEMBLY       | 1   | GS        |
| BASE PLATE              | 1   | GS        |

|  |   |                  |
|--|---|------------------|
| <p><b>BHUTAN POWER CORPORATION LIMITED</b></p>               | ENGINEERING DESIGN & CONTRACTS DEPARTMENT   |                  |
|  | DISTRIBUTION DESIGN & CONSTRUCTION STANDARD |                  |
| DOUBLE POLE ASSEMBLY - 11.2 M TELESCOPIC POLE (11 KV & 33KV) |   |                  |
| DESIGNATION  | NAME  | DATE             |
| DRAFTSMAN  |   |                  |
| DESIGNER   |   |                  |
| DESIGN CHECK   |   |                  |
| PROJECT MANAGER  |   |                  |
| PROJECT DIRECTOR   |   |                  |
| DRAWING NO. BPC-DDCS-2015-34/1                               |   | REVISION<br>2015 |

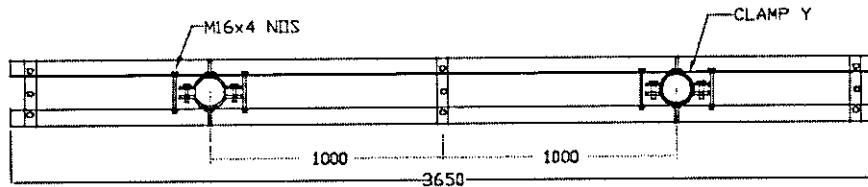

CROSS ARM ASSEMBLY PLAN

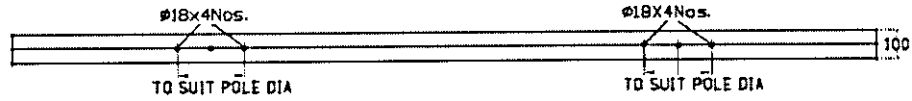

CROSS ARM CHANNEL (ISM 100x50) - ELEVATION



CROSS ARM CHANNEL (ISM 100x50) - PLAN

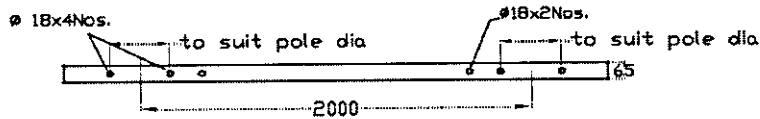

ANGLE FOR TOP CROSS BRACING SUPPORT (ISA 65x40x6) - 1 NO

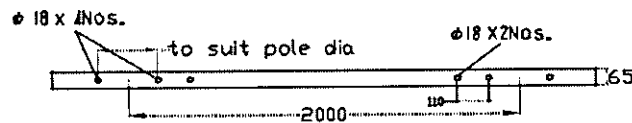

ANGLE FOR LOWER CROSS BRACING SUPPORT (ISA 65x65x6) - 1 NO



ANGLE FOR CROSS BRACING (ISA 65 x 65 x 6) - 2 NOS

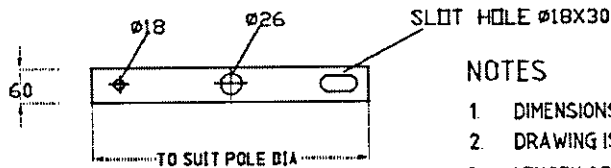

MS TENSION STRAP (60x6) - 6 NOS

NOTES

1. DIMENSIONS AS SHOWN ARE IN mm.
2. DRAWING IS NOT TO SCALE.
3. LENGTH OF THE CROSS BRACING ANGLE SHALL BE DESIGNED BY THE SUPPLIER

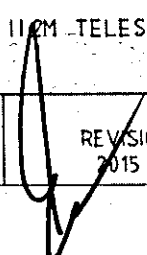
|   |   |      |   |                  |                                |
|---|---|------|---|------------------|--------------------------------|
|  | <b>BHUTAN POWER CORPORATION LIMITED</b> |      | <b>ENGINEERING DESIGN &amp; CONTRACTS DEPARTMENT</b>                                  |                  |                                |
|   |   |      | <b>DISTRIBUTION DESIGN &amp; CONSTRUCTION STANDARD</b>                                |                  |                                |
| <b>DOUBLE POLE CROSS ARM ASSEMBLY - 110M TELESCOPIC POLE (11KV &amp; 33KV)</b>      |   |      |  |                  |                                |
| DESIGNATION   | NAME                                    | DATE |   |                  | DRAWING NO. BPC-DDCS-2015-34/2 |
| DRAFTSMAN   |   |      |   |                  |                                |
| DESIGNER  |   |      |   |                  |                                |
| DESIGN CHECK  |   |      |   |                  |                                |
| PROJECT MANAGER   |   |      |   |                  |                                |
| PROJECT DIRECTOR  |   |      |   | REVISION<br>2015 |                                |

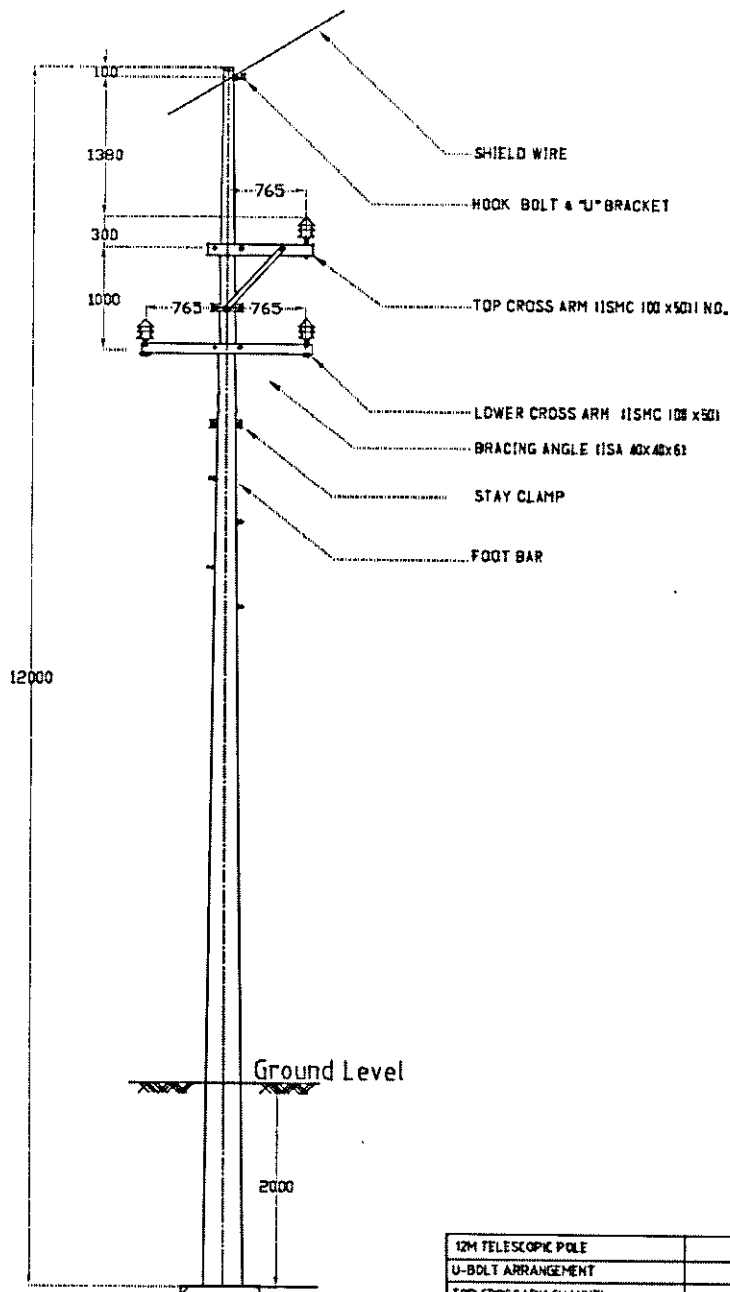

**NOTES**

1. DIMENSIONS AS SHOWN ARE IN mm.
2. DRAWING IS NOT TO SCALE.
3. PROVIDE 18MM DIA THROUGH HOLE AT 100MM BELOW THE POLE TOP FOR FIXING THE HOOK BOLT & U-BRACKET

|                         |     |           |
|-------------------------|-----|-----------|
| 12M TELESCOPIC POLE     | 2   | GS        |
| U-BOLT ARRANGEMENT      | 1   | GS        |
| TOP CROSSARM CHANNEL    | 1   | GS        |
| LOWER CROSSARM CHANNEL  | 1   | GS        |
| PIN INSULATOR           | 3   | PORCELAIN |
| CLAMP WITH NUTS & BOLTS | 1   | GS        |
| STAY CLAMP              | 1   | GS        |
| DESCRIPTION             | QTY | MATERIAL  |

|  |  |                  |
|--|--|------------------|
|  <p><b>BHUTAN POWER CORPORATION LIMITED</b></p> | <b>ENGINEERING DESIGN &amp; CONTRACTS DEPARTMENT</b>   |                  |
|  | <b>DISTRIBUTION DESIGN &amp; CONSTRUCTION STANDARD</b> |                  |
| <b>SINGLE POLE ASSEMBLY FOR 12 M TELESCOPIC POLE WITH GROUNDWIRE (11 KV &amp; 33KV)</b>  |  |                  |
| DESIGNED BY  | NAME   | DATE             |
| CHECKED BY   |  |                  |
| APPROVED BY  |  |                  |
| DRAWING NO. BPC-DDCS-2015-35/1   |  | REVISION<br>2015 |

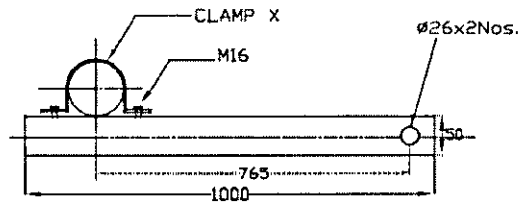

TOP CROSS ARM ASSEMBLY  
(SMC 100x50 (1 no))

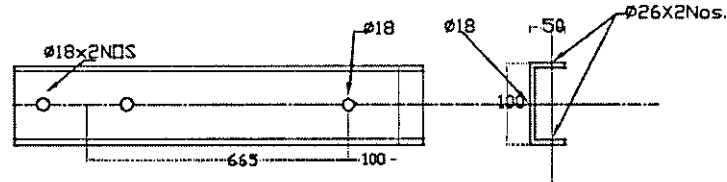

TOP CROSS ARM CHANNEL (SMC 100x50x1000) - 1 NO

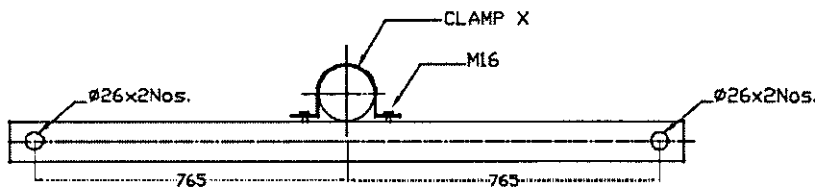

LOWER CROSS ARM ASSEMBLY  
(SMC 100x50 (1 no.))

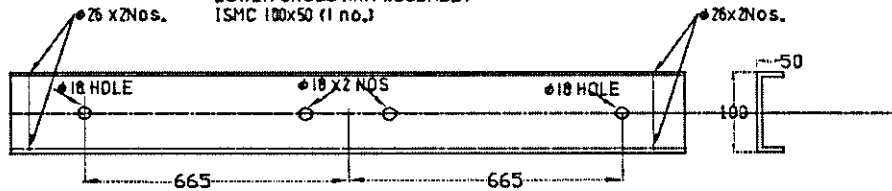

LOWER CROSS ARM CHANNEL (SMC 100x50x1650) - 1 NO

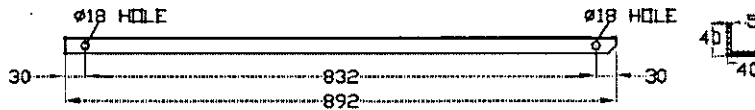

BRACING ANGLE (ISA 100x100x5) - 1 NO

**NOTES**

1. DIMENSIONS AS SHOWN ARE IN mm.
2. DRAWING IS NOT TO SCALE.
3. LENGTH OF THE BRACING ANGLE SHALL BE DESIGNED BY THE SUPPLIER

|   |   |  |                                |
|---|---|--|--------------------------------|
| <br><b>BPC</b> | <b>BHUTAN POWER CORPORATION LIMITED</b>   | <b>ENGINEERING DESIGN &amp; CONTRACTS DEPARTMENT</b> |                                |
|   | <b>TITLE : DISTRIBUTION DESIGN &amp; CONSTRUCTION STANDARD</b><br><b>SINGLE POLE ASSEMBLY FOR 12 M TELESCOPIC POLE WITH GROUNDWIRE (11 KV &amp; 33KV)</b> |  |                                |
| DESIGNED BY   | NAME  | DATE   | DRAWING NO. BPC-DDCS-2015-35/2 |
| CHECKED BY  |   |  |                                |
| APPROVED BY   |   |  |                                |
|   |   |  | REVISION<br>2015               |

12m Pole

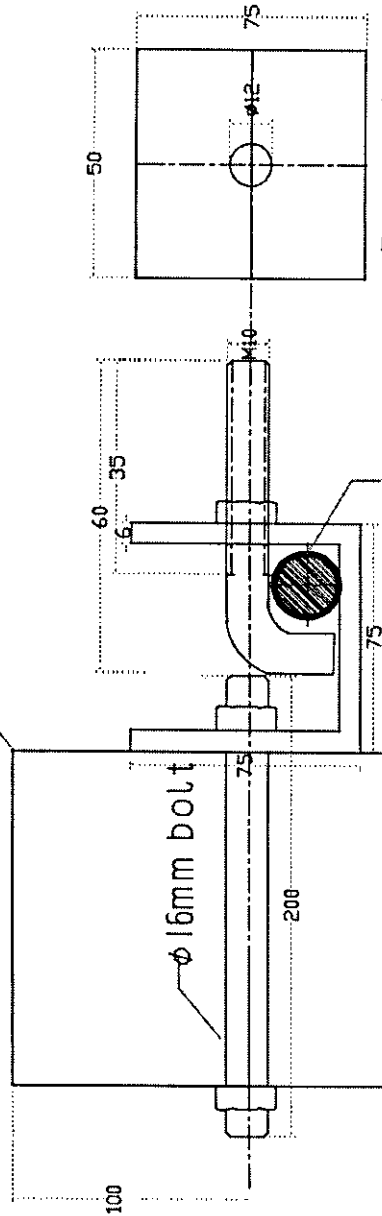

Front View

Shielding Wire

| SL# | DESCRIPTION  | QUANTITY | MATERIAL  |
|-----|--|----------|-----------|
| 1   | 200mm long bolt with nut and washer, threaded at both ends                 | 1        | HDG Steel |
| 2   | U-Type Connector of 75x50x6 with $\phi 12$ mm hole and $\phi 17.5$ mm hole | 1        | HDG Steel |
| 3   | L-Bolt of $\phi 10$ 35mm long threaded                                     | 1        | HDG Steel |



BHUTAN POWER CORPORATION LIMITED

ENGINEERING DESIGN & CONTRACTS DEPARTMENT

TITLE NAME DATE

DESIGNED BY

CHECKED BY

APPROVED BY

DISTRIBUTION DESIGN & CONSTRUCTION STANDARD

U-BOLT FOR SHIELD WIRE FOR SINGLE POLE STRUCTURE

DRAWING NO. BPC-DDCS-2015-35/3

REVISION  
2015

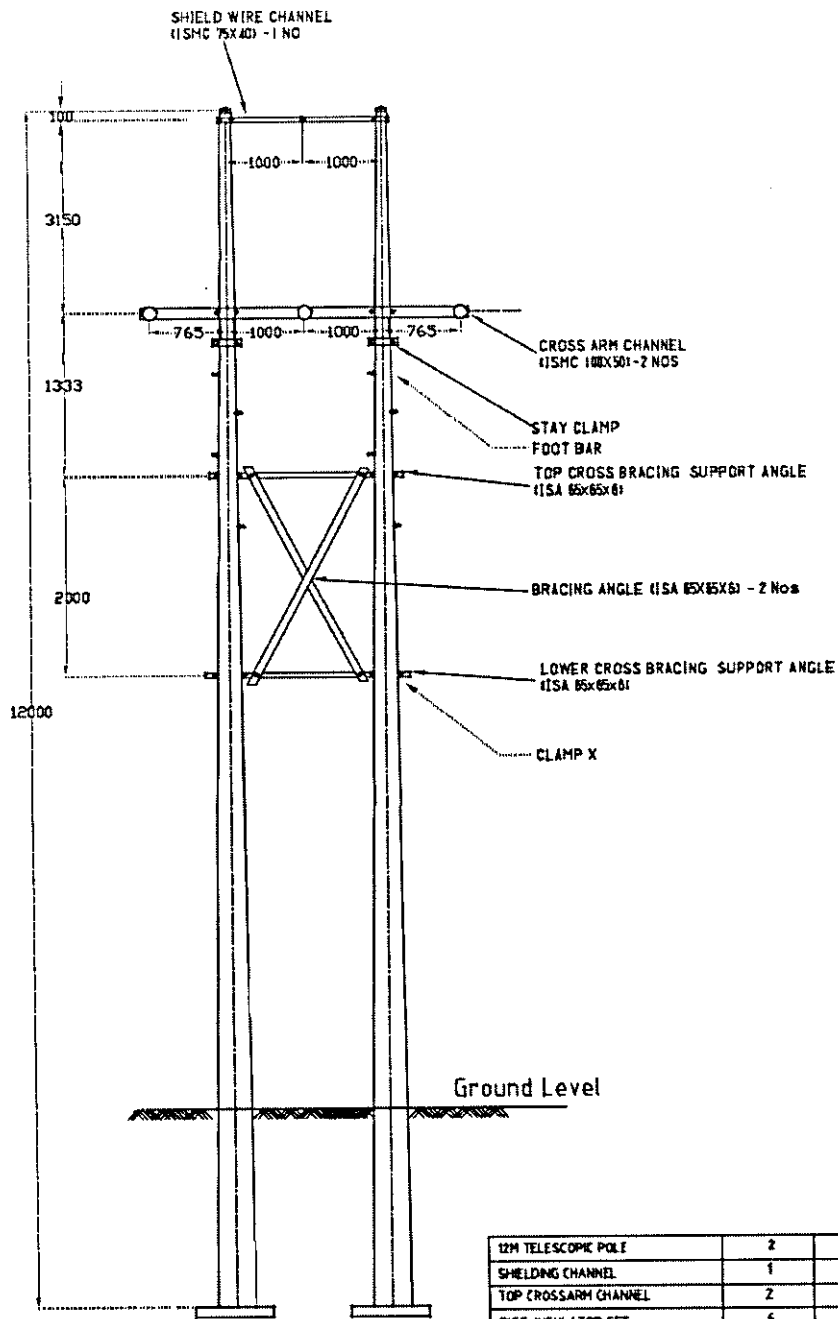

**NOTES**

DIMENSIONS AS SHOWN ARE IN mm.  
DRAWING IS NOT TO SCALE.

|                         |     |           |
|-------------------------|-----|-----------|
| 12M TELESCOPIC POLE     | 2   | GS        |
| SHIELDING CHANNEL       | 1   | GS        |
| TOP CROSSARM CHANNEL    | 2   | GS        |
| DISC INSULATOR SET      | 6   | PORCELAIN |
| PIN INSULATOR SET       | 3   | PORCELAIN |
| CLAMP WITH NUTS & BOLTS | 1   | GS        |
| BRACING ANGLE SET       | 1   | GS        |
| STAY CLAMP SET          | 2   | GS        |
| DESCRIPTION             | QTY | MATERIAL  |

|  |   |               |
|--|---|---------------|
|  <p><b>BHUTAN POWER CORPORATION LIMITED</b></p> | ENGINEERING DESIGN & CONTRACTS DEPARTMENT   |               |
|  | DISTRIBUTION DESIGN & CONSTRUCTION STANDARD |               |
| DOUBLE POLE ASSEMBLY FOR 12M TELESCOPIC POLE WITH GROUNDWIRE (11 kV & 33kV)  |   |               |
| DESIGNED BY  | NAME  | DATE          |
| CHECKED BY   |   |               |
| APPROVED BY  |   |               |
| DRAWING NO. BPC-DDCS-2015-35/1   |   | REVISION 2015 |

SHIELD WIRE CROSSARM ASSEMBLY  
ISMC 75X40, 1 NO.

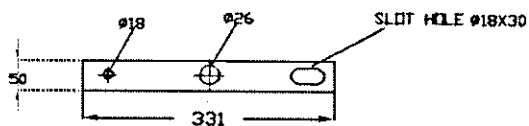
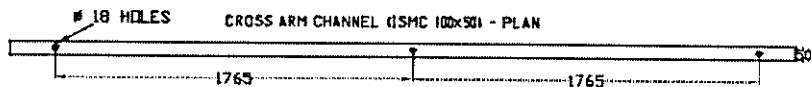
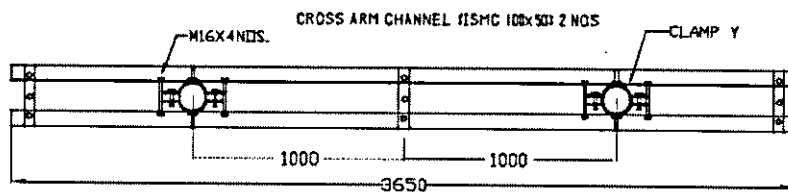
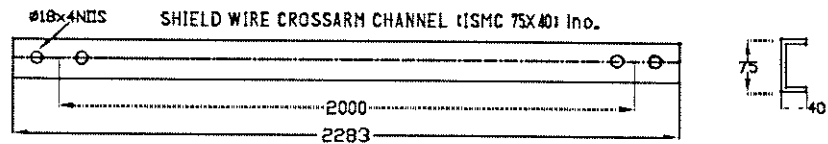
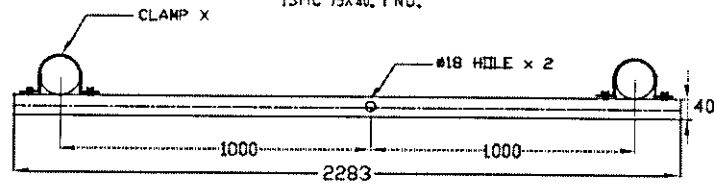

MS TENSION STRAP (50x6) - 8 NOS

NOTES

1. DIMENSIONS AS SHOWN ARE IN mm.
2. DRAWING IS NOT TO SCALE.

|             |                                  |  |   |                  |
|-------------|----------------------------------|--|---|------------------|
|             | BHUTAN POWER CORPORATION LIMITED |  | ENGINEERING DESIGN & CONTRACTS DEPARTMENT           |                  |
|             |                                  |  | TITLE : DISTRIBUTION DESIGN & CONSTRUCTION STANDARD |                  |
|             |                                  | DOUBLE POLE ASSEMBLY FOR 12 M TELESCOPIC POLE WITH GROUNDWIRE (11 kV & 33kV) |   |                  |
| DESIGNED BY | NAME                             | DATE   | DRAWING NO. BPC-DDCS-2015-36/2                      | REVISION<br>2015 |
| CHECKED BY  |                                  |  |   |                  |
| APPROVED BY |                                  |  |   |                  |



ANGLE FOR TOP CROSS BRACING SUPPORT (ISA 65x65x6) - 1 NO

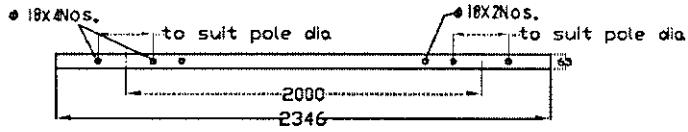

ANGLE FOR LOWER CROSS BRACING SUPPORT (ISA 65x65x6) - 1 NO

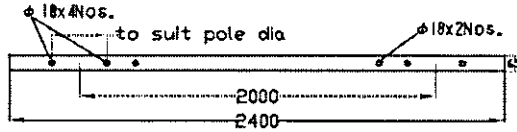

ANGLE FOR CROSS BRACING (ISA 65 x 65 x 6) - 2 NOS



SHIELDING ARRANGEMENT ON DOUBLE POLE STRUCTURES

SHIELD WIRE CHANNEL

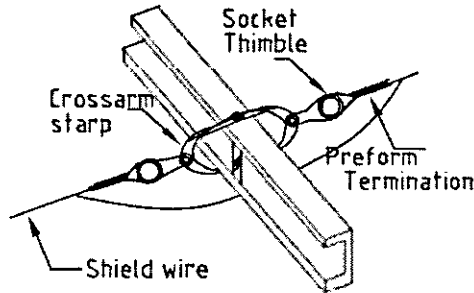

NOTES

1. DIMENSIONS AS SHOWN ARE IN mm.
2. DRAWING IS NOT TO SCALE.
3. LENGTH OF THE CROSS BRACING ANGLE SHALL BE DESIGNED BY THE SUPPLIER

|  |   |               |
|--|---|---------------|
|  <p><b>BHUTAN POWER CORPORATION LIMITED</b></p> | ENGINEERING DESIGN & CONTRACTS DEPARTMENT           |               |
|  | TITLE : DISTRIBUTION DESIGN & CONSTRUCTION STANDARD |               |
| DOUBLE POLE ASSEMBLY FOR 12 M TELESCOPIC POLE WITH GROUNDWIRE (11 KV & 33KV)   |   |               |
| DESIGNED BY  | NAME  | DATE          |
| CHECKED BY   |   |               |
| APPROVED BY  |   |               |
| DRAWING NO. BPC-DDCS-2015-36/3   |   | REVISION 2015 |

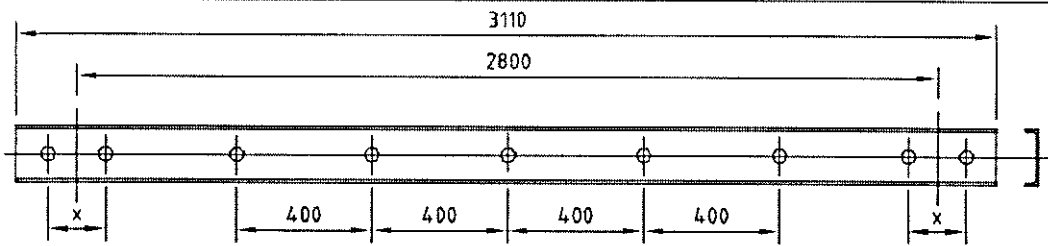

"x" TO SUIT OD OF POLE,

EQUIPMENT SUPPORTS,  
CH 75x40 (3NOS)

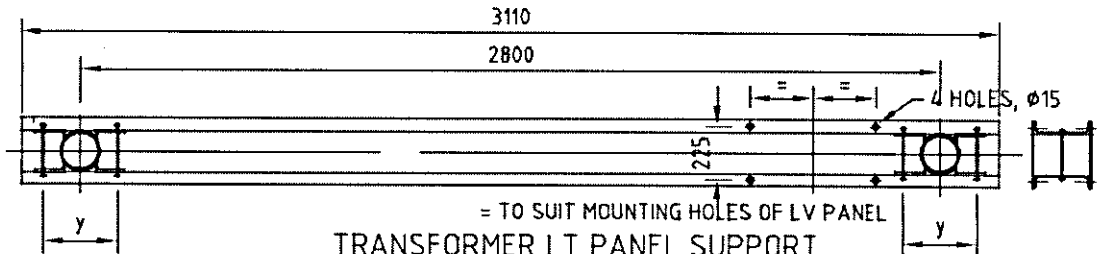

"y" TO SUIT NOM 165 OD OF POLE,

= TO SUIT MOUNTING HOLES OF LV PANEL  
TRANSFORMER LT PANEL SUPPORT  
CH 100x50

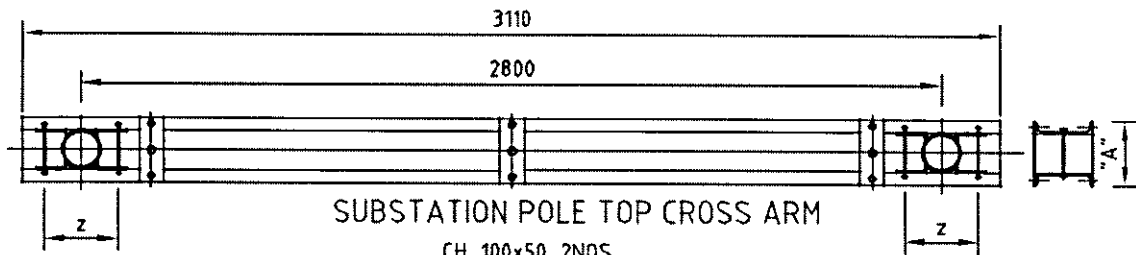

"z" TO SUIT OD OF POLE

SUBSTATION POLE TOP CROSS ARM  
CH 100x50 2NOS

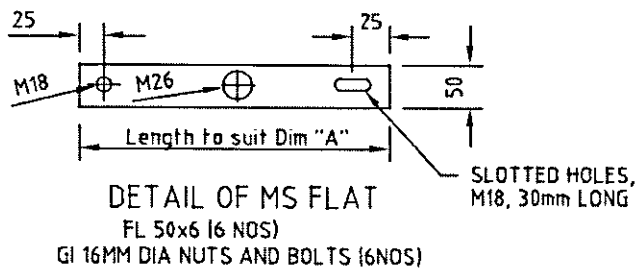

DETAIL OF MS FLAT  
FL 50x6 (6 NOS)

GI 16MM DIA NUTS AND BOLTS (6NOS)

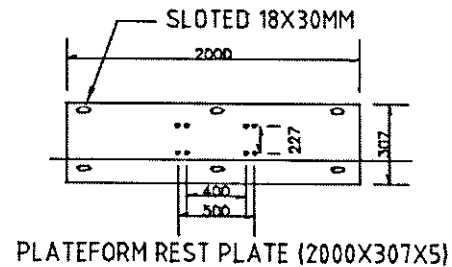

PLATFORM REST PLATE (2000X307X5)

NOTES

1. DIMENSIONS AS SHOWN ARE IN mm.
2. DRAWING IS NOT TO SCALE.
3. TRANSFORMER LT PANEL SUPPORT REQUIRE ONLY FOR 125kVA TRANSFORMERS
4. GENERAL ARRANGEMENT OF SUBSTATION BE REFERRED FROM DRAWING NO. BPC-DDCS-(9 TO 11)

|   |                                  |  |   |  |                  |  |             |  |
|---|----------------------------------|--|---|--|------------------|--|-------------|--|
|  | BHUTAN POWER CORPORATION LIMITED |  | ENGINEERING DESIGN & CONTRACTS DEPARTMENT   |  |                  |  |             |  |
|   |                                  |  | DISTRIBUTION DESIGN & CONSTRUCTION STANDARD |  |                  |  |             |  |
| POLE MOUNTED SUBSTATION STRUCTURE DETAILS<br>FOR STEEL TUBULAR POLE                 |                                  |  | DRAWING NO. BPC-DDCS-2015-37/1              |  |                  |  |             |  |
|   |                                  |  |   |  | REVISION<br>2015 |  |             |  |
|   |                                  |  |   |  |                  |  | DESIGNATION |  |
|   |                                  |  |   |  |                  |  | DRAFTSMAN   |  |
|   |                                  |  |   |  |                  |  | DESIGNER    |  |
| DESIGN CHECK  |                                  |  |   |  |                  |  |             |  |
| PROJECT MANAGER   |                                  |  |   |  |                  |  |             |  |
| PROJECT DIRECTOR  |                                  |  |   |  |                  |  |             |  |

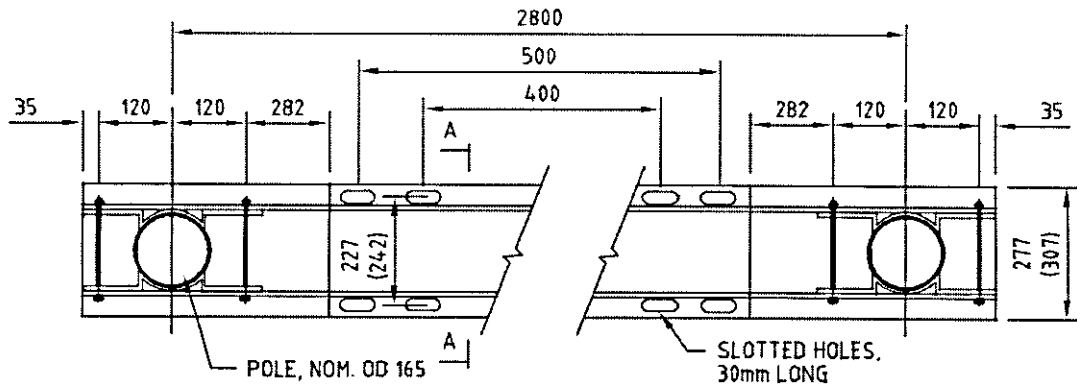

TRANSFORMER PLATFORM (2Nos.)  
ISMC 125x65

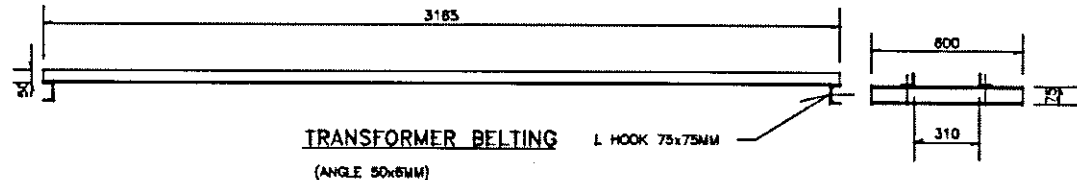

TRANSFORMER BELTING L HOOK 75x75MM  
(ANGLE 50x65MM)

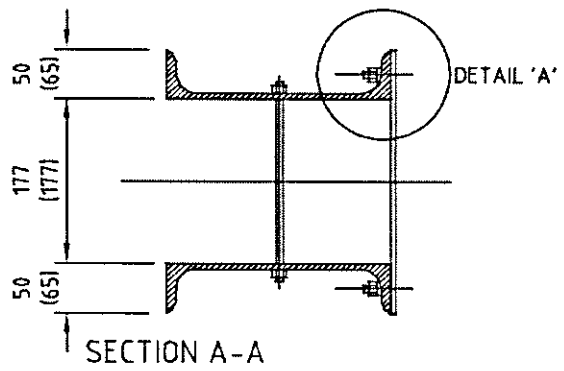

SECTION A-A

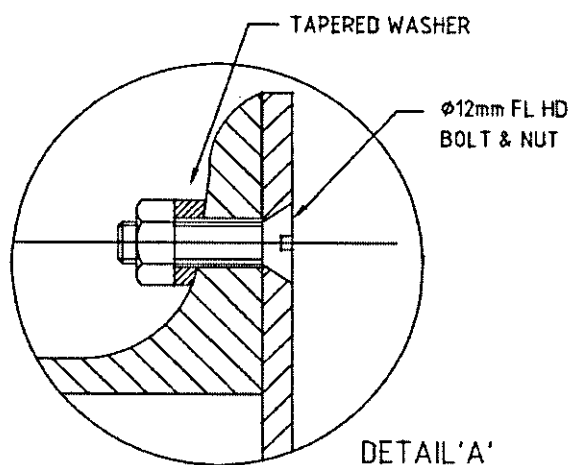

DETAIL 'A'

NOTES

1. DIMENSIONS AS SHOWN ARE IN mm.
2. DRAWING IS NOT TO SCALE.
3. 400 mm hole centre to centre length for 25 kVA and below  
500 mm hole centre to centre length for 63 kVA and above

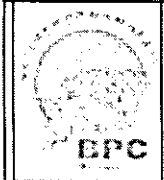

BHUTAN POWER CORPORATION LIMITED

ENGINEERING DESIGN & CONTRACTS DEPARTMENT

DISTRIBUTION DESIGN & CONSTRUCTION STANDARD

33 & 11 kV TRANSFORMER PLATFORM FOR STEEL TUBULAR POLE

| DESIGNATION      | NAME | DATE |
|------------------|------|------|
| DRAFTSMAN        |      |      |
| DESIGNER         |      |      |
| DESIGN CHECK     |      |      |
| PROJECT MANAGER  |      |      |
| PROJECT DIRECTOR |      |      |

DRAWING NO. BPC-DDCS-2015-37/2

REVISION  
2015

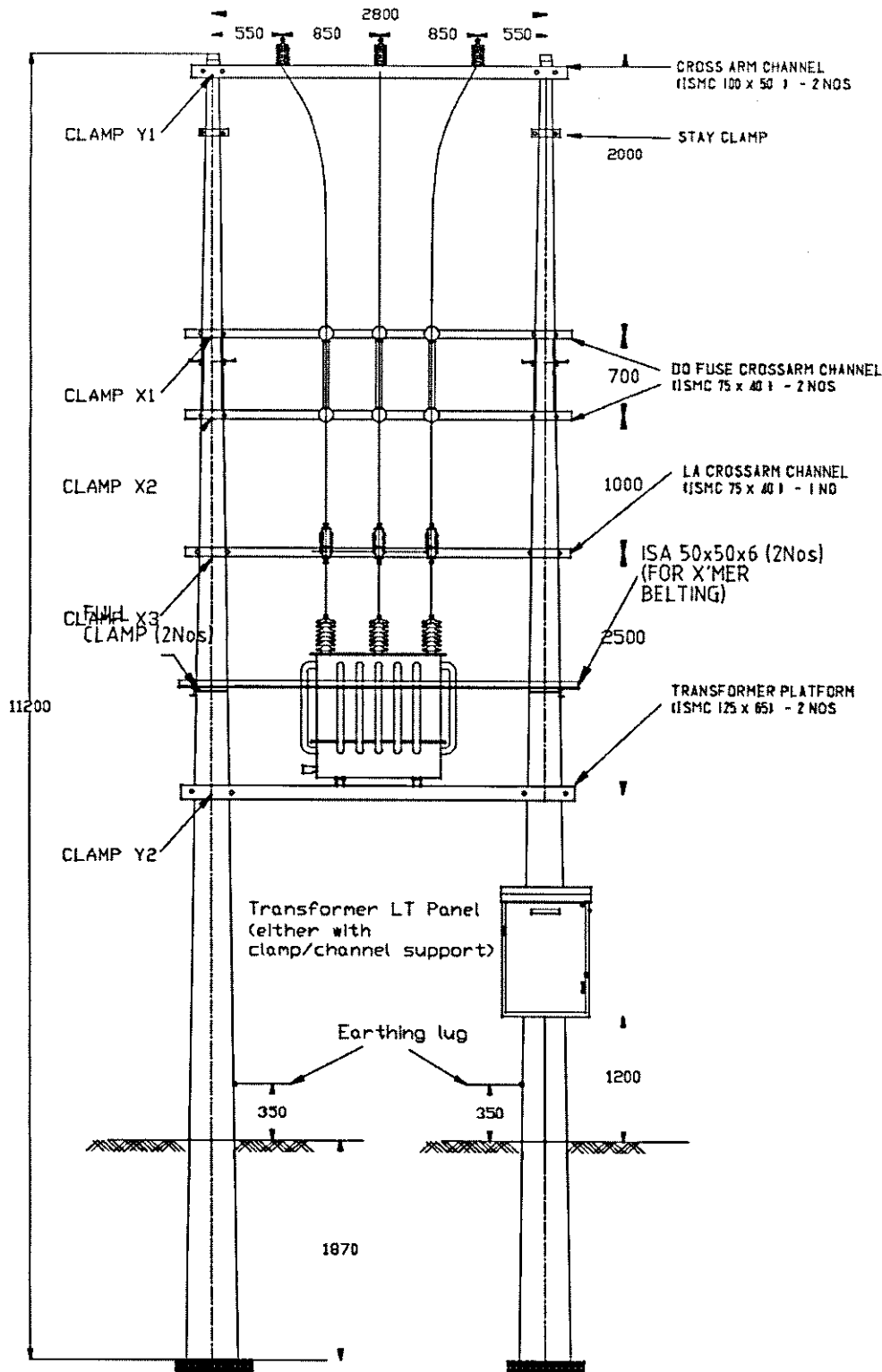

**NOTES**

1. DISTRIBUTION PILLAR MOUNTING CHANNEL ONLY REQUIRE FOR 125 kVA TRANSFORMERS
2. MOUNTING HEIGHT OF THE TOP DO FUSE TO BE ADJUSTED WITHIN 6M FOR USE OF HOT STICK

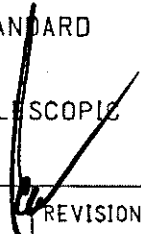
|   |  |  |   |
|---|--|--|---|
|  | <b>BHUTAN POWER CORPORATION LIMITED</b>                | <b>ENGINEERING DESIGN &amp; CONTRACTS DEPARTMENT</b> |   |
|   | <b>DISTRIBUTION DESIGN &amp; CONSTRUCTION STANDARD</b> |  |  |
| <b>SUBSTATION STRUCTURE ASSEMBLY FOR 11.2 M TELESCOPE POLE</b>                      |  |  |   |
| DESIGNED BY   | NAME   | DATE   |   |
| CHECKED BY  |  |  | <b>REVISION 2015</b>  |
| APPROVED BY   |  |  |   |

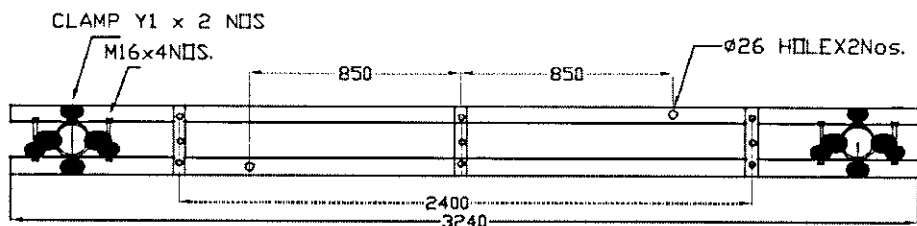

TOP CROSSARM ASSEMBLY

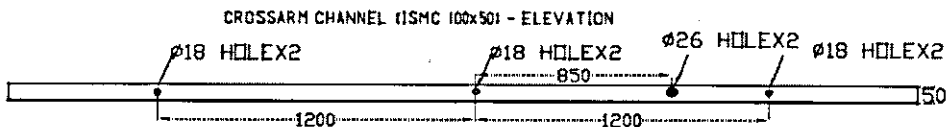

CROSSARM CHANNEL (ISMC 100x50) - PLAN

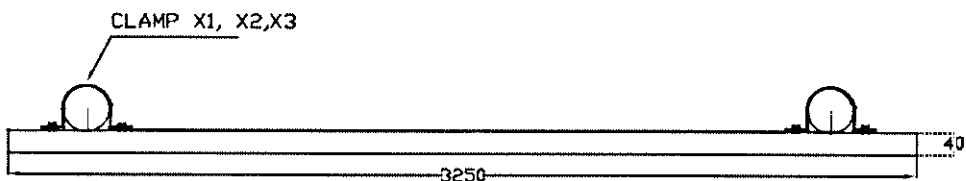

EQUIPMENT CROSSARM CHANNEL ASSEMBLY

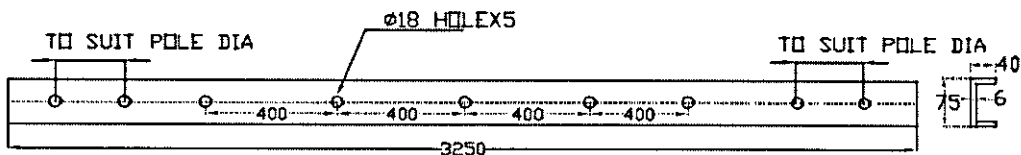

EQUIPMENT CROSSARM CHANNEL (ISMC 75x40) - 3 NOS

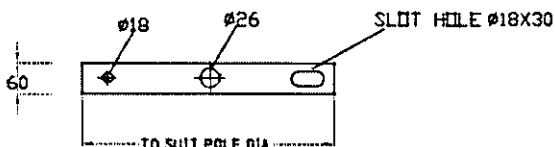

MS TENSION STRAP (60x6) - 6 NOS

NOTES

1. DIMENSIONS AS SHOWN ARE IN mm.
2. DRAWING IS NOT TO SCALE.

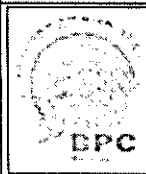

BHUTAN POWER CORPORATION LIMITED

ENGINEERING DESIGN & CONTRACTS DEPARTMENT

TITLE : DISTRIBUTION DESIGN & CONSTRUCTION STANDARD

SUBSTATION (1 or 3 PHASE) STRUCTURE CROSS-ARM ASSEMBLY FOR 11.2M TELESCOPIC POLE

|             | NAME | DATE |
|-------------|------|------|
| DESIGNED BY |      |      |
| CHECKED BY  |      |      |
| APPROVED BY |      |      |

DRAWING NO. BPC-DDCS-2015-38/2

REVISION 2015

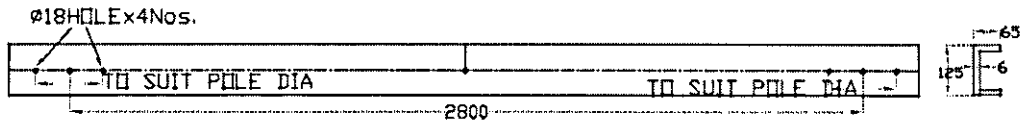
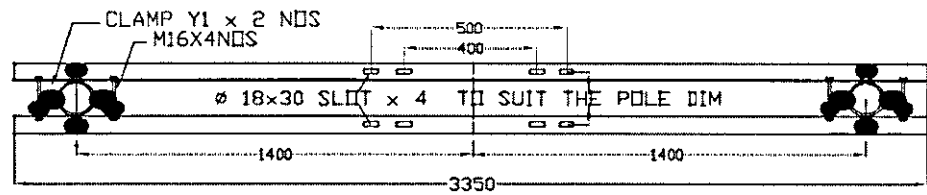

TRANSFORMER SUPPORT CROSSARM CHANNEL (ISMC 125x65) - 2 NOS - ELEVATION

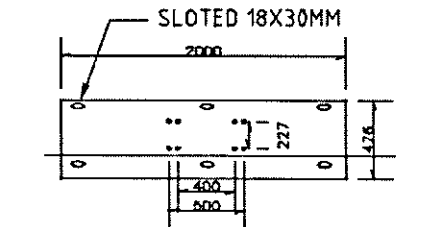
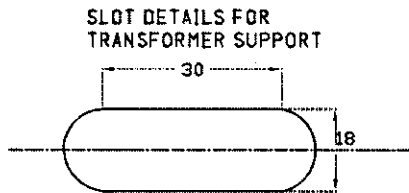
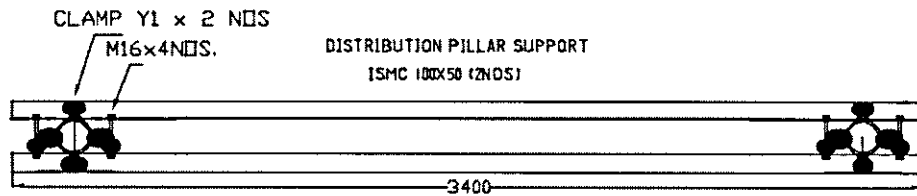
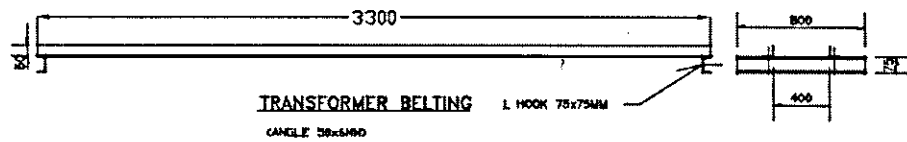

PLATFORM REST PLATE (2000X307X5)

NOTES

1. DIMENSIONS AS SHOWN ARE IN mm.
2. DRAWING IS NOT TO SCALE.
3. The hole centre to hole centre 400mm for trfs upto 25 kVA, 500mm for trfs above 25kVA

|   |   |   |   |      |
|---|---|---|---|------|
|  | <b>BHUTAN POWER CORPORATION LIMITED</b> |   | ENGINEERING DESIGN & CONTRACTS DEPARTMENT           |      |
|   |   |   | TITLE : DISTRIBUTION DESIGN & CONSTRUCTION STANDARD |      |
|   |   | SUBSTATION (1 or 3 PHASE) STRUCTURE CROSS-ARM ASSEMBLY FOR 11.2 M TELESCOPIC POLE |   |      |
| DESIGNED BY   | NAME                                    | DATE  | DRAWING NO. BPC-DDCS-2015-38/3                      |      |
| CHECKED BY  |   |   |   |      |
| APPROVED BY   |   |   |   |      |
|   |   |   | REVISION  | 2015 |

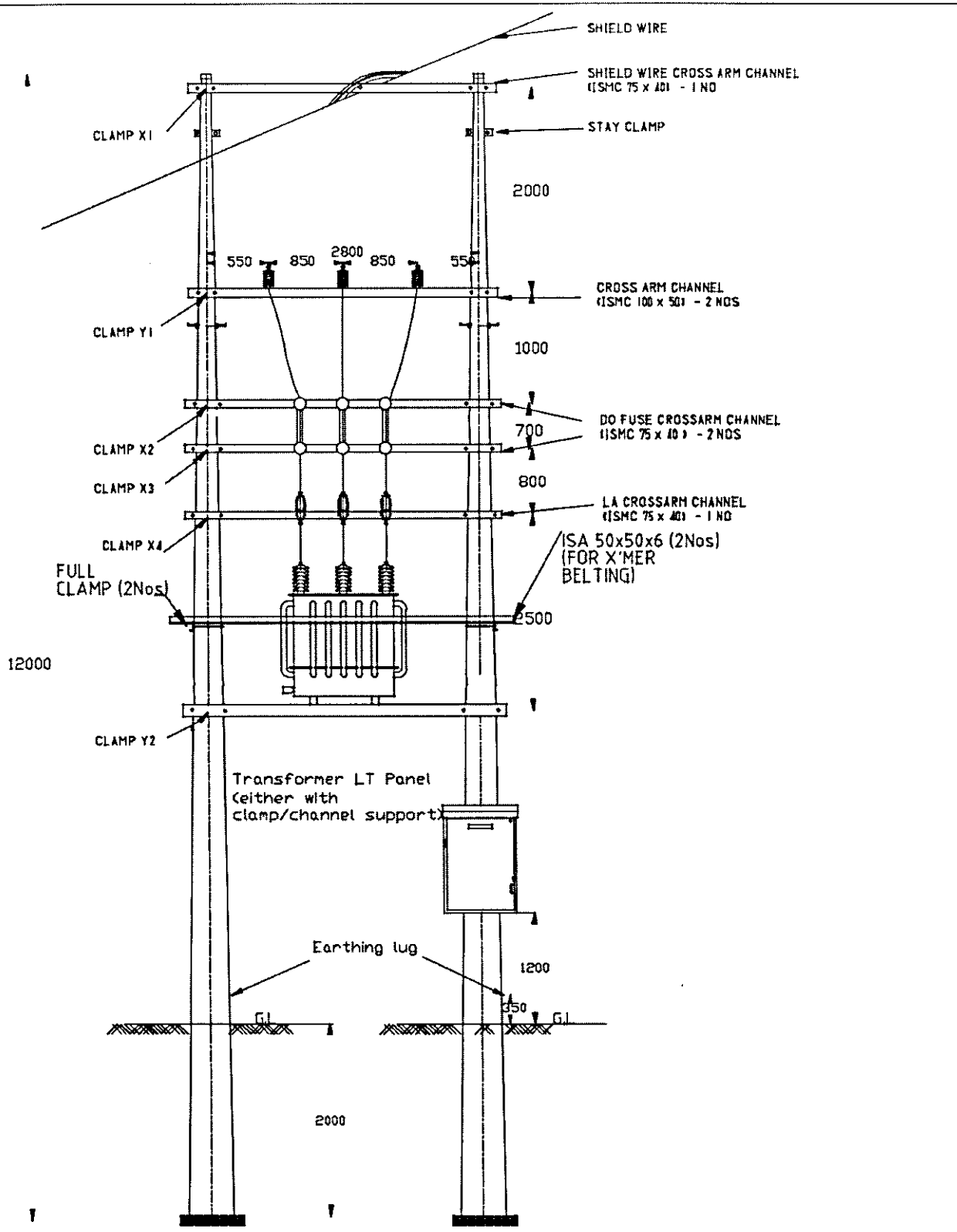

DISTRIBUTION PILLAR MOUNTING CHANNEL ONLY REQUIRE FOR 125 kVA TRANSFORMERS  
 MOUNTING HEIGHT OF THE TOP DO FUSE TO BE ADJUSTED WITHIN 6M FOR USE OF HOT STICK



BHUTAN POWER CORPORATION LIMITED

ENGINEERING DESIGN & CONTRACTS DEPARTMENT

DISTRIBUTION DESIGN & CONSTRUCTION STANDARD

SUBSTATION (3 PHASE) STRUCTURE ASSEMBLY - 12 M  
 TELESCOPIC POLE WITH SHIELDWIRE

| DESIGNED BY | NAME | DATE |
|-------------|------|------|
| CHECKED BY  |      |      |
| APPROVED BY |      |      |

DRAWING NO. BPC-DDCS-2015-39/1

REVISION  
2015

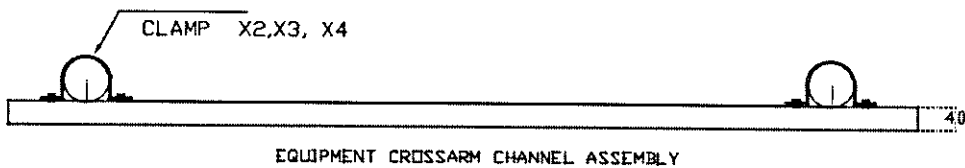
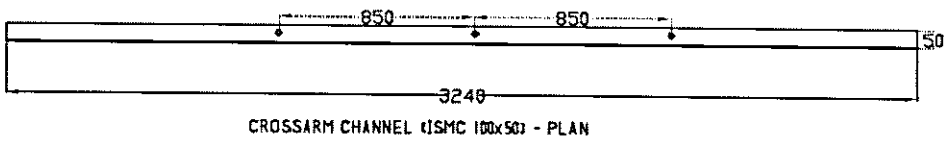
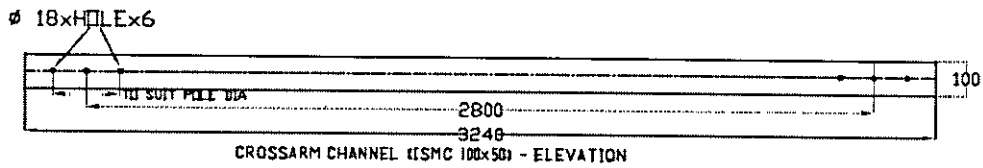
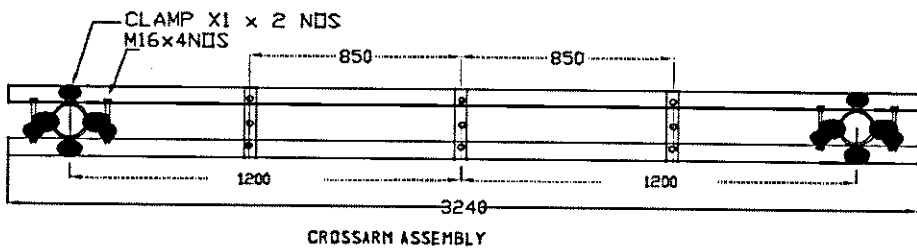
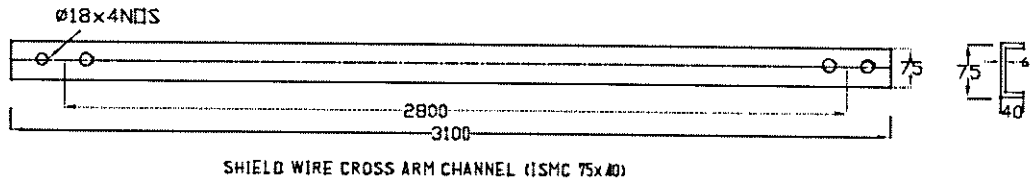
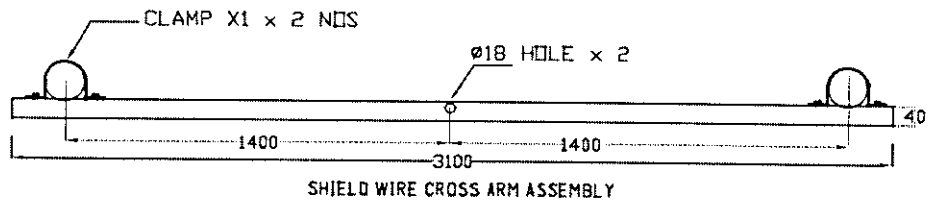

**NOTES**

1. DIMENSIONS AS SHOWN ARE IN mm.
2. DRAWING IS NOT TO SCALE.

|  |   |               |
|--|---|---------------|
|  <p><b>BHUTAN POWER CORPORATION LIMITED</b></p> | ENGINEERING DESIGN & CONTRACTS DEPARTMENT   |               |
|  | DISTRIBUTION DESIGN & CONSTRUCTION STANDARD |               |
| SUBSTATION (1 or 3 PHASE) STRUCTURE CROSS-ARM ASSEMBLY FOR 12M TELESCOPIC POLE WITH SHIELD WIRE                                    |   |               |
| DESIGNED BY  | NAME  | DATE          |
| CHECKED BY   |   |               |
| APPROVED BY  |   |               |
| DRAWING NO. BPC-DDCS-2015-39/2   |   | REVISION 2015 |



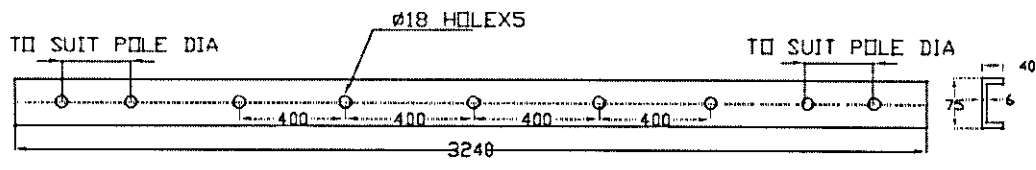

EQUIPMENT CROSSARM CHANNEL (ISMC 75x40x6) - 3 NOS

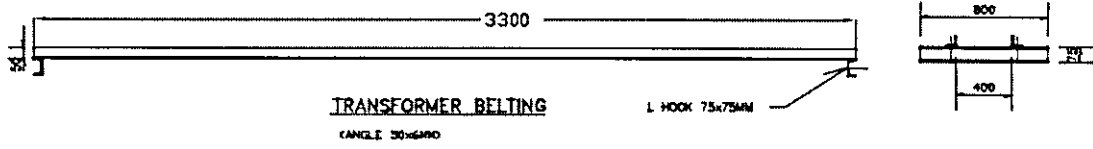

TRANSFORMER BELTING  
ANGLE 50x600

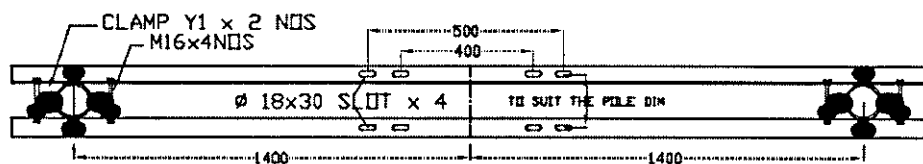

TRANSFORMER SUPPORT CROSSARM CHANNEL (ISMC 125x65x6) - 2 NOS - ELEVATION

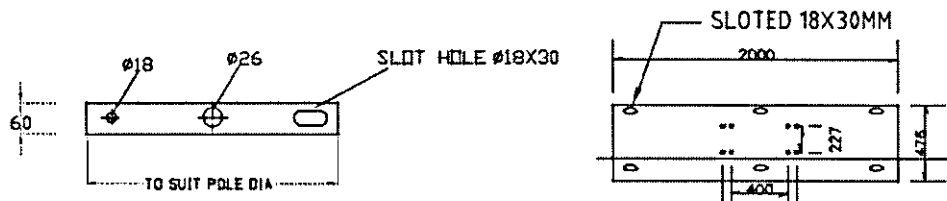
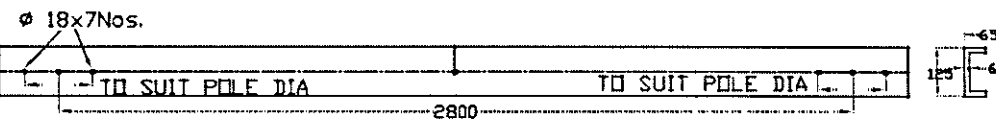

MS TENSION STRAP (60x6) - 6 NOS

PLATFORM REST PLATE (2000X307X5)

SLOT DETAILS

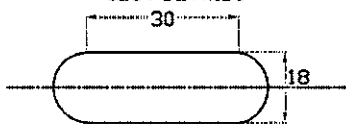

NOTES

1. DIMENSIONS AS SHOWN ARE IN mm.
2. DRAWING IS NOT TO SCALE.
3. The hole centre to hole centre 400mm for trfs upto 25 kVA, 500mm for trfs above 63 kVA

|   |   |                                       |  |                       |  |
|---|---|---------------------------------------|--|-----------------------|--|
|                      | <b>BHUTAN POWER CORPORATION LIMITED</b> |                                       | <b>ENGINEERING DESIGN &amp; CONTRACTS DEPARTMENT</b>   |                       |  |
|   |   |                                       | <b>DISTRIBUTION DESIGN &amp; CONSTRUCTION STANDARD</b> |                       |  |
| <b>SUBSTATION (1 or 3 PHASE) STRUCTURE CROSS-ARM ASSEMBLY FOR 12 M TELESCOPIC POLE WITH SHIELD WIRE</b> |   | <b>DRAWING NO. BPC-DDCS-2015-39/3</b> |  | <b>REVISION 03/15</b> |  |
| DESIGNED BY   | NAME                                    | DATE                                  |  |                       |  |
| CHECKED BY  |   |                                       |  |                       |  |
| APPROVED BY   |   |                                       |  |                       |  |

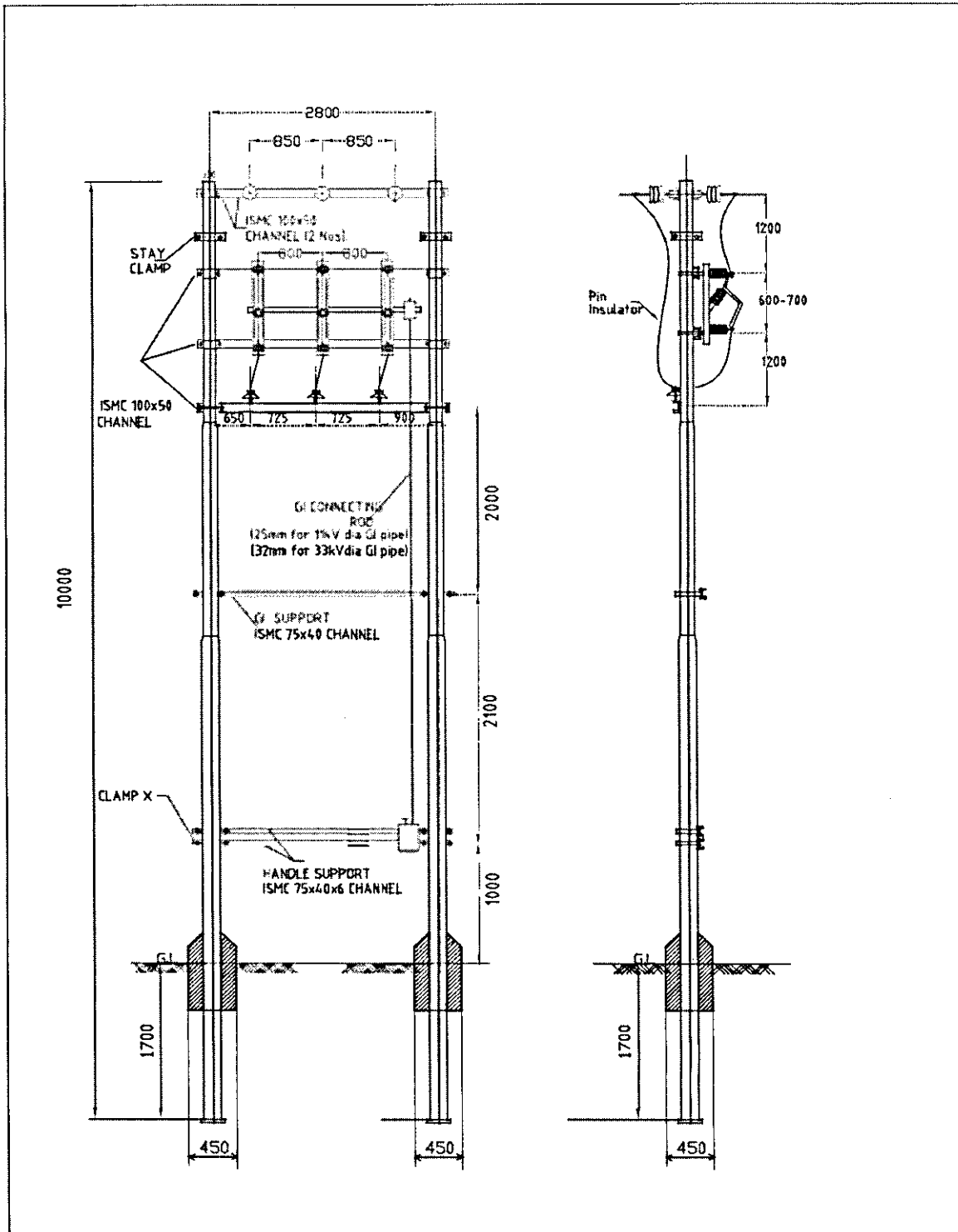

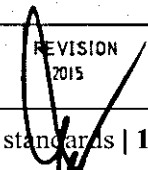
|   |   |                                       |   |  |
|---|---|---------------------------------------|---|--|
|  | <b>BHUTAN POWER CORPORATION LIMITED</b> |                                       | ENGINEERING DESIGN & CONTRACTS DEPARTMENT   |  |
|   |   |                                       | DISTRIBUTION DESIGN & CONSTRUCTION STANDARD   |  |
|   |   | 11 & 33kV AIRBREAK SWITCH ARRANGEMENT |   |  |
|   |   | STEEL TUBULAR POLE                    |   |  |
| DESIGNED BY   | NAME                                    | DATE                                  | DRAWING NO. BPC-DDCS-2015-40/1 <div style="float: right;">           REVISION<br/>2015            </div> |  |
| CHECKED BY  |   |                                       |   |  |
| APPROVED BY   |   |                                       |   |  |

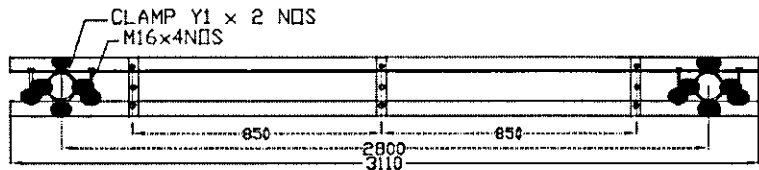

CROSSARM ASSEMBLY

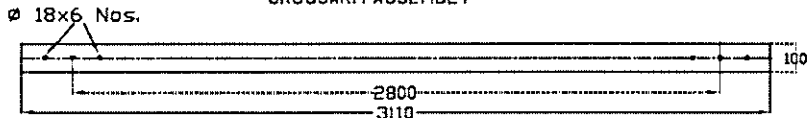

CROSSARM CHANNEL (ISMC 100x50) - ELEVATION



CROSSARM CHANNEL (ISMC 100x50) - PLAN

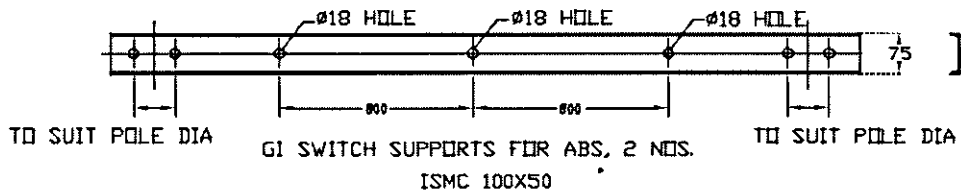

GI SWITCH SUPPORTS FOR ABS, 2 NOS.  
ISMC 100x50

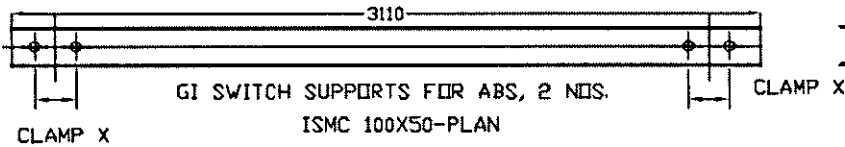

GI SWITCH SUPPORTS FOR ABS, 2 NOS.  
ISMC 100x50-PLAN

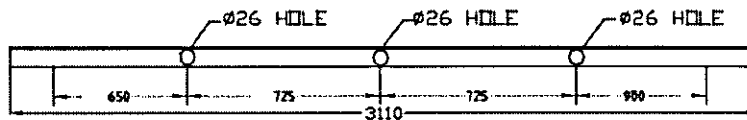

PIN INSULATOR SUPPORTS, 1 NO.  
ISMC 100x50

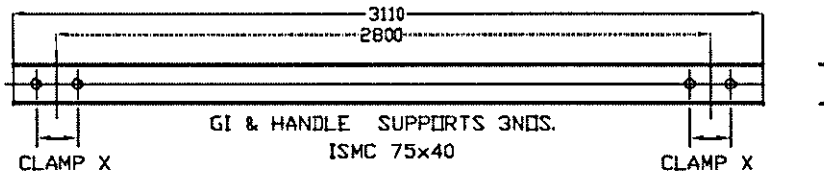

GI & HANDLE SUPPORTS 3 NOS.  
ISMC 75x40

NOTES

1. DIMENSIONS AS SHOWN ARE IN mm.
2. ALL HOLES ARE 18mm AND ALL BOLTS TO BE 16mm.



BHUTAN POWER CORPORATION LIMITED

ENGINEERING DESIGN & CONTRACTS DEPARTMENT

DISTRIBUTION DESIGN & CONSTRUCTION STANDARD

AIRBREAK SWITCH CROSS-ARM ASSEMBLY FOR STEEL TUBULAR POLE

|             | NAME | DATE |
|-------------|------|------|
| DESIGNED BY |      |      |
| CHECKED BY  |      |      |
| APPROVED BY |      |      |

DRAWING NO. BPC-DDCS-2015-40/2

REVISION  
2015

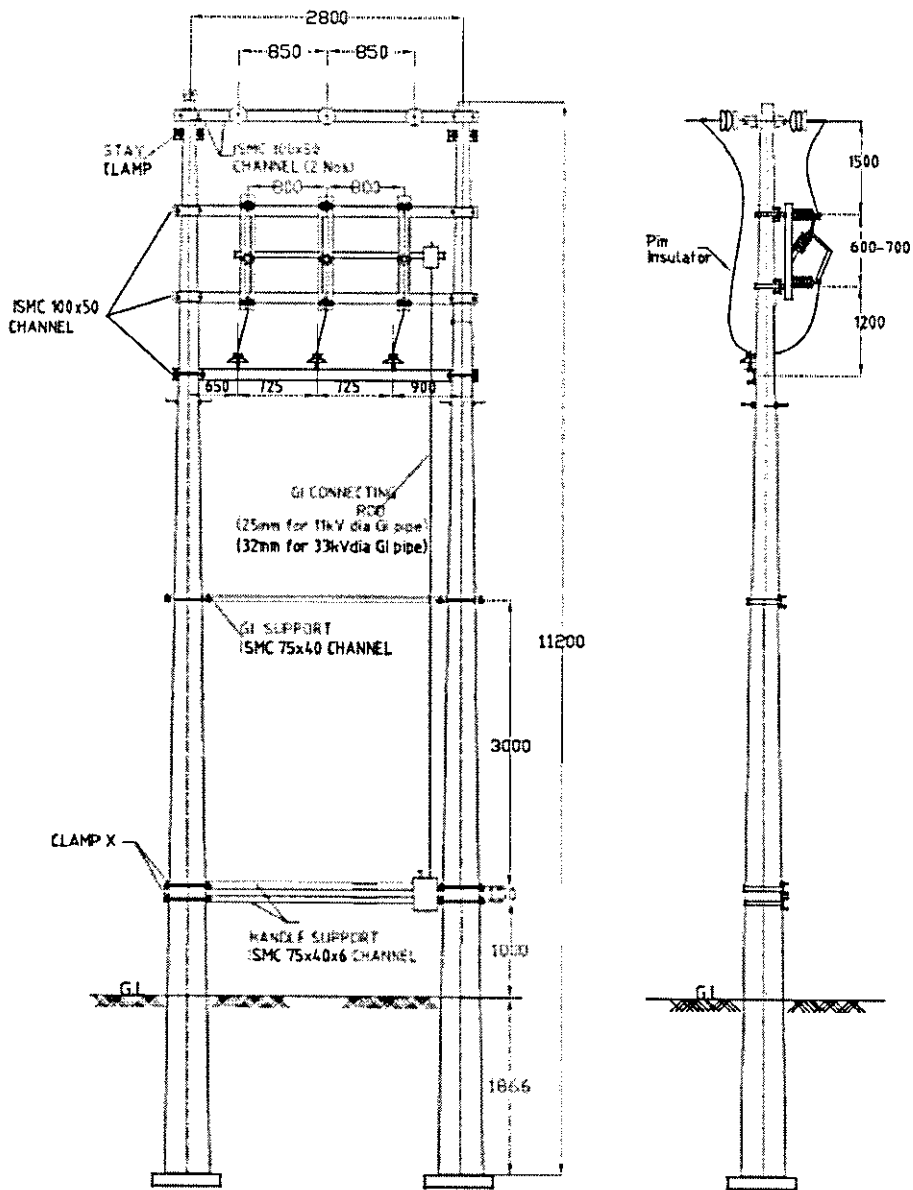

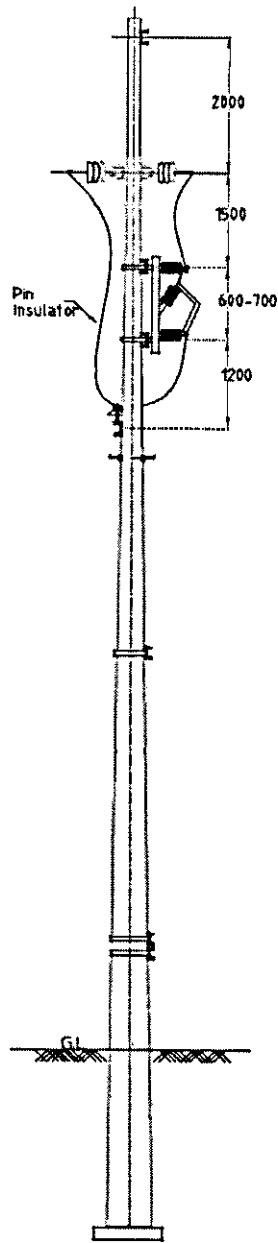
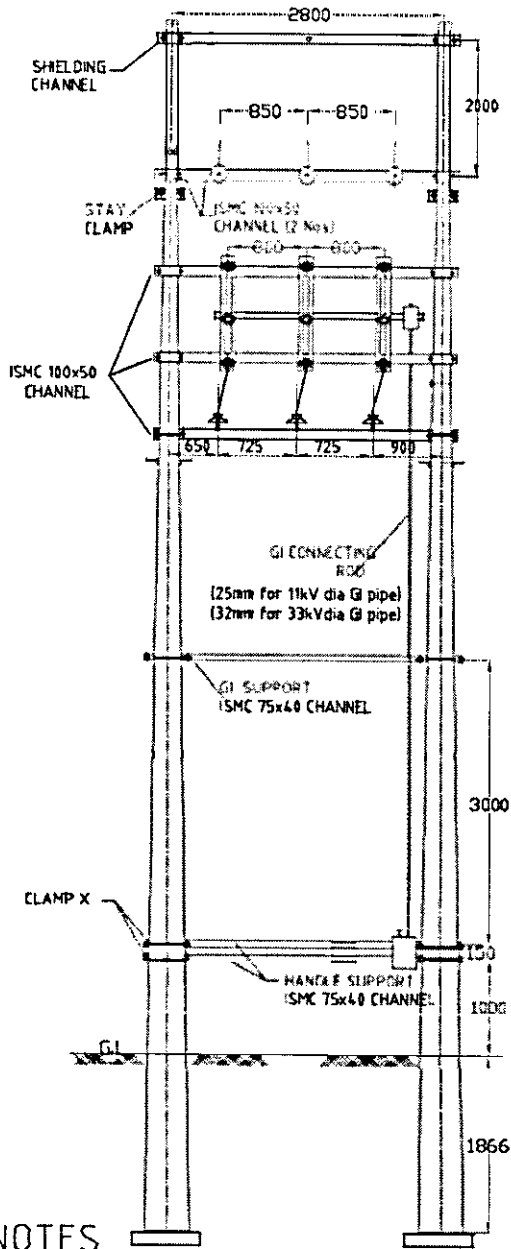

|   |   |  |  |  |
|---|---|--|--|--|
|  | <b>BHUTAN POWER CORPORATION LIMITED</b> |  | <b>ENGINEERING DESIGN &amp; CONTRACTS DEPARTMENT</b>   |  |
|   |   |  | <b>DISTRIBUTION DESIGN &amp; CONSTRUCTION STANDARD</b> |  |
|   |   | <b>11 &amp; 33kV AIRBREAK SWITCH ARRANGEMENT-11.2M</b> |  |  |
|   |   | <b>TELESCOPIC POLES</b>                                |  |  |
| DESIGNED BY   | NAME                                    | DATE   | DRAWING NO. BPC-DDCS-2015-41/1                         |  |
| CHECKED BY  |   |  |  |  |
| APPROVED BY   |   |  |  |  |
|   |   |  | REVISION<br>2815                                       |  |



**NOTES**

1. DIMENSIONS AS SHOWN ARE IN mm.
2. ALL HOLES ARE 18mm AND ALL BOLTS TO BE 16mm.

|   |   |   |  |   |
|---|---|---|--|---|
| <br><b>BPC</b> | <b>BHUTAN POWER CORPORATION LIMITED</b> |   | <b>ENGINEERING DESIGN &amp; CONTRACTS DEPARTMENT</b>   |   |
|   |   |   | <b>DISTRIBUTION DESIGN &amp; CONSTRUCTION STANDARD</b> |   |
|   |   | <b>33 kV AIRBREAK SWITCH ARRANGEMENT - 12M TELESCOPIC POLES</b> |  |   |
| DESIGNED BY   | NAME                                    | DATE  | DRAWING NO. BPC-DOCS-2015-41/2                         |   |
| CHECKED BY  |   |   |  |   |
| APPROVED BY   |   |   |  |   |
|   |   |   | REVISION   |  |

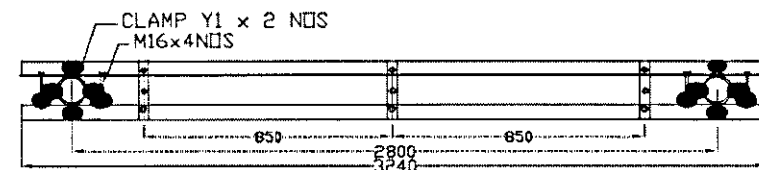

CROSSARM ASSEMBLY

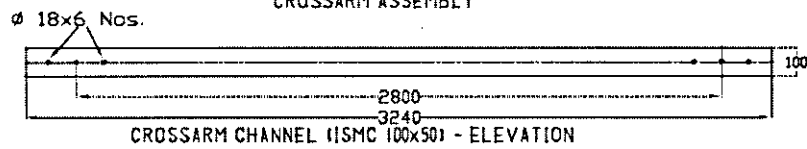

CROSSARM CHANNEL (ISM 100x50) - ELEVATION

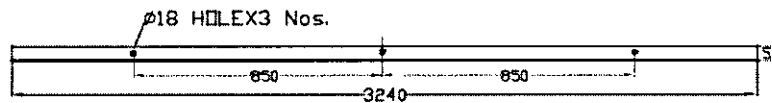

CROSSARM CHANNEL (ISM 100x50) - PLAN

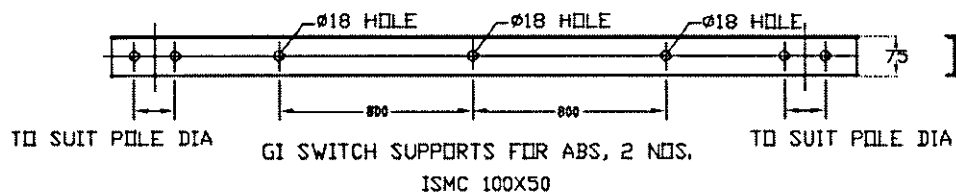

GI SWITCH SUPPORTS FOR ABS, 2 NOS.  
ISM 100x50

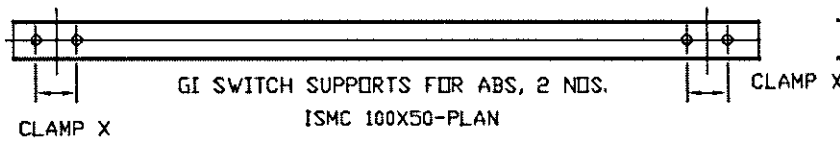

GI SWITCH SUPPORTS FOR ABS, 2 NOS.  
ISM 100x50-PLAN

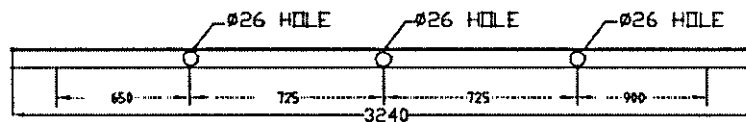

PIN INSULATOR SUPPORTS, 1 NO.  
ISM 100x50

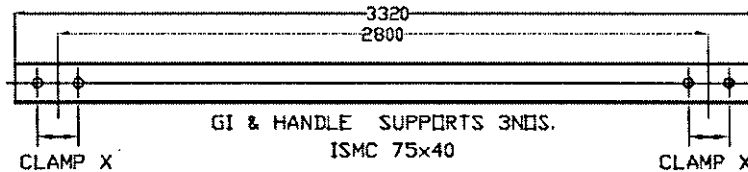

GI & HANDLE SUPPORTS 3 NOS.  
ISM 75x40

NOTES

1. DIMENSIONS AS SHOWN ARE IN mm.
2. ALL HOLES ARE 18mm AND ALL BOLTS TO BE 16mm.
3. SHIELDING ASSEMBLY FOR 12M POLE TO BE SAME FOR ALL

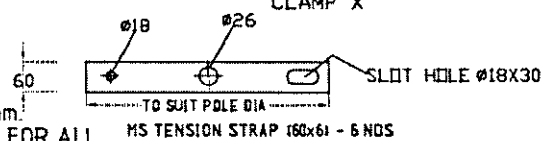

|   | <b>BHUTAN POWER CORPORATION LIMITED</b> |             | <b>ENGINEERING DESIGN &amp; CONTRACTS DEPARTMENT</b>   |      |            |  |  |             |  |  |   |  |
|--|---|-------------|--|------|------------|--|--|-------------|--|--|---|--|
|  |   |             | <b>DISTRIBUTION DESIGN &amp; CONSTRUCTION STANDARD</b> |      |            |  |  |             |  |  |   |  |
| <table border="1"> <thead> <tr> <th>DESIGNED BY</th> <th>NAME</th> <th>DATE</th> </tr> </thead> <tbody> <tr> <td>CHECKED BY</td> <td></td> <td></td> </tr> <tr> <td>APPROVED BY</td> <td></td> <td></td> </tr> </tbody> </table> |   | DESIGNED BY | NAME   | DATE | CHECKED BY |  |  | APPROVED BY |  |  | <b>AIRBREAK SWITCH CROSS-ARM ASSEMBLY<br/>FOR 11.2M &amp; 12M TELESCOPIC POLE</b> |  |
|  |   | DESIGNED BY | NAME   | DATE |            |  |  |             |  |  |   |  |
| CHECKED BY   |   |             |  |      |            |  |  |             |  |  |   |  |
| APPROVED BY  |   |             |  |      |            |  |  |             |  |  |   |  |
| DRAWING NO. BPC-DDCS-2015-41/3   |   |             | REVISION<br>2/5  |      |            |  |  |             |  |  |   |  |

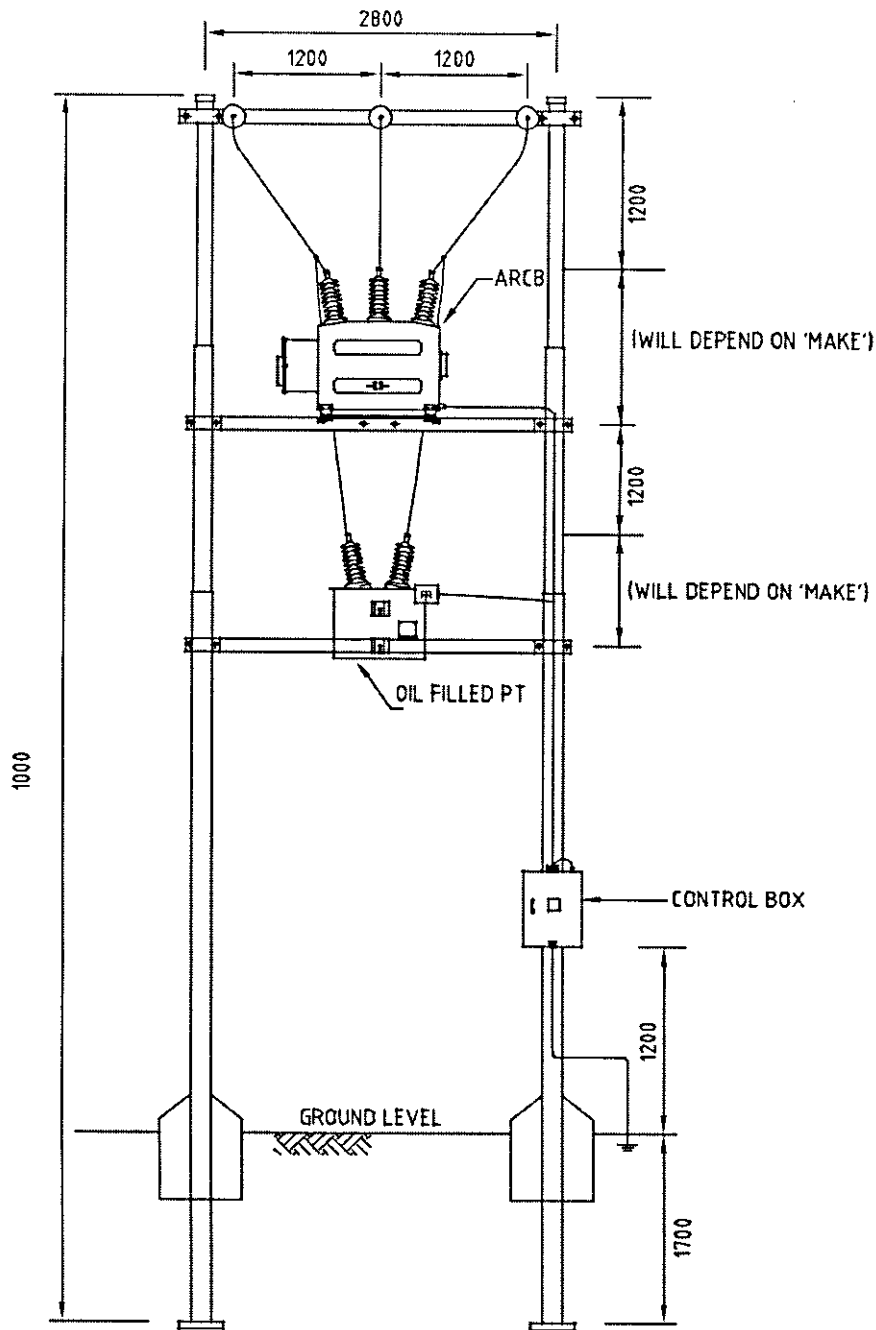

**NOTES**

1. DIMENSIONS AS SHOWN ARE IN mm.
2. DRAWING IS NOT TO SCALE.

|             |   |   |  |      |
|-------------|---|---|--|------|
|             | <b>BHUTAN POWER CORPORATION LIMITED</b> |   | <b>ENGINEERING DESIGN &amp; CONTRACTS DEPARTMENT</b>   |      |
|             |   |   | <b>DISTRIBUTION DESIGN &amp; CONSTRUCTION STANDARD</b> |      |
|             |   | <b>TYPICAL ARCB ARRANGEMENT ON STEEL TUBULAR POLE</b> |  |      |
| DESIGNED BY | NAME                                    | DATE  | DRAWING NO. BPC-DDCS-2015-42/1                         |      |
| CHECKED BY  |   |   |  |      |
| APPROVED BY |   |   |  |      |
|             |   |   | REVISION   | 2015 |

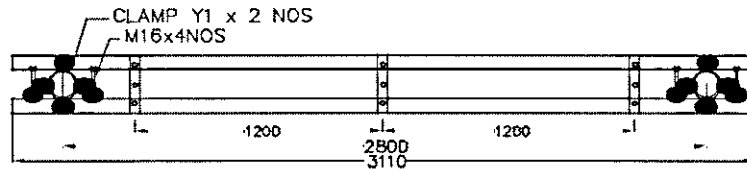

CROSSARM ASSEMBLY

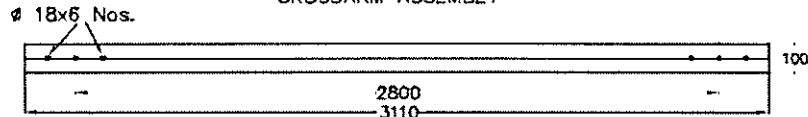

CROSSARM CHANNEL (ISMC 100x50) - ELEVATION



CROSSARM CHANNEL (ISMC 100x50) - PLAN

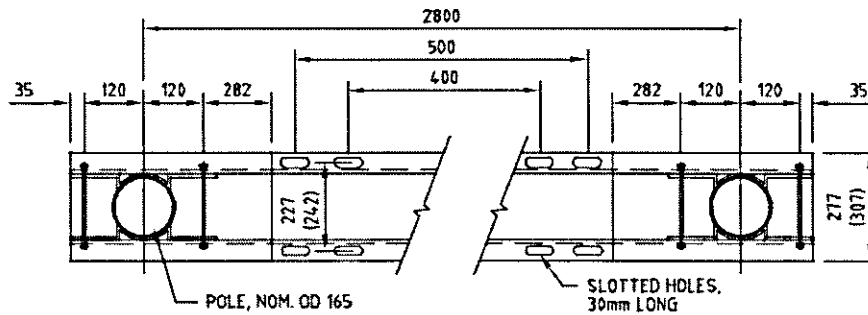

ARCB & PT PLATFORM (2Nos.)  
ISMC 125x65

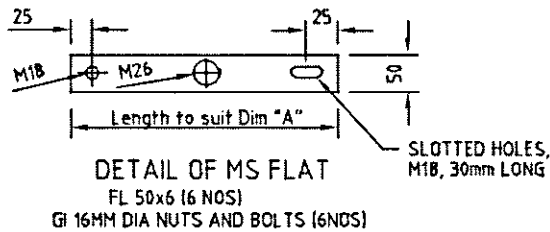

DETAIL OF MS FLAT

FL 50x6 16 NOS)  
GI 16MM DIA NUTS AND BOLTS (6NOS)

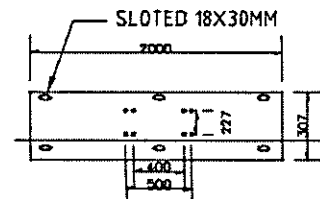

PLATFORM REST PLATE (2000X307X5)

NOTES

1. DIMENSIONS AS SHOWN ARE IN mm.  
ALL HOLES ARE 18mm AND ALL BOLTS TO BE 16mm.  
DRAWING IS NOT TO SCALE.

|   |   |      |   |  |  |
|---|---|------|---|--|--|
|  | <p>BHUTAN POWER CORPORATION LIMITED</p> |      | ENGINEERING DESIGN & CONTRACTS DEPARTMENT   |  |  |
|   |   |      | DISTRIBUTION DESIGN & CONSTRUCTION STANDARD |  |  |
| DESIGNED BY   |   | NAME | DATE  | CROSS-ARM ASSEMBLY FOR MOUNTING ARCB ON STEEL TUBULAR POLE |  |
| CHECKED BY  |   |      |   | DRAWING NO. BPC-DDCS-2015-42/2<br>REVISION 2015            |  |
| APPROVED BY   |   |      |   |  |  |



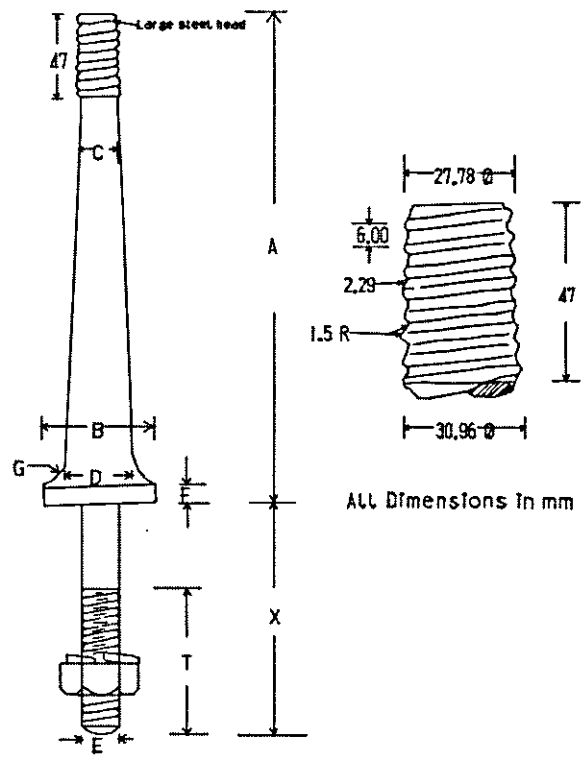
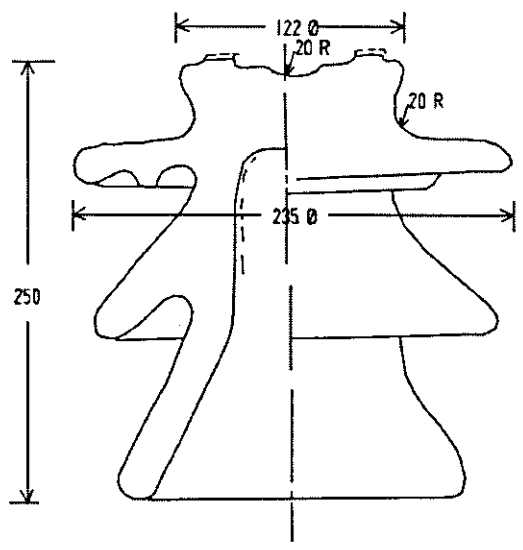

Specification no. IS 2486 (Part II) 1974  
 Min. Failing Load.....1080 kg

| A   | B  | C  | D  | E  | F  | G  | T   | X   |
|-----|----|----|----|----|----|----|-----|-----|
| mm  | mm | mm | mm | mm | mm | mm | mm  | mm  |
| 300 | 67 | 27 | 44 | 24 | 6  | 12 | 100 | 150 |

**TECHNICAL DETAILS:**

- (a) Highest System Voltage ..... 36kV (rms)
- (b) Wet Power Frequency withstand Test ..... 75kV (rms)
- (c) Power Frequency Puncture withstand Test ..... 180kV (rms)
- (d) Impulse Voltage withstand Test ..... 170kV (peak)
- (e) Minimum Failing Load ..... 1080 kg

Large Steel Head Pin for 33kV Pin Insulator



BHUTAN POWER CORPORATION LIMITED

ENGINEERING DESIGN & CONTRACTS DEPARTMENT

DISTRIBUTION DESIGN & CONSTRUCTION STANDARD

33kV - 10.8 KN PIN INSULATOR - LARGE HEAD

| DESIGNATION      | NAME | DATE |
|------------------|------|------|
| DRAFTSMAN        |      |      |
| DESIGNER         |      |      |
| DESIGN CHECK     |      |      |
| PROJECT MANAGER  |      |      |
| PROJECT DIRECTOR |      |      |

DRAWING NO. BPC-DDCS-2015-43/1

REVISION  
2015

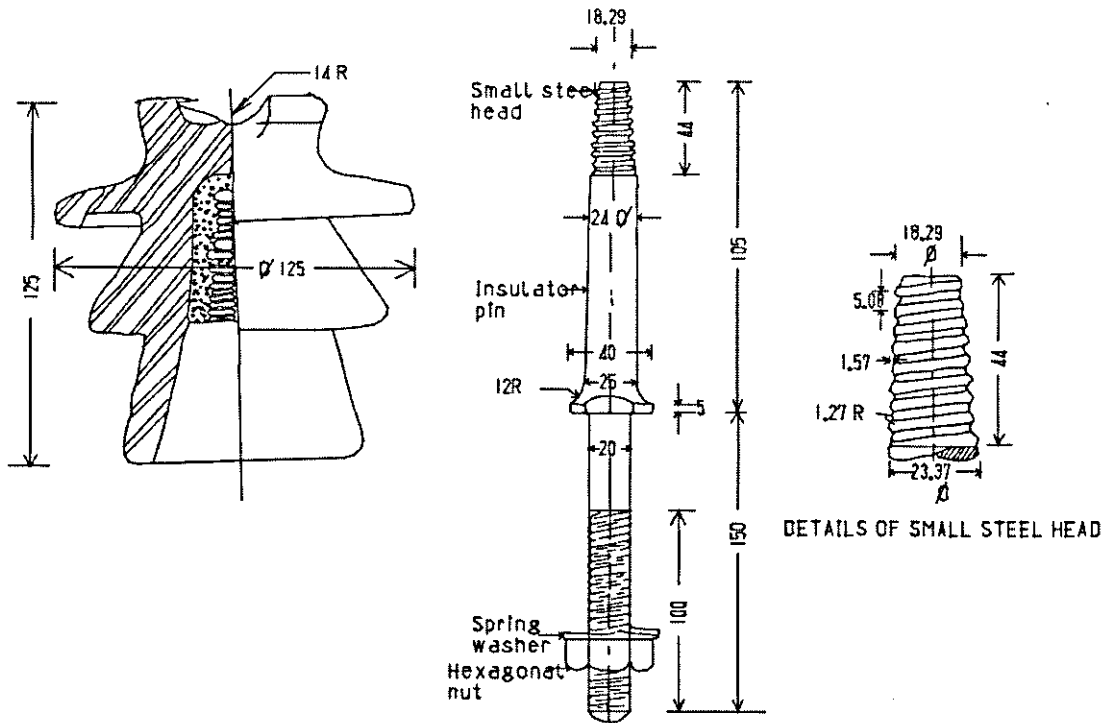

Small Steel Head Pin for 11kV Pin Insulator

Note:

1. Specification no. IS 2486 (Part II)
2. ALL Dimensions in mm
3. Minimum Failing Load 5 kN

|  |  |                  |
|--|--|------------------|
|  <p style="text-align: center;"><b>BHUTAN POWER CORPORATION LIMITED</b></p> | <b>ENGINEERING DESIGN &amp; CONTRACTS DEPARTMENT</b>   |                  |
|  | <b>DISTRIBUTION DESIGN &amp; CONSTRUCTION STANDARD</b> |                  |
| <b>11KV -5KN PIN INSULATOR -SMALL HEAD</b>   |  |                  |
| DESIGNATION  | NAME   | DATE             |
| DRAFTSMAN  |  |                  |
| DESIGNER   |  |                  |
| DESIGN CHECK   |  |                  |
| PROJECT MANAGER  |  |                  |
| PROJECT DIRECTOR   |  |                  |
| DRAWING NO. BPC-DDCS-2015-43/2   |  | REVISION<br>2/15 |

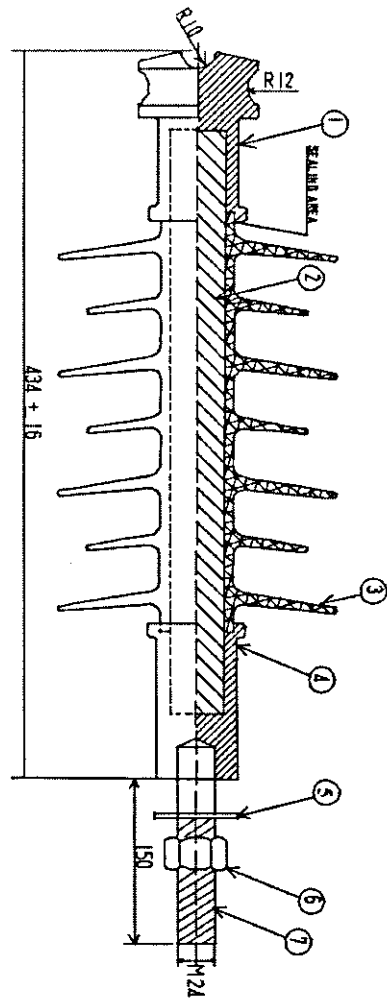

| Sl.no | Description          |
|-------|----------------------|
| 1     | Top Metal Fitting    |
| 2     | Core Rod             |
| 3     | Polymer Housing      |
|       | Bottom Metal Fitting |
| 5     | Plain Washer         |
| 6     | Nut                  |
| 7     | Stud                 |

#### Guaranteed Technical Parameters

1. Min. Creepage Distance : 900 mm
2. Arcing Distance (Approximate) : 320 mm
3. Cantilever Failure Load : 10 kN
4. Nominal System Voltage : 33 kV
5. Highest System Voltage : 36 kV
6. System Frequency : 50 Hz
7. 1 Min. Power Freq. Withstand Voltage (Wet) : 75 kV (rms)
8. Dry Lightning Impulse Withstand Voltage : 170 kVp



BHUTAN POWER CORPORATION LIMITED

ENGINEERING DESIGN & CONTRACTS DEPARTMENT

DISTRIBUTION DESIGN & CONSTRUCTION STANDARD

| DESIGNATION      | NAME | DATE |
|------------------|------|------|
| DRAFTSMAN        |      |      |
| DESIGNER         |      |      |
| DESIGN CHECK     |      |      |
| PROJECT MANAGER  |      |      |
| PROJECT DIRECTOR |      |      |

33kV & 11kV - 10 kN COMPOSITE SILICONE RUBBER PIN INSULATOR

DRAWING NO. BPC-DCCS-2015-44

REVISION  
2015

Porcelain Disc Insulator

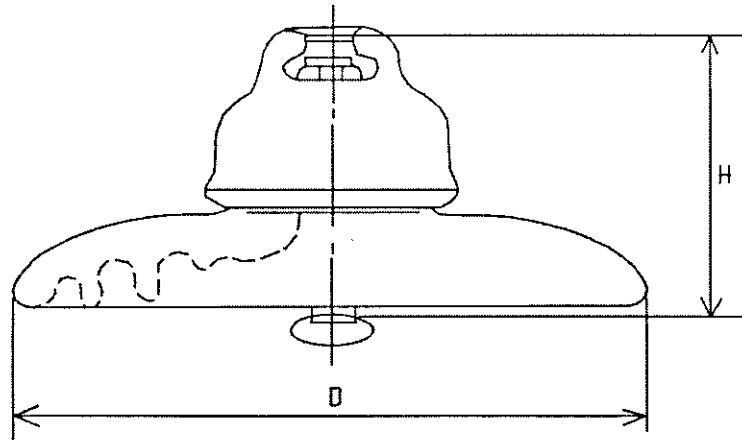

| Item | Dimensions (mm) |     | Rate Failure Load (kN) | Weight (kg) |
|------|-----------------|-----|------------------------|-------------|
|      | D               | H   |                        |             |
| 11kV | 255             | 146 | 70                     | 5.2         |
| 33kV | 255             | 146 | 70                     | 5.2x3       |

33 kV & 11 kV - 70 kN COMPOSITE SILICONE RUBBER LONG ROD INSULATOR

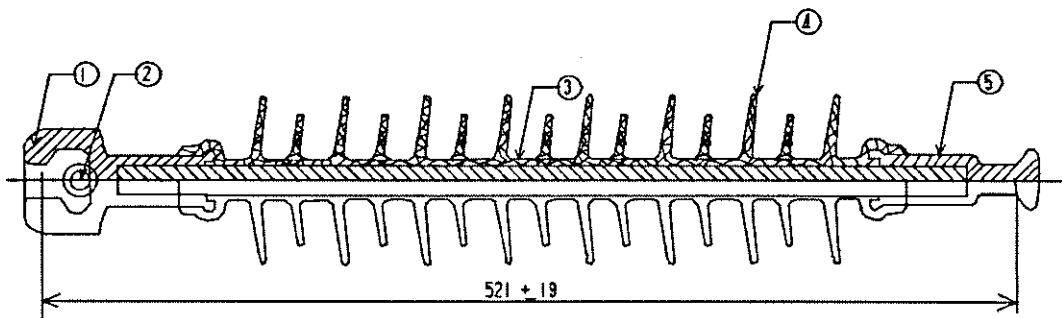

| Sl.no | Description       |
|-------|-------------------|
| 1     | Socket Fitting    |
| 2     | Security clip (R) |
| 3     | Core Rod          |
| 4     | Polymer Housing   |
| 5     | Ball fitting      |

|   |   |               |
|---|---|---------------|
|  <p>BHUTAN POWER CORPORATION LIMITED</p> | ENGINEERING DESIGN & CONTRACTS DEPARTMENT   |               |
|   | DISTRIBUTION DESIGN & CONSTRUCTION STANDARD |               |
| PORCELAIN AND COMPOSITE SILICON RUBBER DISC INSULATOR   |   |               |
| DESIGNATION   | NAME  | DATE          |
| DRAFTSMAN   |   |               |
| DESIGNER  |   |               |
| DESIGN CHECK  |   |               |
| PROJECT MANAGER   |   |               |
| PROJECT DIRECTOR  |   |               |
| DRAWING NO. BPC-DDCS-2015-25  |   | REVISION 2015 |

SINGLE TENSION STRING

33 kV SINGLE TENSION STRING

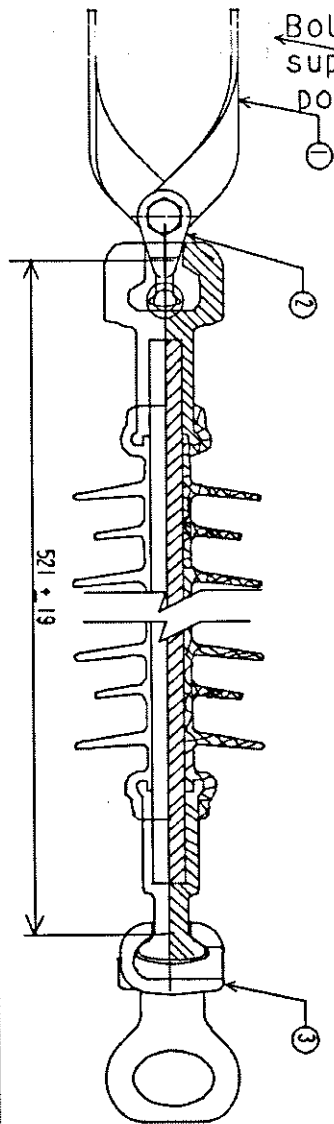

Bolt to be supplied under pole fittings

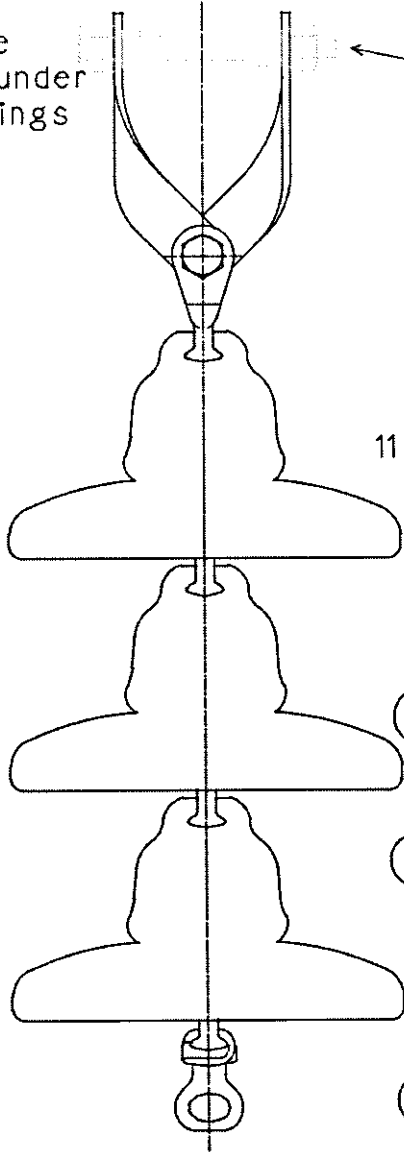

Bolt to be supplied under pole fittings

11 kV SINGLE TENSION STRING

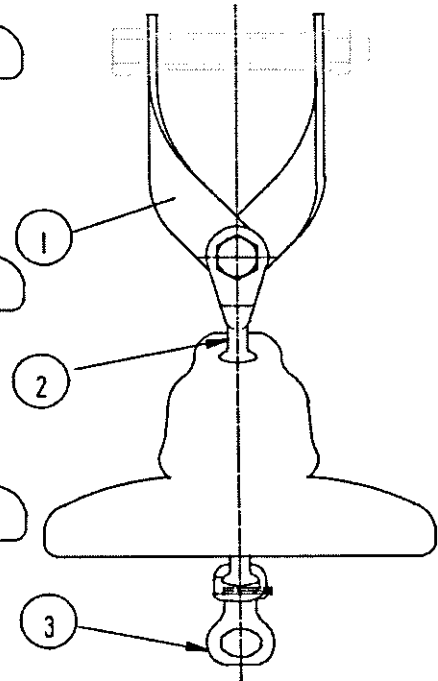

Notes:

1. All fittings shall be galvanised according to relevant standard

| 3    | SOCKET THIMBLE                          | 1   | ALUMINIUM ALLOY |
|------|---|-----|-----------------|
| 2    | BALL EYE                                | 1   | FORGED STEEL    |
| 1    | CROSSARM STRAP (TOGETHER, NOT SEPARATE) | 1   | GALVANISED IRON |
| ITEM | NAME OF ITEM                            | QTY | MATERIAL        |

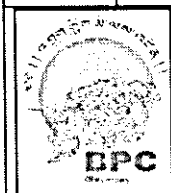

BHUTAN POWER CORPORATION LIMITED

ENGINEERING DESIGN & CONTRACTS DEPARTMENT

DISTRIBUTION DESIGN & CONSTRUCTION STANDARD

ASSEMBLY FOR DISC INSULATOR ARRANGEMENT

| DESIGNATION      | NAME | DATE |
|------------------|------|------|
| DRAFTSMAN        |      |      |
| DESIGNER         |      |      |
| DESIGN CHECK     |      |      |
| PROJECT MANAGER  |      |      |
| PROJECT DIRECTOR |      |      |

DRAWING NO. BPC-DDCS-2015-46

REVISION  
2015

CROSS ARM STRAP

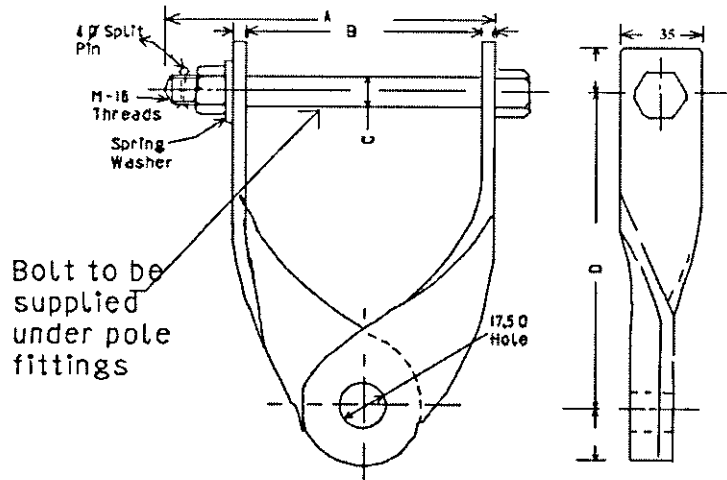

| Dimensions (mm) |     |    |     | Rate Failure Load | Weight |
|-----------------|-----|----|-----|-------------------|--------|
| A               | B   | C  | D   | (kN)              | (kg)   |
| 145             | 100 | 16 | 140 | 70                | -      |

Ball Eye

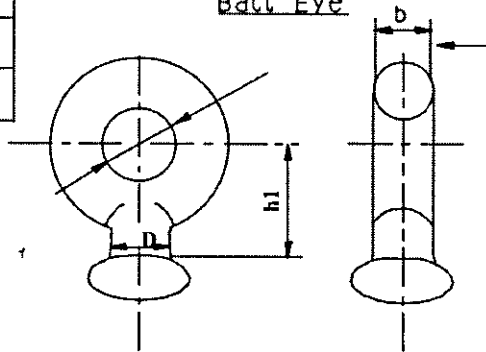

| Dimensions (mm) |    |    |    | Rate Failure Load | Weight |
|-----------------|----|----|----|-------------------|--------|
| D               | h1 | b  | d  | (kN)              | (kg)   |
| 17              | 50 | 16 | 18 | 70                | -      |

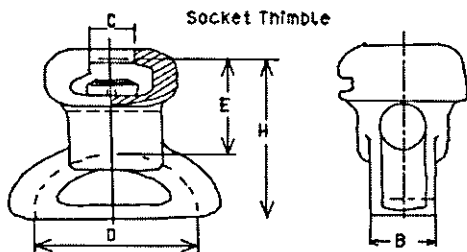

| Dimensions (mm) |      |    |    |    | Rate Failure Load | Weight |
|-----------------|------|----|----|----|-------------------|--------|
| B               | C    | D  | E  | H  | (kN)              | (kg)   |
| 32              | 17.6 | 60 | 60 | 95 | 70                | 1.20   |

Notes:

1. All fittings shall be galvanised according to relevant standard

|   |   |                  |
|---|---|------------------|
|  <p>BHUTAN POWER CORPORATION LIMITED</p> | ENGINEERING DESIGN & CONTRACTS DEPARTMENT   |                  |
|   | DISTRIBUTION DESIGN & CONSTRUCTION STANDARD |                  |
| HARDWARE FITTINGS FOR DISC INSULATOR ARRANGEMENT  |   |                  |
| DESIGNATION   | NAME  | DATE             |
| DRAFTSMAN   |   |                  |
| DESIGNER  |   |                  |
| DESIGN CHECK  |   |                  |
| PROJECT MANAGER   |   |                  |
| PROJECT DIRECTOR  |   |                  |
| DRAWING NO. BPC-DDCS-2015-47  |   | REVISION<br>2015 |

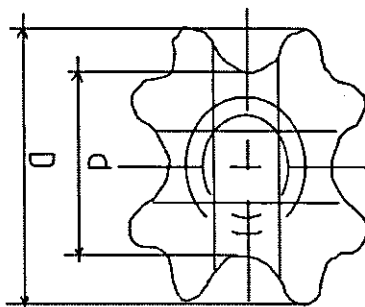
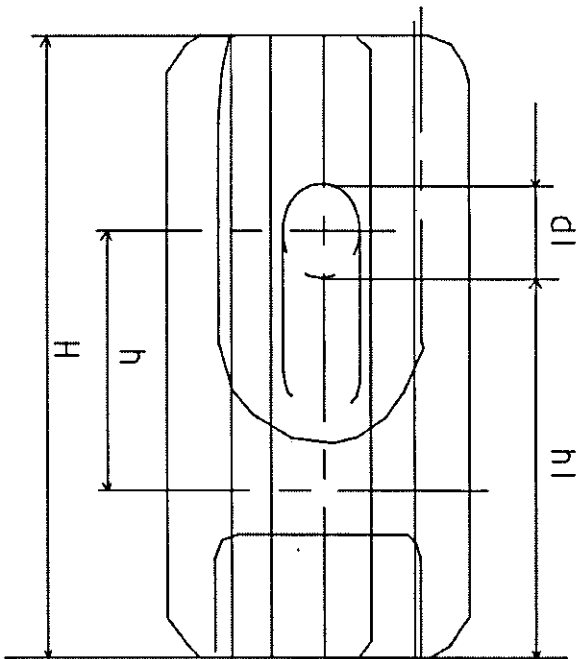

| Item      | Dimensions (mm) |    |    |      |       |      | Rated Failure Load (kN) | Weight (kg) |
|-----------|-----------------|----|----|------|-------|------|-------------------------|-------------|
|           | H               | h  | D  | d    | h1    | d1   |                         |             |
| 11 & 33kV | 171             | 67 | 89 | 60.3 | 114.3 | 25.4 | 89                      | 1.95        |

|  |  |  |  |
|--|--|--|--|
| <br><b>BHUTAN POWER CORPORATION LIMITED</b> |  | <b>ENGINEERING DESIGN &amp; CONTRACTS DEPARTMENT</b>   |  |
| <b>TITLE</b>   |  | <b>NAME</b>  |  |
| <b>DESIGNED BY</b>   |  | <b>DATE</b>  |  |
| <b>CHECKED BY</b>  |  | <b>DISTRIBUTION DESIGN &amp; CONSTRUCTION STANDARD</b> |  |
| <b>APPROVED BY</b>   |  | <b>HT STAY INSULATOR</b>                               |  |
| <b>DRAWING NO. BPC-DDCS-2015-48</b>  |  | <b>REVISION</b>  |  |
|  |  | <b>2015</b>  |  |

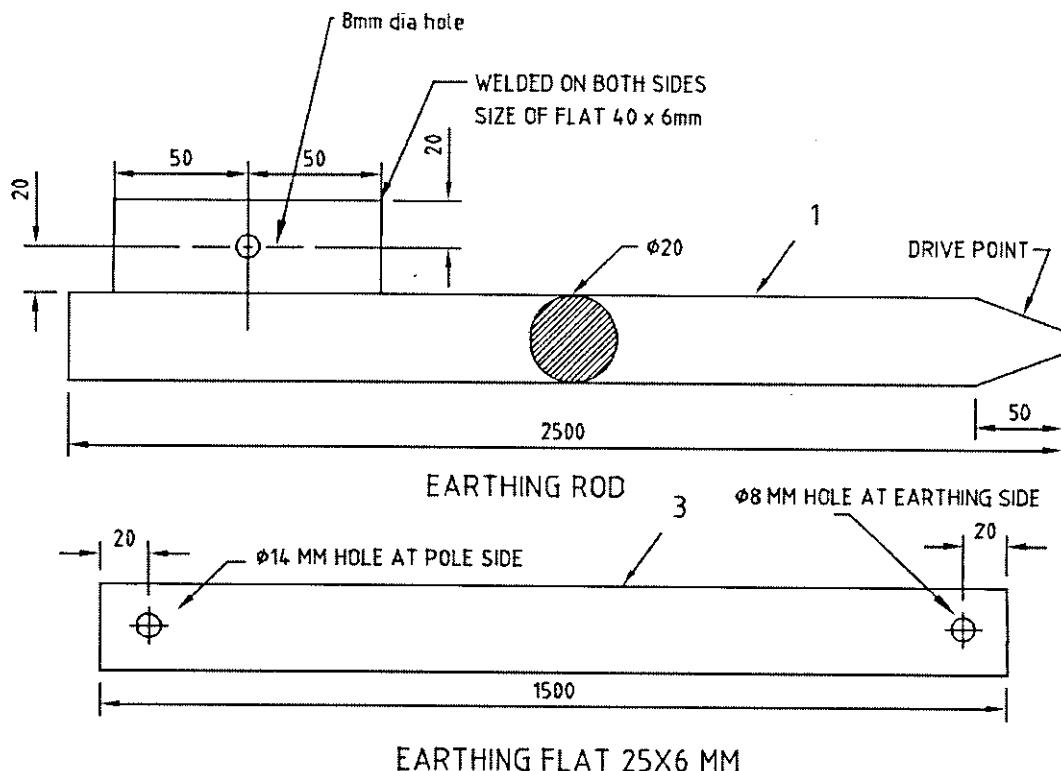

GRADE OF STEEL: BS 4360 GRADE 43A OR EQUIVALENT  
 GALVANISED TO: BS 729 OR EQUIVALENT  
 PACKING: EARTHING RODS, NUTS & BOLTS, FLATS  
 TO BE PACKED SEPARATELY

| 5  | WASHER SPRING        | 4  | HDG STEEL                    | M6               |              |  |  |          |  |  |                 |  |  |                    |  |  |  |  |  |
|--|----------------------|--|------------------------------|------------------|--------------|--|--|----------|--|--|-----------------|--|--|--------------------|--|--|--|--|--|
| 4  | NUT HEX              | 4  | HDG STEEL                    | M6               |              |  |  |          |  |  |                 |  |  |                    |  |  |  |  |  |
| 3  | EARTHING FLAT 25X6MM | 1  | HDG STEEL                    | 15Meter          |              |  |  |          |  |  |                 |  |  |                    |  |  |  |  |  |
| 2  | BOLT HEX             | 4  | HDG STEEL                    | M6 x 25 x FT     |              |  |  |          |  |  |                 |  |  |                    |  |  |  |  |  |
| 1  | EARTHING ROD         | 1  | HDG STEEL                    | M20 x 2500       |              |  |  |          |  |  |                 |  |  |                    |  |  |  |  |  |
| ITEM   | NAME OF ITEM         | QTY  | MATERIAL                     | SIZE             |              |  |  |          |  |  |                 |  |  |                    |  |  |  |  |  |
|  <b>BHUTAN POWER CORPORATION LIMITED</b>  |                      | <b>ENGINEERING DESIGN &amp; CONTRACTS DEPARTMENT</b> |                              |                  |              |  |  |          |  |  |                 |  |  |                    |  |  |  |  |  |
| <table border="1"> <tr> <th>TITLE</th> <th>NAME</th> <th>DATE</th> </tr> <tr> <td>DRAFTSPERSON</td> <td></td> <td></td> </tr> <tr> <td>DESIGNER</td> <td></td> <td></td> </tr> <tr> <td>PROJECT MANAGER</td> <td></td> <td></td> </tr> <tr> <td>HEAD OF DEPARTMENT</td> <td></td> <td></td> </tr> </table> |                      | TITLE  | NAME                         | DATE             | DRAFTSPERSON |  |  | DESIGNER |  |  | PROJECT MANAGER |  |  | HEAD OF DEPARTMENT |  |  | <b>DISTRUBUTION DESIGN &amp; CONSTRUCTION STANDARD</b> |  |  |
| TITLE  | NAME                 | DATE   |                              |                  |              |  |  |          |  |  |                 |  |  |                    |  |  |  |  |  |
| DRAFTSPERSON   |                      |  |                              |                  |              |  |  |          |  |  |                 |  |  |                    |  |  |  |  |  |
| DESIGNER   |                      |  |                              |                  |              |  |  |          |  |  |                 |  |  |                    |  |  |  |  |  |
| PROJECT MANAGER  |                      |  |                              |                  |              |  |  |          |  |  |                 |  |  |                    |  |  |  |  |  |
| HEAD OF DEPARTMENT   |                      |  |                              |                  |              |  |  |          |  |  |                 |  |  |                    |  |  |  |  |  |
|  |                      |  | <b>SPIKE EARTHING SET</b>    |                  |              |  |  |          |  |  |                 |  |  |                    |  |  |  |  |  |
|  |                      |  | DRAWING NO. BPC-DDCS-2015-49 | REVISION<br>2015 |              |  |  |          |  |  |                 |  |  |                    |  |  |  |  |  |



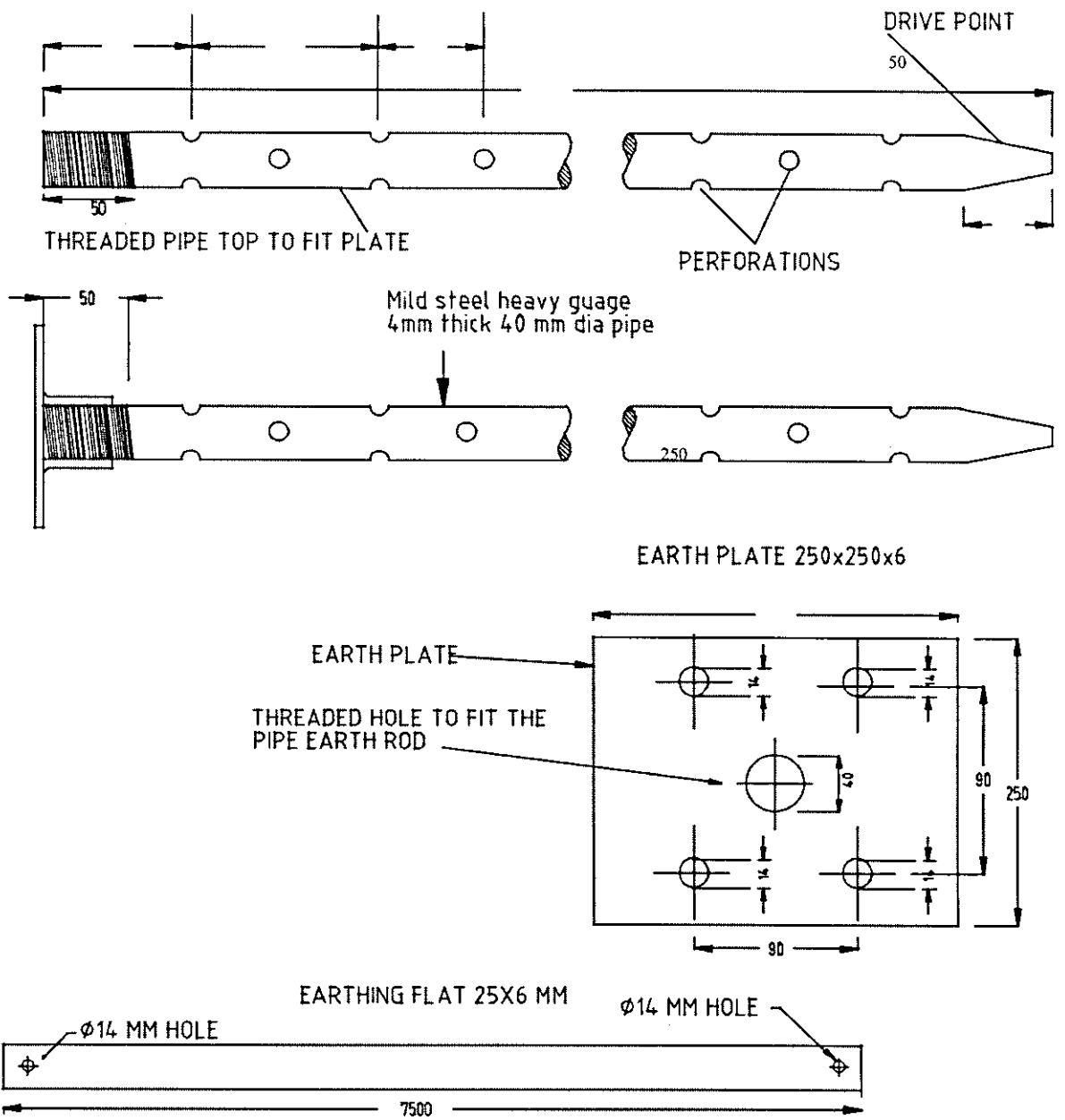

GRADE OF STEEL: BS 1387 OR EQUIVALENT  
 GALVANISED TO: BS 729 OR EQUIVALENT  
 PACKING: EARTING ROD,LUGS, BOLTS & NUTS  
 & GI FLAT , PLATE PACKED SEPARATELY

| NAME OF THE ITEM          | QTY | MATERIAL   |
|---------------------------|-----|------------|
| EARTHING FLAT (6.5 METER) | 11  | HD.G STEEL |
| FLANGED PLATE             | 1   | HD.G STEEL |
| SPRING WASHER             | 4   | HD.G STEEL |
| HEX NUT M06               | 4   | HD.G STEEL |
| HEX BOLT M06X25           | 4   | HD.G STEEL |
| EARTHING ROD              | 1   | HD.G STEEL |

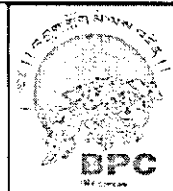

BHUTAN POWER CORPORATION LIMITED

ENGINEERING DESIGN & CONTRACTS DEPARTMENT

DISTRIBUTION DESIGN & CONSTRUCTION STANDARD

### ANCHOR ROD ASSEMBLY

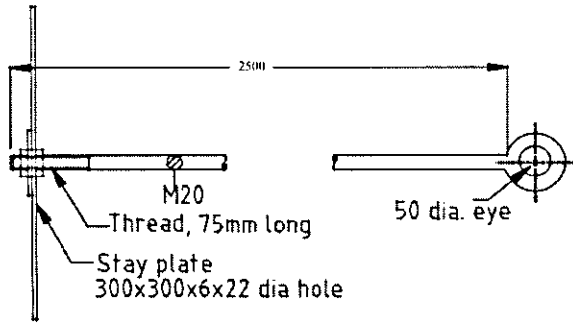

### TURN-BUCKLE ASSEMBLY

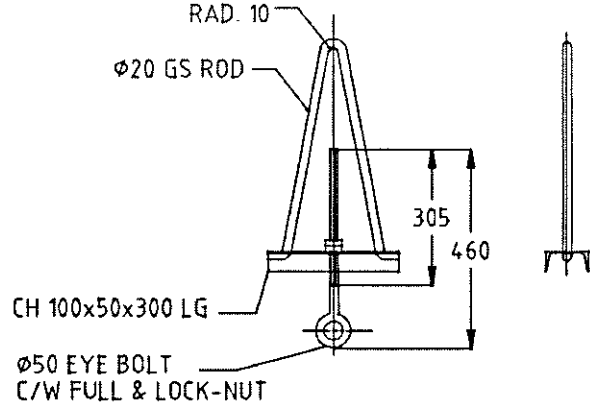

### STAY PLATE

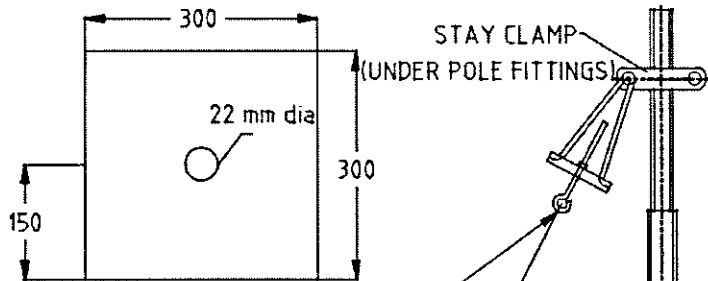

### EYE BOLT

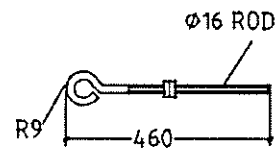

### V HANGER

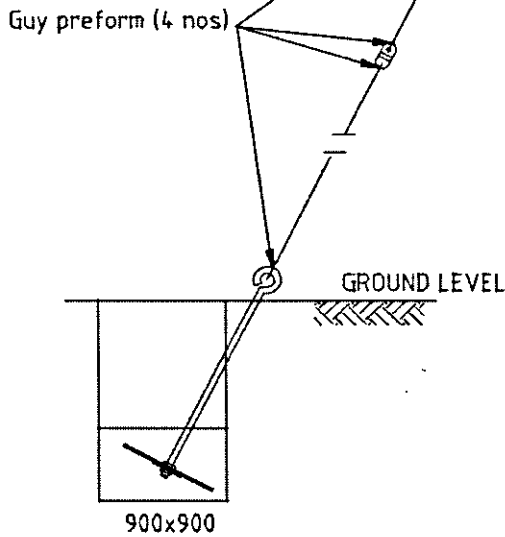
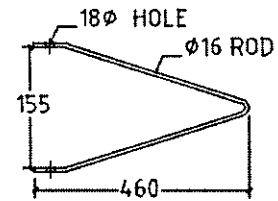

### STAY WIRE ASSEMBLY

### NOTES

- Stay rod and nuts assembled and packed together
- Anchor plates packed separately
- Material :- BS 4360 Grade 43A
- Galvanizing :- BS 729
- Threads :- ISO Metric
- Nut :- BS 4190 Grade 4.0

| NAME OF THE ITEM                   | QTY            | MATERIAL              |
|------------------------------------|----------------|-----------------------|
| V-HANGER ONLY FOR TELESCOPIC POLE  | 1              | H.D.G STEEL           |
| STAY WIRE (7/8 SWG) (IN METERS)    | 4M+POLE HEIGHT | H.D.G STEEL           |
| STAY CLAMP WITH NUTS AND BOLTS     | 1              | H.D.G STEEL           |
| STAY ROD (25 M) WITH THIMBLE       | 1              | H.D.G STEEL           |
| ANCHOR PLATE (300 X 300 X 6MM)     | 1              | H.D.G STEEL           |
| TURN BUCKLE ASSEMBLY WITH THIMBLE  | 1              | H.D.G STEEL           |
| GUY PREFORMED SUITABLE FOR 7/8 SWG | 4              | GALVANISED STEEL WIRE |
| STAY INSULATOR                     | 1              | PORCELAIN             |



BHUTAN POWER CORPORATION LIMITED

ENGINEERING DESIGN & CONTRACTS DEPARTMENT

DISTRIBUTION DESIGN & CONSTRUCTION STANDARD

STAY SET ASSEMBLY

REVISION 2015

DRAWING NO. BPC-DDCS-2015-51

| DESIGNATION      | NAME | DATE |
|------------------|------|------|
| DRAFTSMAN        |      |      |
| DESIGNER         |      |      |
| DESIGN CHECK     |      |      |
| PROJECT MANAGER  |      |      |
| PROJECT DIRECTOR |      |      |

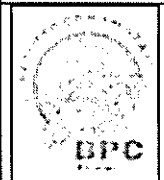
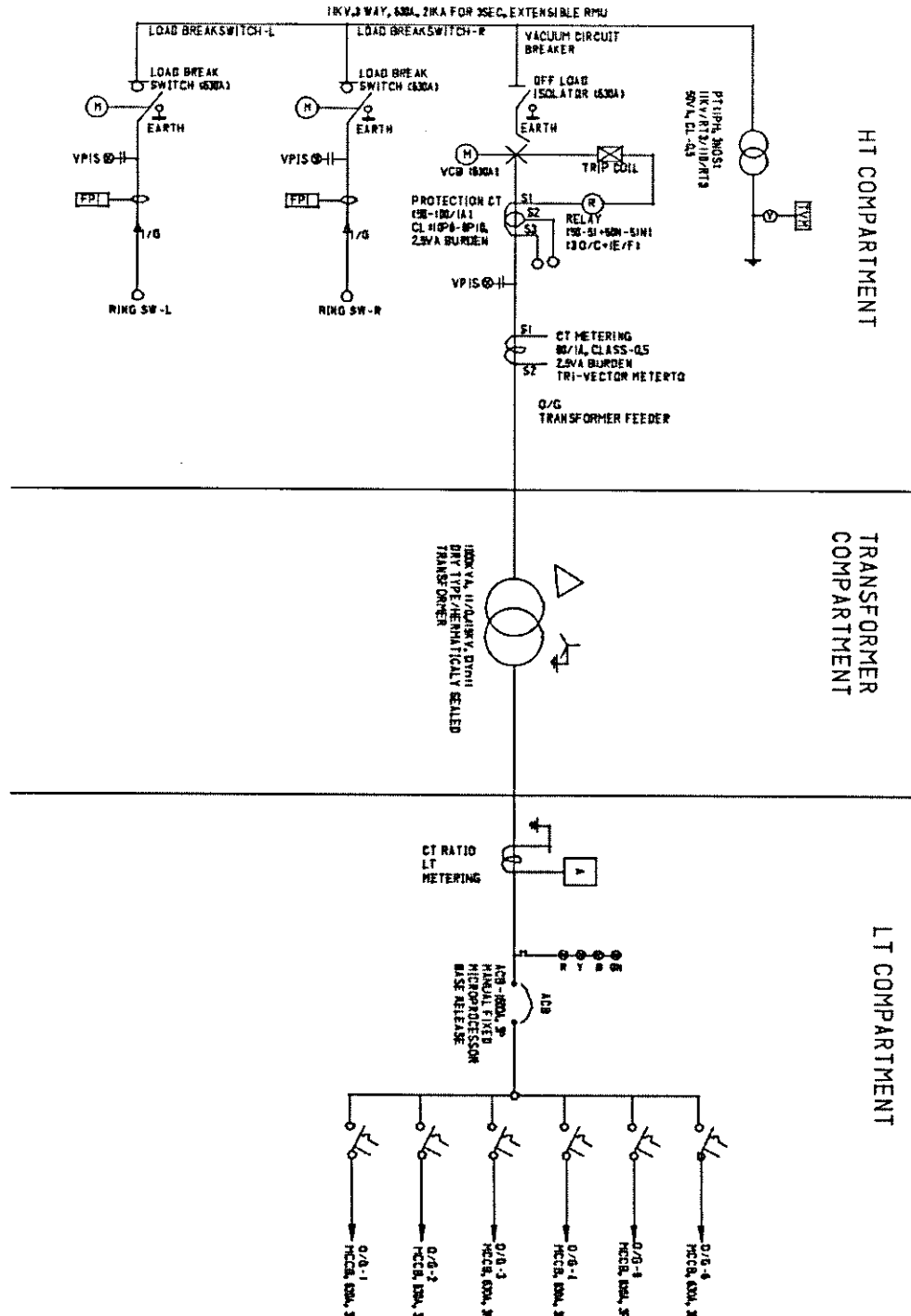

**BHUTAN POWER CORPORATION LIMITED**

**ENGINEERING DESIGN & CONTRACTS DEPARTMENT**

**TITLE : DISTRIBUTION DESIGN & CONSTRUCTION STANDARD**

**GENERAL ARRANGEMENT OF 4WAYS UNITIZED SUBSTATION**

| DESIGNATION      | NAME | DATE |
|------------------|------|------|
| DRAFTSMAN        |      |      |
| DESIGNER         |      |      |
| DESIGN CHECK     |      |      |
| PROJECT MANAGER  |      |      |
| PROJECT DIRECTOR |      |      |

DRAWING NO. BPC-DDCS-2015-52

REVISION  
2015

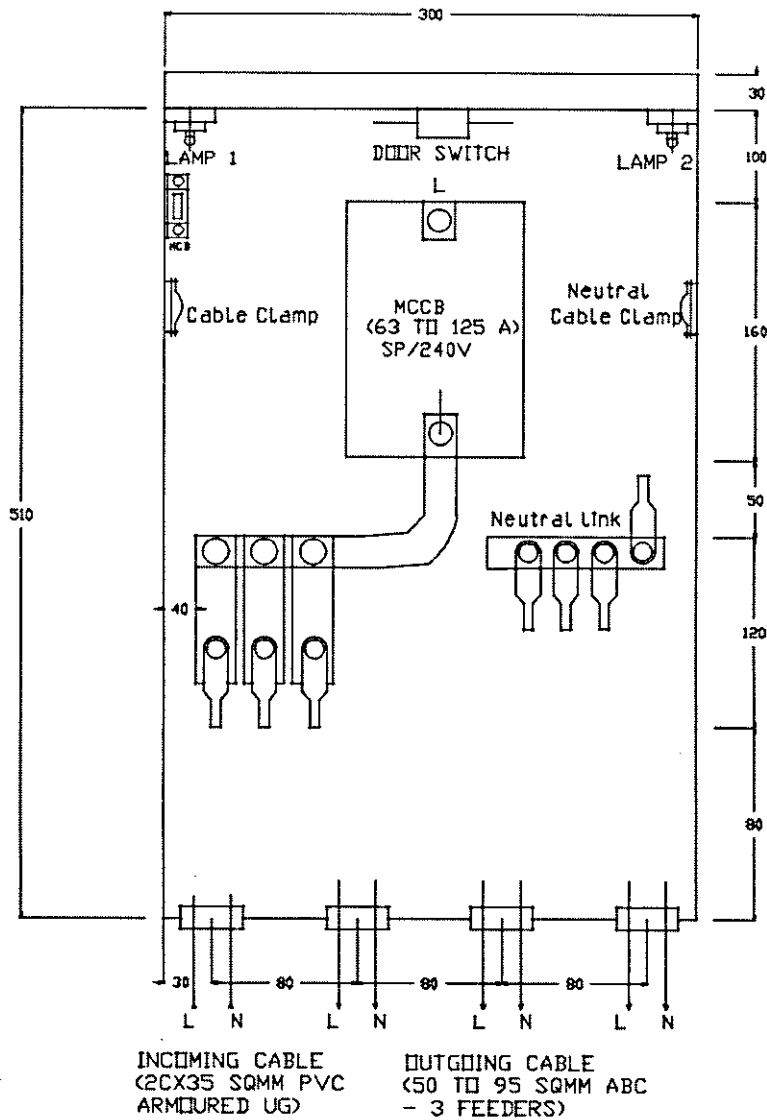

INTERNAL WIRING DIAGRAM OF DISTRIBUTION PILLAR

**NOTES**

INNER DEVICE :

MCCB: RATING UPTO 160 A, SPN,1 NO.

HRC FUSES: RATING UPTO 100 A - 3 NOS/2NOS DEPENDING ON NUMBER OF WAYS.

DIMENSIONS AS SHOWN ARE IN MM.

TO BE USED WITH 10 KVA, 16KVA AND 25KVA SINGLE PHASE TRANSFORMER RATINGS

CABLE LUG TO BE SUPPLIED FIXED WITH THE BOARD FOR APPROPRIATE CABLE SIZES.

|  |  |                  |
|--|--|------------------|
| <br><b>BHUTAN POWER CORPORATION LIMITED</b> | <b>ENGINEERING DESIGN &amp; CONTRACTS DEPARTMENT</b>   |                  |
|  | <b>TITLE : DISTRIBUTION DESIGN &amp; CONSTRUCTION STANDARD</b><br><br>SINGLE PHASE TRANSFORMER LT PANEL, 3 WAYS, INCOMER MCCB UPTO 160 A, OUTGOING HRC FUSE UPTO 100 A (INTERNAL VIEW) |                  |
| DESIGNATION  | NAME   | DATE             |
| DRAFTSMAN  |  |                  |
| DESIGNER   |  |                  |
| DESIGN CHECK   |  |                  |
| PROJECT MANAGER  |  |                  |
| PROJECT DIRECTOR   |  |                  |
| DRAWING NO. BPC-DDCS-2015-53/1   |  | REVISION<br>2015 |

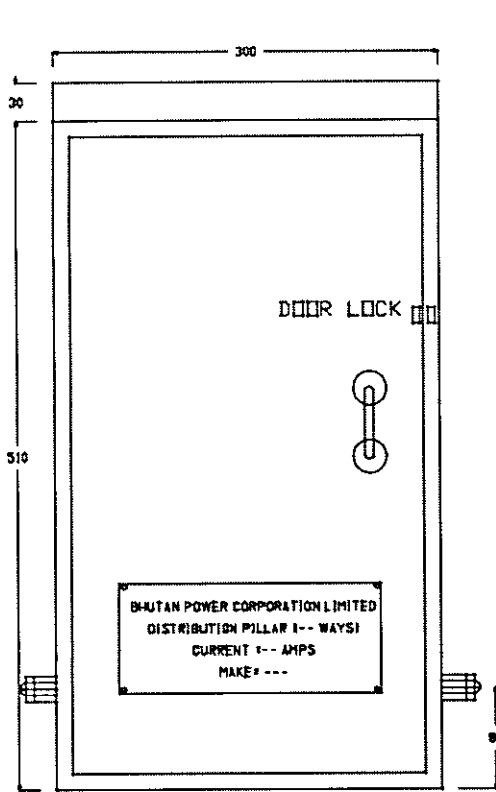

FRONT VIEW

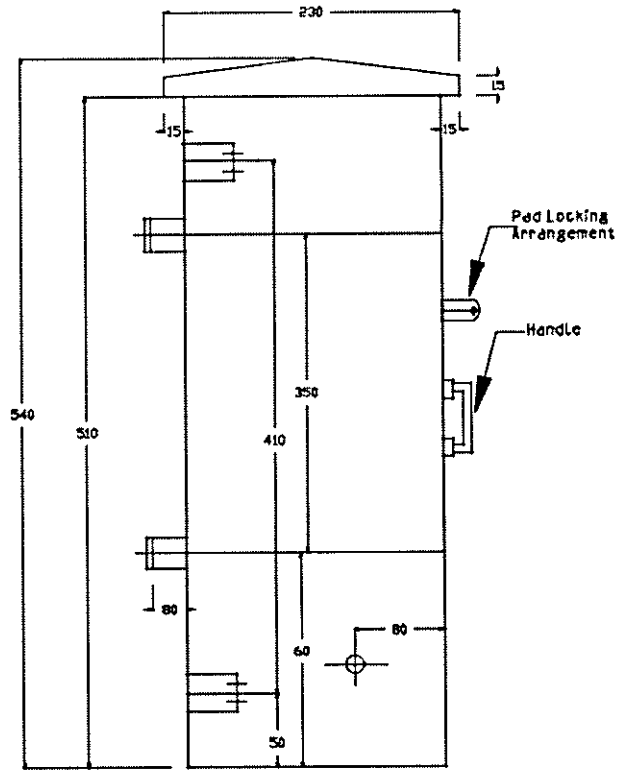

SIDE VIEW

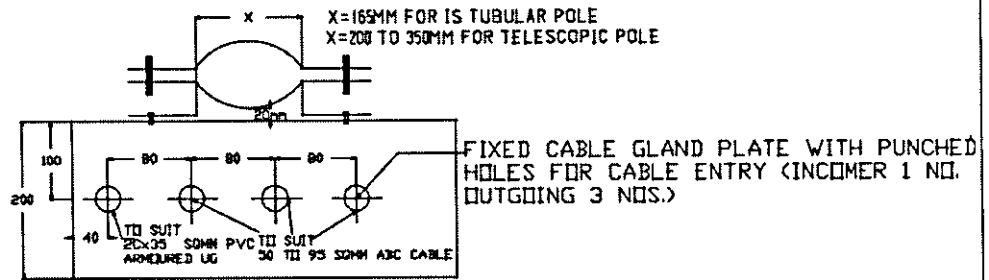

BOTTOM VIEW

NOTE:

| MCCB RATING | PHASE BUSBAR SIZE         | NEUTRAL BUSBAR SIZE       |
|-------------|---------------------------|---------------------------|
| 63A         | 12X6MM AL.ALLOY, GR-ESIE  | 12X6MM AL.ALLOY, GR-ESIE  |
| 100A        | 12X8MM AL.ALLOY, GR-ESIE  | 12X8MM AL.ALLOY, GR-ESIE  |
| 125A        | 18X8MM AL.ALLOY, GR-ESIE  | 18X8MM AL.ALLOY, GR-ESIE  |
| 160A        | 18X11MM AL.ALLOY, GR-ESIE | 18X11MM AL.ALLOY, GR-ESIE |

BAYONET LAMP (1 NO.) TO BE PROVIDED

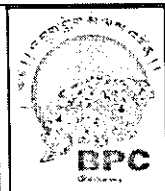

BHUTAN POWER CORPORATION LIMITED

ENGINEERING DESIGN & CONTRACTS DEPARTMENT

TITLE : DISTRIBUTION DESIGN & CONSTRUCTION STANDARD

SINGLE PHASE TRANSFORMER LT PANEL 3 WAYS, INCOMER MCCB-UP TO 160 A, OUTGOING HRC FUSE UP TO 100 A (EXTERNAL VIEW)

| DESIGNATION      | NAME | DATE |
|------------------|------|------|
| DRAFTSMAN        |      |      |
| DESIGNER         |      |      |
| DESIGN CHECK     |      |      |
| PROJECT MANAGER  |      |      |
| PROJECT DIRECTOR |      |      |

DRAWING NO. BPC-DDCS-2015-53/2

REVISION  
2015

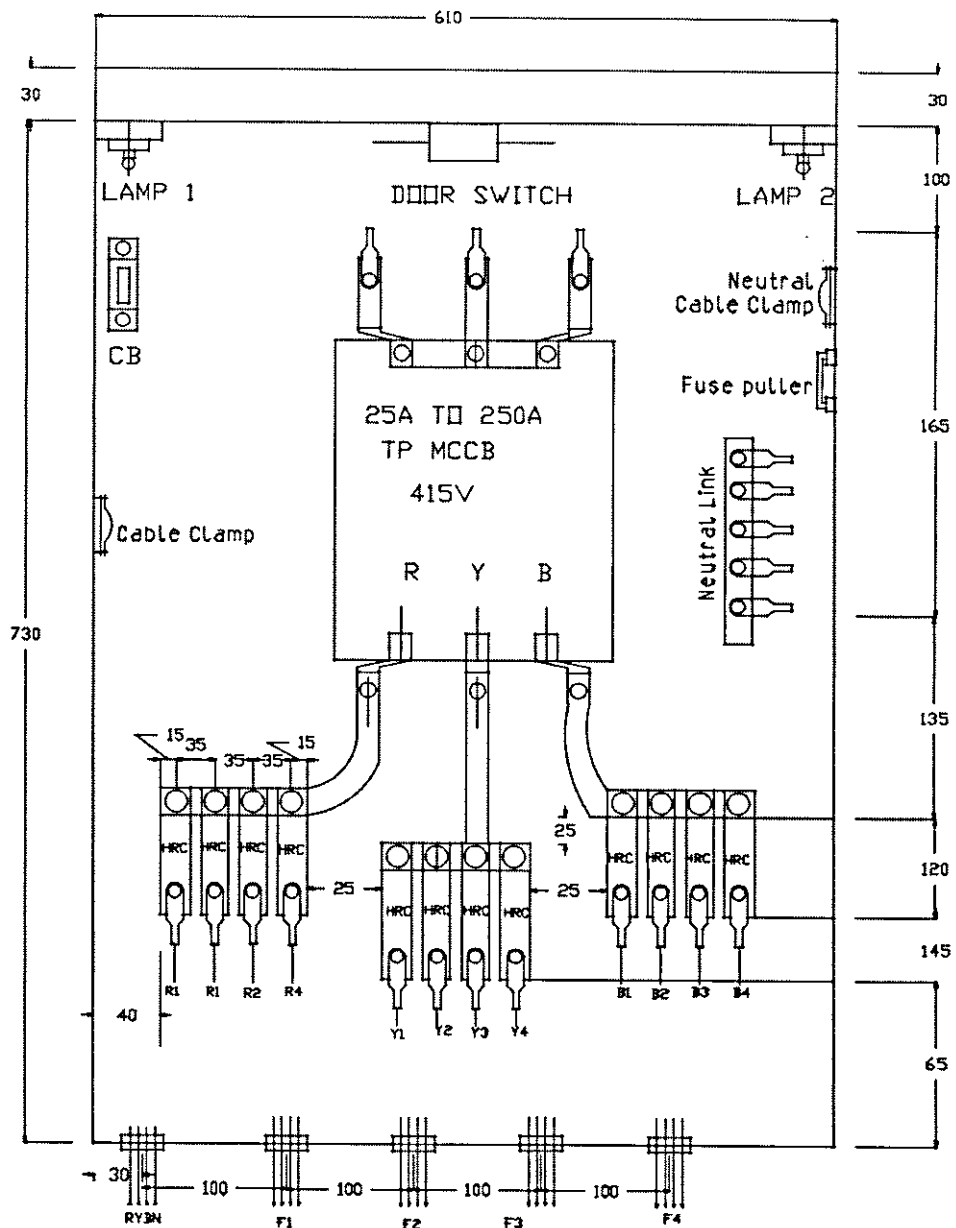

INCOMING CABLE  
(150 SQMM PVC  
ARMoured UG)

OUTGOING CABLE (50 TO 120SQMM  
ABC - 4 FEEDERS)

**NOTES**

INTERNAL WIRING DIAGRAM OF DISTRIBUTION PILLAR

INNER DEVICE:

MCCB UPTO 250A, 1NO, TPN-415V

HRC FUSES: UPTO 125A, 6 NOS/12NOS DEPENDING ON NUMBER OF WAYS

Provide one number of HRC fuse puller for every board.

TO BE USED WITH 16KVA, 25KVA, 63 kVA and 125 kVA 3PHASE TRANSFORMER RATINGS

CABLE LUG TO BE SUPPLIED FIXED WITH THE BOARD FOR APPROPRIATE CABLE SIZES.

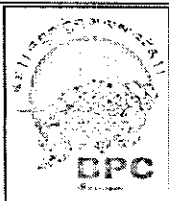

**BHUTAN POWER  
CORPORATION LIMITED**

**ENGINEERING DESIGN & CONTRACTS DEPARTMENT**

**TITLE : DISTRIBUTION DESIGN & CONSTRUCTION STANDARD**

THREE PHASE TRANSFORMER LT PANEL, 4 WAYS INCOMER,  
MCCB-UPTO 250A, OUTGOING HRC FUSE UPTO 125A (INTERNAL VIEW)

| DESIGNATION      | NAME | DATE |
|------------------|------|------|
| DRAFTSMAN        |      |      |
| DESIGNER         |      |      |
| DESIGN CHECK     |      |      |
| PROJECT MANAGER  |      |      |
| PROJECT DIRECTOR |      |      |

DRAWING NO. BPC-DDCS-2015-5A/1

REVISION  
2015

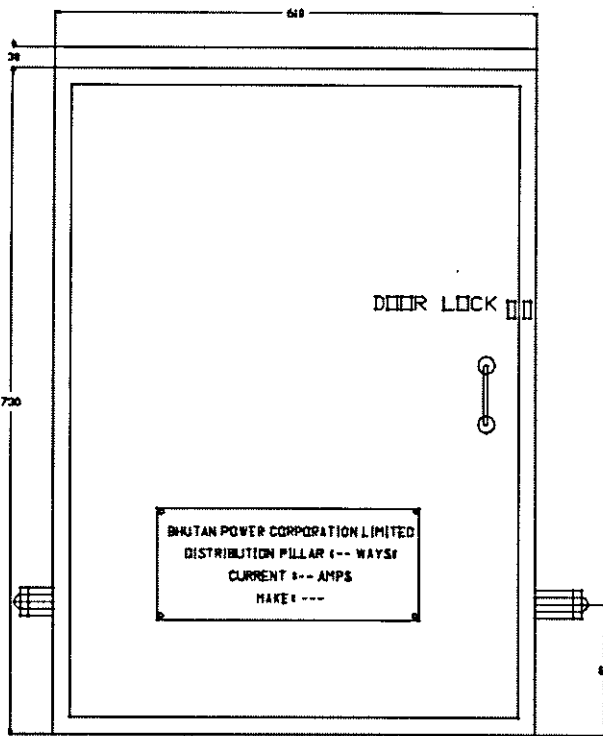

FRONT VIEW

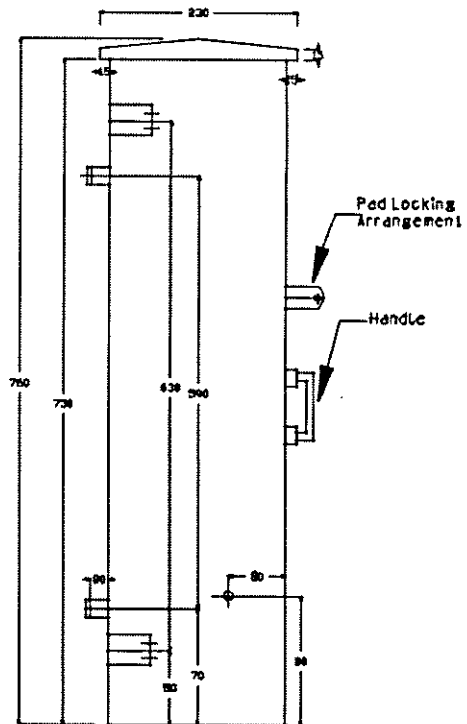

SIDE VIEW

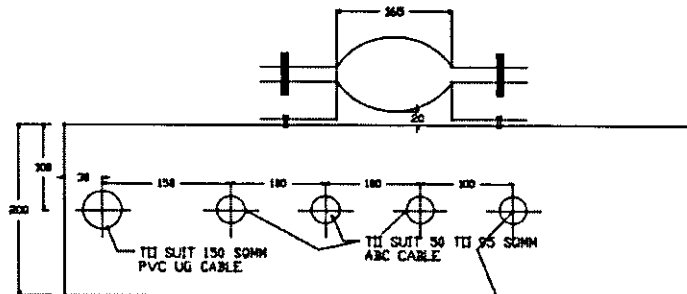

BOTTOM VIEW

FIXED CABLE GLAND PLATE WITH PUNCHED HOLES FOR CABLE ENTRY (OUTGOING 4 NOS) AND (INCOMING 1NO)

NOTE:

BUSBAR SIZE 25x10MM AL / 20x3MM CU  
 NEUTRAL BUSBAR 25x5MM AL / 20x3MM CU  
 BAYONET LAMP (IND) TO BE PROVIDED

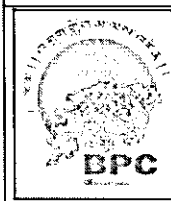

BHUTAN POWER CORPORATION LIMITED

ENGINEERING DESIGN & CONTRACTS DEPARTMENT

TITLE : DISTRIBUTION DESIGN & CONSTRUCTION STANDARD

THREE PHASE TRANSFORMER LT PANEL, 4 WAYS, INCOMER MCCB-UP TO 250A, OUTGOING HRC FUSE UP TO 125A (EXTERNAL VIEW)

| DESIGNATION      | NAME | DATE |
|------------------|------|------|
| DRAFTSMAN        |      |      |
| DESIGNER         |      |      |
| DESIGN CHECK     |      |      |
| PROJECT MANAGER  |      |      |
| PROJECT DIRECTOR |      |      |

DRAWING NO. BPC-00CS-2015-54/2

REVISION  
2015

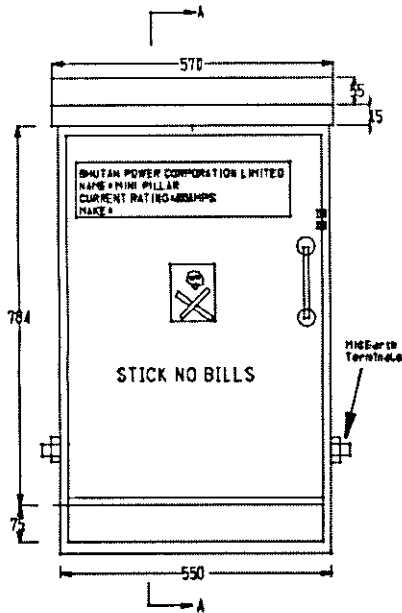

FRONT ELEVATION

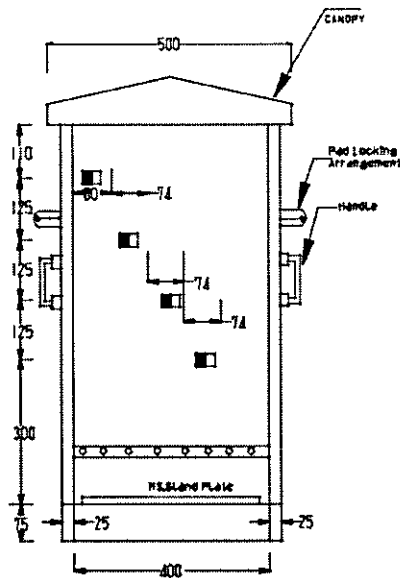

SIDE ELEVATION: (A-A)

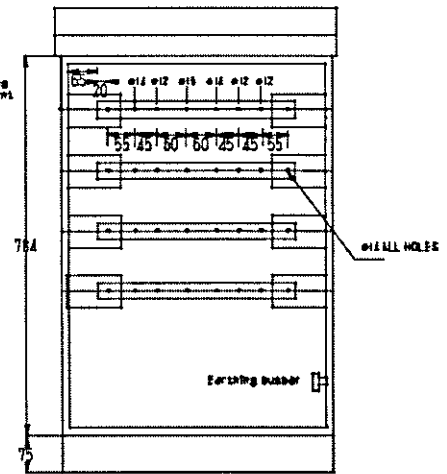

FRONT ELEVATION WITHOUT DOOR

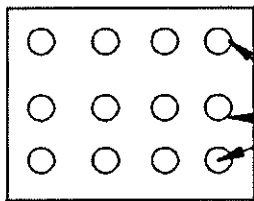

GLAND PLATE DETAILS

PUNCH HOLES FOR CABLE ENTRY VARIOUS SIZE OF CABLES FROM 16SQMM TO 300SQMM

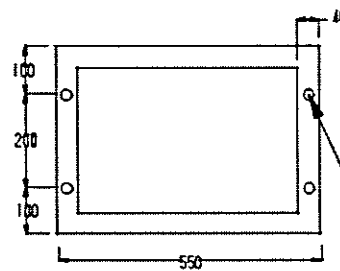

FOUNDATION PLAN

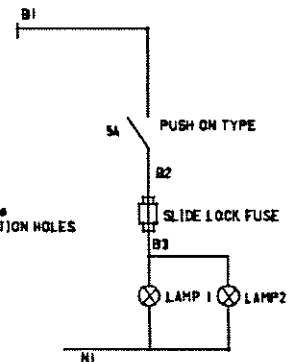

PHASE BUSBAR - 1X6X50MM AL. ALLOY  
 NEUTRAL - 1X6X50MM AL ALLOY.  
 MATERIAL - THE FEEDER PILLAR (INCLUDING BASE CHANNEL SHALL BE FABRICATED OUT OF 2.5MM MS SHEET  
 PAINT - SIEMENS GREY (OUTSIDE) & WHITE (INSIDE)  
 EARTH BUSBAR - 1X6X19MM AL. ALLOY.

NOTES  
 1. DIMENSIONS AS SHOWN ARE IN MM.  
 2. DRAWING NOT TO SCALE.

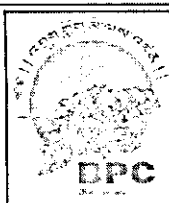

BHUTAN POWER CORPORATION LIMITED

ENGINEERING DESIGN & CONTRACTS DEPARTMENT

TITLE : DISTRIBUTION DESIGN & CONSTRUCTION STANDARD

MINI FEEDER PILLAR 400AMPS

| DESIGNATION      | NAME | DATE |
|------------------|------|------|
| DRAFTSMAN        |      |      |
| DESIGNER         |      |      |
| DESIGN CHECK     |      |      |
| PROJECT MANAGER  |      |      |
| PROJECT DIRECTOR |      |      |

DRAWING NO. BPC-DDCS-2015-55

REVISION

2015



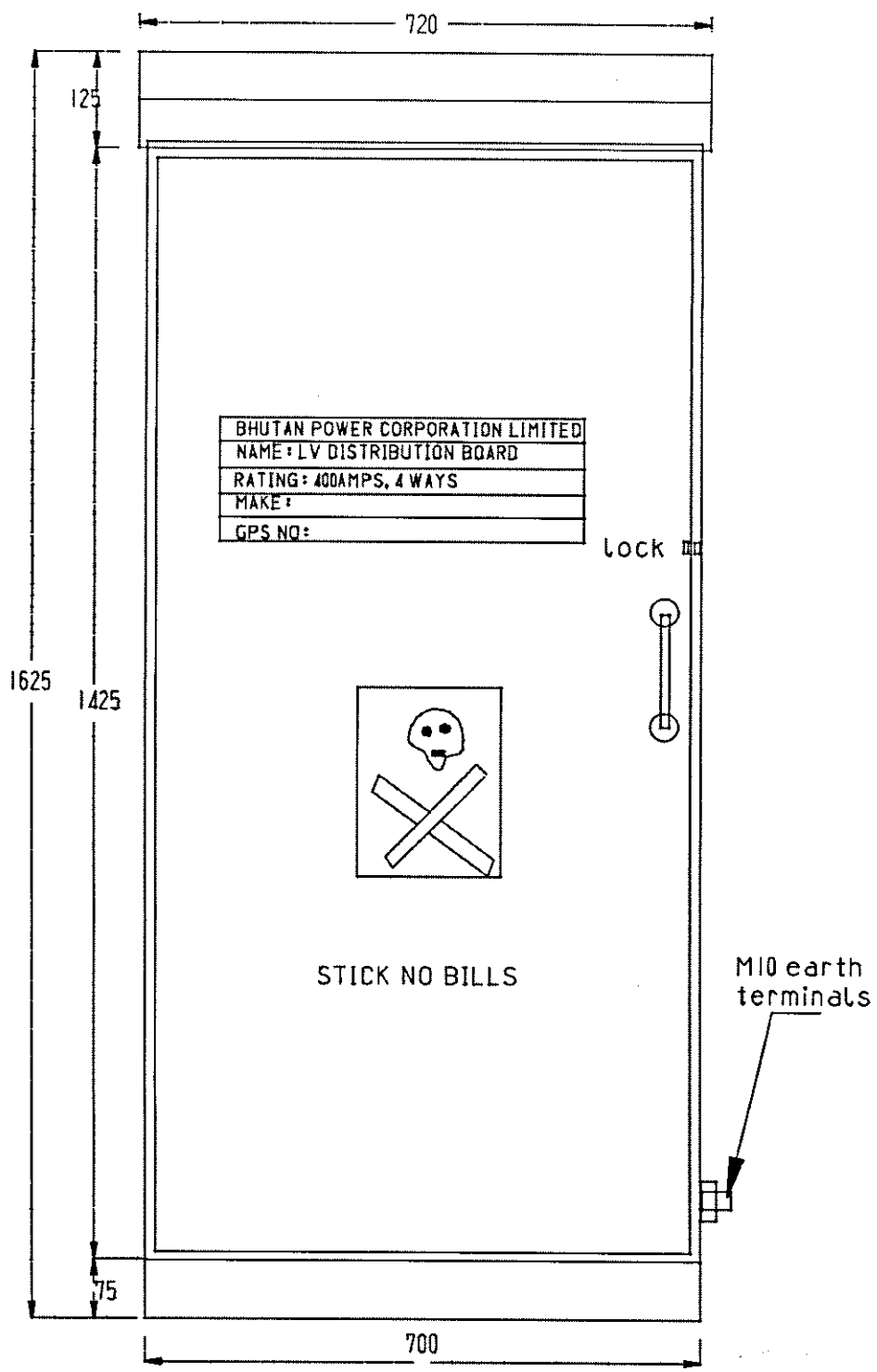

**NOTES**

- 1. DIMENSIONS AS SHOWN ARE INMM
- 2. DRAWING NOT TO SCALE.

|   |   |      |   |  |
|---|---|------|---|--|
|  | <p align="center"><b>BHUTAN POWER CORPORATION LIMITED</b></p> |      | <p align="center">ENGINEERING DESIGN &amp; CONTRACTS DEPARTMENT</p>           |  |
|   |   |      | <p align="center">TITLE : DISTRIBUTION DESIGN &amp; CONSTRUCTION STANDARD</p> |  |
| <p align="center">4WAYS TRANSFORMER DISTRIBUTION PILLAR<br/>(FRONT ELEVATION)</p>   |   |      |   |  |
| DESIGNATION   | NAME  | DATE | DRAWING NO. BPC-DDCS-2015-55/1  |  |
| DRAFTSMAN   |   |      | REVISION  |  |
| DESIGNER  |   |      | 2015  |  |
| DESIGN CHECK  |   |      |   |  |
| PROJECT MANAGER   |   |      |   |  |
| PROJECT DIRECTOR  |   |      |   |  |

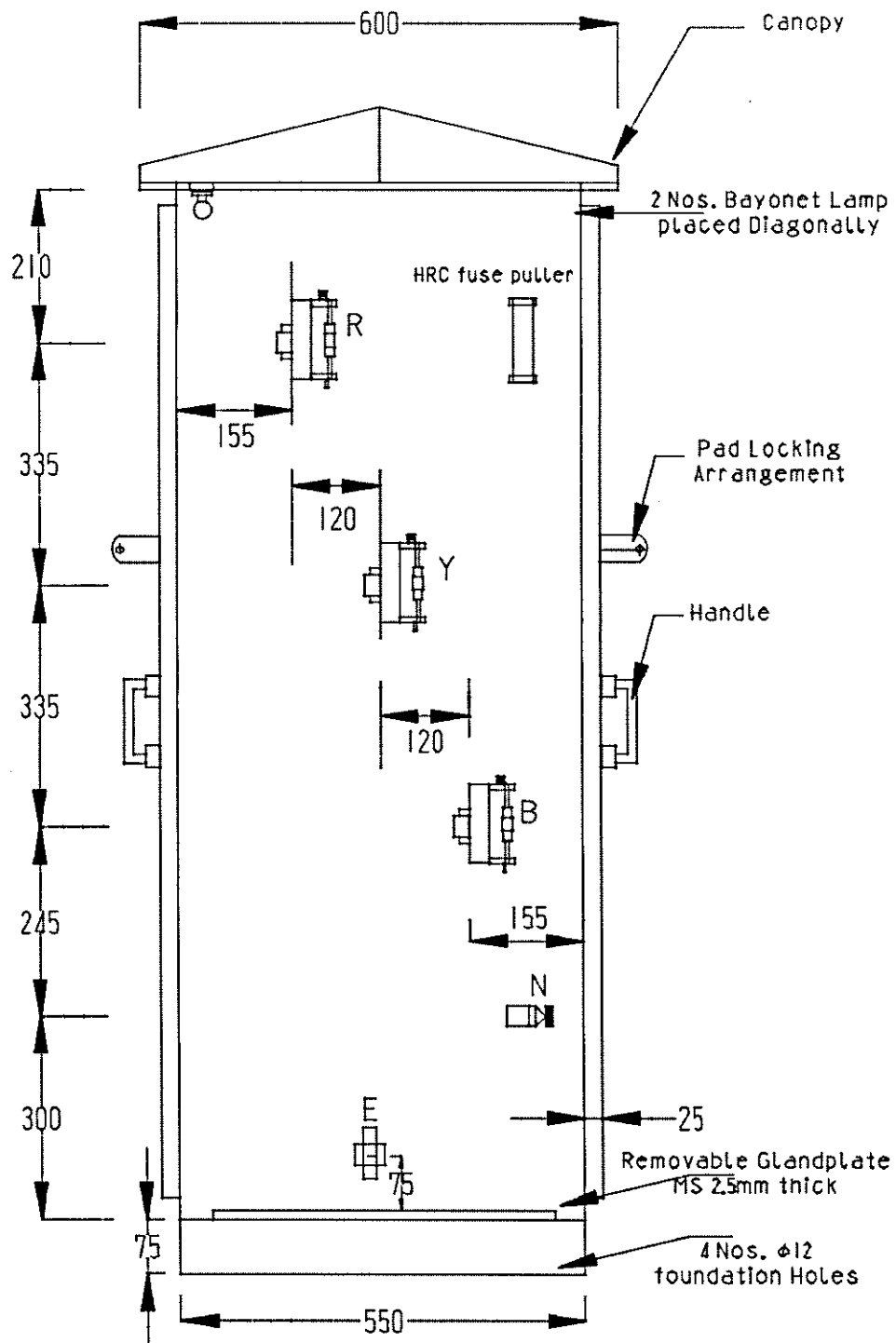

**NOTES**

1. DIMENSIONS AS SHOWN ARE IN MM. ALL PARTS SHALL BE TWO SIDED DOORS
2. DRAWING NOT TO SCALE.

|                  |   |      |   |  |
|------------------|---|------|---|--|
|                  | <b>BHUTAN POWER CORPORATION LIMITED</b> |      | <b>ENGINEERING DESIGN &amp; CONTRACTS DEPARTMENT</b>  |  |
|                  |   |      | <b>TITLE : DISTRIBUTION DESIGN &amp; CONSTRUCTION STANDARD</b><br><b>4WAYS TRANSFORMER DISTRIBUTION PILLAR</b><br><b>(SIDE ELEVATION)</b> |  |
| DESIGNATION      | NAME                                    | DATE | REVISION<br>2015<br>Distribution design and construction standards  |  |
| DRAFTSMAN        |   |      |   |  |
| DESIGNER         |   |      |   |  |
| DESIGN CHECK     |   |      |   |  |
| PROJECT MANAGER  |   |      |   |  |
| PROJECT DIRECTOR |   |      | DRAWING NO. BPC-DDCS-2015-56/2  |  |

Paino Switch & Rewireable Fuse for Lamp

HRC fuse puller

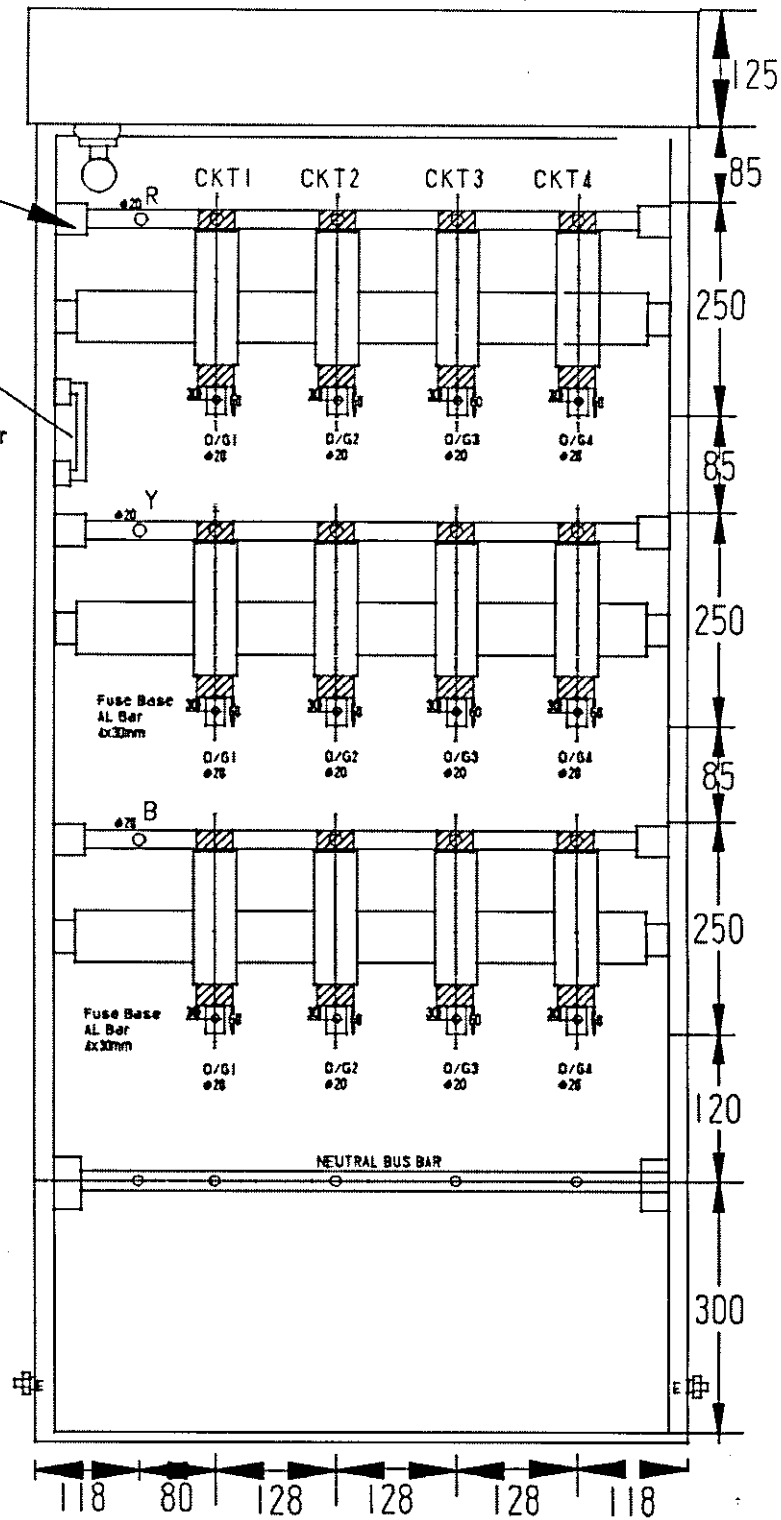

NOTES

1. DIMENSIONS AS SHOWN ARE IN MM.
2. PROVIDE ONE NO. OF FUSE PULLER FOR EVERY DISTRIBUTION BOARD.



BHUTAN POWER CORPORATION LIMITED

ENGINEERING DESIGN & CONTRACTS DEPARTMENT

TITLE : DISTRIBUTION DESIGN & CONSTRUCTION STANDARD

4WAYS TRANSFORMER DISTRIBUTION PILLAR  
(FRONT ELEVATION WITHOUT DOOR)

| DESIGNATION      | NAME | DATE |
|------------------|------|------|
| DRAFTSMAN        |      |      |
| DESIGNER         |      |      |
| DESIGN CHECK     |      |      |
| PROJECT MANAGER  |      |      |
| PROJECT DIRECTOR |      |      |

DRAWING NO. BPC-DOCS-2015-56/3

REVISION

2015

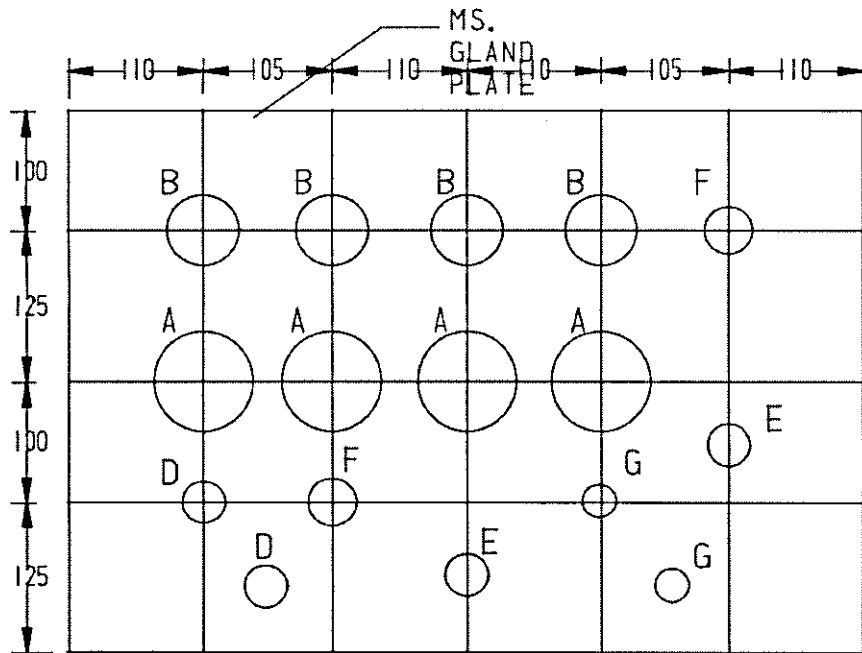

| MS. GLAND PLATE             | HOLE SIZE |
|-----------------------------|-----------|
| A - 4CX 400SQ.MM - KNOCKOUT | 3-1/8"    |
| B - 4CX 300SQ.MM - KNOCKOUT | 2-3/4"    |
| C - 2CX 16SQ.MM             | 1"        |
| D - 4CX 50SQ.MM - KNOCKOUT  | 1-1/2"    |
| E - 4CX 150SQ.MM - KNOCKOUT | 2"        |
| F - 4CX 240SQ.MM - KNOCKOUT | 2-1/2"    |
| G - 4CX 95SQ.MM - KNOCKOUT  | 1-3/4"    |
| h - 2CX 6SQ.MM              | 3/4"      |
| I - 2CX 10SQ.MM             | 1"        |

**NOTES**

1. DIMENSIONS AS SHOWN ARE IN MM.
2. DRAWING NOT TO SCALE.
3. CORRECT CABLE GLAND SIZE TO BE USED ACCORDINGLY WITH CABLE SIZE

|   |   |  |                         |
|---|---|--|-------------------------|
|  | <b>BHUTAN POWER CORPORATION LIMITED</b> | <b>ENGINEERING DESIGN &amp; CONTRACTS DEPARTMENT</b>               |                         |
|   |   | <b>TITLE : DISTRIBUTION DESIGN &amp; CONSTRUCTION STANDARD</b>     |                         |
| <b>DESIGNATION</b>  |   | <b>4WAYS TRANSFORMER DISTRIBUTION PILLAR (GLAND PLATE DETAILS)</b> |                         |
| <b>DRAFTSMAN</b>  | <b>NAME</b>                             | <b>DATE</b>  | <b>REVISION</b><br>2015 |
| <b>DESIGNER</b>   |   |  |                         |
| <b>DESIGN CHECK</b>   |   |  |                         |
| <b>PROJECT MANAGER</b>  |   |  |                         |
| <b>PROJECT DIRECTOR</b>   |   |  |                         |
| <b>DRAWING NO. BPC-DDCS-2015-56/4</b>   |   |  |                         |

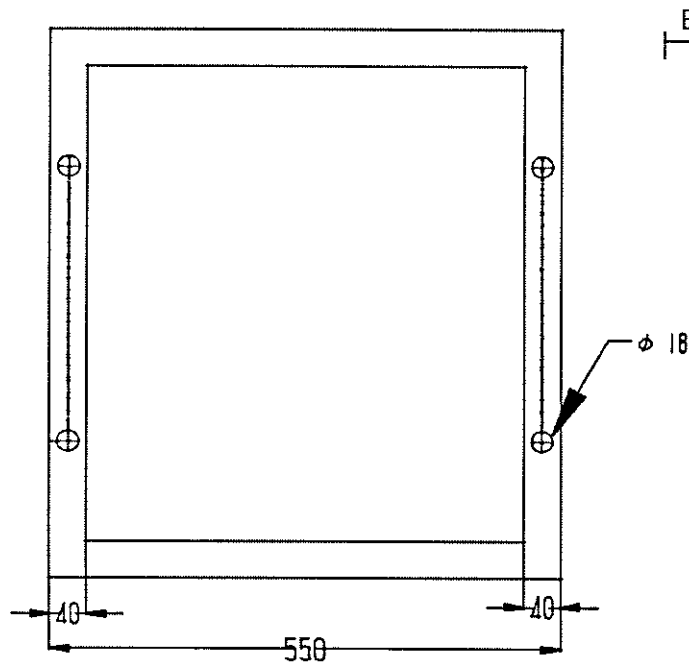

FOUNDATION PLAN

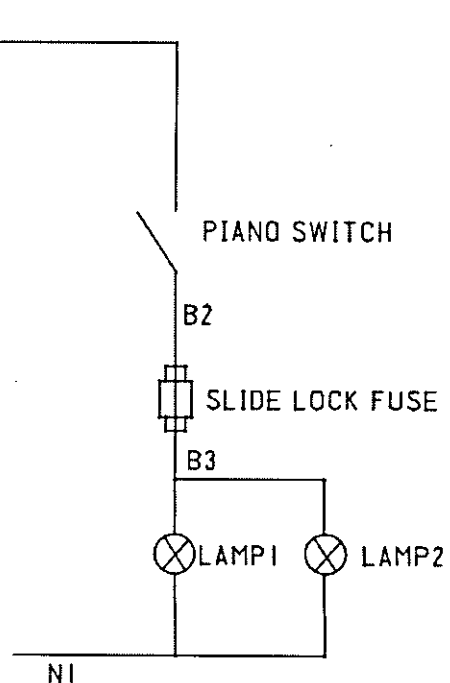

NOTES:

- PHASE - 50X6MM AL - 3NOS.
- NEUTRAL - 50X6MM AL - 1 NO. MATERIAL - THE FEEDER PILLAR (INCLUDING BASE CHANNEL) SHALL BE FABRICATED OUT OF 2.5MM MS SHEET.
- PAINT - SEIMENS GREY.
- EARTH - 1X6X19MM, AL ALLOY.

|   |   |  |  |  |
|---|---|--|--|--|
|  | <b>BHUTAN POWER CORPORATION LIMITED</b> |  | <b>ENGINEERING DESIGN &amp; CONTRACTS DEPARTMENT</b>                               |  |
|   |   |  | <b>TITLE : DISTRIBUTION DESIGN &amp; CONSTRUCTION STANDARD</b>                     |  |
| <b>DESIGNATION</b>  |   |  | <b>4WAYS TRANSFORMER DISTRIBUTION PILLAR (FOUNDATION DETAILS AND LIGHTING CKT)</b> |  |
| <b>NAME</b>   |   |  |  |  |
| <b>DATE</b>   |   |  |  |  |
| <b>DRAFTSMAN</b>  |   |  |  |  |
| <b>DESIGNER</b>   |   |  |  |  |
| <b>DESIGN CHECK</b>   |   |  |  |  |
| <b>PROJECT MANAGER</b>  |   |  | <b>DRAWING NO. BPC - DDCS - 2015 - 56/5</b>  |  |
| <b>PROJECT DIRECTOR</b>   |   |  | <b>REVISION</b><br>2015  |  |

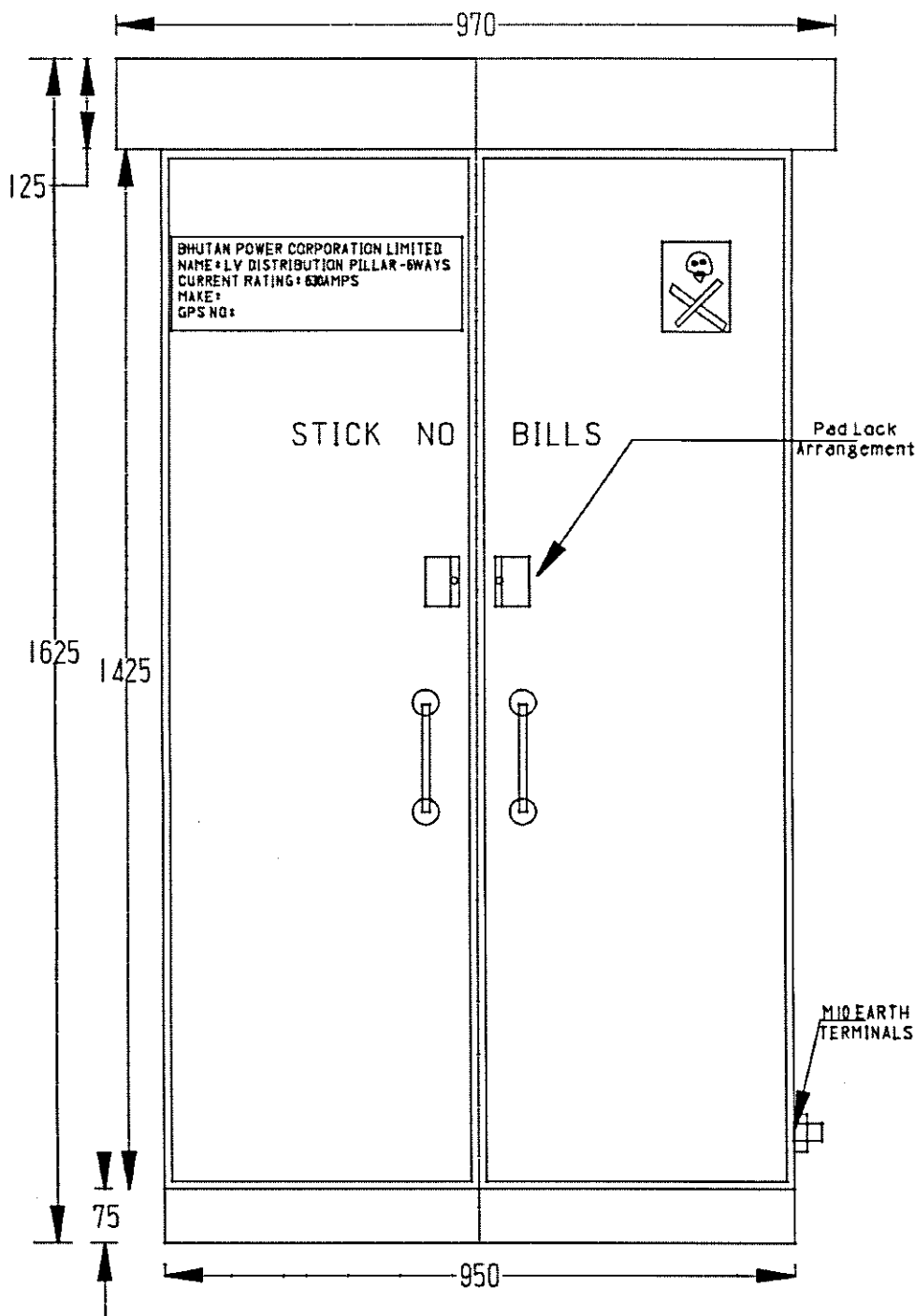

**NOTES**

- 1. DIMENSIONS AS SHOWN ARE INMM.
- 2. DRAWING NOT TO SCALE.

|  |   |                  |
|--|---|------------------|
|  <p><b>BHUTAN POWER CORPORATION LIMITED</b></p> | ENGINEERING DESIGN & CONTRACTS DEPARTMENT   |                  |
|  | <p>TITLE : DISTRIBUTION DESIGN &amp; CONSTRUCTION STANDARD</p> <p>6WAYS TRANSFORMER DISTRIBUTION PILLAR<br/>(FRONT ELEVATION)</p> |                  |
| DESIGNATION  | NAME  | DATE             |
| DRAFTSMAN  |   |                  |
| DESIGNER   |   |                  |
| DESIGN CHECK   |   |                  |
| PROJECT MANAGER  |   |                  |
| PROJECT DIRECTOR   |   |                  |
| DRAWING NO. BPC-DCS-2015-57/1  |   | REVISION<br>2015 |

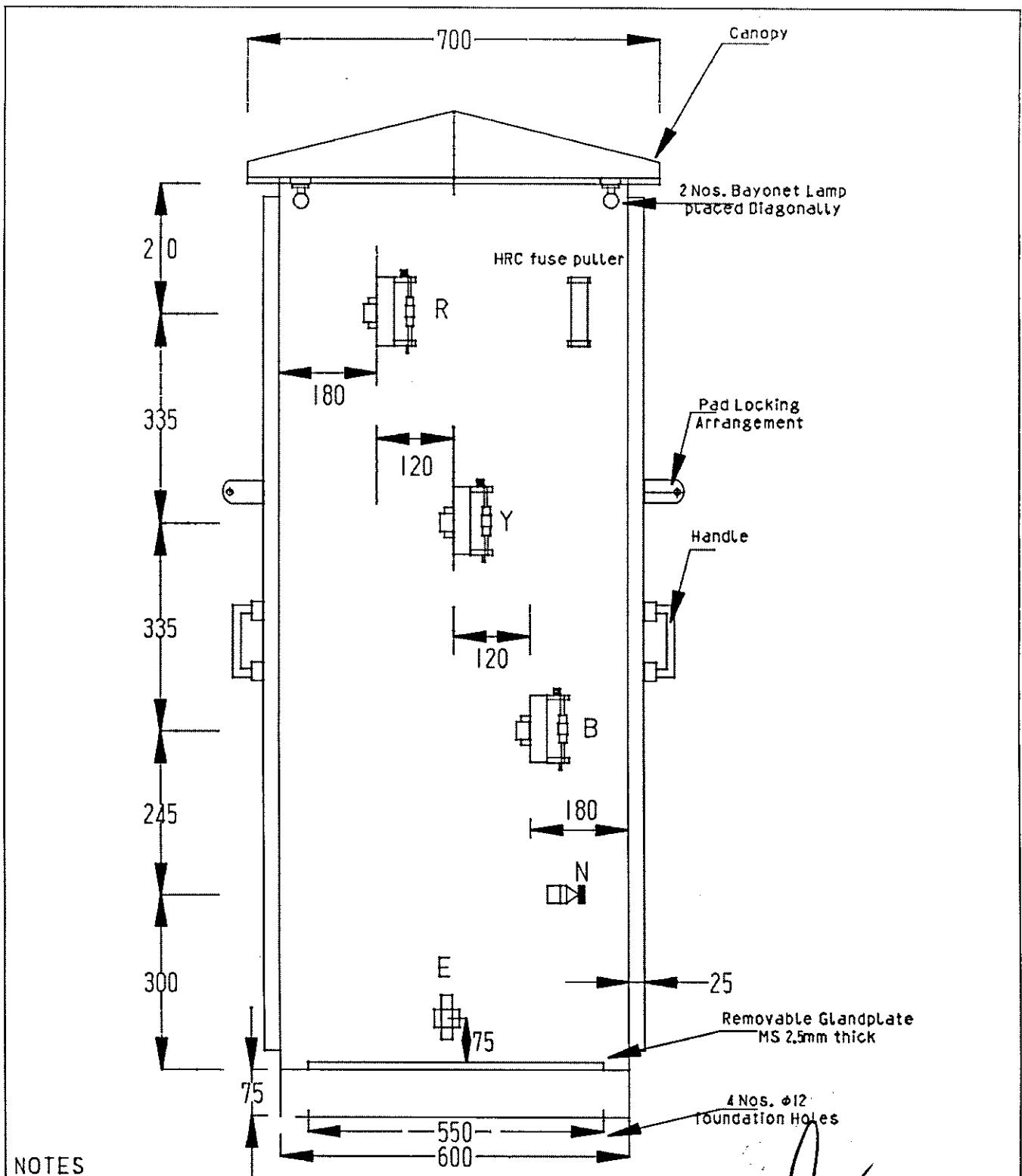

NOTES

2. DRAWING NOT TO SCALE.

|  |   |   |  |  |
|--|---|---|--|--|
|  | <b>BHUTAN POWER CORPORATION LIMITED</b> |   | <b>ENGINEERING DESIGN &amp; CONTRACTS DEPARTMENT</b>           |  |
|  |   |   | <b>TITLE : DISTRIBUTION DESIGN &amp; CONSTRUCTION STANDARD</b> |  |
|  |   | <b>6WAYS TRANSFORMER DISTRIBUTION PILLAR (SIDE ELEVATION)</b> |  |  |
| DESIGNATION  | NAME                                    | DATE  | REVISION<br><br>DRAWING NO. BPC-DDCS-2015-57/2<br>200          |  |
| DRAFTSMAN  |   |   |  |  |
| DESIGNER   |   |   |  |  |
| DESIGN CHECK                                       |   |   |  |  |
| PROJECT MANAGER                                    |   |   |  |  |
| PROJECT DIRECTOR design and construction standards |   |   | REVISION<br><br>2015   |  |

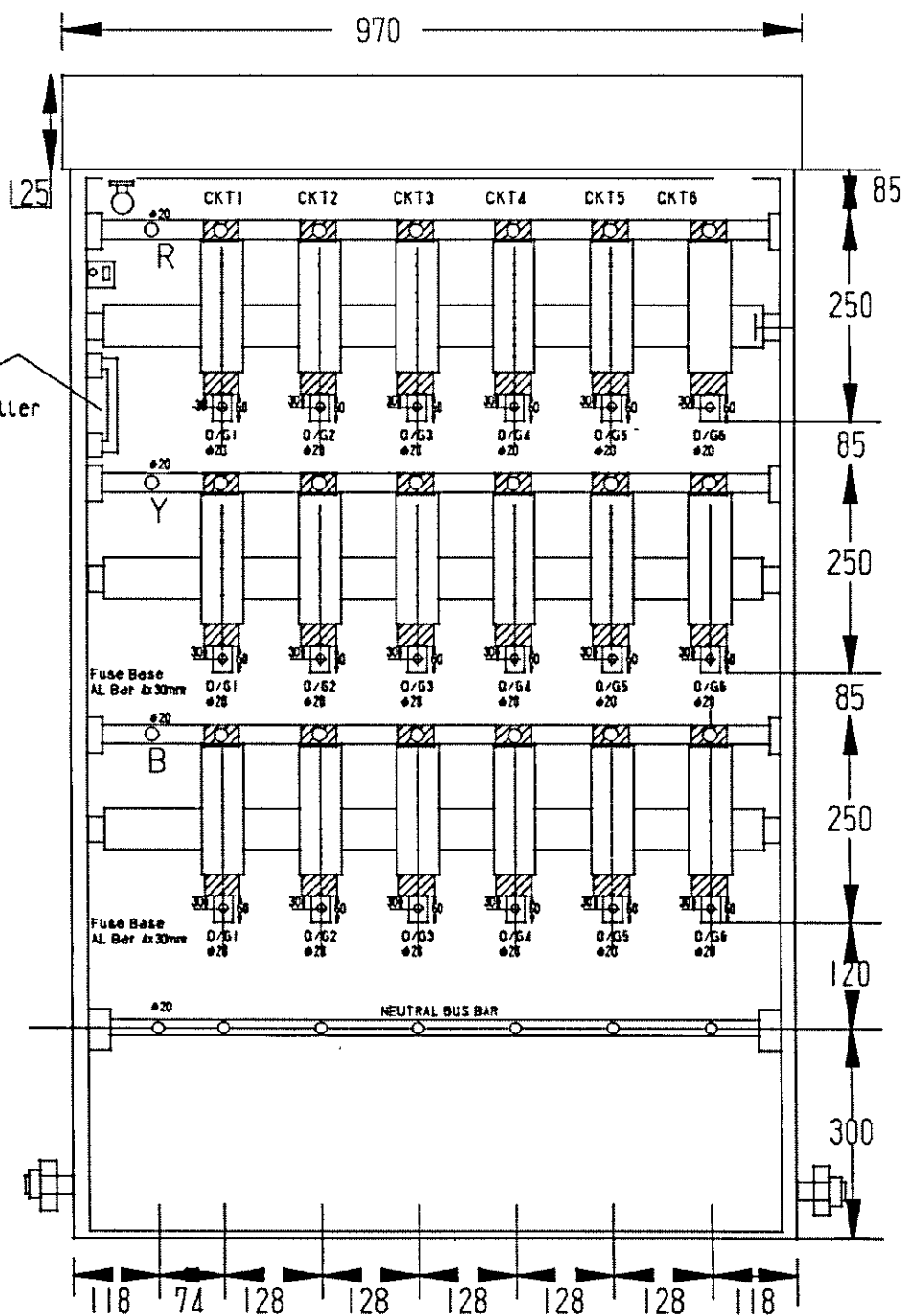

**NOTES**

1. DIMENSIONS AS SHOWN ARE IN MM.
2. PROVIDE ONE NO. FUSE FULLER FOR EVERY DISTRIBUTION BOARD
3. HRC FUSE RATING :  
 400AMPS FOR 315KVA TRANSFORMER  
 500AMPS FOR 400-500KVA TRANSFORMER

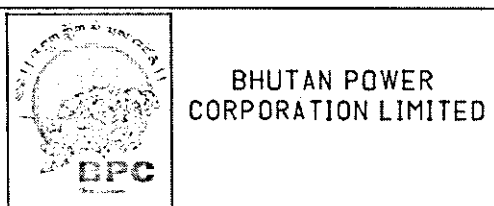

**BHUTAN POWER CORPORATION LIMITED**

**ENGINEERING DESIGN & CONTRACTS DEPARTMENT**

**TITLE : DISTRIBUTION DESIGN & CONSTRUCTION STANDARD**

**6WAYS TRANSFORMER DISTRIBUTION PILLAR  
(FRONT ELEVATION WITHOUT DOOR)**

| DESIGNATION      | NAME | DATE |
|------------------|------|------|
| DRAFTSMAN        |      |      |
| DESIGNER         |      |      |
| DESIGN CHECK     |      |      |
| PROJECT MANAGER  |      |      |
| PROJECT DIRECTOR |      |      |

DRAWING NO. BPC-DDCS-2015-57/3

REVISION  
2015



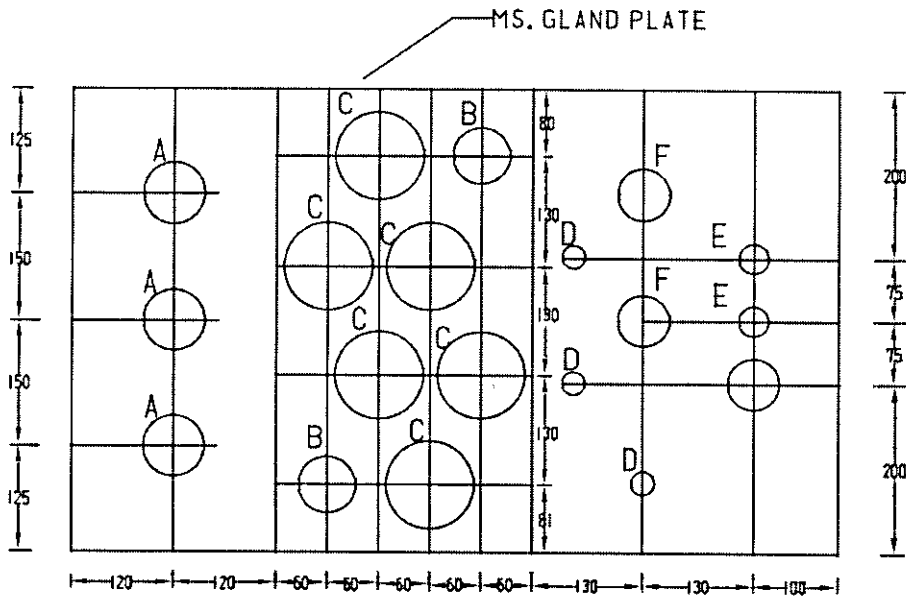

MS. GLAND PLATE

HOLE SIZE

|                            |        |
|----------------------------|--------|
| A - 1CX400SQ.MM - KNOCKOUT | 3"     |
| B - 4CX300SQ.MM - KNOCKOUT | 2-3/4" |
| C - 4CX400SQ.MM - KNOCKOUT | 3-1/8" |
| D - 1CX300SQ.MM - KNOCKOUT | 1-1/2" |
| E - 4CX150SQ.MM - KNOCKOUT | 2"     |
| F - 4CX240SQ.MM - KNOCKOUT | 2-1/2" |
| G - 4CX95SQ.MM - KNOCKOUT  | 1-3/4" |
| h - 2CX65SQ.MM             | 3/4"   |
| 1 - 2CX105SQ.MM            | 1"     |

NOTES

1. DIMENSIONS AS SHOWN ARE IN MM
2. DRAWING NOT TO SCALE.
3. CORRECT CABLE GLAND SIZE TO BE USED ACCORDINGLY WITH CABLE SIZE

|  |   |                  |
|--|---|------------------|
|  <p><b>BHUTAN POWER CORPORATION LIMITED</b></p> | ENGINEERING DESIGN & CONTRACTS DEPARTMENT           |                  |
|  | TITLE : DISTRIBUTION DESIGN & CONSTRUCTION STANDARD |                  |
| 6WAYS TRANSFORMER DISTRIBUTION PILLAR (GLAND PLATE DETAILS)  |   |                  |
| DESIGNATION  | NAME  | DATE             |
| DRAFTSMAN  |   |                  |
| DESIGNER   |   |                  |
| DESIGN CHECK   |   |                  |
| PROJECT MANAGER  |   |                  |
| PROJECT DIRECTOR   |   |                  |
| DRAWING NO. BPC-DDCS-2015-57/4   |   | REVISION<br>2015 |

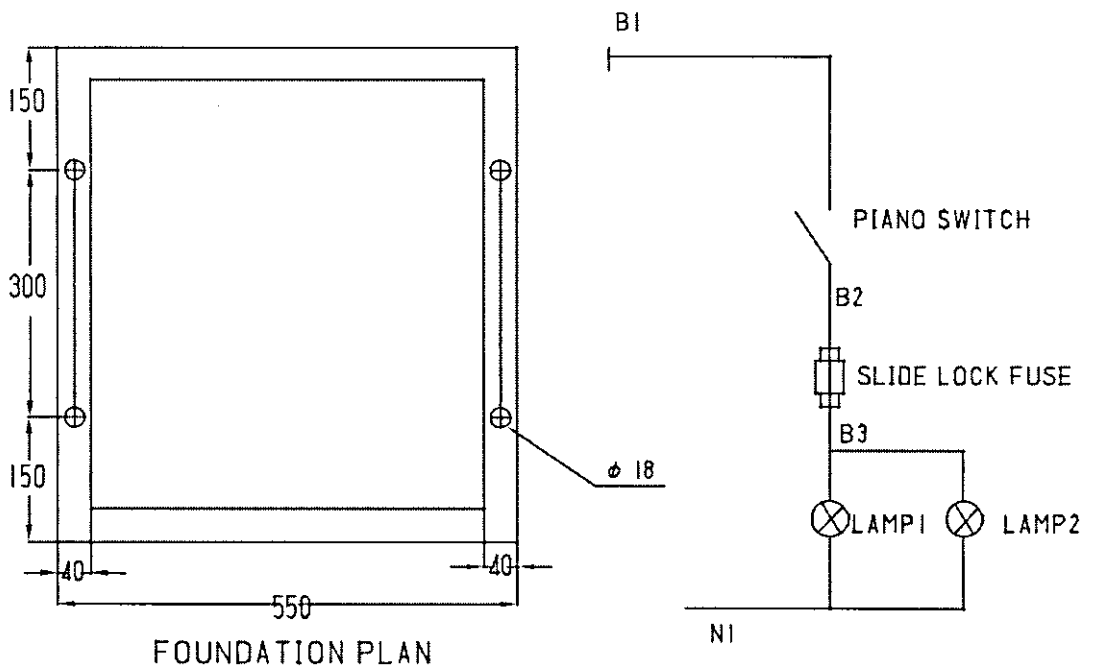

FOUNDATION PLAN

NOTES:  
 PHASE - 50X10MM AL - 3NOS.  
 NEUTRAL - 50X10MM AL - 1 NO. MATERIAL - THE FEEDER PILLAR (INCLUDING  
 BASE CHANNEL) SHALL BE FABRICATED OUT OF 2.5MM MS SHEET.  
 PAINT - SEIMENS GREY.  
 EARTH - 1X6X19MM, AL ALLOY.

NOTES  
 1. DIMENSIONS AS SHOWN ARE IN MM  
 2. DRAWING NOT TO SCALE.

|   |   |   |                                |
|---|---|---|--------------------------------|
|  | <b>BHUTAN POWER CORPORATION LIMITED</b> | ENGINEERING DESIGN & CONTRACTS DEPARTMENT                                   |                                |
|   |   | TITLE : DISTRIBUTION DESIGN & CONSTRUCTION STANDARD                         |                                |
|   |   | 6WAYS TRANSFORMER DISTRIBUTION PILLAR (FOUNDATION DETAILS AND LIGHTING CKT) |                                |
| DESIGNATION   | NAME                                    | DATE  | DRAWING NO. BPC-DDCS-2015-57/5 |
| DRAFTSMAN   |   |   |                                |
| DESIGNER  |   |   |                                |
| DESIGN CHECK  |   |   |                                |
| PROJECT MANAGER   |   |   |                                |
| PROJECT DIRECTOR  |   |   | REVISION<br>2015               |

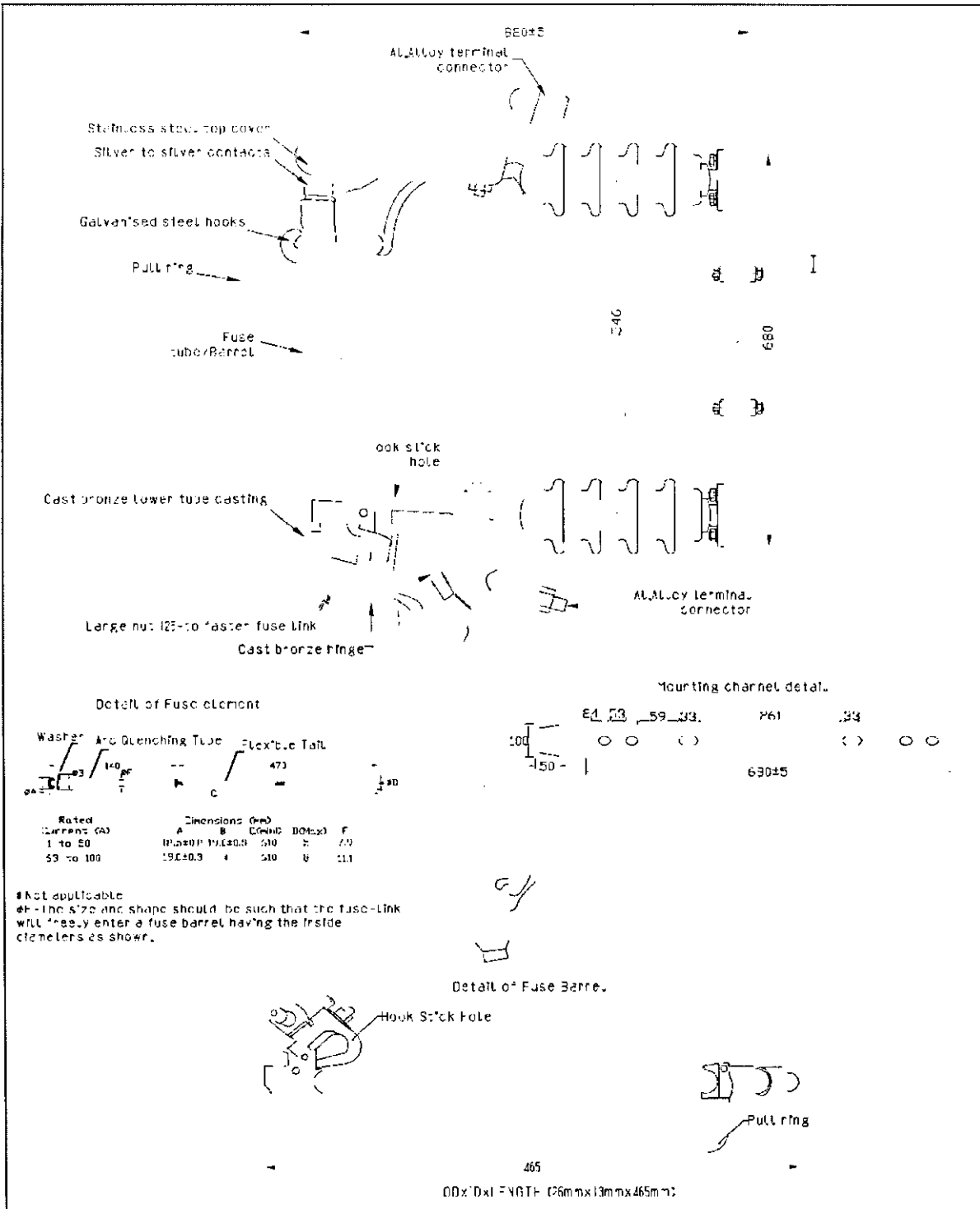

| <p><b>BHUTAN POWER CORPORATION LIMITED</b></p>   | <b>ENGINEERING DESIGN &amp; CONTRACTS DEPARTMENT</b>           |      |      |           |  |  |          |  |  |              |  |  |                 |  |  |                  |  |  |                              |                  |
|--|--|------|------|-----------|--|--|----------|--|--|--------------|--|--|-----------------|--|--|------------------|--|--|------------------------------|------------------|
|  | <b>TITLE : DISTRIBUTION DESIGN &amp; CONSTRUCTION STANDARD</b> |      |      |           |  |  |          |  |  |              |  |  |                 |  |  |                  |  |  |                              |                  |
| <b>Details of 11 kV and 33 kV Fuse Cut-out</b>   |  |      |      |           |  |  |          |  |  |              |  |  |                 |  |  |                  |  |  |                              |                  |
| <table border="1"> <thead> <tr> <th>DESIGNATION</th> <th>NAME</th> <th>DATE</th> </tr> </thead> <tbody> <tr> <td>DRAFTSMAN</td> <td></td> <td></td> </tr> <tr> <td>DESIGNER</td> <td></td> <td></td> </tr> <tr> <td>DESIGN CHECK</td> <td></td> <td></td> </tr> <tr> <td>PROJECT MANAGER</td> <td></td> <td></td> </tr> <tr> <td>PROJECT DIRECTOR</td> <td></td> <td></td> </tr> </tbody> </table> | DESIGNATION  | NAME | DATE | DRAFTSMAN |  |  | DESIGNER |  |  | DESIGN CHECK |  |  | PROJECT MANAGER |  |  | PROJECT DIRECTOR |  |  | DRAWING NO. BPC-DDCS-2015-58 | REVISION<br>2015 |
| DESIGNATION  | NAME   | DATE |      |           |  |  |          |  |  |              |  |  |                 |  |  |                  |  |  |                              |                  |
| DRAFTSMAN  |  |      |      |           |  |  |          |  |  |              |  |  |                 |  |  |                  |  |  |                              |                  |
| DESIGNER   |  |      |      |           |  |  |          |  |  |              |  |  |                 |  |  |                  |  |  |                              |                  |
| DESIGN CHECK   |  |      |      |           |  |  |          |  |  |              |  |  |                 |  |  |                  |  |  |                              |                  |
| PROJECT MANAGER  |  |      |      |           |  |  |          |  |  |              |  |  |                 |  |  |                  |  |  |                              |                  |
| PROJECT DIRECTOR   |  |      |      |           |  |  |          |  |  |              |  |  |                 |  |  |                  |  |  |                              |                  |

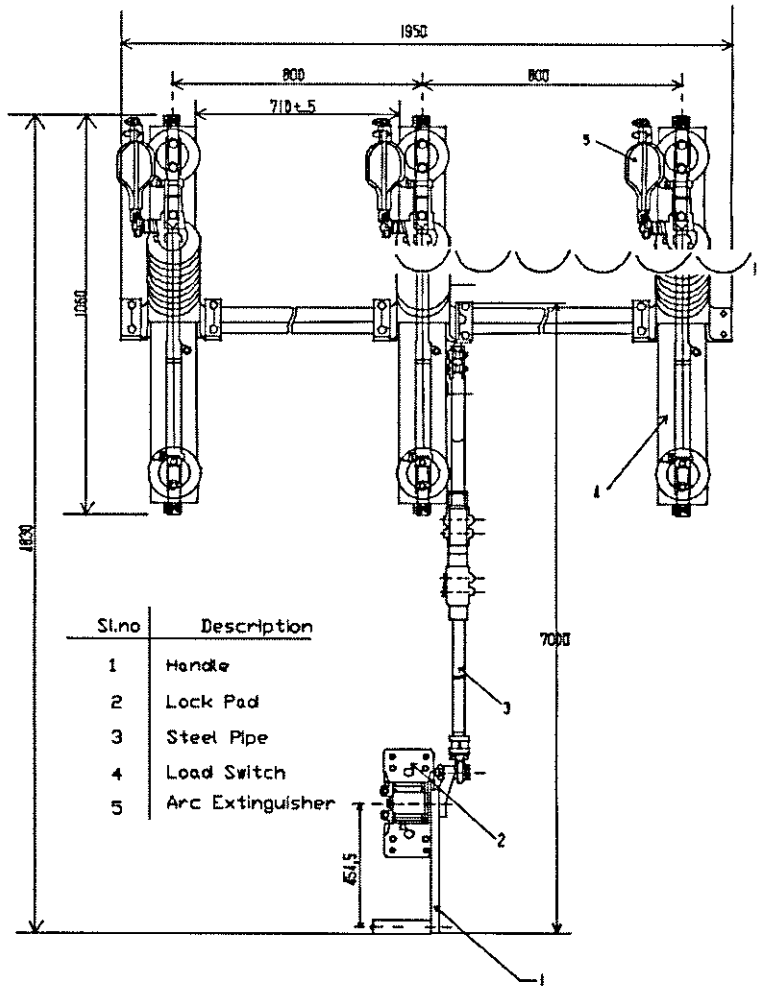
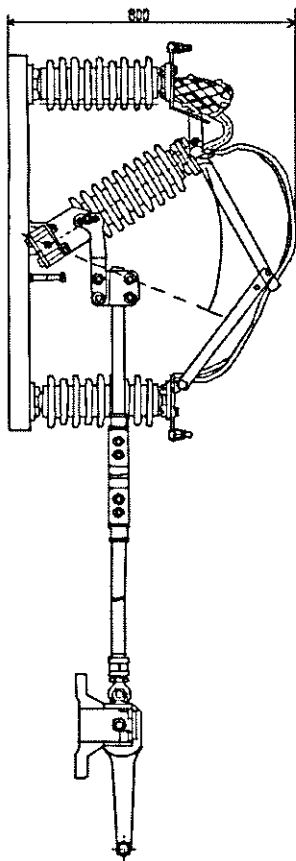

| Sl.no | Description      |
|-------|------------------|
| 1     | Handle           |
| 2     | Lock Pad         |
| 3     | Steel Pipe       |
| 4     | Load Switch      |
| 5     | Arc Extinguisher |

Rated Voltage:  
 Rated short time Withstand current for 1 sec.  
 Current Rating:  
 Diameter and Length of the GI operating Pipe  
 Size & Length of the channel for mounting  
 Minimum clearances between phases  
 Type of mounting  
 Power frequency withstand Voltage  
 1) Across Isolating Distance  
 2) To earth and between poles  
 Lightning Impulse withstand Voltage  
 1) Across Isolating Distance  
 2) To earth and between poles  
 Type of Insulator

|  |   |
|--|---|
| 11kV<br>20kA<br>63CA<br>25mm NBx6 mtr. Length<br>75mmx40mmx660mm Long<br>800mm<br>vertical | 33kV<br>16kA<br>63DA<br>32mmx7 mtr. Length<br>75mmx40mmx660mm Long<br>800mm<br>vertical |
| 32kV<br>28kV   | 80kV<br>70kV  |
| 89kV<br>79kV   | 195kV<br>170kV  |
| Post Type with alternating shed  | Post type with alternating shed   |

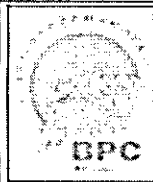

BHUTAN POWER CORPORATION LIMITED

ENGINEERING DESIGN & CONTRACTS DEPARTMENT

TITLE : DISTRIBUTION DESIGN & CONSTRUCTION STANDARD

Typical Arrangement of 11kV & 33kV LBS/ABS

| DESIGNATION      | NAME | DATE |
|------------------|------|------|
| DRAFTSMAN        |      |      |
| DESIGNER         |      |      |
| DESIGN CHECK     |      |      |
| PROJECT MANAGER  |      |      |
| PROJECT DIRECTOR |      |      |

DRAWING NO. BPC-DCCS-2015-59

REVISION

Distribution design and construction standards | 205

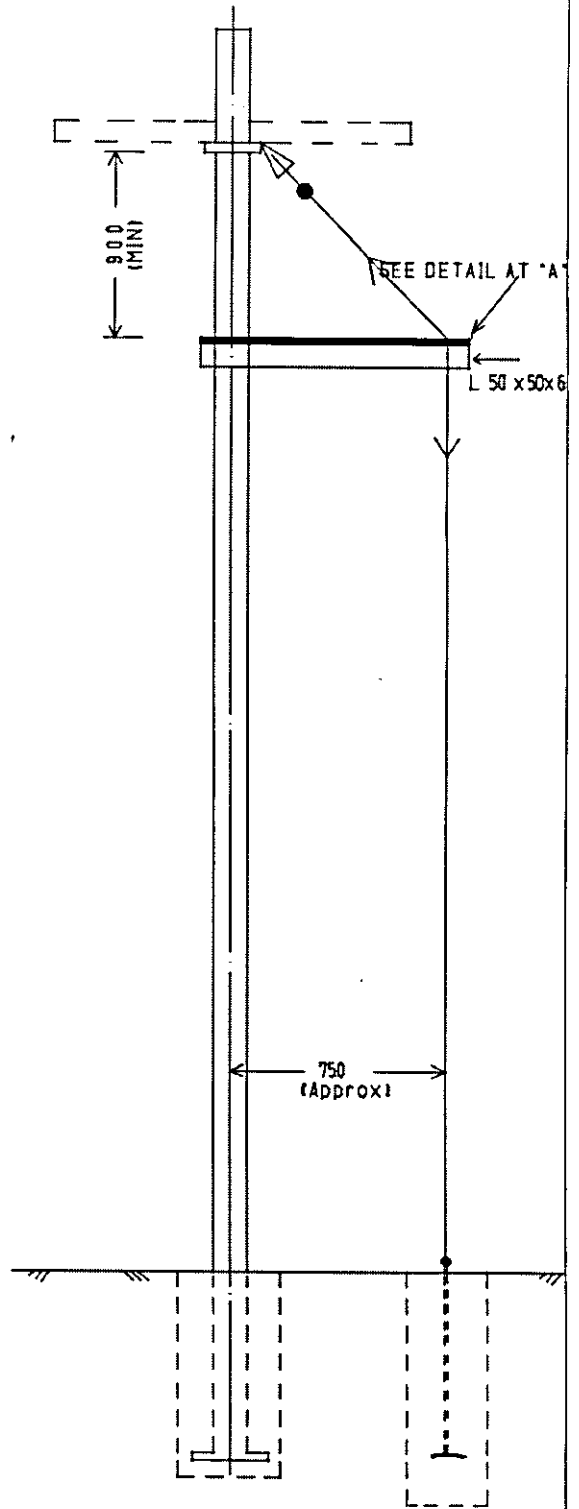
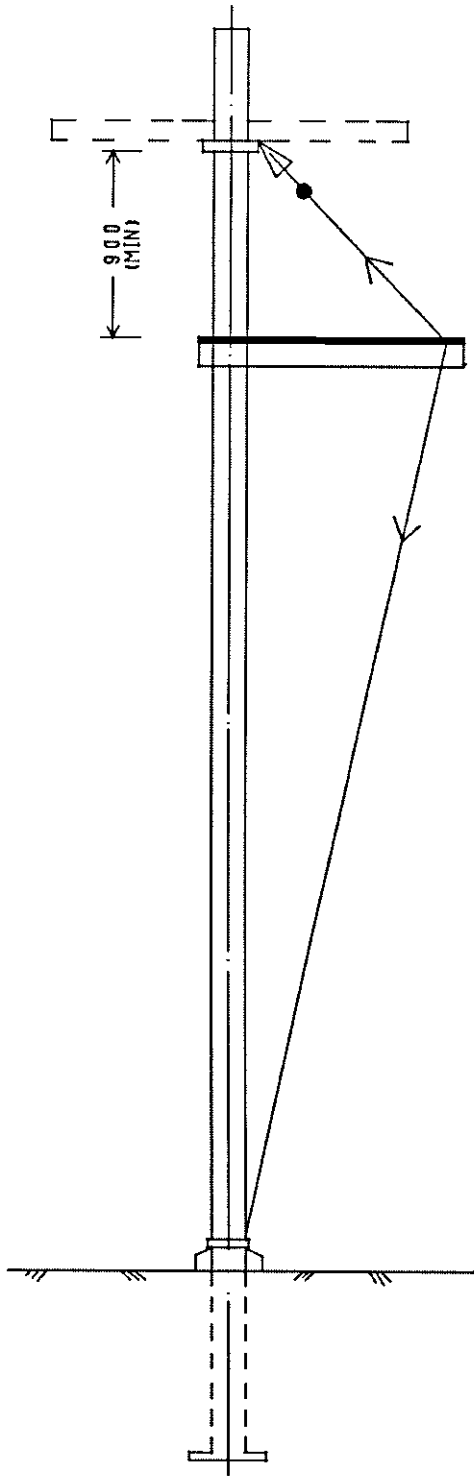

BHUTAN POWER CORPORATION LIMITED

ENGINEERING DESIGN & CONTRACTS DEPARTMENT

DISTRIBUTION DESIGN & CONSTRUCTION STANDARD

ARRANGEMENT OF BOW-GUY

| DESIGNATION      | NAME | DATE |
|------------------|------|------|
| DRAFTSMAN        |      |      |
| DESIGNER         |      |      |
| DESIGN CHECK     |      |      |
| PROJECT MANAGER  |      |      |
| PROJECT DIRECTOR |      |      |

DRAWING NO. BPC-DDCS-2015-60/1

REVISION  
2015

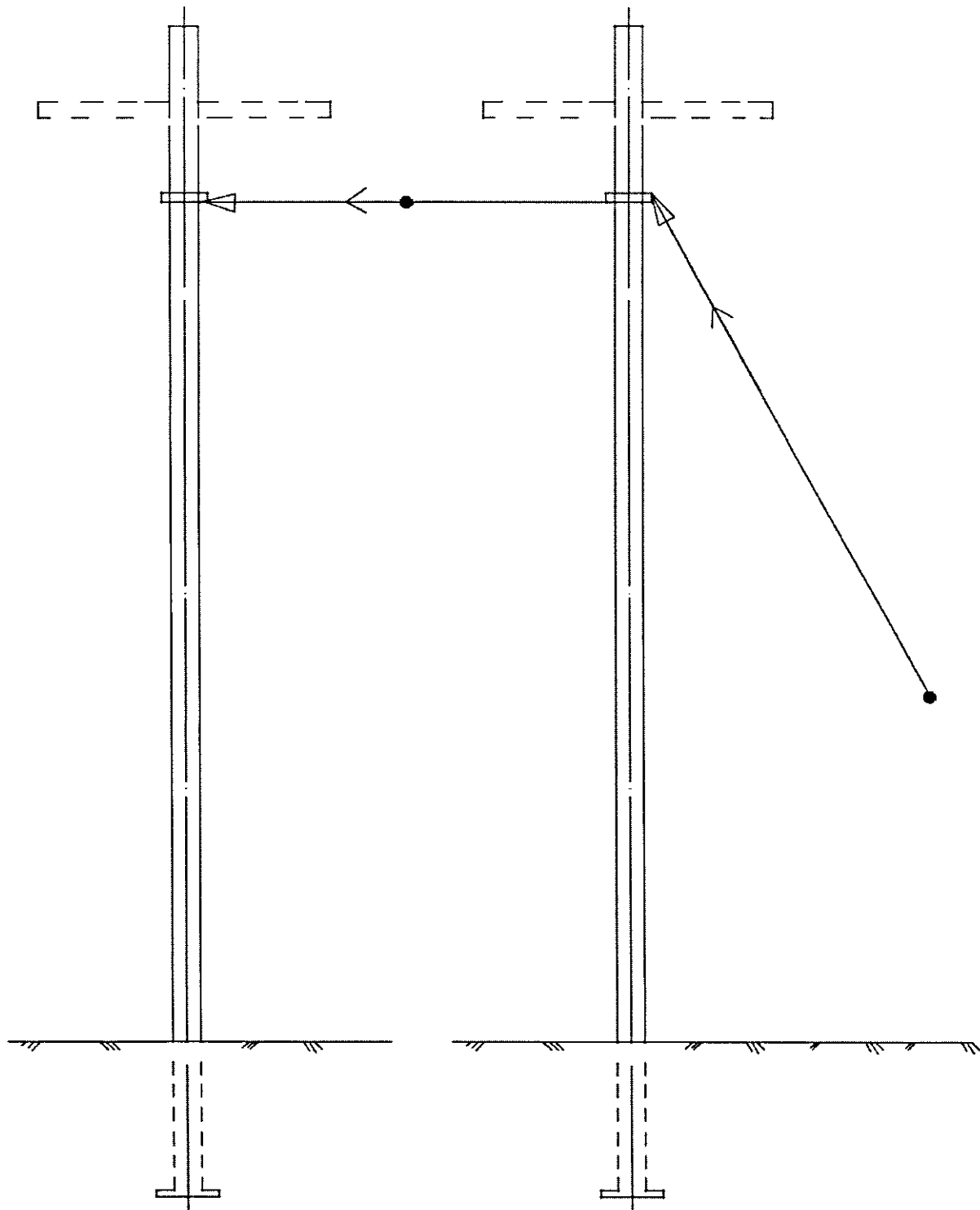

BHUTAN POWER CORPORATION LIMITED

ENGINEERING DESIGN & CONTRACTS DEPARTMENT

DISTRIBUTION DESIGN & CONSTRUCTION STANDARD

ARRANGEMENT OF FLY-GUY

| DESIGNATION      | NAME | DATE |
|------------------|------|------|
| DRAFTSMAN        |      |      |
| DESIGNER         |      |      |
| DESIGN CHECK     |      |      |
| PROJECT MANAGER  |      |      |
| PROJECT DIRECTOR |      |      |

DRAWING NO. BPC-DDCS-2015-60/2

REVISION  
2015

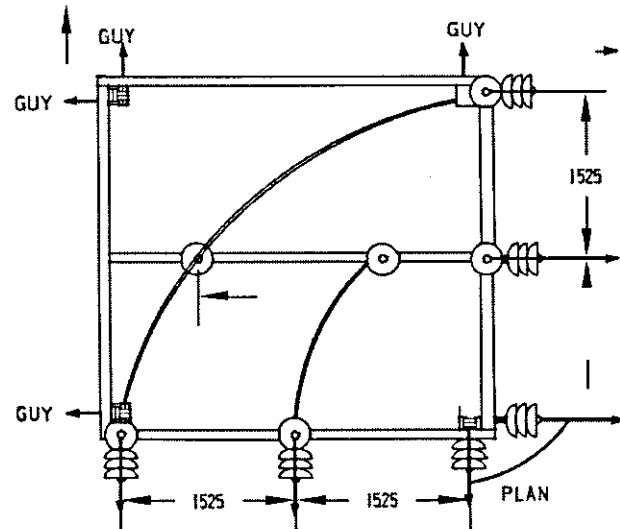
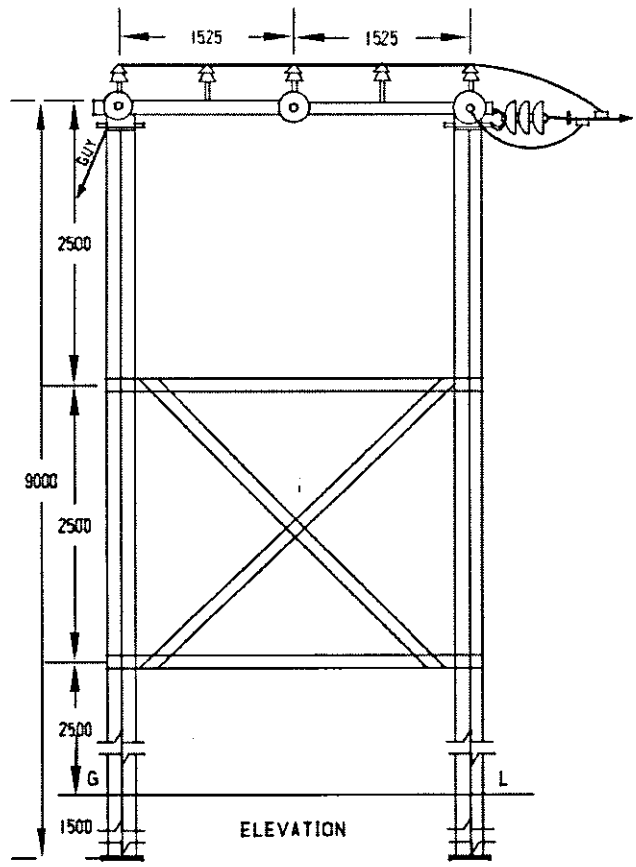

**BILL OF MATERIAL**

|                              |          |
|------------------------------|----------|
| SUPPORT 9.0M                 | 4 Nos.   |
| " " " "                      | 6 Nos.   |
| 33kV DISC INSULATORS         | 6 SETs   |
| SCAFFOLDING 100x50x6x150     | 5 Nos.   |
| 50x50x6 PLACING              | 8 Nos.   |
| " " " "                      | 8 Nos.   |
| EARTHING MATERIAL            | AS REOD. |
| NUTS, BOLTS, POLE CLAMPS ETC | AS REOD. |
| BASE PLATE                   | 4 Nos.   |
| GUY SET                      | 4 Nos.   |

ALL DIMENSION ARE IN mm

**BHUTAN POWER CORPORATION LIMITED**

| DESIGNATION      | NAME | DATE |
|------------------|------|------|
| DRAFTSMAN        |      |      |
| DESIGNER         |      |      |
| DESIGN CHECK     |      |      |
| PROJECT MANAGER  |      |      |
| PROJECT DIRECTOR |      |      |

**ENGINEERING DESIGN & CONTRACTS DEPARTMENT**

**TITLE : DISTRIBUTION DESIGN & CONSTRUCTION STANDARD**

**ARRANGEMENT OF CONDUCTORS AT ANGLE LOCATIONS - FOUR POLE STRUCTURE (60° TO 90° DEVIATION)**

DRAWING NO. BPC-QDCS-2015-61

Distribution design and construction standards | 208

REVISION

2015

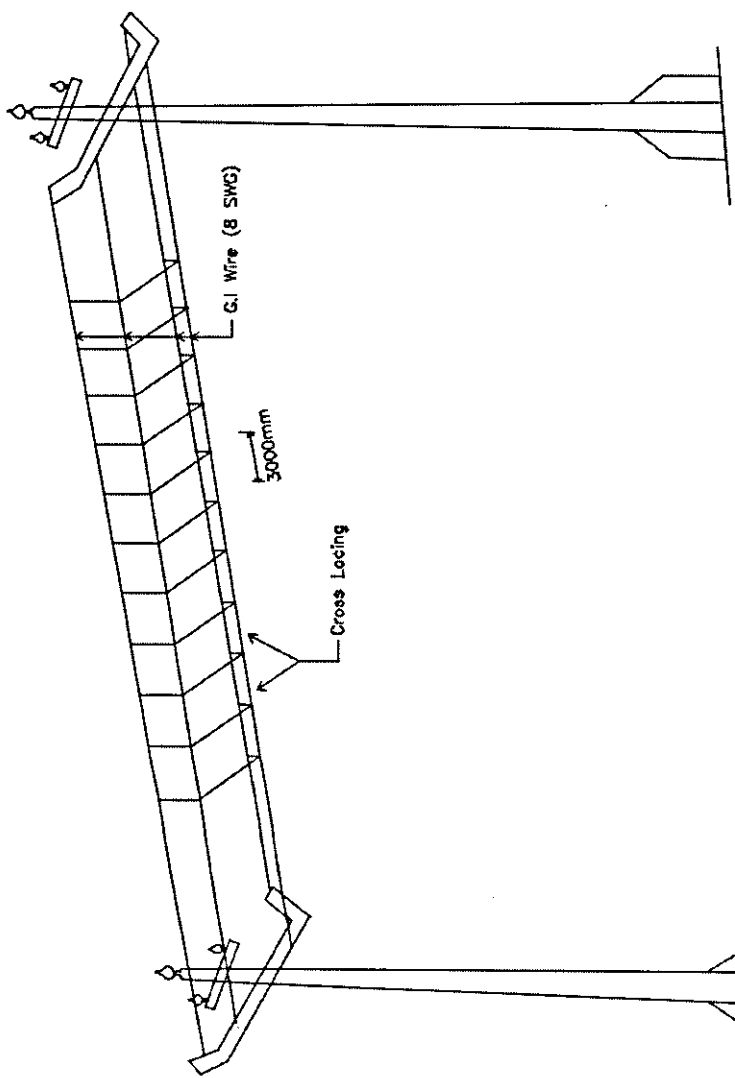

Cradle Type Guarding

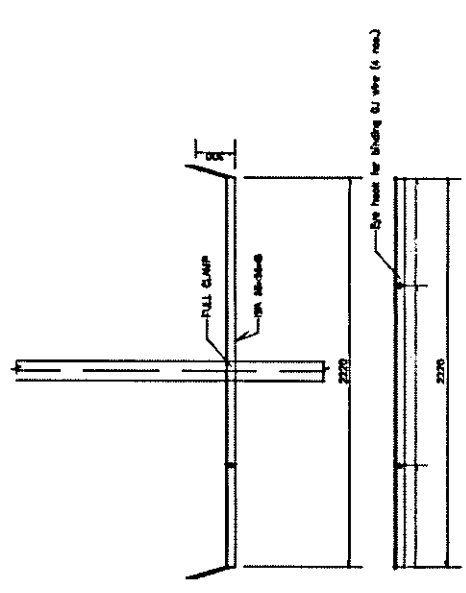

SINGLE POLE GUARD ARM

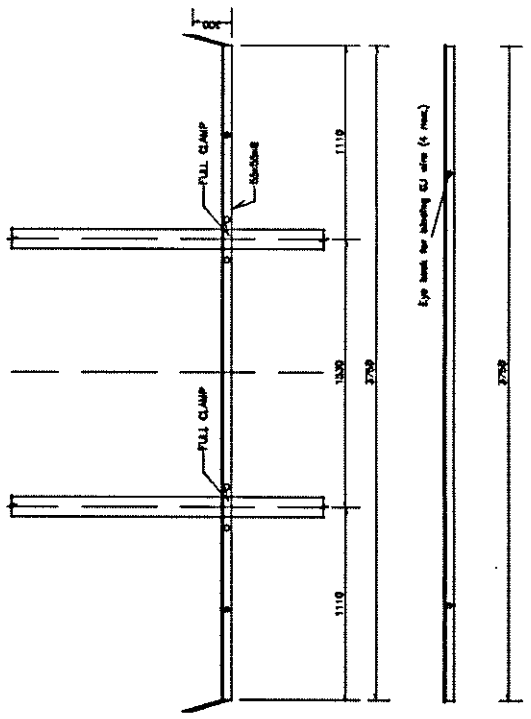

DOUBLE POLE GUARD ARM FOR IS POLE

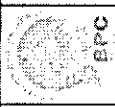
|   |                                  |      |   |
|---|----------------------------------|------|---|
|  | BHUTAN POWER CORPORATION LIMITED |      | ENGINEERING & DESIGN AND CONTRACTS DEPARTMENT |
|   | TITLE                            | NAME | DATE  |
| DESIGNED BY   |                                  |      |   |
| CHECKED BY  |                                  |      |   |
| APPROVED BY   |                                  |      |   |
| DRAWING NO. BPC-DDCS-2015-62  |                                  |      | REVISION 2015                                 |

DISTRIBUTION DESIGN & CONSTRUCTION STANDARD  
 INDICATIVE DRAWING OF GUARDING FOR 11 & 33 KV SYSTEM FOR IS POLE



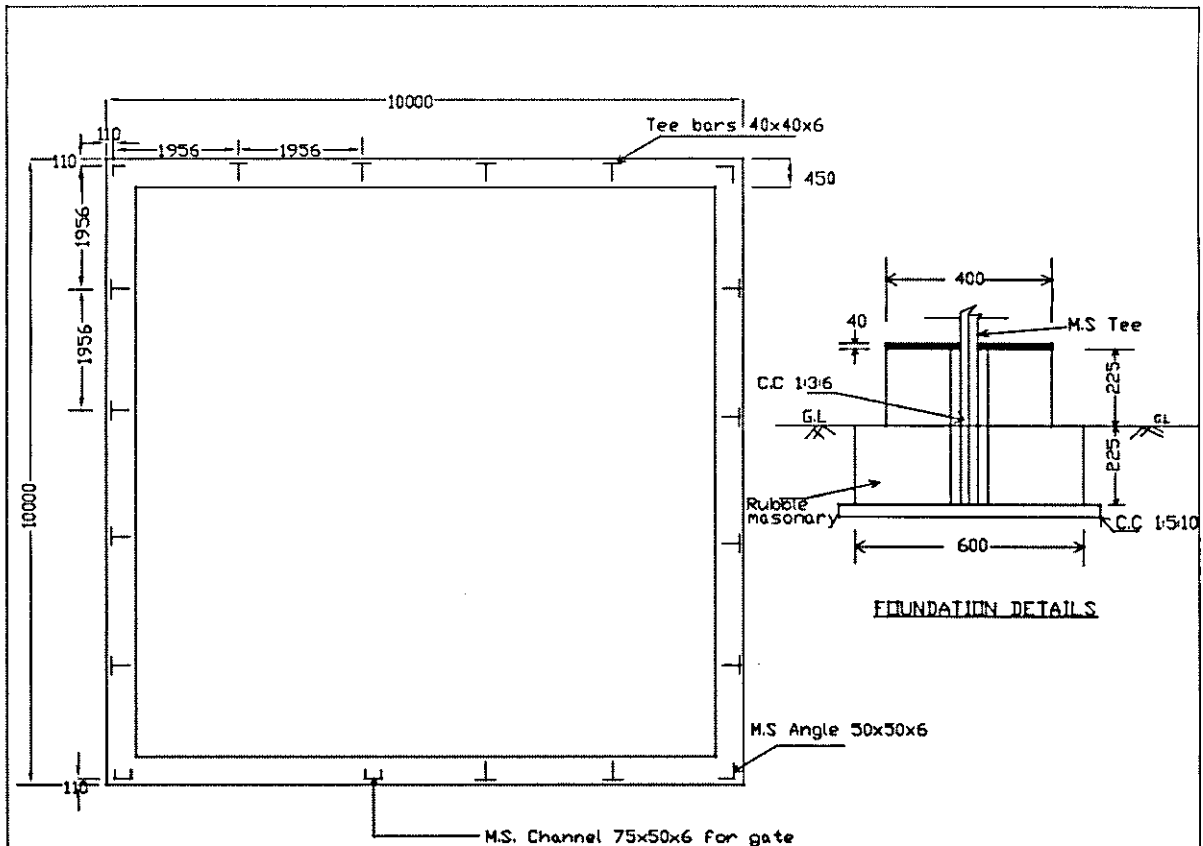

PLAN  
TRANSFORMER YARD FENCING 10M x 10M (N.T.S)

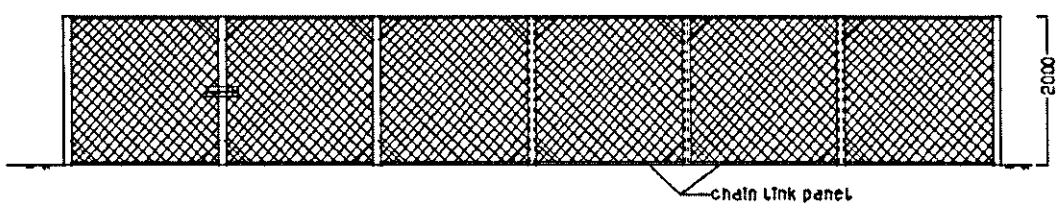

ELEVATION

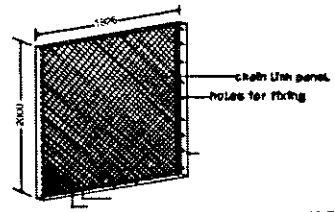

UNEQUAL ANGLE (40x75x5)

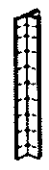

M.S. TEE (40x40x6x2000)

|  |   |      |  |                  |
|--|---|------|--|------------------|
|  | <b>BHUTAN POWER CORPORATION LIMITED</b> |      | <b>ENGINEERING DESIGN &amp; CONTRACTS DEPARTMENT</b>           |                  |
|  |   |      | <b>TITLE : DISTRIBUTION DESIGN &amp; CONSTRUCTION STANDARD</b> |                  |
| <b>CHAIN LINK FENCING FOR SUBSTATION (10 m x 10 m)</b> |   |      |  |                  |
| DESIGNATION  | NAME                                    | DATE | DRAWING NO. BPC-DDCS-2015-63                                   | REVISION<br>2015 |
| DRAFTSMAN  |   |      |  |                  |
| DESIGNER   |   |      |  |                  |
| DESIGN CHECK   |   |      |  |                  |
| PROJECT MANAGER  |   |      |  |                  |
| PROJECT DIRECTOR                                       |   |      |  |                  |

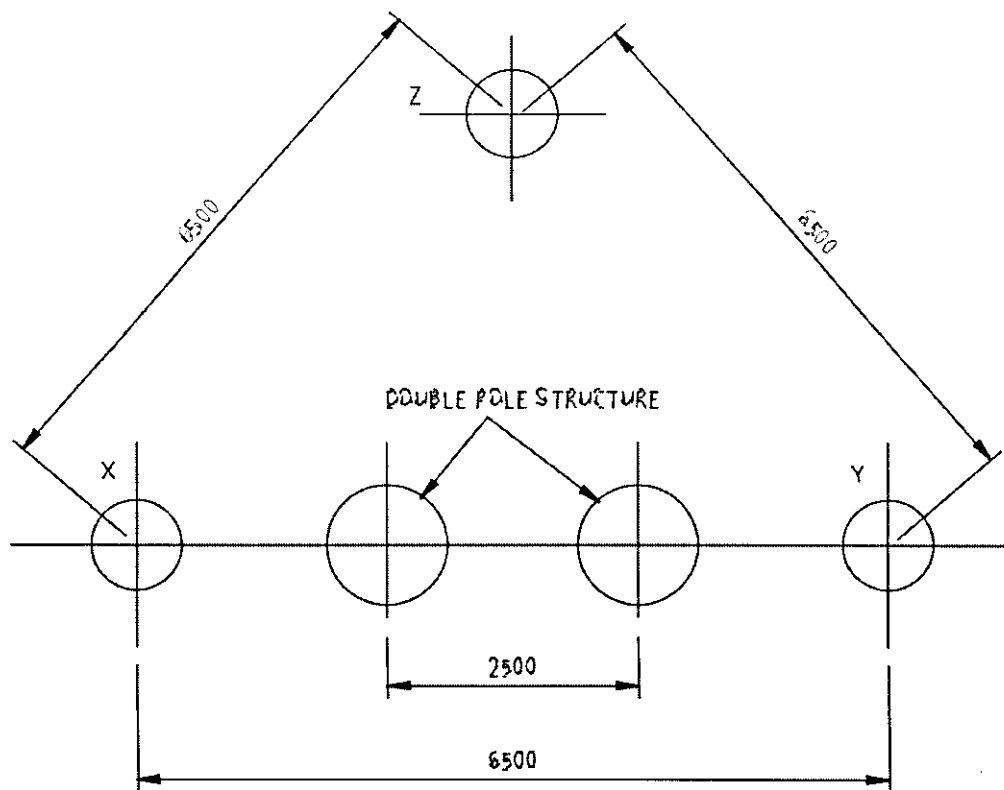

**NOTES**

1. THE CONNECTIONS TO THE THREE EARTH ELECTRODES SHOULD BE AS FOLLOWS:
  - a. TO ONE OF THE EARTH ELECTRODES ON EITHER SIDE OF DOUBLE POLE STRUCTURE ( X-Y )  
ONE DIRECT CONNECTION FROM 33kV OR 11kV NEUTRAL LIGHTNING ARRESTERS AND TRANSFORMER TANK
  - b. TO EACH OF THE REMAINING TWO EARTH-ELECTRODES
    - ( i ) ONE SEPARATE CONNECTION FROM THE NEUTRAL OF THE LOW VOLTAGE SIDE OF THE TRANSFORMER.
    - ( ii ) ONE SEPARATE CONNECTION FROM TERMINAL EARTH OF TRANSFORMER LT PANEL .
    - ( iii ) ONE SEPARATE CONNECTION FROM BODY OF TRANSFORMER LT PANEL .
2. 25 x 6 mm GALVANISED IRON STRAP LEADS.
3. THREE NOS. 40mm x 2500mm PIPE ELECTODES.
4. EARTH ELECTRODES X,Y AND Z TO BE BONDED TOGETHER USING 25x6mm GALVANISED IRON STRAP BURIED 100mm BELOW GROUND LEVEL.
5. REFER DWG BPC-DDCS-2015-66 FOR EARTH POINTS ON TRANSFORMER AND STRUCTURE.



**BHUTAN POWER CORPORATION LIMITED**

**ENGINEERING DESIGN & CONTRACTS DEPARTMENT**

**TITLE : DISTRIBUTION DESIGN & CONSTRUCTION STANDARD**

**33 KV OR 11 KV / 415 V DISTRIBUTION SUB-STATION  
PIPE EARTHING**

| DESIGNATION      | NAME | DATE |
|------------------|------|------|
| DRAFTSMAN        |      |      |
| DESIGNER         |      |      |
| DESIGN CHECK     |      |      |
| PROJECT MANAGER  |      |      |
| PROJECT DIRECTOR |      |      |

DRAWING NO. BPC-DDCS-2015-64

REVISION  
2015

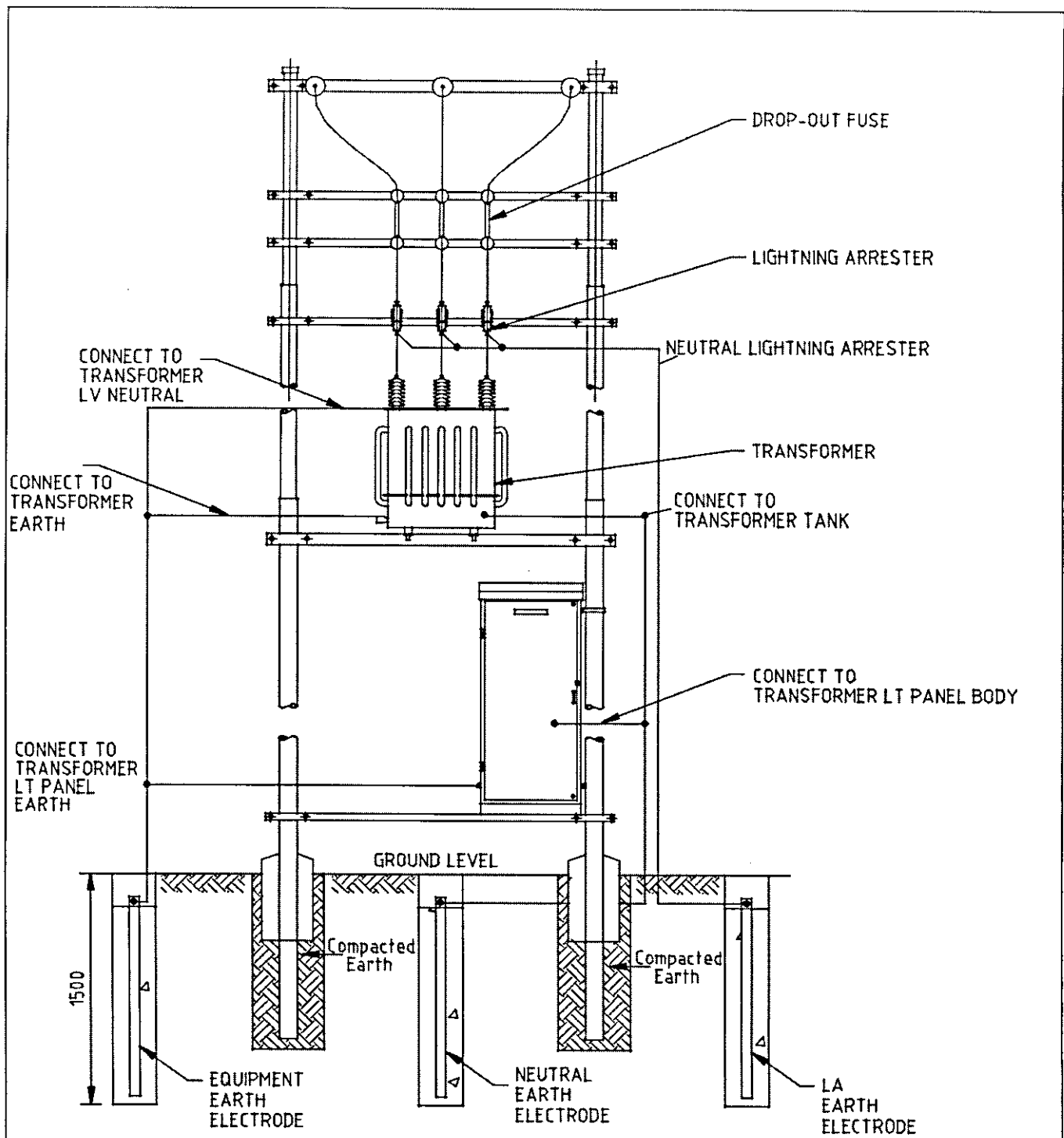

**NOTES**

1. DIMENSIONS AS SHOWN ARE IN mm.
2. DRAWING IS NOT TO SCALE.
3. EARTH CONDUCTOR IS 25 x 6 MS FLAT



**BHUTAN POWER CORPORATION LIMITED**

**ENGINEERING DESIGN & CONTRACTS DEPARTMENT**

**TITLE : DISTRIBUTION DESIGN & CONSTRUCTION STANDARD**  
**DISTRIBUTION SUBSTATION TYPICAL EARTHING SCHEME ARRANGEMENT**

| DESIGNATION      | NAME | DATE |
|------------------|------|------|
| DRAFTSMAN        |      |      |
| DESIGNER         |      |      |
| DESIGN CHECK     |      |      |
| PROJECT MANAGER  |      |      |
| PROJECT DIRECTOR |      |      |

DRAWING NO. BPC-DDCS-2015-65

REVISION  
2015

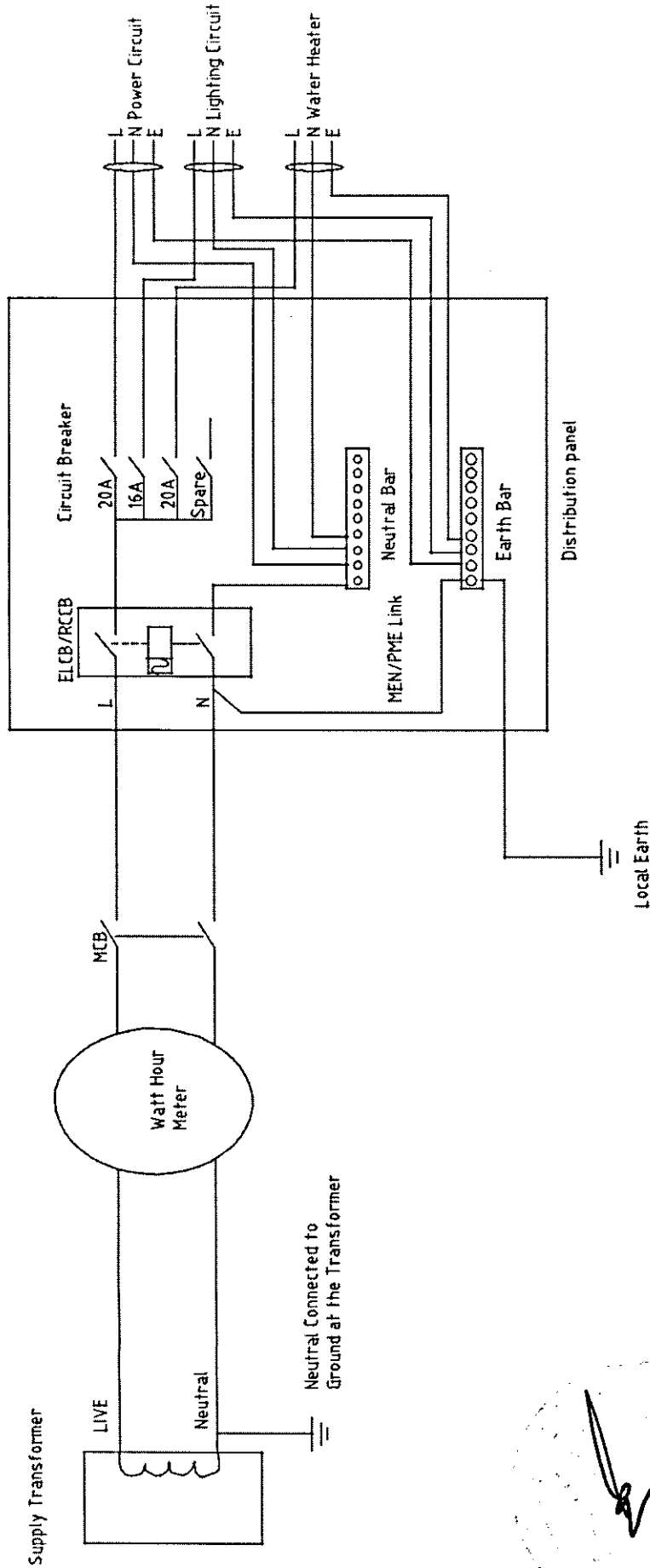

Alternative neutral earth connection where RCCB is used.

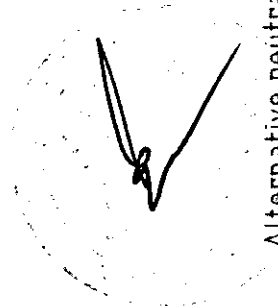

|                                   |                                  |      |   |  |
|-----------------------------------|----------------------------------|------|---|--|
|                                   | BHUTAN POWER CORPORATION LIMITED |      | ENGINEERING & DESIGN AND CONTRACTS DEPARTMENT |  |
|                                   | TITLE                            | NAME | DATE  |  |
| DESIGNED BY                       |                                  |      |   |  |
| CHECKED BY                        |                                  |      |   |  |
| APPROVED BY                       |                                  |      |   |  |
| DRAWING NO. BPC - DDCCS - 2015-66 |                                  |      | REVISION 2015                                 |  |

**SECTION V**  
**PRICE SCHEDULES**



## PRICE SCHEDULE

**Construction of 33 kV line with ACSR, DOG conductor and shield wire on Telescopic pole at Bondheyima, Mongar Dzongkhag**

| Sl # | Work Description   | Unit | Quantity | Rate | Amount |
|------|--|------|----------|------|--------|
|      | <b>Overhead Medium Voltage Lines</b>   |      |          |      |        |
| A    | Detailed route survey, clearing of jungle, bushes, felling of trees including cutting of trunks and branches and removing of trees along the right of Way (RoW) rivers, road and foot path, transportation of material (both headloading both vehiculars) digging of holes for poles, erection, stringing of conductors, <b>stringing of shield wire</b> , fittings and other accessories including testing, commissioning and other associated works as required. |      |          |      |        |
| 1    | Construction of 33 kV ACSR, 3 phase, 4 Wire with DOG conductor   | km   | 15.00    |      |        |
|      | <b>Total price (Nu)</b>  |      |          |      | -      |
|      | <b>In words</b>  |      |          |      |        |

*Note:*

*The quantities mentioned here are indicative and are estimated values. These are subject to change at the time of execution. Payments shall be made based on the actual volume of works at the rate or price schedule of the contract*



## PRICE SCHEDULE

**Construction of 33 kV line with ACSR, DOG conductor and shield wire on Telescopic pole at Pemathang in Samdrup Jongkhar Dzongkhag**

| Sl # | Work Description   | Unit | Quantity | Rate | Amount |
|------|--|------|----------|------|--------|
|      | <b>Overhead Medium Voltage Lines</b>   |      |          |      |        |
| A    | Detailed route survey, clearing of jungle, bushes, felling of trees including cutting of trunks and branches and removing of trees along the right of Way (RoW) rivers, road and foot path, transportation of material (both headloading both vehiculars) digging of holes for poles, erection, stringing of conductors, <b>stringing of shield wire</b> , fittings and other accessories including testing, commissioning and other associated works as required. |      |          |      |        |
| 1    | Construction of 33 kV ACSR, 3 phase, 4 Wire with DOG conductor   | km   | 21.00    |      |        |
|      | <b>Total price (Nu)</b>  |      |          |      | -      |
|      | <b>In words</b>  |      |          |      |        |

*Note:*

*The quantities mentioned here are indicative and are estimated values. These are subject to change at the time of execution. Payments shall be made based on the actual volume of works at the rate or price schedule of the contract*

**SECTION VI**  
**BID FORM**





**SECTION VI**

**BID FORM**

To: General Manager,  
Distribution Construction Department,  
Bhutan Power Corporation Limited,  
Thimphu: Bhutan.

Gentlemen:

1. We have examined and have no reservation to the Bidding Documents including the addenda No :
2. We offer to execute in conformity with the Bidding Documents and in accordance with the completion schedule specified in the Bidding Documents.
3. The Total Price of our Bid, excluding any discounts offered in item (4) below is:  
.....  
.....
4. The discounts offered and the methodology for their application are:  
.....  
.....
5. We undertake, if our Bid is accepted, to complete the works within stipulated days in the terms and conditions of the bidding document and calculated from the date of site handing over.
6. If our Bid is accepted, we will provide the performance security in the sum of (Amount)....., equal to **(10)** per cent of the Contract price, for the due performance of the Contract.  
Our Bid shall be valid for a period of **90** days (till September 22, 2021) from the date fixed for the bid submission deadline in accordance with Bidding Documents and it shall remain binding upon us and may be accepted at any time before expiration of that period.
7. We are not participating, as Bidders, in more than one Bid in this bidding process, other than alternative offers in accordance with the Bidding Documents.
8. We understand that this Bid, together with your written acceptance thereof in your Notification of Award, shall constitute a binding Contract between us, until a formal contract is executed.
9. We understand that you are not bound to accept the lowest-priced of any Bid that you may receive.

Dated this \_\_\_\_\_ day of \_\_\_\_\_, 2021.

\_\_\_\_\_ (Signature)

\_\_\_\_\_ (in the Capacity of)

Duly authorized to sign Bid for and on behalf of \_\_\_\_\_

\_\_\_\_\_ (Signature of Witness)

Witness \_\_\_\_\_

Address \_\_\_\_\_

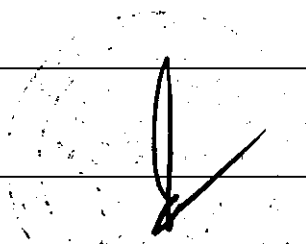

**SECTION VII**  
**OTHER FORMS**

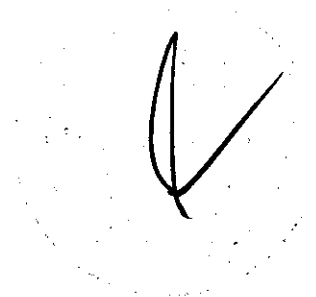

## **SECTION VII**

1. Bid Security Form
2. Contract Form
3. Performance Security Form
4. Advance Payment Security Form
5. Form of Information for Establishment of Bidder's Eligibility.
6. Form of Information for Establishment of Bidder's Qualification.
7. Confirmation of Litigation History
8. Average Performance Scoring form

A handwritten mark or signature, possibly a stylized 'V' or a checkmark, located in the lower right quadrant of the page.

## 1. Bid Security Form

WHEREAS \_\_\_\_\_ [Name of Bidder] (Hereinafter called "the Bidder") has submitted its Bid dated \_\_\_\_\_ [Date] for the construction of \_\_\_\_\_ (Name of the package) (hereinafter called "the Bid").

**KNOW ALL MEN by these presents that WE \_\_\_\_\_ [Name of Bank] of \_\_\_\_\_ [Name of Country] having our registered office at \_\_\_\_\_ (hereinafter called "the Bank") and bound unto Bhutan Power Corporation Limited (hereinafter called the Employer) in the sum of Nu. \_\_\_\_\_ (Words**

\_\_\_\_\_), for which payment well and truly to be made to the said Employer, the Bank binds itself, its successor and assigns, by these present. Sealed with the Common Seal of the Bank this \_\_\_\_\_ day of \_\_\_\_\_, 2021.

THE CONDITIONS of this obligation are:

1. if the Bidder withdraws its Bid during the period of bid validity specified by the Bidder on the Bid form; or
2. if the Bidder does not accept the correction of arithmetical errors of his bid price in accordance with the instruction to Bidders; or
3. if the Bidder, having been notified of the acceptance of its Bid by the Employer during the period of bid validity:
  - (a) fails or refuses to execute the Contract Form, when requested; or
  - (b) fails or refuses to furnish the Performance Security, in accordance with the Instructions to Bidders;

We undertake to pay to the Employer up to the above amount, according to, and upon receipt of, its first written demand, without the Employer having to substantiate its demand, provided that in its demand the Employer will note that the amount claimed by it is due to it owing to the occurrence of one or both of the two above-stated conditions, specifying the occurred condition or conditions.

This guarantee will remain in force up to and including \_\_\_\_\_ days after the period of bid validity, and any demand in respect thereof should reach the Bank not later than such date.

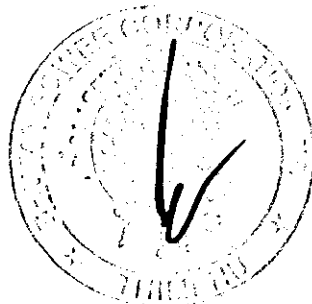

[NAME OF BANK]  
by  
(Title)  
Authorized representative

**2. Contract Form (To be use later)**

This Agreement made this \_\_\_\_\_ day of \_\_\_\_\_, 2021, between Bhutan Power Corporation Limited (hereinafter "the Employer") of the one part and \_\_\_\_\_ (hereinafter "the Contractor") of the other part.

WHEREAS THE Employer is desirous that certain works should be executed by the Contractor, viz. \_\_\_\_\_ and has accepted a Bid by the Contractor for the execution and completion of such works and remedying of any defects therein. (hereinafter "the Contract Price").

Now this agreement witnesseth as follows:

1. In this Agreement words and expressions shall have the same meanings as are respectively assigned to them in the Conditions of Contract hereinafter referred to.
2. The following documents shall be deemed to form and read and construed as part of this Agreement, viz:
  - (a) This Agreement;
  - (b) Letter of Acceptance;
  - (c) The said Bid;
  - (d) Conditions of Contract;
  - (e) The Specifications;
  - (f) The drawings;
  - (g) The Price Schedules; and
  - (h) The Schedules of Supplementary Information.

This Contract sets forth the entire contract and agreement between the parties pertaining to the Works described herein and supersedes any and all earlier verbal or written agreements pertaining to the Contract.

This Contract shall prevail over all other Contract documents. In the event of any discrepancy or inconsistency within the Contract documents, then the documents shall prevail in the order listed above.

3. In consideration of the payments to be made by the Employer to the Contractor as hereinafter mentioned, the Contractor hereby covenants with the Employer to execute and complete the Works and remedy any defects herein in conformity in all respects with the provisions of the Contract.
4. The Employer hereby covenants to pay the Contractor, in consideration of the execution and completion of the Works and the remedying of defects therein, the Contract Price or such other sum as may become payable under the provisions of the Contract, at the times and in the manner prescribed by the Contract.

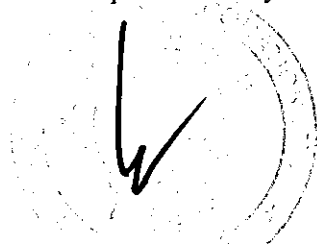
A handwritten signature in black ink is written over a circular stamp. The signature appears to be a stylized 'W' or similar character. The stamp is faint and circular, with some illegible text or a logo inside.

5. Any notice under this Contract shall be in the form of letter or facsimile. Notices to either party shall be given at such address or addresses as such party shall specify from time to time by written notice to the other. In the absence of such notice to the contrary, notice to the Employer shall be properly addressed to :

[Employer's address and electronic transmission address]

\_\_\_\_\_

and notice to the Contractor shall be properly addressed to:

[Contractor's address and electronic transmission address]

\_\_\_\_\_  
\_\_\_\_\_  
\_\_\_\_\_

A notice shall be effective when delivered or on the notice's effective date, whichever is later.

IN WITNESS WHEREOF, the parties hereto have caused this Contract to be executed in accordance with their respective laws the day and year first above written.

\_\_\_\_\_  
Signature of Employer

\_\_\_\_\_

Signature of Contractor

Signed, Sealed and Delivered by the said \_\_\_\_\_  
(For the Employer) in the presence of \_\_\_\_\_

Signed, Sealed and Delivered by the said \_\_\_\_\_ (for the  
Contractor) in the presence of \_\_\_\_\_



### 3. Performance Security Form

To: The Director,  
Finance & Accounts Services,  
Bhutan Power Corporation Limited,  
Yarden Lam, Post Box No.580,  
Thimphu : Bhutan.

WHEREAS (Name of the Contractor) hereinafter called "the Contractor", has undertaken, in pursuance of Contract No. \_\_\_\_\_ dated \_\_\_\_\_ to execute \_\_\_\_\_ (name of the Contract) (hereinafter called "Bid").

AND WHEREAS it has been stipulated by you in the said Contract that the Contractor shall furnish you with a Bank Guarantee by a recognized Bank for the sum specified therein as security for compliance with the Bidder's performance obligations in accordance with the Contract;

AND WHEREAS we have agreed to give the Contractor a Guarantee;

NOW THEREFORE we hereby affirm that we are Guarantors and responsible to you, on behalf of the Contractor, up to a total of (Amount of the Guarantee in Words and Figures) and we undertake to pay you, upon your first written demand declaring the Bidder to be in default under the Contract, and without cavil or argument, any sum or sums as specified by you, within the limit of (Amount of Guarantee) as aforesaid, without your needing to prove or to show grounds or reasons for your demand or the sum specified therein.

We hereby waive the necessity of your demanding the said debt from the Contractor before presenting us with the demand.

We further agree that no change or addition to or other modification of the terms of the Contract or of the Works to be performed thereunder or any way release us from any liability under this guarantee, and we hereby waive notice of any such change, addition or modification.

This guarantee is valid until \_\_\_\_\_ day of \_\_\_\_\_ 2021.

[NAME OF GUARANTOR]

By \_\_\_\_\_



(Title)  
Authorized Representative

Date: \_\_\_\_\_

Address: \_\_\_\_\_

#### 4. Advance Payment Security Form

To: The Director,  
Finance & Accounts Services,  
Bhutan Power Corporation Limited,  
Yarden Lam, Post Box No.580,  
Thimphu : Bhutan

[Name of Contract] \_\_\_\_\_

Gentlemen:

In accordance with the payment provision included in the Clause 45 of the Conditions of Contract to provide for advance payment, [name and address of Contractor] (hereinafter called "the Contractor") shall deposit with the Employer a bank guarantee to guarantee its proper and faithful performance under the said Clause of the Contract in an amount of *[amount of guarantee in figures and word]*.

We, the *[bank or financial institution]*, as instructed by the Contractor, agree unconditionally and irrevocably to guarantee as primary obligator and not as surety merely, the payment to the Employer on its first demand without whatsoever right of objection on our part and without its first claim to the Contractor, in the amount not exceeding *[amount of guarantee in figures and words.]*

We further agree that no change or addition to or other modification of the terms of the Contract to be performed thereunder or of any of the Contract documents which may be made between the Employer and the Contractor, shall in any way release us from any liability under this guarantee, and we hereby waive notice of any such change, addition, or modification.

This guarantee shall remain valid and in full effect from the date of the advance payment under the Contract until Bhutan Power Corporation Limited receives full repayment of the said amount from the Contractor.

Yours truly,

Signature and seal of the Guarantor: \_\_\_\_\_

\_\_\_\_\_  
[name of bank or financial institution]

\_\_\_\_\_  
[address]

\_\_\_\_\_  
[date]

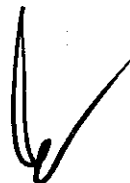



**5. Form of Information for Establishment of Bidder's Eligibility**

*The Bidder shall submit with the Bid a letter from Ministry of Economic Affairs validating the license and this Form to evidence the Bidder's eligibility (Refer to Clause 13 in Section II - Instructions to Bidders).*

|   |  |
|---|--|
| Name of Bidder:   |  |
| Class of License, registered for W4 in CDB              |  |
| CDB registration number                                 |  |
| Numbers of Work in Hand (as of the date of bid opening) |  |

*If the Bidder has any work in hand, the information on the contract of work(s) in hand, shall be provided in the table below for all the contract(s):*

***Contract No.1***

|                                  |  |
|----------------------------------|--|
| Name of Project or Contract      |  |
| Name of Employer/Client          |  |
| Date of award by Employer/Client |  |
| Date of completion scheduled     |  |

***Contract No.2***

|                                  |  |
|----------------------------------|--|
| Name of Project or Contract      |  |
| Name of Employer/Client          |  |
| Date of award by Employer/Client |  |
| Date of completion scheduled     |  |

***Contract No.3***

|                                  |  |
|----------------------------------|--|
| Name of Project or Contract      |  |
| Name of Employer/Client          |  |
| Date of award by Employer/Client |  |
| Date of completion scheduled     |  |

*Note: If the Bidder has more than 3 works in hand, the above table shall be added to describe all works in hand.*

Name of Bidder: \_\_\_\_\_

Signature of Bidder: \_\_\_\_\_



## 6. Form of Information for Establishment of Bidder's Qualification

*The Bidder shall submit with this Form to evidence the Bidder's qualification (Refer to Clause 14 in Section II - Instructions to Bidders).*

|                             |  |
|-----------------------------|--|
| Name of Bidder:             |  |
| Offered Package No./Lot No. |  |

### *List of Tools and Equipment*

| Tools and Equipment | Quantity in Possess |
|---------------------|---------------------|
|                     |                     |
|                     |                     |
|                     |                     |
|                     |                     |
|                     |                     |
|                     |                     |
|                     |                     |
|                     |                     |
|                     |                     |
|                     |                     |
|                     |                     |
|                     |                     |
|                     |                     |
|                     |                     |
|                     |                     |

Name of Bidder: \_\_\_\_\_

Signature of Bidder: \_\_\_\_\_

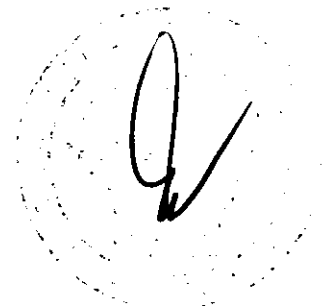

**List of Skilled Employee**

| Name of Employee | CID No. | Position for the Project | Years of Experience | Graduate |
|------------------|---------|--------------------------|---------------------|----------|
|                  |         |                          |                     |          |
|                  |         |                          |                     |          |
|                  |         |                          |                     |          |
|                  |         |                          |                     |          |
|                  |         |                          |                     |          |
|                  |         |                          |                     |          |
|                  |         |                          |                     |          |
|                  |         |                          |                     |          |
|                  |         |                          |                     |          |
|                  |         |                          |                     |          |

**List of Experience of Works done of Similar Nature**

| Name of Contract | Name of Employer | Completion Year | Contract Amount (Nu.)* |
|------------------|------------------|-----------------|------------------------|
|                  |                  |                 |                        |
|                  |                  |                 |                        |
|                  |                  |                 |                        |
|                  |                  |                 |                        |
|                  |                  |                 |                        |
|                  |                  |                 |                        |
|                  |                  |                 |                        |
|                  |                  |                 |                        |
|                  |                  |                 |                        |
|                  |                  |                 |                        |
|                  |                  |                 |                        |

*Note: \* Approximate contract amount shall be mentioned in Nu.*

Name of Bidder: \_\_\_\_\_

Signature of Bidder: \_\_\_\_\_



**7. Confirmation of Litigation History, if any.**

| <b>Litigation, if any</b> | <b>Parties involved</b> | <b>Year of litigation</b> | <b>Disputed amount</b> |
|---------------------------|-------------------------|---------------------------|------------------------|
|                           |                         |                           |                        |
|                           |                         |                           |                        |
|                           |                         |                           |                        |
|                           |                         |                           |                        |
|                           |                         |                           |                        |
|                           |                         |                           |                        |

Name of the Firm: \_\_\_\_\_

CDB Registration No. \_\_\_\_\_

\_\_\_\_\_  
Authorized Signatory\* with the company seal and Legal Stamp

\*Authorized signatory (If the signing authority is not the proprietor himself/herself, please attach the Power of Attorney duly authorized by the proprietor of the company).

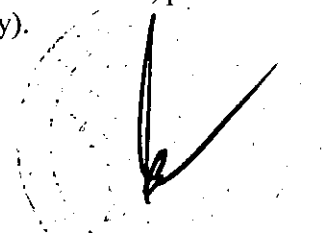
A handwritten signature in black ink is written over a circular stamp. The stamp is mostly illegible but appears to contain some text around the perimeter. The signature is a stylized, cursive-like name.

Construction Development Board  
Average Performance Scoring Form (CON03)

*(This report to be submitted on completion of contract to the e-tool focal person)*

Name of the Contractor:

CDB Number:

Name of the Client:

Name of the Project:

Name of Inspecting Engineer:

Award Amount:

Date of Start of Project:

Final Contract Amount:

Date of Completion:

**Performance Score Table:-**

| <i>Sl/No</i> | <i>Description</i>   | <i>Total Score</i> | <i>Score Obtained</i> |
|--------------|----------------------|--------------------|-----------------------|
| 1            | On-time completion   | 30                 |                       |
| 2            | Quality of execution | 70                 |                       |
| Grand Total  |                      | 100                |                       |

Prepared by:

Checked by:

Name and Signature (Site Engineer)  
Position  
Procuring Agency

Name and Signature (Supervising Engineer)  
Position  
Procuring Agency

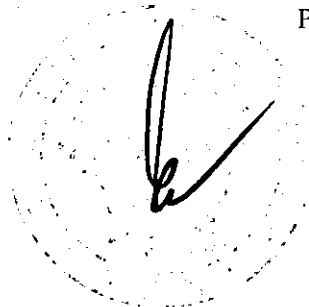

Guideline for Average Performance Score from previous work (100 points)

This parameter gives points to the contractor based on its performance for every project the contractor executes.

The 100% performance score will be composed of the following parameters:

1. *On-time completion (30%)*
2. *Quality of execution (70%)*

1. **On-time completion (30 points)**

Scoring for this component of performance will be done by the site engineer (that is, the implementing agency). A contractor can be penalized under this component if (s)he fails to deliver the project as per the initial time-lines committed.

The site engineer can penalize the contractor to an extent of 30 points. The quantum of penalty could vary as following:

- **10 points deducted for a minor default from 30 points**  
(if the final completion of the project is delayed by 10 - 15% as compared to original project duration)
- **20 points deducted for a medium default from 30 points**  
(if the final completion of the project is delayed by 15 - 25% as compared to original project duration)
- **30 points deducted for a major default from 30 points**  
(if the final completion of the project is delayed by 25% or more as compared to original project duration)

2. **Quality of execution (70 points)**

The scoring on this component of performance will be done by the Site Engineer based on the following guideline.

The scoring shall be conducted for each of the following types of construction:

1. Buildings (W3);
2. Roads (W1);
3. Bridges (W1);
4. Electrical/Telecommunication (W4);

For each of the above, following percentages shall be distributed:

- |                               |   |     |
|-------------------------------|---|-----|
| 1. Beginning of construction  | - | 35% |
| 2. During the construction    | - | 35% |
| 3. Completion of construction | - | 30% |



### 1. ELECTRICAL/TELECOMMUNICATION WORKS

| Sl. No.            | Construction Components                          | Scoring %  | Score Obtained |
|--------------------|--|------------|----------------|
| <b>I</b>           | <b>Beginning phase of Construction</b>           |            |                |
| a                  | Plant and Equipment                              | 5          |                |
| b                  | Key Technical Personnel                          | 10         |                |
| c                  | Documents (contract agreement, design, drawings) | 5          |                |
| d                  | Layout and Alignment                             | 15         |                |
| <b>Sub Total</b>   |  | <b>35</b>  |                |
| <b>II</b>          | <b>During Construction</b>                       |            |                |
| a                  | Use of specified materials                       | 10         |                |
| b                  | Quality of work executed                         | 15         |                |
| c                  | Work executed as per drawing                     | 10         |                |
| <b>Sub Total</b>   |  | <b>35</b>  |                |
| <b>III</b>         | <b>Completion phase of Construction</b>          |            |                |
| a                  | Finishes   | 10         |                |
| b                  | Material Brand                                   | 10         |                |
| c                  | Testing  | 10         |                |
| <b>Sub Total</b>   |  | <b>30</b>  |                |
| <b>Grand Total</b> |  | <b>100</b> |                |

Note: - The above obtained score is to be scaled down to 70.



# **SAMPLE BILL OF QUANTITIES**

A circular stamp containing a handwritten signature in black ink. The signature is stylized and appears to be a single name or set of initials. The stamp itself is faint and circular, with the signature centered within it.



**Bill of Materials for Construction of 33 kV line with DOG conductor and shield wire  
on Telescopic pole at Bondheyma, Mongar Dzongkhag**

Length of line in (km)

1.00

| SI #     | Particulars   | Unit | Total Quantity |
|----------|---|------|----------------|
| <b>A</b> | <b>Foreign Materials</b>  |      |                |
| 1        | 12 m long telescopic poles with base plate and pole cap.  | No   | 18             |
| 2        | Shielding arrangement on single pole with U-type connector and other accessories.                           | Set  | 8              |
| 3        | Single pole top cross-arm assembly complete with clamps, bracing, nuts & bolts and other accessories.       | Set  | 8              |
| 4        | Single pole lower cross-arm assembly complete with clamps, nuts, bolts and other accessories.               | Set  | 8              |
| 5        | Shielding arrangement on double pole with clamps, cross-arm channel, cross-arm strap and other accessories. | Set  | 5              |
| 6        | Top cross-arm assembly for H-frame complete with clamps, nuts, bolts and other accessories.                 | Set  | 5              |
| 7        | Cross brace arm assembly for H-frame with clamps, nuts, bolts and other accessories                         | Set  | 5              |
| 8        | Stay set assembly (one turn buckle, one V-hanger, one stay rod with base plate)                             | Set  | 10             |
| 9        | 33 kV Stay insulator  | No   | 10             |
| 10       | GI stay wire 7/8 SWG  | Mtr  | 130            |
| 11       | Stay clamp assembly   | Set  | 10             |
| 12       | Guy preform for 7/8 SWG wire  | Set  | 4              |
| 13       | 33 kV disc insulator assembly with hardware fittings  | Set  | 30             |
| 14       | 33 kV pin insulator complete with pin   | Set  | 39             |
| 15       | Preform dead end terminations - DOG   | No   | 30             |
| 16       | Tension/Compression joints for DOG Conductor.   | No   | 9              |
| 17       | Tension joints for Shield wire.   | No   | 3              |
| 18       | ACSR conductor - DOG  | km   | 3.1            |
| 19       | Shield wire-7/2.0   | km   | 1.1            |
| 20       | PG clamp for DOG  | No   | 30             |
| 21       | Spike earthing set  | Set  | 18             |
| 22       | Anticlimbing Device   | Set  | 18             |
| 23       | Danger plate (enamelled) 33 kV  | No   | 13             |
| 24       | 30 kV, 10 kA, lighting arrestor complete set (station type)   | Set  | 0              |
| 25       | Suspension clamp with hook bolt and nut for Shield Wire support on Single Pole Structure                    | No   | 7              |
| 26       | Strain/ Dead end clamp with hook bolt and nut for Shield Wire support on Double Pole Structure              | No   | 5              |

A handwritten signature is present in the bottom right corner, overlaid on a circular stamp that is mostly illegible.

**Bill of Materials for Construction of 33 kV line with DOG conductor and shield wire on  
Telescopic pole at Pemathang in Samdrup Jongkhar Dzongkhag**

Length of line in (km)

1.00

| Sl #     | Particulars   | Unit | Total Quantity |
|----------|---|------|----------------|
| <b>A</b> | <b>Foreign Materials</b>  |      |                |
| 1        | 12 m long telescopic poles with base plate and pole cap.  | No   | 18             |
| 2        | Shielding arrangement on single pole with U-type connector and other accessories.                           | Set  | 8              |
| 3        | Single pole top cross-arm assembly complete with clamps, bracing, nuts & bolts and other accessories.       | Set  | 8              |
| 4        | Single pole lower cross-arm assembly complete with clamps, nuts, bolts and other accessories.               | Set  | 8              |
| 5        | Shielding arrangement on double pole with clamps, cross-arm channel, cross-arm strap and other accessories. | Set  | 5              |
| 6        | Top cross-arm assembly for H-frame complete with clamps, nuts, bolts and other accessories.                 | Set  | 5              |
| 7        | Cross brace arm assembly for H-frame with clamps, nuts, bolts and other accessories                         | Set  | 5              |
| 8        | Stay set assembly (one turn buckle, one V-hanger, one stay rod with base plate)                             | Set  | 10             |
| 9        | 33 kV Stay insulator  | No   | 10             |
| 10       | GI stay wire 7/8 SWG  | Mtr  | 130            |
| 11       | Stay clamp assembly   | Set  | 10             |
| 12       | Guy preform for 7/8 SWG wire  | Set  | 4              |
| 13       | 33 kV disc insulator assembly with hardware fittings  | Set  | 30             |
| 14       | 33 kV pin insulator complete with pin   | Set  | 39             |
| 15       | Preform dead end terminations - DOG   | No   | 30             |
| 16       | Tension/Compression joints for DOG Conductor.   | No   | 9              |
| 17       | Tension joints for Shield wire.   | No   | 3              |
| 18       | ACSR conductor - DOG  | km   | 3.1            |
| 19       | Shield wire-7/2.0   | km   | 1.1            |
| 20       | PG clamp for DOG  | No   | 30             |
| 21       | Spike earthing set  | Set  | 18             |
| 22       | Anticlimbing Device   | Set  | 18             |
| 23       | Danger plate (enamelled) 33 kV  | No   | 13             |
| 24       | 30 kV, 10 kA, lighting arrestor complete set (station type)   | Set  | 0              |
| 25       | Suspension clamp with hook bolt and nut for Shield Wire support on Single Pole Structure                    | No   | 7              |
| 26       | Strain/ Dead end clamp with hook bolt and nut for Shield Wire support on Double Pole Structure              | No   | 5              |