

SECTION VI – TECHNICAL SPECIFICATIONS

CONTENTS

CHAPTER 5: CONSTRUCTION STANDARD	1
5.1 Overhead Lines	1
5.1.1 Choice of Route	1
5.1.2 Approval of Line Routes	1
5.1.3 Tree Clearances	2
5.2 Overhead Line Construction	3
5.2.1 Pit Marking and Digging Procedure	3
5.2.2 Erection of Supports	3
5.2.3 Erection of Double Pole Structures for Angle Locations	4
5.2.4 Special Foundation in Unstable Soil	4
5.2.5 Anchoring and Providing Guys for Supports	4
5.2.6 Fixing of Cross Arms and Insulators	5
5.2.7 Erection of ACSR Conductor	5
5.2.8 Mid-Span Jointing of Conductors.....	6
5.2.9 Jumpering	6
5.2.10 Sagging and Tensioning of Conductors	6
5.2.11 Conductor Sag and Tension	8
5.2.12 Supports at Different Elevation.....	11
5.2.13 Good Conductor Stringing Work Practices	12
5.2.14 HV ABC Accessories.....	13
5.2.15 Low Voltage Aerial Bundled Cable	14
5.3 Special Crossings	15
5.4 Guarding	15
5.5 Pole Earthing	16
5.6 Final Completion and Commissioning of MV Lines	16
5.7 Installation of Distribution Transformer.....	16
5.7.1 Pole Mounted Transformers.....	17
5.7.2 Site Selection for Pole mounted Transformers.....	17
5.7.3 Pad Mounted Distribution Transformers.....	17
5.8 Substation Earthing.....	18
5.9 Transportation and Handling of Transformers.	18

5.10	Protection of Distribution Transformers	19
5.11	General Requirement of Distribution Boards.....	21
5.12	Connection of supply to consumer’s premises	24
5.12.1	Consumer Metering.....	24
5.12.2	Direct Connected Metering.....	24
5.12.3	CT Metering	25
5.12.4	High Voltage Metering.....	25
5.13	Underground Cable Installation	25
5.13.1	General.....	25
5.13.2	Outdoor Cable Installation.....	26
5.13.3	Bending Radii for Cables	27
5.13.4	Terminations Clamping & Miscellaneous Details.....	27
5.13.5	Earthing of Cables	28
LIST OF DRAWINGS		29

CHAPTER 5: CONSTRUCTION STANDARD

5.1 Overhead Lines

5.1.1 Choice of Route

The route selected for an overhead line should be the one that will give the lowest cost over the life of the line. Route selection therefore involves consideration of a number of factors, including the cost of landowner compensation, the cost of transporting materials to the site, construction cost and the cost of ongoing maintenance requirements including vegetation control. As a general rule, line routes should be as short as practicable and should run as close to a road as possible since this facilitates access for both construction and maintenance. Consideration should also be given to the location of possible future line extensions, either to supply potential new loads or to service towns and villages that are currently unelectrified. Following parameters should be kept in mind:

- The shortest route practicable.
- As close as possible to the road for easy maintenance and approach during construction.
- Route in direction of possible future load.
- Angle points should be less.

Where possible, distribution line routes should avoid steep hills or valleys, swamps, lakes, thick forests, rivers or other locations where access is difficult or long spans are required. When building along a road, pole positions should not cause a traffic hazard or be in locations where there is a higher probability of vehicle impact.

The following should be avoided wherever possible:

- Areas likely to be used for future urban development;
- Routes incorporating sharp changes in line direction;
- Routes close to aerodromes;
- Religious monuments;
- Special trees of religious significance;
- School playgrounds;
- Cemeteries; and
- Buildings containing explosives.

Construction of lines over private land involves negotiation of a right of way and payment of compensation, and is to be avoided if a cost effective alternative route along public roads is available.

5.1.2 Approval of Line Routes

Prior to the erection of lines along public roads, the authority responsible for the road should be contacted and approval obtained for the location of all poles, road crossings, tree cutting or

trimming, and guying locations. Where overhead distribution lines are to be constructed in urban areas, it will also be necessary to contact the local Town Planning Authority for approval. Where appropriate, approval should also be obtained from authorities such as the National Environment Commission, Department of Forestry, etc.

Once the line route is finalized, a detailed line survey should be undertaken and the pole locations finalized and marked. Poles should be located well clear of water and other areas of potential land subsidence. Poles for lines that cross agricultural fields should, wherever possible, be located at bunds. Procedure for Obtaining Environmental Clearance for the new project from National Environment Commission Secretariat (NECS) is given below:

- Fill in the project details in environmental clearance application guidelines for power transmission and distribution lines.
- Attached the following relevant statutory Approvals:
 1. Public Clearance from the affected parties if the tower/poles falls in Private Registered land.
 2. Gewog Approval from the concerned Gewog
 3. Forestry Clearance
 4. Dzongkhag Approval
 5. GPS Data / the google earth map of the project.
 6. Site Visit report from the Dzongkhag Environment committee (DEC).
- Submit the duly filled environmental clearance application with the aforementioned attachments to NECS for Environmental Clearance for the project through EDCCD.

5.1.3 Tree Clearances

The width of line route to be cleared of trees will depend upon the voltage and the importance of the line concerned. While no rigid limits are provided, the following clearances should be adhered to, as far as possible.

Table 86: Tree Clearance Distances

Voltage	Comment
Low voltage ABC	Left to the discretion of the supervisor. Aerial bundled low voltage conductor is insulated so contact with vegetation should not cause a fault. However the route should be cleared so the risk of tress falling on the line is minimized.
11 kV lines (Bare Conductor)	The route should be cleared of all growth within 4.5 m of the centre line and, in addition, of trees that could fall and contact the line.
33 kV lines (Bare conductor)	The route should be cleared of all growth within 6 m of the centre line and in addition, of trees that could fall and contact the line.
AAAC Covered Conductor	The route should be cleared of all growth within 4.5 m of the centre line and, in addition, of trees that could fall and contact the line.

5.2 Overhead Line Construction

The construction of overhead lines may be divided as follows:

5.2.1 Pit Marking and Digging Procedure

After surveying, the pole location should be marked with peg. The pits should not be too large than necessary, as otherwise, after erection of the pole and filling there remains a possibility of tilting of pole. For Steel Tubular poles, the depth of the foundation shall be 1400 mm for 7.5 m pole and 1800 mm for 10 m pole, while the size of the foundation pit will be 600x800mm with longer axis in the direction of the line.

For Telescopic pole, the depth of the foundation shall be 1966 mm for 11.2 metre pole and 2100 mm for 12 m pole, while the size of the foundation pit shall be 800x1000 mm.

5.2.2 Erection of Supports

Steel poles that are not hot dip galvanized should be delivered to site with the exterior of the pole pre-painted with bituminous paint from the base of the pole up to ground level and rest with aluminum paint before the pole is installed.

Before the pole is put into the pit, pole cap and suitable base plate shall be fixed at the pole base to increase the surface contact between the pole and the soil. Once the pole is erected inside the pit, wooden deadmen may be utilized to facilitate lifting of the pole. Once lifted into the pit, the pole should be kept in a vertical position with the help of ropes, using them as a temporary anchor. It should be ensured that, at the time of erection, four men are at the ropes and the supervisor should be at a distance for guiding correct position so that in the event of breaking of rope, if pole falls, it will not result into an accident.

As the poles are being erected, say from an anchor point to the next angle point, the alignment of the poles is to be visually checked and set right. The verticality of the poles shall be checked with a spirit level in both transverse and longitudinal directions. In case of LV lines, the holes for fixing hook brackets should also to be checked to ensure they are facing the proper direction.

Once the verticality and alignment are satisfactory, the pit shall be backfilled and compacted to a distance of 450mm below ground level. A 450 x 450 mm (HT) & 350x350mm (LT) concrete foundation shall then be constructed around the pole and extending to 300 mm above the ground level as shown in the relevant drawings. The concrete shall be a mixture of cement, granite chips of 20/30 mm mesh and sand in the ratio of 1:2:4. The top of the foundation shall be tapered to allow water to run away from the pole.

Concrete foundations are not required for poles that are hot dip galvanised. In this case the foundation should be backfilled with excavated soil. The backfill should be progressively compacted as the foundation is filled. Do not simply refill the foundation and compact at the surface.

After the poles have been set and the excavated pit backfilled and compacted, the temporary anchors may be removed.

5.2.3 Erection of Double Pole Structures for Angle Locations

On medium voltage lines, where the angle of deviation is more than 10 degrees, a double pole structure shall generally be erected. The pits are to be excavated along the bisection of the angle of deviation. If the angle of deviation is more than 60 degree, a four pole structure is to be used as shown in drawing no. BPC-DDCS-2015-61.

After erection of the poles the pits will need to be temporarily backfilled so the poles can be climbed and the horizontal bracing fitted. The structure should then be set for verticality and alignment and the supports held in position with the help of temporary rope guys.

The temporary backfilling should be removed and permanent foundations constructed by backfilling, compacting and, if necessary, concreting each pit as described in section 5.2.2. Concrete foundations are not required if the poles are hot dipped galvanised.

Guys along the bisection of the angle of deviation, as required by the conductor size and angle of deviation, are to be provided. These shall be constructed in accordance with section 5.2.5.

5.2.4 Special Foundation in Unstable Soil

Special care has to be taken where foundation in unstable soil is encountered. In such locations, mass concrete foundations, extending the full length (below the ground) of the pole, are to be adopted to avoid collapse of foundation in the unstable soil. The concrete is to be a mixture of cement, granite chips of 20/30 mesh and sand in the ration of 1:2:4.

5.2.5 Anchoring and Providing Guys for Supports

One or more guys shall be provided for all supports where there is an unbalanced force on the support that may result in tilting/ uprooting or breaking of the support. Normally, these guys are provided at the following locations:

- Angles;
- Dead end locations;
- Tee-off points; and
- Steep gradient locations to avoid uplift on the poles.

Guy wires shall be angled at 45o from the vertical for 33 kV and 11 kV lines and 30o from the vertical for low voltage lines. Single guys shall be provided for single poles with line deviations from 5° to 10° and also for double poles with line deviations not exceeding 30°. Where the angle of deviation exceeds 30°, two guys along the resultant angle of line deviation or one guy in each direction of the line shall be provided. When two or more stays are fixed to the same support, each stay should be attached separately to the pole.

The installation of guy will involve the following works:

- Excavation of pit and fixing guy rod;

- Backfilling and compacting the guy foundation;
- Fastening guy wire to the support; and
- Tightening guy wire and fastening to the anchor.

After completion of installation work the foundation shall be allowed to consolidate for at least 7 days before installation of the guy wire. When installing the guy wire, the turnbuckle shall be mounted at the pole end of the stay and guy wire so fixed that the turn buckle is half way in the working position; thus giving the maximum movement for tightening or loosening. No guy insulator shall be located less than 3 m from the ground. While binding the stay, pole should not be tilted. Thimble is necessary for stay binding. Where sufficient space is not available, the arrangement such as bow guy and stud pole support as shown in drawing no. BPC-DDCS-2015 60 may be adopted.

5.2.6 Fixing of Cross Arms and Insulators

The practice of fixing the cross arm and top hamper before the pole erection is acceptable. If the cross arm is mounted after the support is erected, all the materials or tools required should be lifted or lowered by means of the hand line.

In such case, lineman should climb the pole with necessary tools. The cross arm is then tied to a hand line and pulled up by the ground man through a pulley till the cross arm reaches the line man. The ground man should station himself on one side, so that if any material drops from the top of the pole, it may not strike him. All the materials should be lifted or lowered through the hand line, and should not be dropped. Horizontal cross arms and pole top brackets shall be fitted as shown in the relevant drawings.

Line conductors are electrically insulated from each other as well as from pole by insulators. There are two types of porcelain insulators.

- The pin type insulators are generally used for straight stretch of line. The insulator and its pin should be mechanically strong enough to withstand the resultant force due to combined effect of wind pressure and weight of the conductor in the span.
- The strain insulators are used at terminal locations or dead end locations where the angle of deviation of the line is more than 10°.

In general the tie wire should be the same kind of wire as the line wire i.e. aluminium tie wire should be used with aluminium line conductor. The tie should always be made of soft annealed wire so that it may not be brittle and injure the line conductor. A tie wire should never be used for second time. The length of the wire will vary from 1m for 11 kV insulators to 3 m for 33 kV insulators.

5.2.7 Erection of ACSR Conductor

During running out, the conductor drum should be securely supported on drum jacks with an axle, so that the conductor is pulled from the top of the drum. The drum jacks should be on a firm foundation and the axle of the drum jack should be levelled horizontally. Care must be taken to ensure that the conductors are not damaged by contact with the ground or pole hardware during

running out and that kinking, twisting or abrading the conductor is avoided. The conductor should not be trampled on, run over by vehicles or dragged over the ground.

Extreme care must be taken to avoid contact with the conductors of any other live line in the vicinity when running out or stringing conductors, and if necessary neighbouring lines should be de-energised during the stringing operation. Stays shall be installed and kept in position before conductors are strung to avoid over straining of poles. Stringing pulleys shall be used while stringing conductors.

5.2.8 Mid-Span Jointing of Conductors

Mid-span jointing of conductors shall use compression joints correctly sized for the conductor and made with a proprietary compression tool using correctly sized dies. Before jointing, the conductor ends should be properly cleaned. In case of copper, clean by sand paper and for aluminium conductor, first apply jointing compound and then brush so as to remove the aluminium oxide. Mid span joints shall be avoided in the long spans such as river crossing, valley, etc.

5.2.9 Jumpering

The jumper should always be connected through P.G. clamps. Care should be taken that mid span joint will not be less than 40 ft. from pole. Every joint should be done carefully. Where conductor strands are cut, repair sleeve is used. Conductor joint strength should be 95 % that of conductor, and resistance should be that of main conductor.

5.2.10 Sagging and Tensioning of Conductors

After completion of conductor stringing and making any mid-span joints, conductor tensioning operations can commence. The conductors are first attached to the insulator string assembly at the non-tensioning end of the section, using preformed dead-ends. Further, before tensioning commences, temporary guys should be provided as necessary for the anchoring supports at each end of the line section to be tensioned to avoid over-stressing the strain poles due to unbalanced loads.

The centre conductor should be tensioned first followed by the outer two conductors. At the tensioning end, the conductor being tensioned is pulled manually up to a certain point and then a come-along clamp is fixed to it. The grip to the come-along clamp is attached to a double sheave pulley block or a pull-tight machine and the conductor is gradually tensioned.

The conductor should then be sagged in accordance with the sag-temperature chart for the particular conductor and span. The correct sag should be measured in the middle span of the section.

The stretch of the conductor has to be taken out before sagging in order to avoid the gradual increase in sag, due to the setting down of the individual wires. There are two ways of accomplishing this:

- **Prestressing**

Using the prestressing method, the conductor is pulled unto a tension considerably above the correct figure, but never exceeding 50% of breaking load for a period of about twenty minutes. As this method requires more time and involves the use of stronger tackle to secure the higher tension, it is not commonly used.

- **Overtensioning**

The overtensioning method consists of pulling up the conductor to a tension of 5%-8% above the theoretical tension for the prevailing temperature and fixing the conductor at that tension with correspondingly reduced sag. Over time, the conductor will settle down to the correct sag and tension.

Conductors can be sagged correctly only when the tension is the same in each span throughout the entire length of the section. Use of snatch blocks during sagging reduces the friction and chances of inequality of tension in various spans.

Measurement of conductor sag can be accomplished by several different methods but most commonly used method is 'sighting'. Targets are placed on the supports below the cross arms. The targets may be light strips of wood, which are clamped to the pole at each end of the sagging span at a distance below the conductor when the conductor is placed in snatch blocks that is equal to the required sag. A lineman sights the sag from the next pole and the tension of the conductor is reduced or increased, until the lowest part of the conductor in the span coincides with the lineman's line of sight.

When sagging is completed, the preformed dead end should be fixed to the tension end. The dead-end and socket thimble can be fitted to the conductor without releasing the tension. A mark is made on the conductor at a distance from the cross arms equal to the length of the complete strain insulator to indicate where the dead-end should be installed.

After the dead-end has been installed and the insulator string attached to the top hamper or crossarm, the conductor is pulled in sufficiently using the come-along clamp, to allow the insulator assembly to be fitted to the socket thimble. After the conductor is attached, the conductor tension may be released gradually. If the tension is released with a jerk, an abnormal stress may be transferred to conductor and support, which may result in the failure of the cross arms, stay or pole.

After the stringing is completed, all poles, cross-arms, insulators, fittings, etc. should be checked to ensure that there have been no deformities, etc.

The conductor is then placed on the pin insulator on each pole ready for tying and to remove the snatch blocks. On straight line poles the conductor should be tied to the top groove of the insulator and on angle poles the conductor should be tied to the side groove. The conductor is then fastened to the insulator using aluminium helities or binding wire conforming to IS 12048.

In fastening the conductor to pin insulators, the following points should be observed:

- The correct size of binding wire, which can be readily handled, and with adequate strength should be used.

- The length of tie wire should be sufficiently long for making the complete tie including and end allowance for gripping each end.
- A good tie should provide a secure binding between the line conductor and insulator, and should reinforce the conductor on either side of the insulator.
- The use of cutting pliers for binding the tie wire should be avoided.
- A helitie or binding wire that has been used previously should not be reused.
- Before tying the conductor to the insulator, it shall be ensured that only the portion of helities wrapped with chloroprene pad (where applicable) touches the insulator.

At section poles correctly sized parallel groove (PG) clamps must be used to connect the two conductor tails.

5.2.11 Conductor Sag and Tension

The following sag-span tables are provided for the guidance of field staff when stringing conductors.

Table 87: Sag-Span Chart – 33 kV, WOLF

Conductor : WOLF
Voltage : 33 kV
Design Tension : 3.42 kN at 15°C, no wind (approx 5% MBL)

Temp	10°C	15°C	25°C	30°C	75°C
Span (m)	Sag (m)				
40	0.37	0.42	0.51	0.55	0.70
50	0.60	0.65	0.75	0.80	0.97
60	0.88	0.94	1.04	1.09	1.28
80	1.61	1.67	1.78	1.84	2.04
100	2.55	2.62	2.73	2.79	3.27
150	5.82	6	6	6.07	6.60

Table 88: Sag-Span Chart – 33 kV, DOG

Conductor : DOG
Voltage : 33 kV
Design Tension : 1.95 kN kg at 15°C, no wind (approx 5% of MBL)

Temp	10°C	15°C	25°C	30°C	75°C
Span (m)	Sag (m)				
40	0.34	0.40	0.50	0.55	0.88
50	0.56	0.62	0.73	0.79	1.17
60	0.83	0.89	1.01	1.07	1.49

80	1.52	1.59	1.72	1.78	2.26
100	2.38	2.45	2.59	2.65	3.19
150	5.44	5.52	5.66	5.73	6.33

Table 89: Sag-Span Chart – 33 kV, RABBIT

Conductor : RABBIT
Voltage : 33 kV
Design Tension : 1.04 kN kg at 15°C, no wind (approx 5% of MBL)

Temp	10°C	15°C	25°C	30°C	50°C
Span (m)	Sag (m)				
25	0.125	0.157	0.231	0.266	0.389
30	0.187	0.227	0.310	0.350	0.488
35	0.262	0.308	0.400	0.443	0.595
40	0.352	0.403	0.501	0.547	0.712
60	0.845	0.907	1.023	1.078	1.280

Table 90: Sag-Span Chart –33 kV, AAAC Covered (111.3sq.mm)

Conductor : AAAC Covered (111.3sq.mm)
Voltage : 33 kV
Design Tension : 1.22 kN at 15°C, no wind (approx 5% MBL)

Temp	10°C	15°C	25°C	30°C	75°C
Span (m)	Sag (m)				
40	1.27	1.29	1.35	1.37	1.58
50	1.99	2.02	2.07	2.10	2.32
60	2.88	2.91	2.96	2.99	3.21
70	3.93	3.96	4.01	4.04	4.27
80	5.15	5.17	5.23	5.25	5.48
90	6.52	6.55	6.6	6.63	6.86

Table 91: Sag-Span Chart – 11 kV, DOG

Conductor : DOG
Voltage : 11 kV
Design Tension : 5.71 kN kg at 15°C, no wind (approx 17% of MBL)

Temp	10°C	15°C	25°C	30°C	75°C
Span (m)	Sag (m)				
40	0.12	0.14	0.18	0.22	0.65
50	0.19	0.21	0.28	0.33	0.84
65	0.27	0.31	0.40	0.45	1.03
80	0.49	0.54	0.68	0.75	1.46
100	0.76	0.84	1.01	1.11	1.93
150	1.76	1.88	2.14	2.26	3.33
200	3.20	3.35	3.65	3.80	5.05
250	5.06	5.23	5.57	5.74	7.13

Temp	10°C	15°C	25°C	30°C	75°C
Span (m)	Sag (m)				
300	7.35	7.54	7.90	8.07	9.57

Table 92: Sag-Span Chart – 11 kV, RABBIT

Conductor : Bare ACSR RABBIT
Voltage : 11 kV
Design Tension : 3.02 kN kg at 15°C, no wind (approx 17% of MBL)

Temp	10°C	15°C	25°C	30°C	50°C
Span (m)	Sag (m)				
25	0.047	0.054	0.076	0.093	0.220
30	0.068	0.078	0.108	0.131	0.280
35	0.093	0.106	0.146	0.174	0.344
40	0.122	0.139	0.188	0.222	0.412
60	0.278	0.313	0.404	0.460	0.720

Table 93: Sag-Span Chart –11 kV, AAAC Covered (111.3sq.mm)

Conductor : AAAC Covered (111.3sq.mm)
Voltage : 11 kV
Design Tension : 4.13 kN at 15°C, no wind (approx 17% of MBL)

Temp	10°C	15°C	25°C	30°C	50°C
Span (m)	Sag (m)				
40	0.29	0.38	0.52	0.58	0.98
50	0.50	0.59	0.75	0.81	1.27
60	0.77	0.86	1.02	1.09	1.60
70	1.07	1.16	1.33	1.40	1.96
80	1.43	1.52	1.69	1.77	2.36
90	1.84	1.93	2.10	2.18	2.80
100	2.29	2.38	2.55	2.63	3.28
150	5.26	5.35	5.23	5.61	6.34

Table 94: Sag-Span Chart –11 kV, AAAC Covered (49.98sq.mm)

Conductor : AAAC Covered (49.98sq.mm)
Voltage : 11 kV
Design Tension : 2.01 kN at 15°C, no wind (approx 17% of MBL)

Temp	10°C	15°C	25°C	30°C	50°C
Span (m)	Sag (m)				
40	0.31	0.40	0.53	0.59	0.98
50	0.53	0.62	0.77	0.83	1.28
60	0.80	0.89	1.04	1.11	1.62
70	1.12	1.21	1.37	1.44	1.99
80	1.50	1.58	1.74	1.82	2.40
90	1.92	2.00	2.17	2.24	2.85

100	2.39	2.47	2.64	2.72	3.35
150	5.48	5.56	5.73	5.82	6.52

Table 95: Sag-Span Chart – HV ABC (95sq.mm)

Conductor : HV ABC (95sq.mm)
Voltage : 11 kV
Design Tension : 3.72 kN at 15°C, no wind (approx 5% of MBL)

Temp	10°C	15°C	25°C	30°C	50°C
Span (m)	Sag (m)				
20	0.53	0.54	0.55	0.56	0.54
30	1.21	1.21	1.23	1.24	1.21
40	2.15	2.16	2.17	2.18	2.16
50	3.33	3.37	3.46	3.50	3.37
60	4.84	4.85	4.87	4.88	4.85
70	6.60	6.60	6.62	6.63	6.60

Table 96: Sag-Span Chart – HV ABC (50sq.mm)

Conductor : HV ABC (50sq.mm)
Voltage : 11 kV
Design Tension : 2.01 kN at 15°C, no wind (approx 17% of MBL)

Temp	10°C	15°C	25°C	30°C	50°C
Span (m)	Sag (m)				
40	0.31	0.40	0.53	0.59	0.74
50	0.53	0.62	0.77	0.83	1.00
60	0.80	0.89	1.04	1.11	1.30
70	1.12	1.21	1.37	1.44	1.65
80	1.50	1.58	1.74	1.82	2.03
90	1.92	2.00	2.17	2.24	2.46
100	2.39	2.47	2.64	2.72	2.94
150	5.48	5.56	5.73	5.82	6.06

5.2.12 Supports at Different Elevation

Where the supports at each end of a span are at different elevations the following formula can be used for sagging the conductor.

$$d_1 = d(1-h/4d)^2$$

where:

d_1 = vertical distance between the conductor at the lower support and the lowest mid-span point.

d = sag for a level span equal to the slope distance between the poles. The slope distance is the distance that would be measured by a tape stretched between the two poles. Once this is

known the value of d can be taken from table 78 to table 88 above.

h = difference in height between the conductor at each end of the span.

The above formula can be used to determine the value of d_1 . A sighting board can then be attached to the lower support pole and the conductor sagged be sighting horizontally through it. One way to do this would be to attach a second sighting board to the next pole. Check that the two sighting boards are level using a taut line and spirit level. The sag can then be sighted using the two sighting boards.

5.2.13 Good Conductor Stringing Work Practices

DO:

- Use proper equipment for handling aluminium conductors at all times.
- Use skids, or similar method for lowering reels or coils from transport to ground.
- Examine the reel before unreeling for presence of nails or any other object, which might damage the conductor.
- Rotate the reel or coil while unwinding the conductor.
- Unwind the conductor in the direction of the arrow on the side of the drum
- Grip all strands when pulling out the conductor.
- Control the unreeling speed with a suitable braking arrangement.
- Use wooden guards of suitable type to protect the conductor when pulling it over barbed wire fences, sharp rock edges or similar obstructions.
- Use long straight, parallel jaw grips with suitable liners when pulling the conductor in order to avoid nicking or kicking of the conductors.
- Use free-running sheaves or blocks with adequate grooves for drawing/paying conductors.
- Measure temperatures accurately with an accurate thermometer.
- Use proper sag charts.
- Mark conductors with crayons or adhesive tape or such other material which will not damage the strand.
- Make all splicing with the proper tools.

DO NOT

- Do not handle conductors without proper tools at any stage.
- Do not pull conductors without first ensuring that there are no obstructions on the ground.
- Do not pull out a greater quantity of conductor than is required.
- Do not make jumper connections on dirty or weathered conductor. Instead, clean the conductor with sandpaper. Alternatively apply a chromite or graphite conducting oxideinhibiting grease to the point of connection and then clean the conductor with a wire brush.

- Do not handle aluminium conductor in a rough fashion but handle it with care it deserves.

At road crossings, a flagman should be in attendance to that traffic is not unduly interrupted. The running of conductor across roads should only be carried out in with the approval of the Authority responsible for the road.

Conductor drums should be transported to the tension point without injuring the conductor. If, it is necessary to roll the drum on the ground for a small distance, it should be slowly rolled in the direction of the arrow marked on the drum.

When running out conductor the drum should be so supported that it can be rotated freely. For this purpose, the drum should either be mounted on the cable drum supports or jacks or hung by means of chain pulley of suitable capacity, suspended from a tripod. If it is not possible to raise the conductor drum by any of the above methods, a trench of suitable depth slightly bigger than the conductor drum may be dug, so as to facilitate free rotation of the drum when it is suspended above the trench using a steel shaft. While running out the conductor, care should be taken to ensure that the conductor does not rub against any metallic fitting of the pole or on the uneven or rocky ground. Wooden trusses may be used for this purpose to support the conductor when running out.

Should the length the conductor be less than the length of the section, the conductors should be run out from both ends and joined where they meet with a mid-span full tension joint.

On no account, should any part of the conductor shall be left overnight at a height of less than 5 metres above the ground. The work should be so arranged that before the end of the day, the conductor is raised to a minimum height of 5 metres above the ground by rough sagging.

5.2.14 HV ABC Accessories

The following accessories are required for the installation of the HV aerial bundled cables:

- Pole bracket assembly
- Suspension assembly
- Strain clamp/dead end assembly.
- GI support hook
- Bundled restraint assembly

Each assembly shall be complete with all necessary devices suitable for attachment to round steel poles by stainless steel strap. All metal fitting shall be of good quality galvanized mild steel or cast aluminum alloy. Each of the suspension/angle/dead end assemblies shall be supplied with a 1.75m of stainless steel strap with two buckles. Bundled end protection shall be provided for protecting cable dead ends and shall comprise a set of heat shrinkable polymeric terminal caps for fitting on each conductor, together with protective black PVC sleeve of 500mm length. The following connectors are required for the connection of HV aerial bundled conductors:

- (a) Insulated tension jointing sleeve
- (b) XLPE cable termination push on type

The connections shall be insulated and suitable for use on live lines. The teeth of the contact plates shall penetrate the bundled conductor insulation to establish contact with ABC cable without the need to strip the bundled conductor insulation. The connector shall be suitable for copper or aluminum tee-off conductor. Insulated tension jointing sleeves shall be provided for the bundled conductors. These shall be of the compression type, but compression shall not damage or displace the sleeve insulation. The sleeve connectors shall be designed to have the full rated breaking strength of the aluminium or aluminium alloy cable on which they are fitted.

5.2.15 Low Voltage Aerial Bundled Cable

A sag-span chart for ABC conductor, assuming typical installation conditions is given in table below.

Table 97: Sag-Span Chart for Low Voltage ABC

Conductor Size	50mm ²		95mm ²	
	2.52	5.04	4.79	9.58
Design Tension at 15 ^o C (kN)				
Span (m)	Sag (m)			
30	0.15			
40	0.26			
50	0.41			
60	0.59			
70	0.80			
80	1.04			
90	1.32			
100	1.63			
110	1.97			
120	2.35			
130	2.75			

BPC uses 7.5 m poles to support ABC conductors, and the maximum allowable span length on level ground is shown in table 90 below. The table assumes the cable is located 150 mm from the top of the pole, depth of burial is 1/6 of pole length and that minimum ground clearances are as shown in table 98.

Table 98: Maximum Spans for Aerial Bundled Cable

Pole Length (m)	Maximum Span (m)	
	Across Street	Elsewhere
7.5	50	80 (4 core)
		100 (2 core)

In installing aerial bundled cable the cable must be pulled from the top of the drum and should not be dragged along the ground. A suitable ‘drum brake’ mechanism should be used to prevent conductor overrun. Stringing pulleys compatible with bundled conductor shall be installed on every pole. During running out, the cable should be pulled out by hand or by using a nylon pulling grip designed for bundled cables. Insulated conductor grips designed to prevent damage to the

insulation of the conductor shall be used for tensioning. Every care must be taken to avoid damage to the conductor insulation.

Dead-end (termination) fittings shall be fitted to the conductor after tensioning at each termination point. Intermediate fittings shall then be fitted at major angles and then at smaller angles. After all fittings are in place the sagging should be checked at two places and corrected if necessary. Insulation straps (cable ties) shall be used to tie the conductor at each supporting point.

5.3 Special Crossings

In case the lines cross-over the other lines or buildings, safe minimum clearance are to be maintained as mentioned in table 9. The other crossings could also include for:

- Telephone lines
- Lines of other voltages
- Roads, streets and rivers.

Double pole or 3 pole or 4 pole structure would be required to be specially designed, depending upon the span and conductor size for the river crossing. The foundation of the structures should be sound so that it may not get eroded or damaged due to rain water. 12 m steel tubular pole shall be used in such situation.

5.4 Guarding

Guarding is an arrangement provided for the lines by which live conductor, when accidentally broken is prevented to come in contact with other electric lines, telephone lines, roads and persons or animals and carriages moving along the road, by providing a sort of cradle below the main electric line. The guarding is always earthed. In absence of guarding, conductor will fall on ground and as no protection is operated, conductor will remain charged. This will cause accidents. Hence the guarding is very essential.

Cradle guarding is adopted for lines with bare conductor at road crossing based on the risk imposed to pedestrian and vehicle plying below. Guarding shall be of 3 wire system. 1 wire on lower side and two on the upper side of the angle as shown in BPC-DDCS-2015-62. Requirement of guarding shall be as follows:

- Guarding is to be used for road crossing of power line with bare conductor only.
- G.I. wire of 8 W.S.G is used for guarding.
- The first lacing should be at a distance of 750 mm from the pole. Other lacing is tied at a distance of 3 meter from each other.
- The vertical distance between conductor and guarding in mid span should be 1220 mm.
- The clearance between line and guarding cross arm for 11 kV and 33 kV line should be 650 mm and 840 mm respectively.

5.5 Pole Earthing

All 11 kV and 33 kV steel poles should be separately earthed. The earth pin is a 2.5 m galvanized steel rod, which must be driven into undisturbed ground clear of the pit excavation. It is not acceptable to insert the earth rod in the pit excavation as the backfill used often does not provide a good earth connection.

The earth pin is connected to the pole using galvanized iron flat of size 25x6mm. The flat is connected from the pole base to the spike rod using nuts and bolts. Details of spike earthing are shown in drawing no. BPC-DDCS-2015-48.

The earth resistance of the pole and earth pin connected together should be as low as possible and ideally should not exceed 10 ohms. Additional earth pins, spaced at least 1 metre apart, should be used in difficult locations, to reduce the resistance. Stake earthing is not required for LV poles since the lines are of covered conductor.

The earthing stake for pole earths is also used for earthing LV distribution pillars.

5.6 Final Completion and Commissioning of MV Lines

Before a line is energised for the first time pre-commissioning installation work must be completed on each pole. This comprises:

- The painting of non-galvanised poles with aluminium paint with the bottom two metres above the ground and below the ground to be painted black;
- The attachment of anti-climbing device at a height of 3.5m to 4m from ground level to medium voltage pole to avoid unauthorized pole climbing. Fixing of danger notices to single/ double pole structure where required by BPC. The danger notices should be fixed about 2 metre above ground level and, where appropriate, should face the road or any track or other pedestrian walkway.
- Before commissioning a line into service, the line shall be visually checked over its full length to ensure that all structures are correctly installed, all pole earths are installed and connected, all conductors are correctly bound and terminated on all structures and all tools and other equipment have been removed.

The line shall be energised with all distribution substations isolated and unloaded on the low voltage side. Where the line is directly connected to a zone substation supply bus, rather than to an upstream line, the protective relay settings should be reduced. Once the line has been successfully energised, the correct protection relay settings should be applied and the distribution substations connected to the load one at a time.

5.7 Installation of Distribution Transformer

As discussed in previous section, transformer capacity of 125 kVA and below shall be pole mounted.

5.7.1 Pole Mounted Transformers

For installing pole-mounted transformers, as far as possible, subsidiary poles and street lighting poles should not be used as transformer poles. Special care should be taken to maintain proper climbing space and to avoid crowding of wire and equipments. Transformers should be installed only on poles strong enough to carry their weight. Transformer poles should be straight and, where necessary, guyed to prevent leaning or raking of the pole after the transformer is hung. Double cross-arms should be provided for each transformer installation. The climbing space (2400mm Pole Center-Center) should be carefully maintained so that it should not be necessary for a lineman to come close to the transformer tank in climbing up or down a pole. An anticlimbing device should be provided.

5.7.2 Site Selection for Pole mounted Transformers

The location of pole mounted distribution transformer substations should ideally be:

- As close as possible to the centre of the load, in order to reduce the voltage drop in the low voltage circuits;
- In a location that is clear of obstructions and is that provides satisfactory access for the incoming medium voltage overhead distribution line;
- Readily accessible for transport of the distribution transformer to site;
- Above a road rather than below it where this is practical; and
- In a location likely to provide a low resistance to earth.

5.7.3 Pad Mounted Distribution Transformers

Since the transformers operate without moving parts, generally a simple foundation is satisfactory; provided it is firm, horizontal and dry. The transformer should not rock or bed down unevenly so as to tilt, as this may strain the connections. The base should be horizontal to keep the oil level correct. For outdoor transformers where rollers are not fitted, leveled concrete plinth with bearing plates of sufficient size and strength can be adopted. The plinth shall be above the maximum flood level of the site and of the correct size to accommodate the transformer in such a way so that no person may step on the plinth. Where rollers are fitted, suitable rails or tracks should be provided and when the transformer is in the final position, the wheels should be locked by locks or other means to prevent accidental movement of the transformer.

The foundation should be constructed of Plain concrete cement or reinforced, air entrained concrete having enough strength to hold the individual transformer load. The dimension of the plinth shall be designed based on approved transformer drawing however the height of the plinth shall be 1000 mm above the ground level. The equipment installed shall be enclosed by a chain link fence. The size of chain link fence shall be 10 mx10 m as shown in drawing no. BPCDDCS-2015-63.

5.8 Substation Earthing

Particular care should be given to the construction of the earthing system as proper earthing of distribution transformer substations is necessary to ensure safe operation of the supply system. The earth pits should be located as shown in drawing no. BPC-DDCS-2015-64 and the earth connections to the substation structure are shown in drawing BPC-DDCS-2015-65.

BPC's standard earthing conductor for transformer substations is 25x6mm galvanised iron strap. Three electrodes are used forming an equilateral triangle with minimum distance of 6500 mm, so that adequate earth buffer is available. Each Electrode shall be a GI pipe of 4mm thick, 40mm outer dia and 2500mm long and buried vertically so as to leave about 4 inch pipe length above ground level to fix a 250x250mm G.I plate. The three earth electrodes should be connected together by an equipotential earthing ring embedded at least 100 mm below ground level. These are connected as follows:

- One earth electrode is connected to each lightning arrestor and the transformer tank. It is important that the earthing conductor is kept as short as possible.
- The second earth electrode is connected to the transformer LV neutral bushing, the transformer tank and the crossarms supporting the drop-out fuses.
- The third earth electrode is also connected to the transformer tank and LV neutral and also to the earth in the low voltage distribution cabinet.

There shall be minimum joints preferably no joints enroute to earth electrodes. Where Joints are unavoidable, they shall be brazed, riveted or welded and bolted (and painted with red lead and aluminum paints one after the other and finely coated with bitumen). The maximum permissible earth resistance as per the international standard is 5 ohms, however, due to difficulties to obtaining required value of 5 ohms, 25 ohms is allowable value in BPC. Modern earthing compounds are recommended instead of salt and charcoal to reduce the earth resistance of the substation in extreme situations.

5.9 Transportation and Handling of Transformers.

Distribution transformers should be stored in such a way that 'first in and first out' becomes a normal procedure. Care must be taken to place the transformers in store in such a fashion that no damage occurs to tank, bushings, etc. due to movement of personnel and materials.

Transformers should be loaded and unloaded with care. Prior to loading a transformer for dispatch to site, the transformer condition (bushings, fittings, tank, oil level, etc.) should be checked. If any damage is noticed, the in-charge should be notified immediately, and transformer should be loaded only after the written approval of the person in charge.

Every transformer dispatched to site should be entered individually in store register. This register should have the following:

- (i) Sl. No.
- (ii) Date of receipt
- (iii) Transformer capacity (kVA)

- (iv) Manufacturer's name
- (v) Date of Despatch to site
- (vi) Name of site

Transformers should be lifted using the lifting lugs provided on the transformer tank and the lifting arrangement should not cause unbalance of the transformer. Before lifting the complete transformer, it should be ensured that all cover bolts are tightened. The slings, lifting tackle, etc. to be used in hoisting of transformers should have adequate strength to handle the weight.

During transport of transformers, they should be rigidly secured to the transport vehicle and packing material put on either side of the base of the transformer to prevent skidding. A responsible official shall supervise the loading. Rollers, if provided, should be removed.

Care should be taken in transporting transformers to site to prevent the transformers moving when going up and down hills and around corners.

The transformer should be brought just adjacent to the double pole structure for hoisting it on the transformer platform. Lifting tackle should be used for hoisting transformer on the structure.

In case, it is not possible to bring the vehicle carrying transformer near the double pole structure, it should be unloaded at a nearest safe place and carried to the double pole structure manually with great care and under proper supervision or shifted on platforms fitted with rollers.

While hoisting transformers on the transformer platform, safety precautions by way of fixing additional clamps and bolts should be taken. Readymade slings to suit the capacity of transformer should be available.

5.10 Protection of Distribution Transformers

The pole mounted distribution substation arrangement has been standardized to the extent possible with the structure and the high voltage connections being identical for all transformer sizes. Dropout fuses are provided on H.V side of the transformer for isolating and protection. The size of fuse link used in these drop out fuses will vary with transformer rating. Acceptable fuse link sizes for BPC's existing transformer capacities are given in table 99 below: For transformers located at the remote end of rural feeders, where the short circuit levels are potentially low, fuse links at the lower end of the allowable range should be used.

Table 99: Acceptable Transformer Medium Voltage Fuse Link Ratings

MV Rating (kV)	Phases	Capacity (kVA)	Rated Current (A)	Fuse Link (A)
33	3	63	1.1	2 to 4
33	3	125	2.2	4 to 7
33	3	250	4.4	9 to 16
33	3	500	8.7	16 to 32
33	1	10	0.3	1 to 2
33	1	16	0.5	1 to 2
33	1	25	0.8	2 to 3

MV Rating (kV)	Phases	Capacity (kVA)	Rated Current (A)	Fuse Link (A)
11	3	16	0.8	2 to 3
11	3	24	1.3	2 to 4
11	3	63	3.3	7 to 9
11	3	125	6.6	16 to 25
11	3	250	13.1	32 to 40
11	3	500	26.2	50 to 100
11	3	1250	65.6	150 to 300
11	1	10	0.9	2 to 3
11	1	16	1.5	3 to 7

On the low voltage side of the transformer the supply cable is run into a 4-way feeder cubicle mounted on the transformer structure. The cubicle's incoming cable is terminated into a circuit breaker which can be used to offload the transformer. Three pole moulded case circuit breakers (MCCBs) shall be used for transformer sizes up to and including 315 kVA. Air circuit breakers may be used for larger transformers.

Circuit breakers shall comply with the requirements of IEC 60947-2 and shall be of the air break, quick make, quick break, trip free type, and fitted with electronic overcurrent, earth fault and short circuit protection. This protection shall not require an external power supply. The elements shall be adjustable so that adjustments are made simultaneously on all poles from a common adjustment control. The minimum interrupting current shall be 10 kA for transformers rated up to 250 kVA and 25 kA for larger transformers. When commissioning the transformer the MCCB overload shall be adjusted to be consistent with the full load transformer current as shown in table 99.

The size of the LV cable between the transformer and the feeder cubicle will depend on the size of the transformer, and is given in the following table 100. For non-standard intermediate size transformers the cable rating for the next size should be used. The table assumes that all cables up to 400 mm² are PVC insulated. The 630 mm² cable used on the 1,250 kVA transformer must be XLPE insulated in order to have the required rating.

Table 100: Low voltage cable ratings used between transformer and DP

Phases	Transformer Rating (kVA)	Maximum LV Current (A)	LV Cable Size (mm ²)
3	10	14	35
3	16	22	35
3	25	35	35
3	63	88	70
3	125	174	150
3	250	348	300
3	500	696	2x300
3	1250	1740	2x630 ¹
1	10	42	35
1	16	67	35
1	25	104	35

Note 1 Must be single core XLPE insulated cable.

MCCBs may be used to protect outgoing distribution circuits in urban areas. As for incoming circuit breakers, the minimum interrupting current shall be 10 kA for transformers rated up to 250 kVA and 25 kA for larger transformers. Whereas the incoming MCCB is set in accordance with the transformer size, the setting of the outgoing MCCBs should be determined by the size of the cable being protected. The maximum MCCB setting if used for outgoing circuits is given in table 101. In order to obtain protection discrimination, outgoing MCCB current settings should be lower than the incomer, even if this is less than the rating of the outgoing cable.

Table 101: Max. MCCB Ratings for Three Phase Low Voltage Aluminium Cable Circuits

Cable Size (mm ²)	Maximum MCCB current setting ¹
35	100
70	135
150	210
300	305
400	335

Note 1: This is the same as the cable rating given in table 100.

For low rating distribution substations the outgoing low voltage circuits will be ABC. These circuits shall be protected by fuses rather than MCCBs. Fuses shall be high rupturing capacity fuses with cartridge type links manufactured in accordance with IEC 60269-1. The fuse link rating shall be in accordance with table 102 below.

Table 102: Maximum Fuse Link Sizes for ABC Cable

Cable Size (mm ²)	Maximum Fuse Link Size (A)
50mm ² ABC	160
95 mm ² ABC	250

5.11 General Requirement of Distribution Boards

Distribution boards are used to connect customer service cables to distribution cables in underground or overhead systems. The pillar shall be sheet steel, robust, dust, weather and vermin proof, providing a degree of protection of IP 52 for indoor use and IP 54 for outdoor use. Sheet steel used shall be cold rolled, of minimum thickness 2.5 mm, smooth finished and appropriately stiffened to provide adequate strength. There shall be a removable gland plate of minimum 3 mm thickness. The distribution board shall have hinged doors with pad locking facility. Doors and other covers shall be fitted with neoprene gaskets, to satisfy the IP 52 and IP 54 requirements, to prevent ingress of dust, moisture and vermin.

All live parts shall have a minimum phase to phase and phase to earth clearance in air of 25 mm and 20 mm respectively. The removable cable gland plate of 2.5 mm cold rolled sheet steel is included. The interior cabling space is to be as per drawings. Requirements include an external earthing terminal suitable for 19 mm x 6 mm aluminium alloy earthing strip. Provide one number of HRC fuse puller for every distribution board.

The distribution board shall be provided with individual labels with designation or rating. The danger plate, as shown in the drawing, shall be fixed to every pillar door. All labels and plates shall be of corrosion resistant material. Distribution board can be categorized into three types as given in section 4.16.

Pole mounted transformers rated 125 kVA and below shall have the distribution board fixed on the pole or mounting platform. The board shall be supplied complete with a hot dipped galvanised steel fixing assembly, to allow the board to be mounted on one transformer station steel pole, at a height approximately 1200 mm above ground level. Fixing assembly is to fix to poles of diameters ranging from 120 to 300mm. large size distribution boards shall be plinth mounted near the substation. The components of transformer distribution boards are:

- **MCCBs and HRC Fuse**

MCCBs shall be heavy duty type, mounted on bases, having a rupturing capacity of 10kA for transformers rated at 250kVA and 25kA for larger transformers. Outgoing feeders shall be protected by HRC Cartridge Fuse of appropriate capacity of the distribution pillar. The minimum rated breaking capacity of outgoing HRC fuse shall not be below 50kA.

- **Main Busbars**

Main busbars shall be of aluminium of appropriate size. Busbars shall be horizontal, but with gradual gradient from front to rear as indicated in the drawing for the different phases. All busbars shall be solid, without joints and shall be rated for continuous maximum current. The maximum temperature of the busbars, under operating conditions when carrying rated normal current, shall not exceed 85°C. Busbars shall be adequately supported on insulators to withstand dynamic stresses due to short circuit current. Busbar support insulators shall conform to the relevant applicable Standard. Busbars shall not be painted and all performance characteristics specified shall be obtained with unpainted. The main busbar terminating to MCCB shall be with copper of appropriate current rating. Aluminium is not acceptable due to present construction issues where the size of aluminium bar has been reduced at MCCB terminal point to fit in MCCB slot, which gets burnt out over the time due to its reduced bar size.

- **Interior Lighting and Wiring**

Large transformer distribution board shall be provided with two 230V, 50 Hz, 40W, incandescent lamp fixtures, placed diagonally opposite each other, internally at the top of the pillar, for interior illumination and controlled by limit door switch and 2A fuse link. Whereas for small size pillars, one lamp fixtures controlled by limit door switch is sufficient.

Table 103: Distribution Board Rating for Pole Mounted Transformer

Phase	Transformer Rating (kVA)	LV Current (A)	DB Specification
3	10	13.91	TPN DB with 100 amps Bus bar, incomer through 63 amps TP MCCB, 2ways/4ways outgoing with 63amps HRC fuse (6HRC fuses/12HRC fuses)

3	16	22.26	TPN DB with 100 amps Bus bar, incomer through 63 amps TP MCCB, 2ways/4ways outgoing with 63amps HRC fuse (6HRC fuses/12HRC fuses)
3	25	34.78	TPN DB with 100 amps Bus bar, incomer through 63 amps TP MCCB, 2ways/4ways outgoing with 63amps HRC fuse (6HRC fuses/12HRC fuses)
3	63	87.65	TPN DB with 200 amps Bus bar, incomer through 100 amps TP MCCB, 4ways outgoing with 100amps HRC fuse (12HRC fuse)
3	125	173.91	TPN DB with 300 amps Bus bar, incomer through 250 amps TP MCCB, 4ways outgoing with 200 amps HRC fuse (12HRC fuse)
1	10	41.67	SPN with 100 amps Bus bar, incomer through 63 amps SP MCCB, 2ways/3ways outgoing with 63 amps HRC fuse (2HRC fuses/3HRC fuses)
1	16	66.67	SPN with 100 amps Bus bar, incomer through 100 amps SP MCCB, 2ways/3ways outgoing with 100amps HRC fuse (2HRC fuses/3HRC fuses)
1	25	104.7	SPN with 200 amps Bus bar, incomer through 160 amps SP MCCB, 3ways outgoing with 100amps HRC fuse (3HRC fuses)

Transformer Distribution boards for rural network will require 2 spare fuse for connection to new upcoming households.

Table 104: LV Distribution Board Specification for Pad Mounted Transformer

Phase	Transformer Rating (kVA)	LV Current (A)	DB Specification
3	250	347.80	TPN DP with 400 amps Bus bar, 4ways outgoing with 400 amps HRC fuse (12HRC fuse)
3	315	438.23	TPN DP with 600 amps Bus bar, 6ways outgoing with 500 amps HRC fuse (18HRC fuse)
3	500	695.60	TPN DP with 800 amps Bus bar, 6ways outgoing with 800 amps HRC fuse (18HRC fuse)

Mini Feeder Pillars are used for feeding consumers from Ring /Loop networks. Therefore a mini feeder pillar doesn't have incoming MCCB and outgoing HRC fuse protection. Mini feeder pillar comes with aluminum bus bars with nuts and bolts to connect cable lugs of different sizes. Mini feeder pillar shall also have interior lighting facilities similar to transformer distribution pillar. They shall have a degree of protection of IP 55 or better with bottom cable entry to avoid water ingress. The minimum panel thickness shall be 2.5 mm, and there shall be a removable gland plate of minimum 3 mm thickness. There shall be a lockable hinged door with a minimum thickness of 2 mm. Separate aluminium phase and neutral busbars shall be provided.

5.12 Connection of supply to consumer's premises

Supply to consumer premises through a 2 or 4 core overhead cable in situations where consumers are fed from the overhead system and a 2 or 4 core underground cable when fed from an urban underground system.

Drawing DDCCS-BPC-2014-66 shows the connection arrangement for a three phase and single phase consumers. All components except the energy meter shall be provided by the consumer. The energy meter will be provided by BPC.

A new connection should not be livened unless:

- The consumer has installed an MCB as a point of isolation;
- The consumer has installed a stake earth, which is connected to a main earth terminal on the consumer's distribution board;
- There is a link between the earth terminal and the incoming neutral. As shown in the drawing, the configuration of this connection will depend on connection of an ELCB/RCCB.

5.12.1 Consumer Metering

The choice of meter to install in a consumer installation will depend on the expected load. Three types of meter are available:

- Direct connected, where the meter is directly connected to the incoming low voltage supply;
- CT metering, where the meter is indirectly connected to the low voltage supply through a current transformer; and
- High voltage metering, where the consumer is supplied at high voltage and the meter is indirectly connected to the high voltage supply through a high voltage metering unit.

5.12.2 Direct Connected Metering

Direct connected metering should be used when the consumer load is does not 60 A. Standard direct connected meters used by BPC are given in Table.

Table 105: BPC Standard Direct Connected Meters

Phase	Meter Type	Capacity (A)	Class
1	Static	10-60Amps	2
3	Static	5-30Amps	2
	Static	10-80Amps	2

The class of meter indicates its accuracy and the meter capacity indicate the current range over which the accuracy can be assured. Hence a class 2 10/60 A meter can be expected to have a metering accuracy of 2% over a current range of between 10 and 60 amps.

5.12.3 CT Metering

Where the consumer is supplied at low voltage and the expected maximum three phase load is greater than 60 A, current transformer (CT) metering should be used. All current transformers have a 5 A output and feed into a standard 5 A, class 1 static meter. The load shown on the meter needs to be multiplied by the CT ratio to give the actual consumption.

CTs currently used by BPC have a ratio of 100/5, 200/5, 300/5, 400/5, and 500/5 and have an accuracy of class 1 and a burden of 15 VA.

Care must be taken to ensure the correct multiplier is used when measuring consumption using CT metering.

Table 106: BPC Standard CT Connected Meters

CT class	Meter Type	Capacity (A)	Class
X/5	Static	100/5Amps	1
	Static	200/5Amps	1
	Static	300/5Amps	1
	Static	400/5Amps	1

5.12.4 High Voltage Metering

Consumers supplied at high voltage must provide a high voltage metering unit acceptable to BPC. The high voltage metering unit shall incorporate both potential and current transformers. The current transformer shall be class 0.5, have a maximum burden of 15 VA and have either a 1 A or 5 A output. The voltage transformer shall be class 0.5, have a maximum burden of 15 VA and have a 110 V output.

BPC will connect its own class 0.5 trivector electronic meter meeting the requirements of IEC 60687 to the consumer's high voltage metering unit. The meter shall incorporate a data logging facility and be capable of recording a range of different power system parameters at the point of connection.

5.13 Underground Cable Installation

5.13.1 General

- These notes in general cover cables upto and including 33 kV rating.
- Electrical installation work shall comply with all currently applicable statutes, regulations and safety codes in the locality/country where the installation is to be carried out.
- Installation of cables shall be carried out generally as per IS 1255 or relevant applicable IEC standards and enclosed typical drawings.

- Installation of cables shall include unloading, storing, laying, fixing, jointing, termination and all other work necessary for completing the job. Supply of glands and lugs whenever specified, together with necessary materials for jointing and termination shall also be included in Contractor's scope.
- Construction of cable trenches, provision of embedments and similar work involving civil items will be carried out as per the instructions/notes on the respective project drawings and installation specification.
- Cables will be installed in trenches, trays, racks, tunnels, conduits, duct banks or directly buried. The actual cable layouts will be shown on the relevant drawings. Any changes, if necessary, after obtaining prior approval of the Engineer shall be carried out at site by the Contractor and shall be clearly marked by him on drawings.
- Cables to each circuit shall be laid in one continuous length.
- Where cables are to be installed at temperatures below 3 ° C, they shall be heated to about 10 ° C for not less than 24 hours (in a heated building or in a tent with hot air heater) to facilitate laying (otherwise the bending would damage the insulation and protective coverings of cables). The cable laying must be carried out swiftly so as not to allow the cable to cool down too much.
- Instead of cast iron cable route marker, plastic marking tape may be used for UG which shall run along the length of the cable and shall have cable marking at every 1.5meter length.

5.13.2 Outdoor Cable Installation

- Directly buried cables shall be laid as per the drawings and cable route markers shall be provided. MS cable marker to be replaced by plastic marker buried cables in trefoil formation shall be bound by plastic tapes or 3mm dia. nylon core every 750 mm.
- Joints in directly buried cables shall be identified by joint markers at each joint location.
- In each outdoor cable run greater than 50 metre, some extra cable length shall be kept at a suitable point to enable a straight through joint to be made should the cable develop fault at a later date.
- Where cables cross roads, water or sewage pipes, the cable shall be laid in hume or steel pipes. For road crossings the pipe for the cable shall be buried at not less than 600 mm unless otherwise noted in the drawings. Hume pipes shall be preferred to steel pipes from the point of view of corrosion.

- Control cables and small power cables in trenches and tunnels shall be run in ladder type cable trays (maximum tray width 600 mm) supported on trench/tunnel carrier arms. The cables shall be laid to tray rungs by means of 3mm dia. nylon cord at an interval of 5000 mm and also at bends.
- For good sealing arrangement at entry points, suitable pipe sleeves, adequate in number and of adequate sizes shall be provided in building walls/slabs for passage of cables into a building from cable trays/racks/cable trenches located outside the buildings.

5.13.3 Bending Radii for Cables

The bending radii for various types of cables shall not be less than those specified below, unless specifically approved by the Engineer.

Description	Single Core	Multicores Armoured	Multicores Unarmoured
PVC insulated cable upto 11 kV	20 D	12 D	15 D

Where D = Overall diameter of cable.

(For XLPE insulated cables, recommendations of manufacturers to be followed).

The above values may be reduced to 70% when making only one bend such as in case of installing an end termination

5.13.4 Terminations Clamping & Miscellaneous Details

- Cable entry to motors, push button stations and other electrical devices shall be from the bottom as far as possible or from the sides. Top entry shall be avoided particularly for outdoor equipment.
- Identification tags made from aluminium sheet shall be attached to each end of each cable by means of GI binding wire as shown in drawing. Tags shall be additionally put at an interval of 30 meters on long runs of cables and in pull boxes.
- All cable terminations shall be solderless crimping type. Whenever lugs are required to be supplied, adequate size crimping lugs of approved make shall be used by the Contractor. The crimping tools shall be adequate for the lug sizes.
- Wooden cleats when required for vertically supporting on or more single core cables per phase, such as on vertical framework near transformer cable boxes, shall be made out of well seasoned wood given two coats of fire retarding paint of approved quality.

5.13.5 Earthing of Cables

- Metallic sheaths, screens and armour of all multi-core cables shall be earthed at both equipment and switchgear end.
- Sheath and armour of single core power cables shall be earthed at switchgear end only. If specifically indicated in drawings, for long lengths of cables multiple earthing may have to be adopted to safeguard against the presence of standing voltage under normal as well as fault conditions.
- Earthing of CT and PT neutral lead shall be at one end only.

LIST OF DRAWINGS

Sl. No.	Drawing no:	Description
1	BPC-DDCS-2015-9	Termination Pole Substation Type “A” Arrangement
2	BPC-DDCS-2015-10	Intermediate Pole Substation Type “B” Arrangement
3	BPC-DDCS-2015-11	Tension Pole Substation Type “C” Arrangement
4	BPC-DDCS-2015-12	11 kV, D-ckt Pole Structure
5	BPC-DDCS-2015-13	33 kV, D-ckt Pole Structure
6	BPC-DDCS-2015-14	LV ABC Typical Service layout Arrangement
7	BPC-DDCS-2015-15	LV ABC Intermediate and Angle Pole Details
8	BPC-DDCS-2015-16	LV ABC Termination and Anchor Pole Details
9	BPC-DDCS-2015-17	LV ABC Tee Pole Details
10	BPC-DDCS-2015-18	7.5 meter Steel Tubular Pole Assembly Details
11	BPC-DDCS-2015-19	7.5 meter Steel Tubular Pole Details
12	BPC-DDCS-2015-20	10 meter Steel Tubular Pole Assembly Details
13	BPC-DDCS-2015-21	10 meter Steel Tubular Pole Details
14	BPC-DDCS-2015-22	12 meter Steel Tubular Pole
15	BPC-DDCS-2015-23	12 meter Steel Tubular Pole Details
16	BPC-DDCS-2015-24	11.2 meter Telescopic Pole Details
17	BPC-DDCS-2015-25	12 meter Telescopic Pole Details
18	BPC-DDCS-2015-26	Foot Bars for Telescopic Poles
19	BPC-DDCS-2015-27	Anti-climbing Device
20	BPC-DDCS-2015-28	Danger Plates
21	BPC-DDCS-2015-29	Clamp Details for Telescopic Pole
22	BPC-DDCS-2015-30	Clamp Details for Steel Tubular Pole
23	BPC-DDCS-2015-31	Single Pole Assembly -Steel Tubular Pole
24	BPC-DDCS-2015-32/1	11 kV & 33 kV H-Frame-Double Pole Arrangement (Steel Tubular Pole)
25	BPC-DDCS-2015-32/2	11 kV & 33 kV H-Frame-Channel& Bracing Detail (Steel Tubular Pole)
26	BPC-DDCS-2015-32/3	11 kV & 33 kV H-Frame-Channel& Bracing Detail (Steel Tubular Pole)
27	BPC-DDCS-2015-33/1	Single Pole Assembly -Telescopic Pole (11.2meter)
28	BPC-DDCS-2015-33/2	Single Pole Cross-arm Assembly -Telescopic Pole (11.2meter)
29	BPC-DDCS-2015-34/1	Double Pole Assembly -Telescopic Pole (11.2meter)
30	BPC-DDCS-2015-34/2	Double Pole Cross-arm Assembly -Telescopic Pole (11.2meter)
31	BPC-DDCS-2015-35/1	Single Pole Assembly -Telescopic Pole (12meter)
32	BPC-DDCS-2015-35/2	Single Pole Cross-arm Assembly -Telescopic Pole (12meter)
33	BPC-DDCS-2015-35/3	U-bolt for Shielding Wire for Single Pole Structure
34	BPC-DDCS-2015-36/1	Double Pole Cross-arm Assembly -Telescopic Pole (12meter)
35	BPC-DDCS-2015-36/2	Double Pole Cross-arm Assembly -Telescopic Pole (12meter)

36	BPC-DDCS-2015-36/3	Double Pole Cross-arm Assembly for Shielding Wire - Telescopic Pole (12meter)
37	BPC-DDCS-2015-37/1	Pole Mounted Transformer Structure for Steel Tubular Pole
38	BPC-DDCS-2015-37/2	Transformer Plateform for Steel Tubular Pole
39	BPC-DDCS-2015-38/1	Pole Mounted Transformer Structure for Telescopic Pole (11.2meter)
40	BPC-DDCS-2015-38/2	Pole Mounted Transformer Structure Cross-arm for Telescopic Pole (11.2meter)
41	BPC-DDCS-2015-38/3	Pole Mounted Transformer Structure Cross-arm for Telescopic Pole (11.2meter)
42	BPC-DDCS-2015-39/1	Pole Mounted Transformer Structure for Telescopic Pole (12meter)
43	BPC-DDCS-2015-39/2	Pole Mounted Transformer Structure Cross-arm for Telescopic Pole (12meter)
44	BPC-DDCS-2015-39/3	Pole Mounted Transformer Structure Cross-arm for Telescopic Pole (12meter)
45	BPC-DDCS-2015-40/1	11 kV and 33 kV ABS Arrangement for Steel Tubular Pole
46	BPC-DDCS-2015-40/2	ABS Cross-arm Assembly for Steel Tubular Pole
47	BPC-DDCS-2015-41/1	11 kV and 33 kV ABS Arrangement for 11.2M Telescopic Pole
48	BPC-DDCS-2015-41/2	11 kV and 33 kV ABS Arrangement for 12M Telescopic Pole
49	BPC-DDCS-2015-41/3	ABS Cross-arm Assembly for 11.2M & 12M Telescopic Pole
50	BPC-DDCS-2015-42/1	Typical ARCB Arrangement on Steel Tubular Pole
51	BPC-DDCS-2015-42/2	Cross-arm Assembly for Mounting ARCB on Steel Tubular Pole
52	BPC-DDCS-2015-43/1	33 kV Procelain Pin Insualtor-Large Head
53	BPC-DDCS-2015-43/2	11 kV Procelain Pin Insualtor- Small Head
54	BPC-DDCS-2015-44	11 & 33 kV Composite Silicon Rubber Pin Insulator
55	BPC-DDCS-2015-45	Procelain and Composite Silicon Rubber Disc Insulator
56	BPC-DDCS-2015-46	Assemblies for Disc Insulator Arrangement
57	BPC-DDCS-2015-47	Hardware Fittings for Disc Insulator Arrangement
58	BPC-DDCS-2015-48	Stay Insulators
59	BPC-DDCS-2015-49	Spike Earthing Set
60	BPC-DDCS-2015-50	Pipe Earthing Set
61	BPC-DDCS-2015-51	Stay Assembly Set
62	BPC-DDCS-2015-52	General Arrangement of 4 ways Unitized Substation
63	BPC-DDCS-2015-53/1	Single Phase Transformer LT Panel, Incomer MCCB upto 125Amps, HRC Fuse upto 125Amps (Internal View)
64	BPC-DDCS-2015-53/2	Single Phase Transformer LT Panel, Incomer MCCB upto 125Amps, HRC Fuse upto 125Amps (External View)
65	BPC-DDCS-2015-54/1	Three Phase Transformer LT Panel , Incomer MCCB upto 200Amps, HRC Fuse upto 63Amps (Internal View)

66	BPC-DDCS-2015-54/2	Three Phase Transformer LT Panel , Incomer MCCB upto 200Amps, HRC Fuse upto 63Amps (External View)
67	BPC-DDCS-2015-55	Mini Feeder Pillar 76 BPC-DDCS-2015-56/1 4 Ways Transformer Distribution Pillar (Front Elevation)
68	BPC-DDCS-2015-56/2	4 Ways Transformer Distribution Pillar (Side Elevation)
69	BPC-DDCS-2015-56/3	4 Ways Transformer Distribution Pillar (Front Elevation without Door)
70	BPC-DDCS-2015-56/4	4 Ways Transformer Distribution Pillar (Gland Plate Details)
71	BPC-DDCS-2015-56/5	4 Ways Transformer Distribution Pillar (Foundation Details and Lighting Circuit)
72	BPC-DDCS-2015-57/1	6 Ways Transformer Distribution Pillar (Front Elevation)
73	BPC-DDCS-2015-57/2	6 Ways Transformer Distribution Pillar (Side Elevation)
74	BPC-DDCS-2015-57/3	6 Ways Transformer Distribution Pillar (Front Elevation without Door)
75	BPC-DDCS-2015-57/4	6 Ways Transformer Distribution Pillar (Gland Plate Details)
76	BPC-DDCS-2015-57/5	6 Ways Transformer Distribution Pillar (Foundation Details and Lighting Circuit)
77	BPC-DDCS-2015-58	Typical Details of 11 kV and 33 kV Fuse Cutout
78	BPC-DDCS-2015-59	Typical Arrangement of 11 kV and 33 kV Air Break Switch
79	BPC-DDCS-2015-60/1-2	Arrangement of Bow Guy and Fly-Guy
80	BPC-DDCS-2015-61	Arrangement of Conductors at Angle Location - 4 pole structure (60 degree to 90 degree location)
81	BPC-DDCS-2015-62	Details of Guarding for 11 kV and 33 kV System
82	BPC-DDCS-2015-64	33 kV /11 kV/.415 kV Substation Pipe Earthing
83	BPC-DDCS-2015-65	Distribution Substation typical Earthing Arrangement
84	BPC-DDCS-2015-66	Consumer Connection Arrangements
85	BPC-DDCS-2020-1A&1D	Directly Buried Cables with & without Conduit
86	BPC-DDCS-2020-1B,C&1C	Details of UG Cables in Trench
87	BPC-DDCS-2020-33	Chain Link Fencing for Substation (10 m x 10 m)
88	BPC-DDCS-2020-37A	Unitized Substation Foundation-11kV (7 Ton)
89	BPC-DDCS-2020-37B	Unitized Substation Foundation-33kV (9 Ton)
90	BPC-DDCS-2020-37C	Unitized Substation Foundation-33kV (8 Ton)
91	BPC-DDCS-2020-38	Transformer Foundation up to 500kVA (2.5 Ton)
92	BPC-DDCS-2020-39	Typical RMU (6 ways) Foundation Drawing

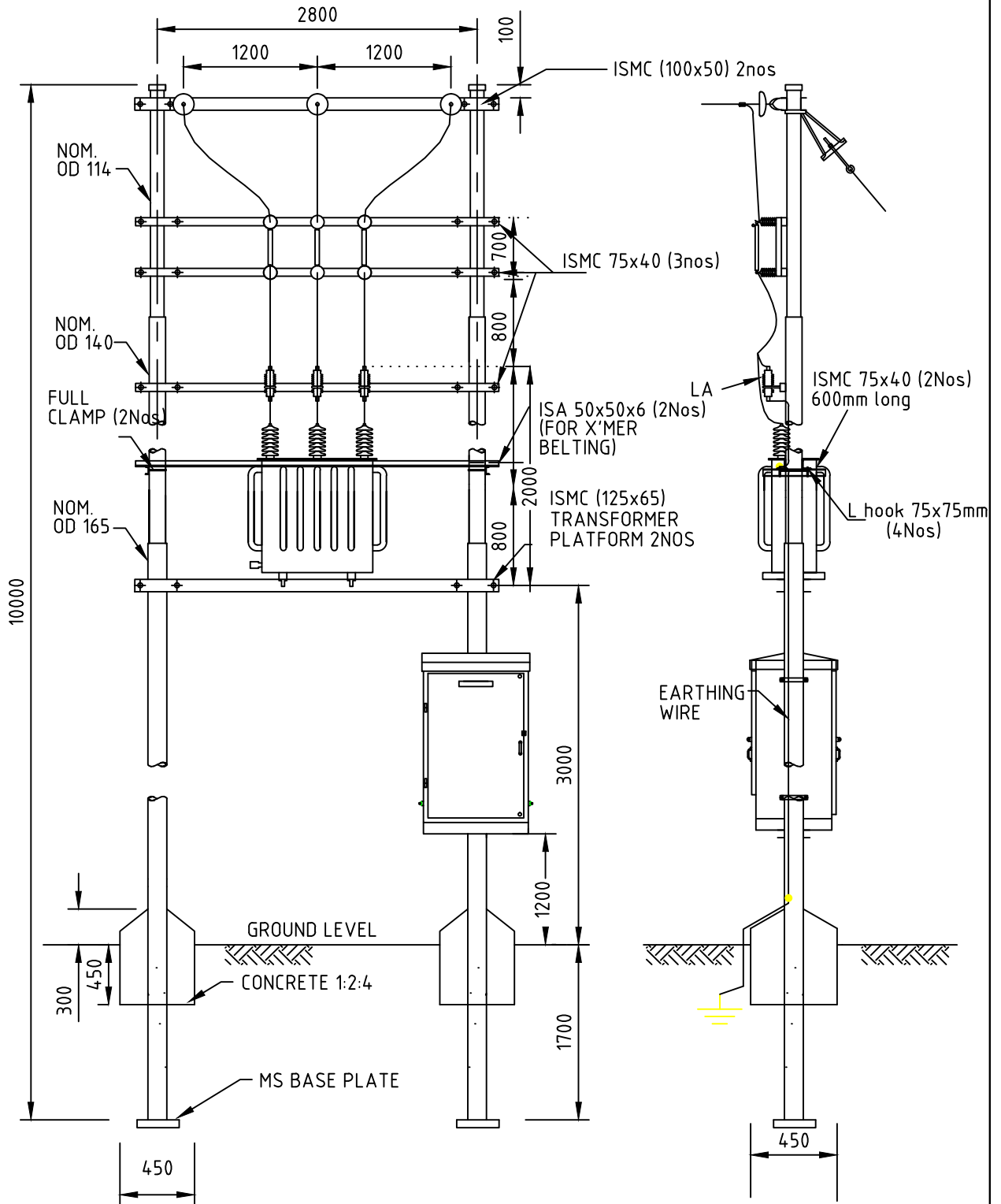

NOTES

1. DIMENSIONS AS SHOWN ARE IN mm.
2. MOUNTING HEIGHT OF THE TOP DO FUSE TO BE ADJUSTED WITHIN 6M FOR USE OF HOT STICK

 <p>BHUTAN POWER CORPORATION LIMITED</p>	ENGINEERING DESIGN & CONTRACTS DEPARTMENT	
	DISTRIBUTION DESIGN & CONSTRUCTION STANDARD	
TERMINATION POLE SUBSTATION TYPE "A" ARRANGEMENT		
DESIGNATION	NAME	DATE
DRAFTSMAN		
DESIGNER		
DESIGN CHECK		
PROJECT MANAGER		
PROJECT DIRECTOR		
DRAWING NO. BPC-DDCS-2015-9		REVISION 2015

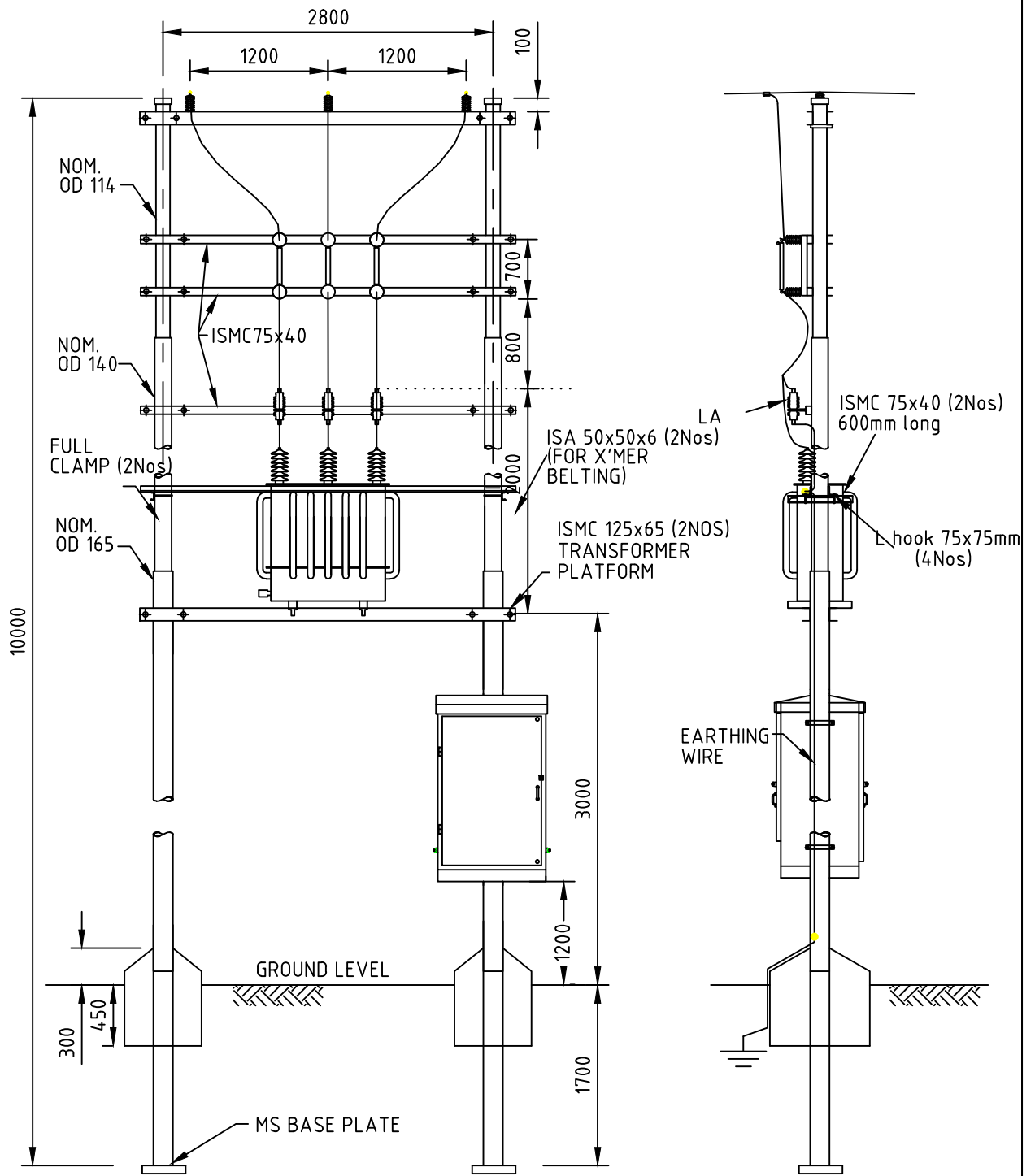

NOTES

1. DIMENSIONS AS SHOWN ARE IN mm.
2. MOUNTING HEIGHT OF THE TOP DO FUSE TO BE ADJUSTED WITHIN 6M FOR USE OF HOT STICK

 <p>BHUTAN POWER CORPORATION LIMITED</p>	ENGINEERING & DESIGN DIVISION		
	DISTRIBUTION DESIGN & CONSTRUCTION STANDARD		
	INTERMEDIATE POLE SUBSTATION TYPE "B" ARRANGEMENT		
DESIGNATION	NAME	DATE	
DRAFTSMAN			
DESIGNER			
DESIGN CHECK			
PROJECT MANAGER			
PROJECT DIRECTOR			
DRAWING NO. BPC-DDCS-2015-10			REVISION 2015

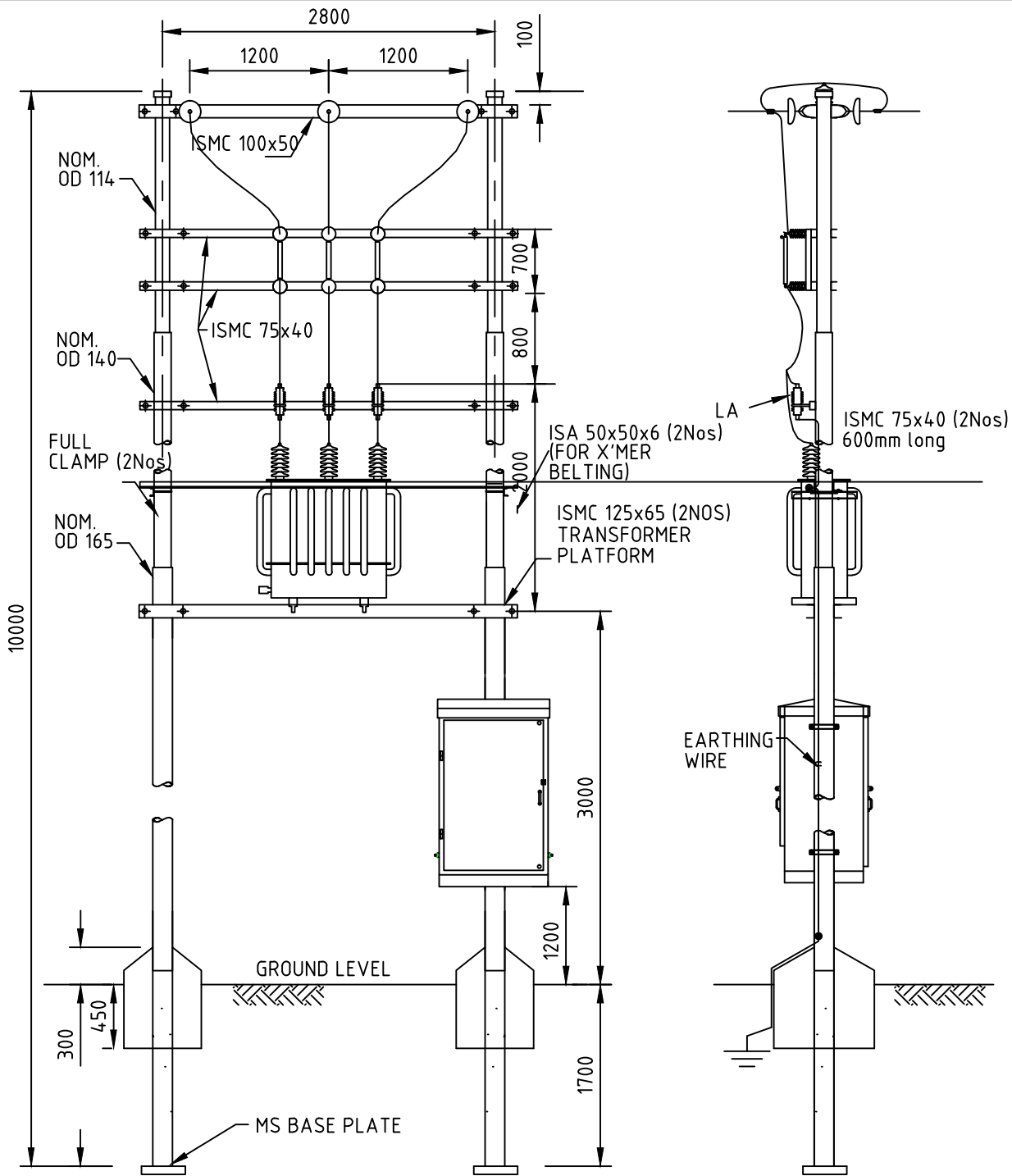

NOTES

1. DIMENSIONS AS SHOWN ARE IN mm.
2. MOUNTING HEIGHT OF THE TOP DO FUSE TO BE ADJUSTED WITHIN 6M FOR USE OF HOT STICK

 <p>BHUTAN POWER CORPORATION LIMITED</p>	ENGINEERING DESIGN & CONTRACTS DEPARTMENT	
	DISTRIBUTION DESIGN & CONSTRUCTION STANDARD	
TENSION POLE SUBSTATION TYPE " C " ARRANGMENT		
DESIGNATION	NAME	DATE
DRAFTSMAN		
DESIGNER		
DESIGN CHECK		
PROJECT MANAGER		
PROJECT DIRECTOR		
DRAWING NO. BPC-DDCS-2015-11		REVISION 2015

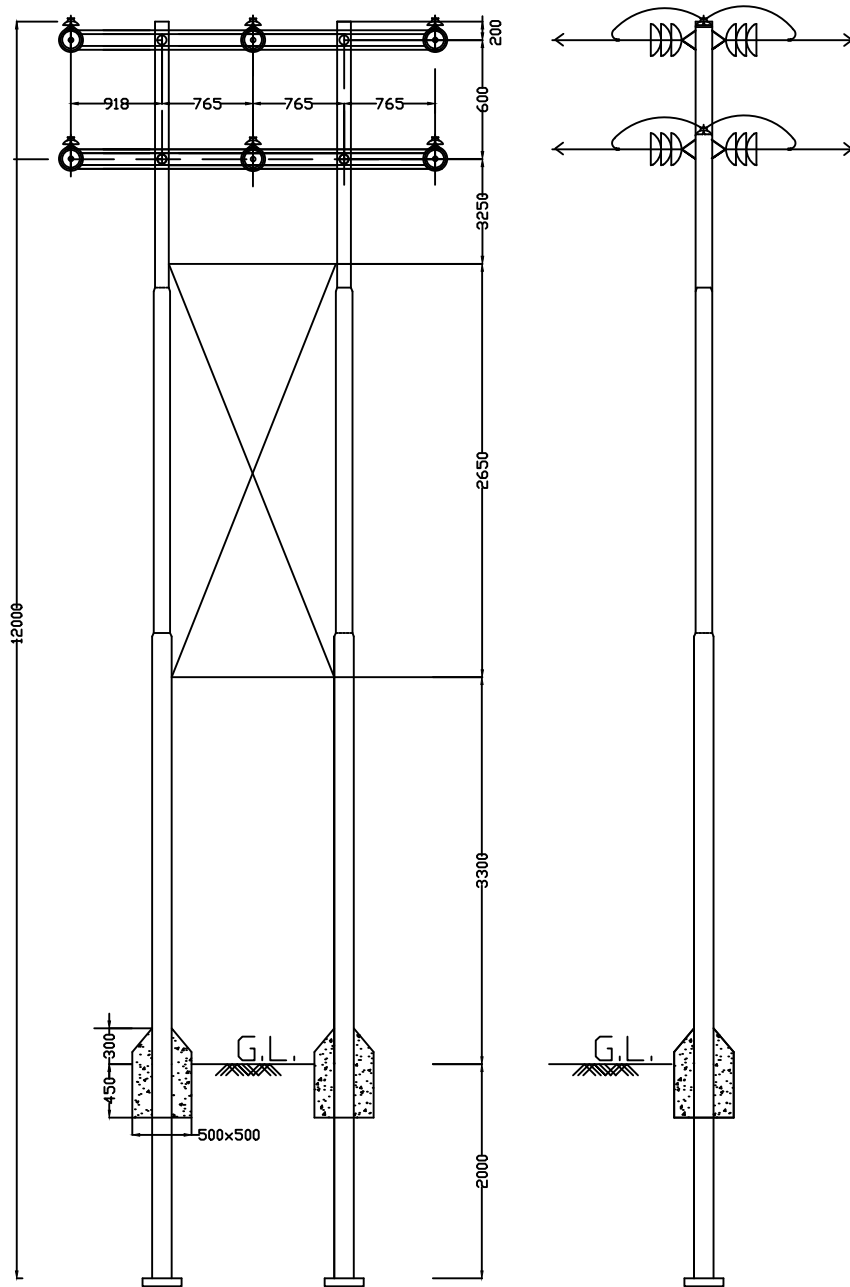

BHUTAN POWER CORPORATION LIMITED

ENGINEERING DESIGN & CONTRACTS DEPARTMENT

DISTRIBUTION DESIGN & CONSTRUCTION STANDARD

11 kV, D - CKT, POLE STRUCTURE (HORIZONTAL CONFIGURATION)

DESIGNATION	NAME	DATE
DRAFTSMAN		
DESIGNER		
DESIGN CHECK		
PROJECT MANAGER		
PROJECT DIRECTOR		

DRAWING NO. BPC-DDCS-2015-12/A

REVISION
2015

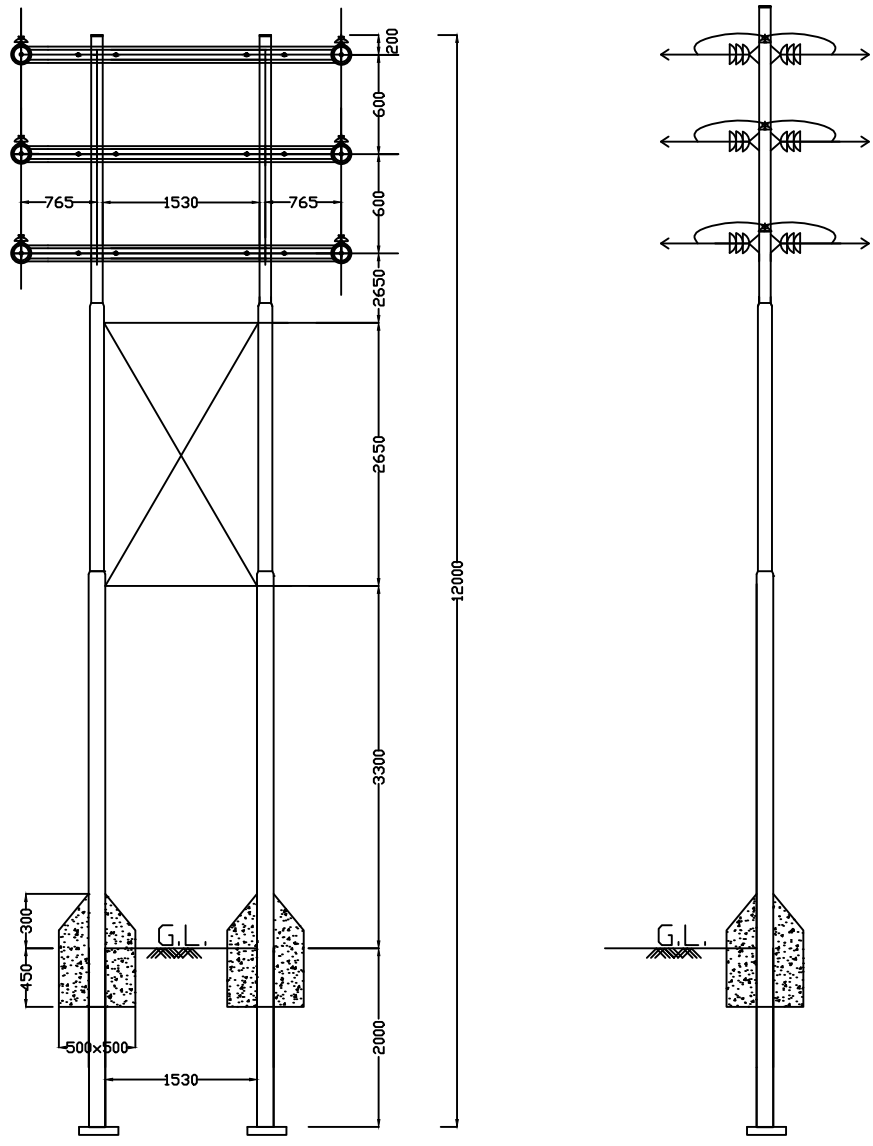

BHUTAN POWER CORPORATION LIMITED

ENGINEERING DESIGN & CONTRACTS DEPARTMENT

DISTRIBUTION DESIGN & CONSTRUCTION STANDARD

11 kV, D - CKT, POLE STRUCTURE (VERTICAL CONFIGURATION)

DESIGNATION	NAME	DATE
DRAFTSMAN		
DESIGNER		
DESIGN CHECK		
PROJECT MANAGER		
PROJECT DIRECTOR		

DRAWING NO. BPC-DDCS-2015-12/B

REVISION
2015

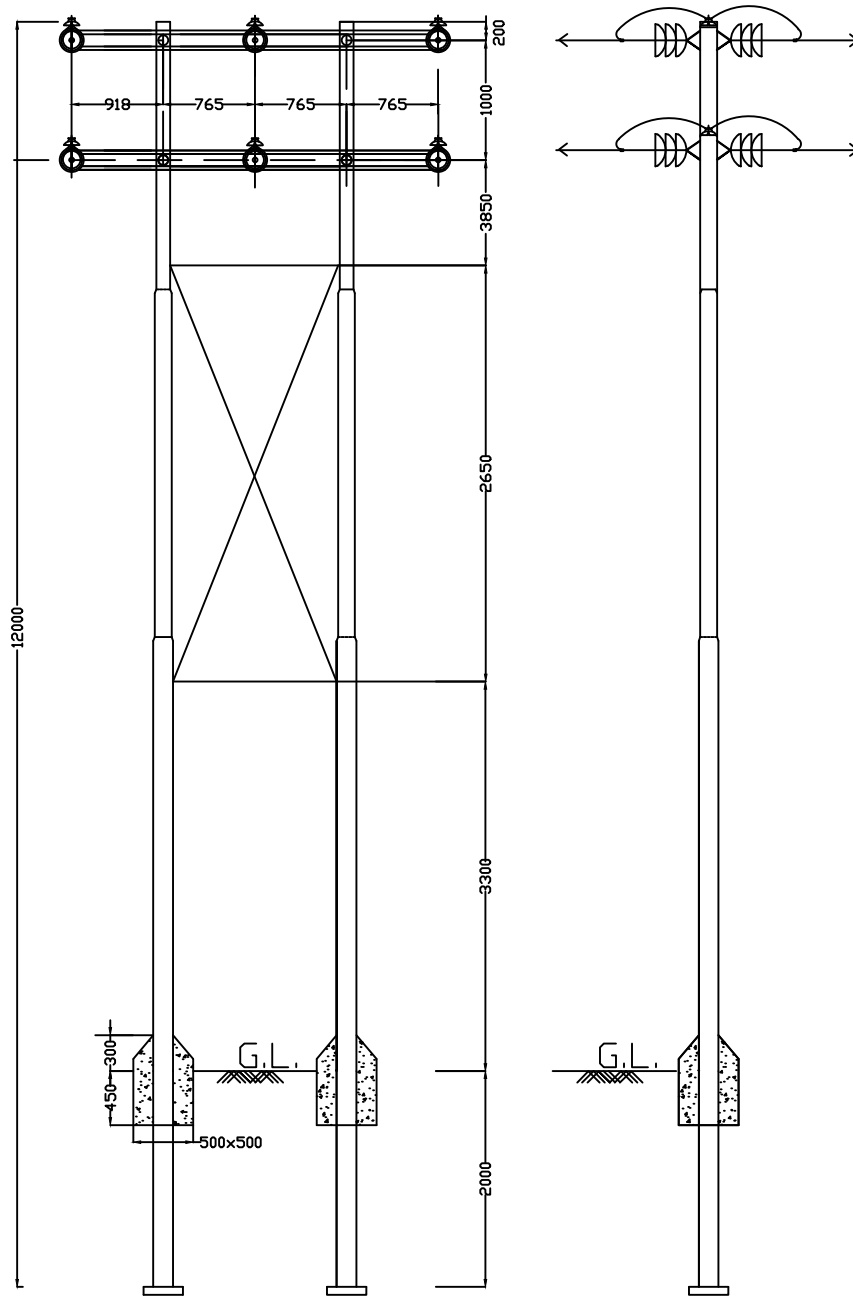

BHUTAN POWER CORPORATION LIMITED

ENGINEERING DESIGN & CONTRACTS DEPARTMENT

DISTRIBUTION DESIGN & CONSTRUCTION STANDARD

33 kV, D - CKT, POLE STRUCTURE (HORIZONTAL CONFIGURATION)

DESIGNATION	NAME	DATE
DRAFTSMAN		
DESIGNER		
DESIGN CHECK		
PROJECT MANAGER		
PROJECT DIRECTOR		

DRAWING NO. BPC-DDCS-2015-13/A

REVISION
2015

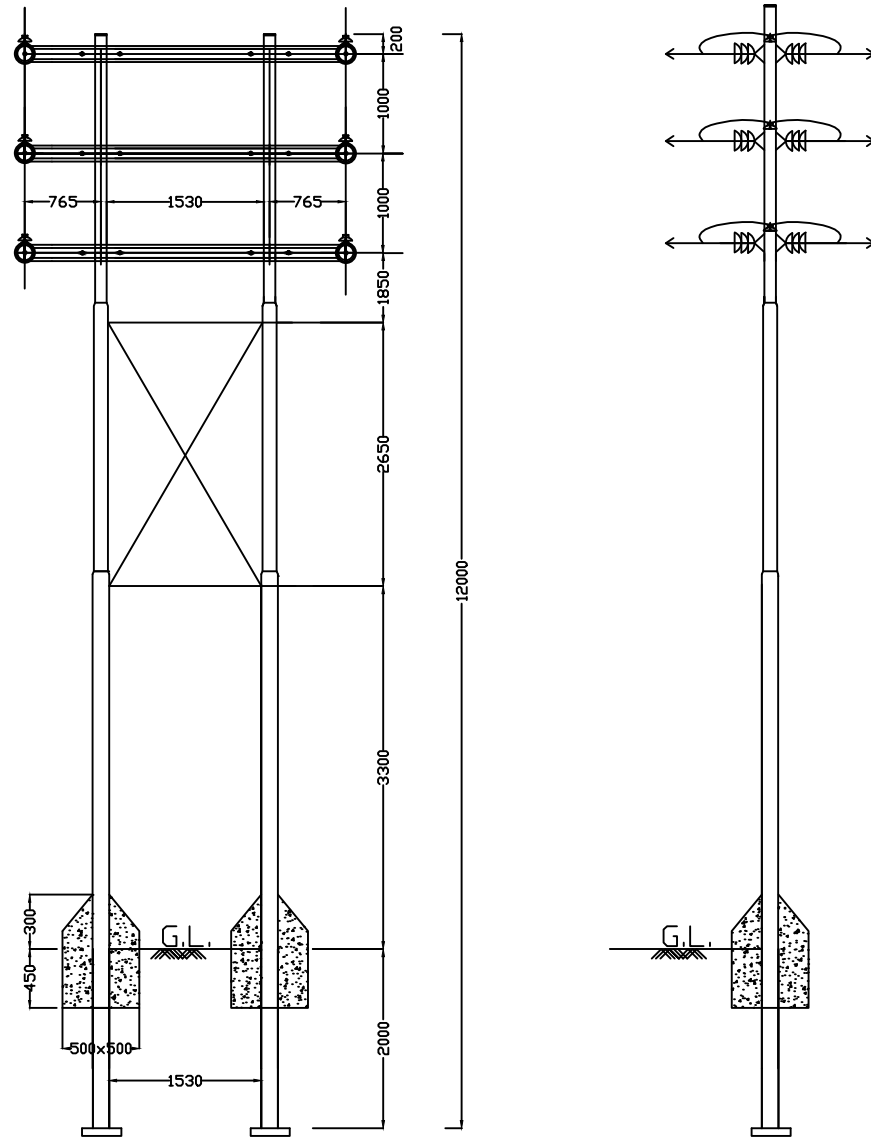

BHUTAN POWER CORPORATION LIMITED

ENGINEERING DESIGN & CONTRACTS DEPARTMENT

DISTRIBUTION DESIGN & CONSTRUCTION STANDARD

33 kV, D - CKT, POLE STRUCTURE (VERTICAL CONFIGURATION)

DESIGNATION	NAME	DATE
DRAFTSMAN		
DESIGNER		
DESIGN CHECK		
PROJECT MANAGER		
PROJECT DIRECTOR		

DRAWING NO. BPC-DDCS-2015-13/B

REVISION
2015

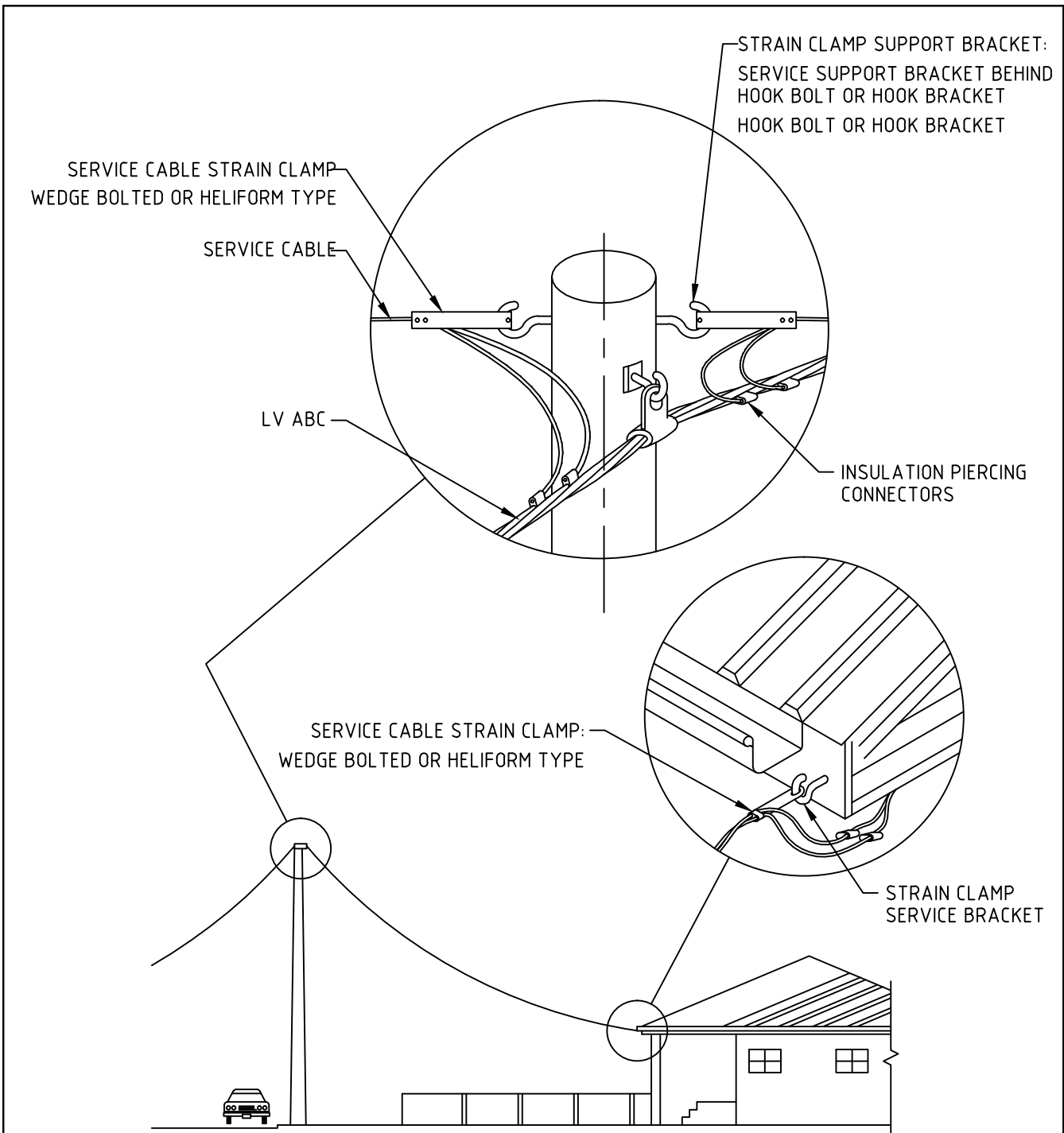

NOTES

1. DIMENSIONS AS SHOWN ARE IN mm.
2. DRAWING IS NOT TO SCALE.



BHUTAN POWER CORPORATION LIMITED

ENGINEERING DESIGN & CONTRACTS DEPARTMENT

DISTRIBUTION DESIGN AND CONSTRUCTION STANDARDS

LV ABC TYPICAL SERVICE LAYOUT ARRANGEMENT

DESIGNATION	NAME	DATE
DRAFTSMAN		
DESIGNER		
DESIGN CHECK		
PROJECT MANAGER		
PROJECT DIRECTOR		

DRAWING NO. BPC - DDCS - 2015 - 14

REVISION
2015

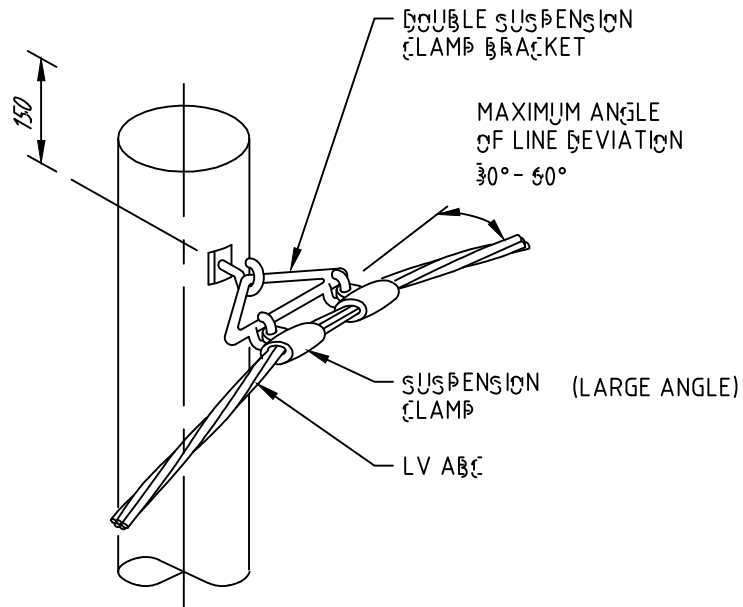
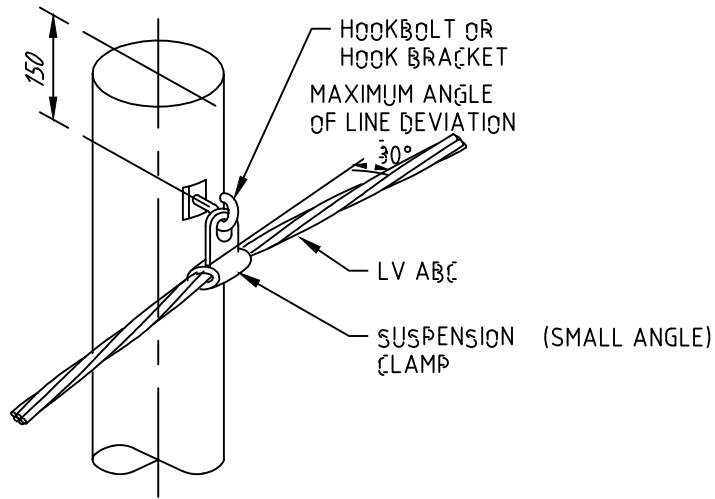

NOTES

1. DIMENSIONS AS SHOWN ARE IN mm.
2. DRAWING IS NOT TO SCALE.



BHUTAN POWER CORPORATION LIMITED

ENGINEERING DESIGN & CONTRACTS DEPARTMENT

DISTRIBUTION DESIGN & CONSTRUCTION STANDARD

**LV ABC
INTERMEDIATE & ANGLE POLES DETAILS**

DESIGNATION	NAME	DATE
DRAFTSMAN		
DESIGNER		
DESIGN CHECK		
PROJECT MANAGER		
PROJECT DIRECTOR		

DRAWING NO. BPC-DDCS-2015-15

REVISION
2015

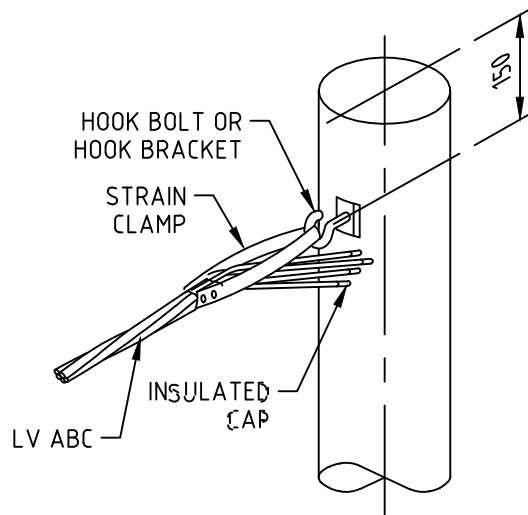

ALLOW SUFFICIENT CABLE TAIL TO ALLOW FOR FUTURE EXTENSION

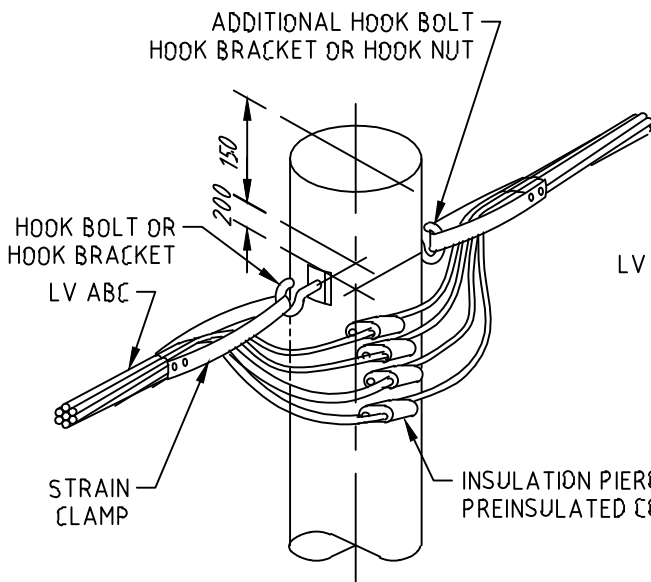

FIELD CONDITIONS MAY ALLOW CABLE TO BE CONTINUOUS AT POLE

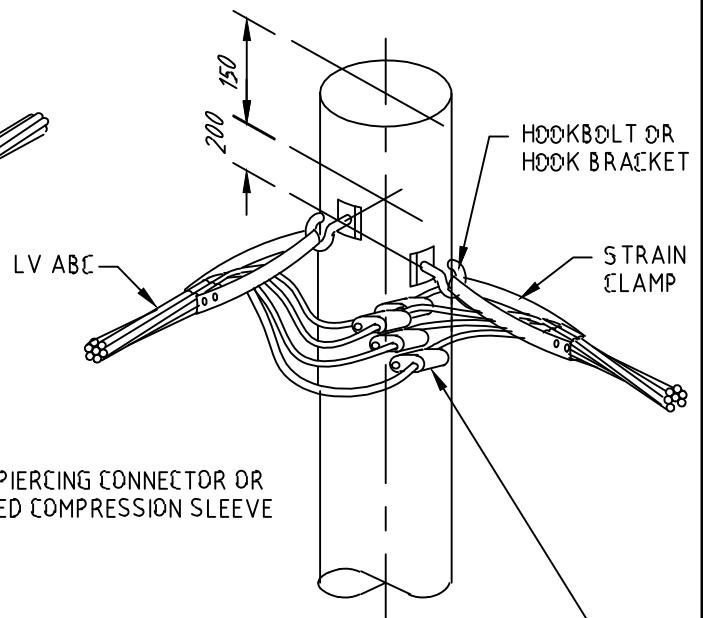

INSULATION PIERCING CONNECTOR OR PREINSULATED COMPRESSION SLEEVE

NOTES

1. DIMENSIONS AS SHOWN ARE IN mm.
2. DRAWING IS NOT TO SCALE.



BHUTAN POWER CORPORATION LIMITED

ENGINEERING DESIGN & CONTRACTS DEPARTMENT

TITLE : DISTRIBUTION DESIGN & CONSTRUCTION STANDARD
LV ABC TERMINATION & ANCHOR POLES DETAILS

DESIGNATION	NAME	DATE
DRAFTSPERSON		
DESIGNER		
PROJECT MANAGER		
HEAD OF DEPARTMENT		

DRAWING NO. BPC - DDCS - 2015-16

REV 2015

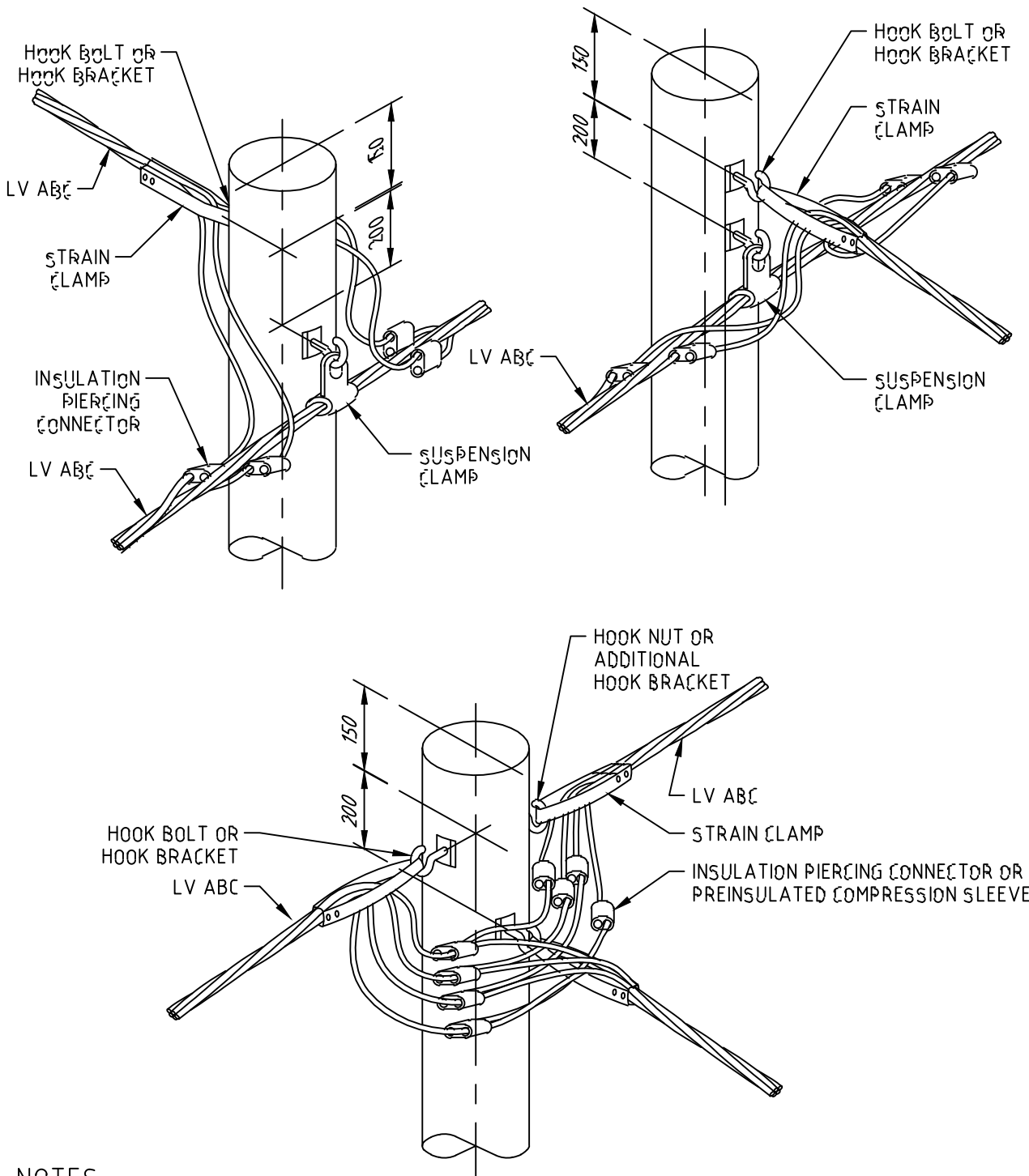

NOTES

1. DIMENSIONS AS SHOWN ARE IN mm.
2. DRAWING IS NOT TO SCALE.



BHUTAN POWER CORPORATION LIMITED

ENGINEERING DESIGN & CONTRACTS DEPARTMENT

**DISTRIBUTION DESIGN & CONSTRUCTION STANDARD
LV ABC TEE POLE DETAILS**

DESIGNATION	NAME	DATE
DRAFTSPERSON		
DESIGNER		
PROJECT MANAGER		
HEAD OF DEPARTMENT		

DRAWING NO. BPC - DDCS - 2015-17

REVISION
2015

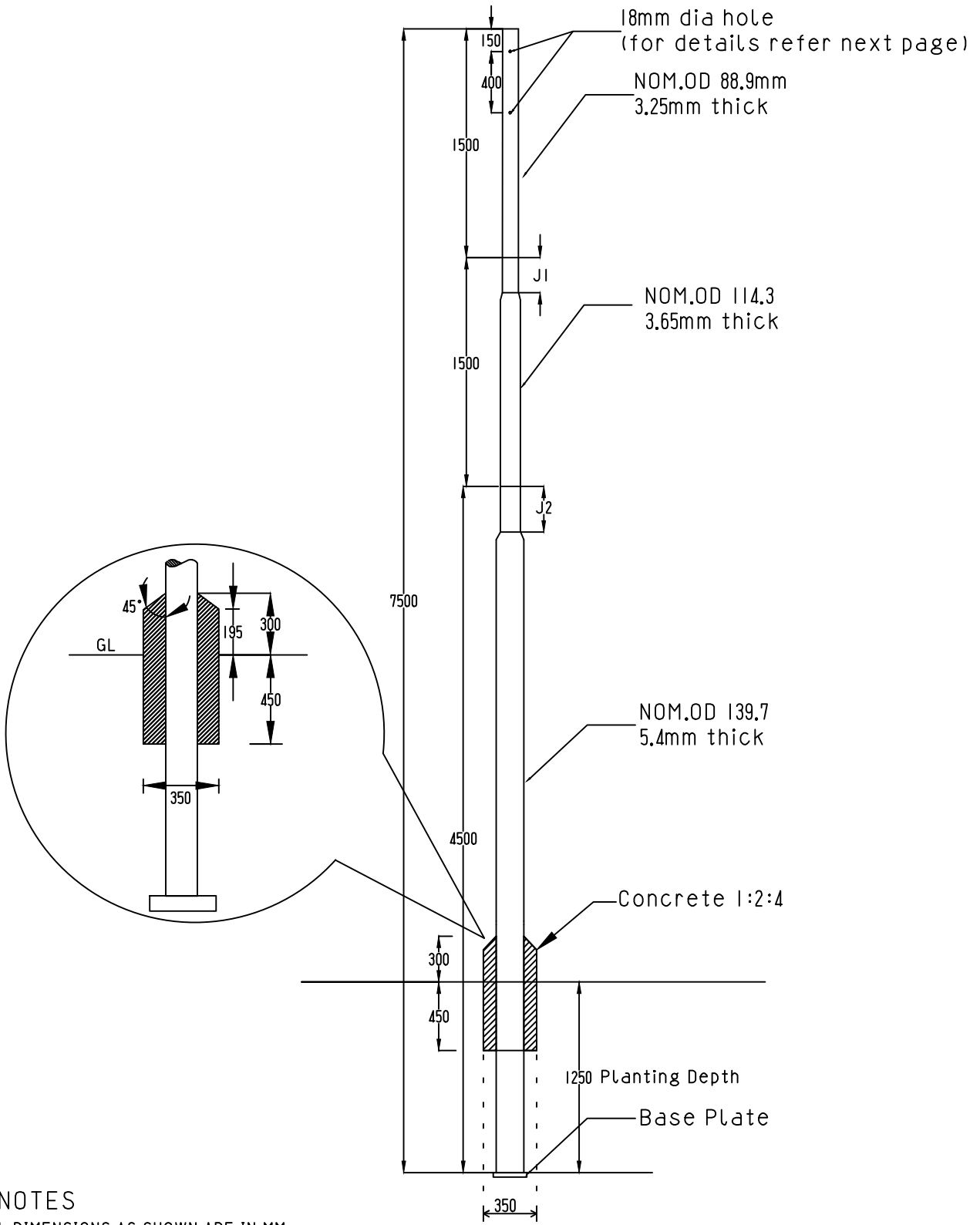

- NOTES**
1. DIMENSIONS AS SHOWN ARE IN MM.
 2. SPECIFICATIONS AS PER IS:2713 (PART I TO III : 1980)
 3. POLE TOP CAP -M.S. PLATE WOULD BE TAG WELDED TO THE POLE



BHUTAN POWER CORPORATION LIMITED

ENGINEERING DESIGN & CONTRACTS DEPARTMENT

DISTRIBUTION DESIGN & CONSTRUCTION STANDARD

7.5 METERS SWAGED POLE ASSEMBLY

DESIGNED BY	NAME	DATE
CHECKED BY		
APPROVED BY		

DRAWING NO. BPC-DDCS-2015-18

REVISION 2015

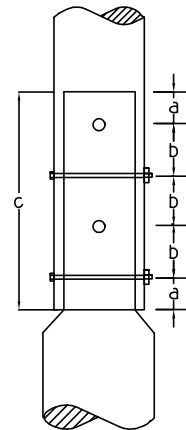
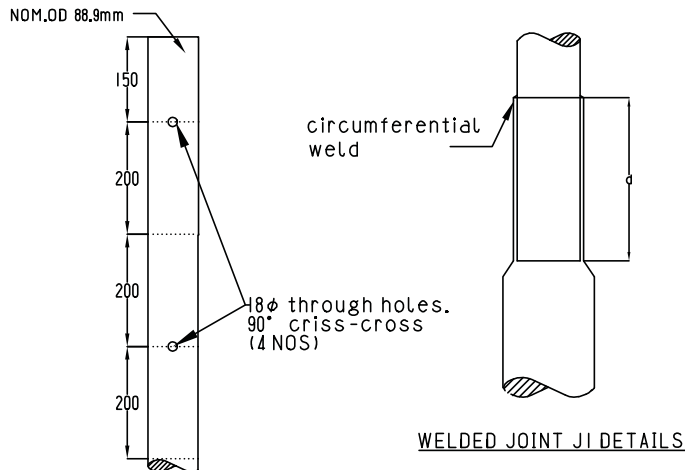

POLE TOP DETAILS

BOLTED JOINT J2 DETAILS

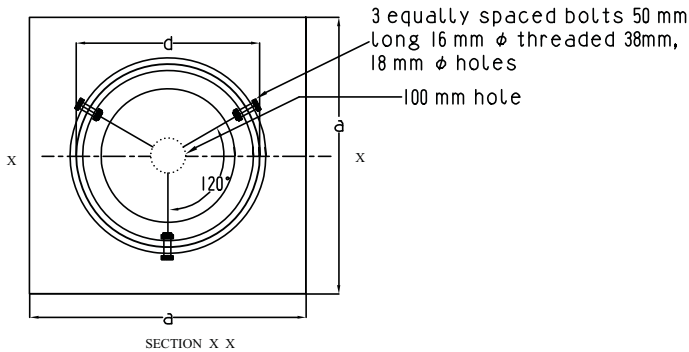
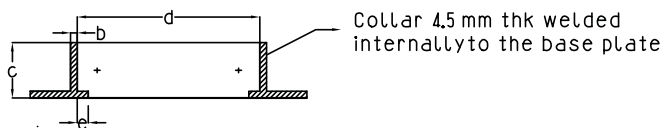
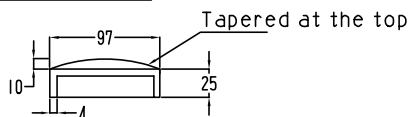

Pole Type		7.5 M (410-SP-9)	
Length		mm	7500
Top Segment	OD	mm	88.9
	Thickness	mm	3.25
Length		mm	1500
Middle Segment	OD	mm	114.3
	Thickness	mm	3.65
Length		mm	1500
Bottom Segment	OD	mm	139.7
	Thickness	mm	5.4
Length		mm	4500
Joint J1	Welded Joint		
	d	mm	230
Joint J2	a	mm	45
	b	mm	70
	c	mm	300
	BL	mm	160
Planting Depth		mm	1250
Base plate details	a	mm	220
	b	mm	4.5
	c	mm	70
	d	mm	139.7
	e	mm	10

NOTES

1. DIMENSIONS AS SHOWN ARE IN MM.
2. DRAWING NOT TO SCALE.
3. SPECIFICATIONS AS PER IS:2713 (PART I TO III : 1980)
4. POLE TOP CAP -M.S. PLATE WOULD BE TAG WELDED TO THE POLE



BHUTAN POWER CORPORATION LIMITED

ENGINEERING DESIGN & CONTRACTS DEPARTMENT

DISTRIBUTION DESIGN & CONSTRUCTION STANDARD

7.5 METERS SWAGED POLE DETAILS

	NAME	DATE
DESIGNED BY		
CHECKED BY		
APPROVED BY		

DRAWING NO. BPC-DDCS-2015-19

REVISION
2015

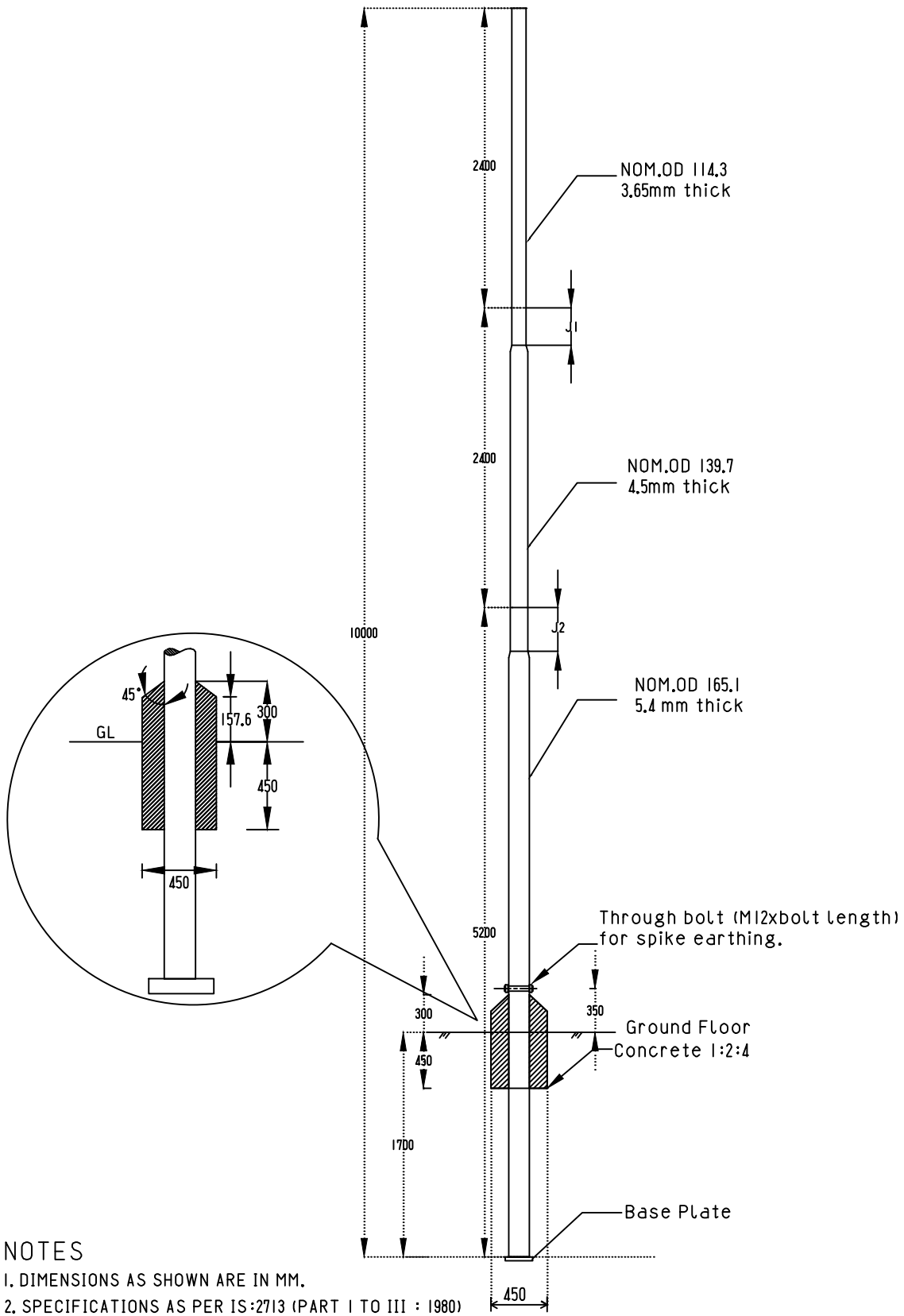

NOTES

1. DIMENSIONS AS SHOWN ARE IN MM.
2. SPECIFICATIONS AS PER IS:2713 (PART I TO III : 1980)
3. POLE TOP CAP -M.S. PLATE WOULD BE TAG WELDED TO THE POLE



BHUTAN POWER CORPORATION LIMITED

ENGINEERING DESIGN & CONTRACTS DEPARTMENT

DISTRIBUTION DESIGN & CONSTRUCTION STANDARD

10 METER SWAGED POLE ASSEMBLY

DESIGNED BY	NAME	DATE
CHECKED BY		
APPROVED BY		

DRAWING NO. BPC-DDCS-2015-20

REVISION
2015

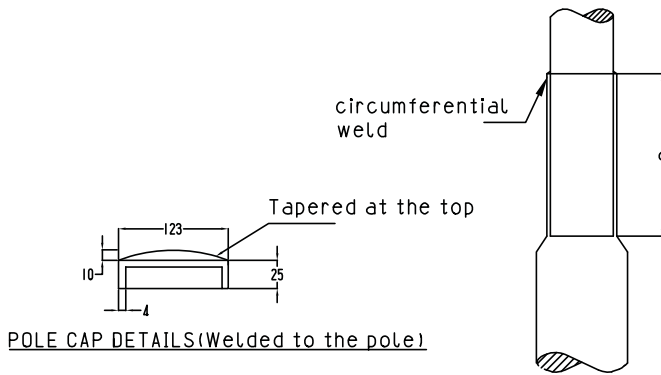

WELDED JOINT J1 DETAILS

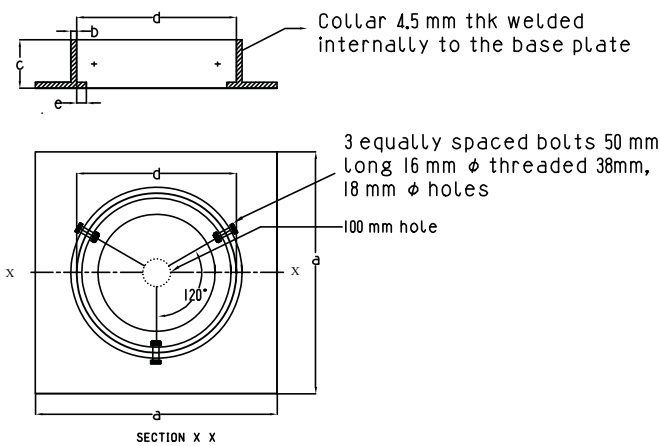
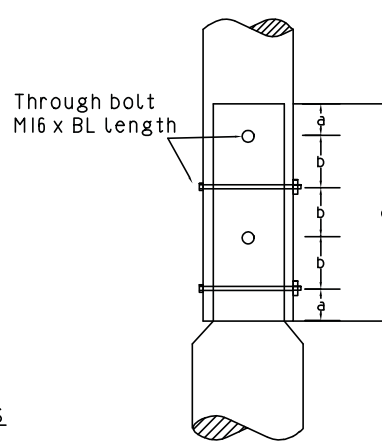

DETAILS OF MS BASE PLATE (Separately packed)

		Pole Type	
			10 M (410-SP-45)
Length		mm	10000
Top Segment	OD	mm	114,3
	Thickness	mm	3,65
	Length	mm	2400
Middle Segment	OD	mm	139,7
	Thickness	mm	4,5
	Length	mm	2400
Bottom Segment	OD	mm	165,1
	Thickness	mm	5,4
	Length	mm	5200
Joint J1	Welded Joint		
	d	mm	300
Joint J2	a	mm	55
	b	mm	80
	c	mm	350
	BL	mm	180
Planting Depth		mm	1700
Base plate details	a	mm	250
	b	mm	6
	c	mm	70
	d	mm	165,1
	e	mm	10

NOTES

1. DIMENSIONS AS SHOWN ARE IN MM.
2. DRAWING NOT TO SCALE.
3. SPECIFICATIONS AS PER IS :2713 (PART I TO III : 1980)
4. POLE TOP CAP -M.S. PLATE WOULD BE TAG WELDED TO THE POLE



BHUTAN POWER CORPORATION LIMITED

ENGINEERING DESIGN & CONTRACTS DEPARTMENT

DISTRIBUTION DESIGN & CONSTRUCTION STANDARD

10 METER SWAGED POLE DETAILS

	NAME	DATE
DESIGNED BY		
CHECKED BY		
APPROVED BY		

DRAWING NO. BPC-DDCS-2015-21

REVISION
2015

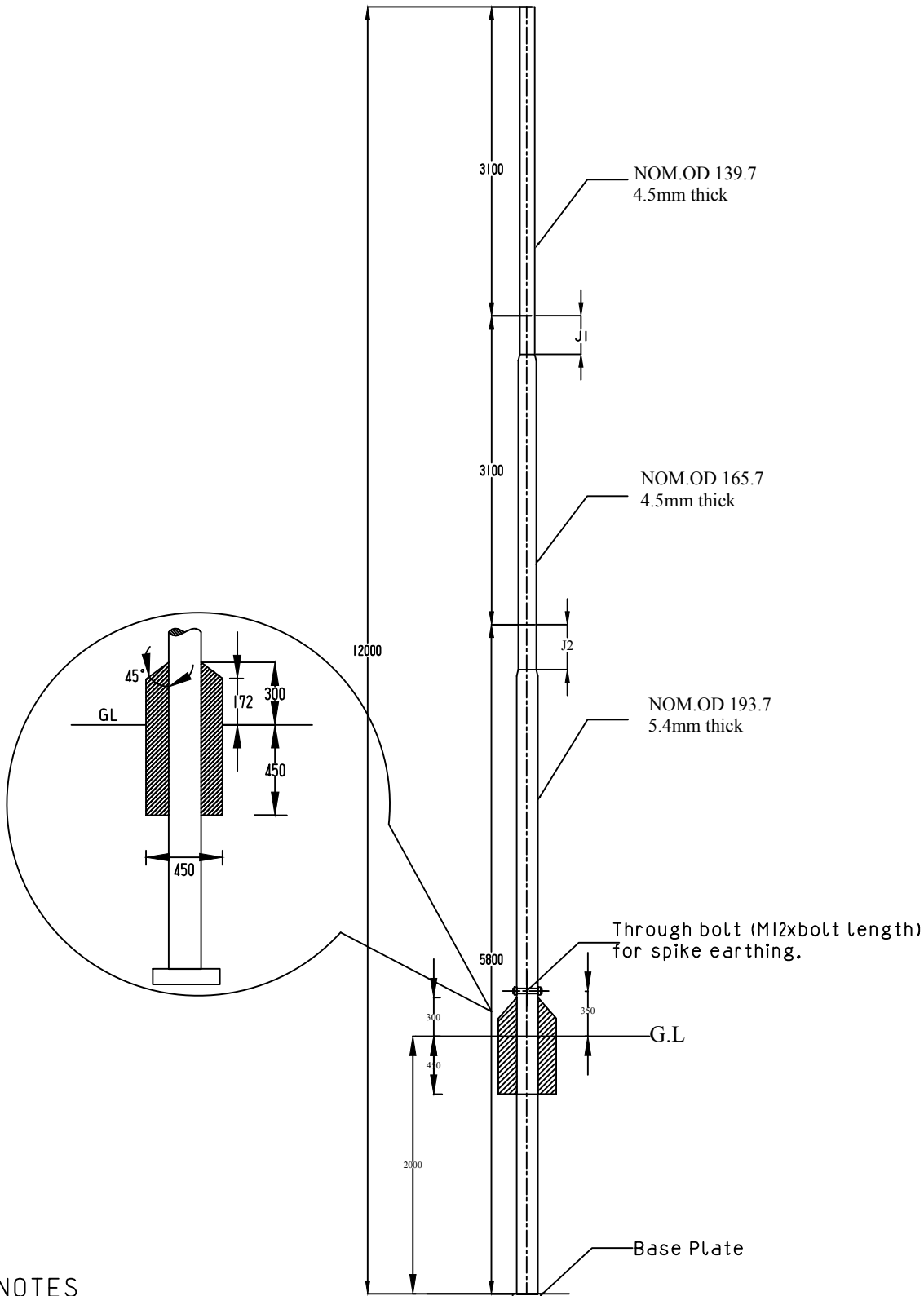

NOTES

1. DIMENSIONS AS SHOWN ARE IN MM.
2. SPECIFICATIONS AS PER IS:2713 (PART I TO III : 1980)
3. POLE TOP CAP -M.S. PLATE WOULD BE TAG WELDED TO THE POLE

	<p style="text-align: center;">BHUTAN POWER CORPORATION LIMITED</p>		ENGINEERING DESIGN & CONTRACTS DEPARTMENT	
			DISTRIBUTION DESIGN AND CONSTRUCTION STANDARD	
DESIGNED BY			12 METERS SWAGED POLE ASSEMBLY	
CHECKED BY			DRAWING NO. BPC-DDCS-2015-22	
APPROVED BY				

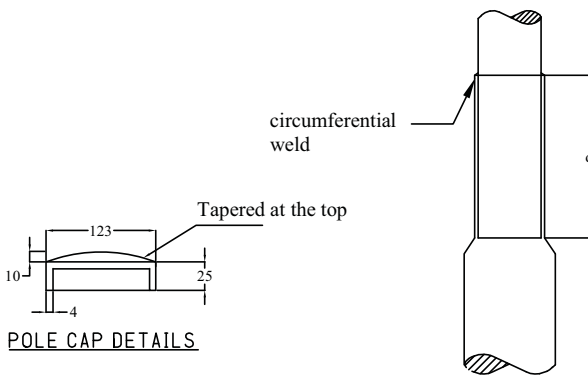

POLE CAP DETAILS

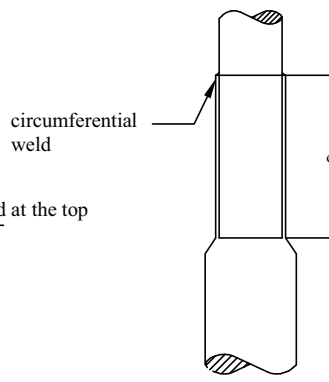

WELDED JOINT J1 DETAILS

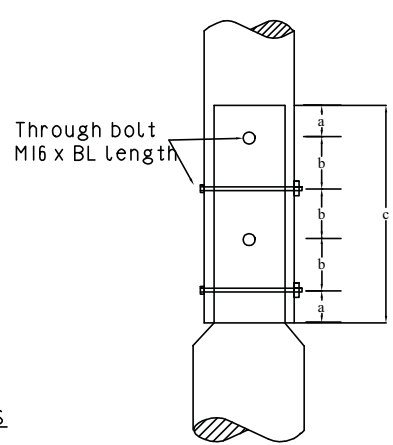

BOLTED JOINT J2 DETAILS

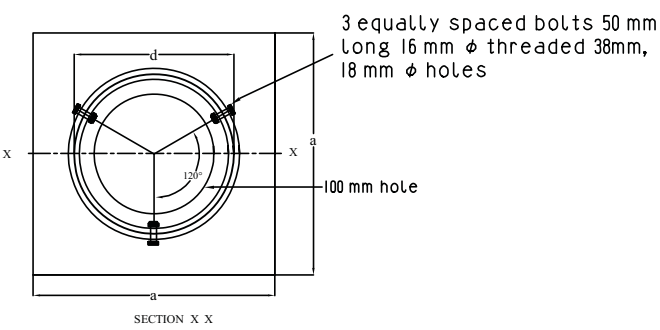
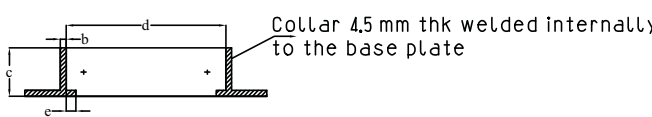

DETAILS OF MS BASE PLATE

Pole Type		12 M (410-SP-62)	
Length		mm	12000
Top Segment	OD	mm	139,7
	Thickness	mm	4,5
	Length	mm	3100
Middle Segment	OD	mm	165,7
	Thickness	mm	4,5
	Length	mm	3100
Bottom Segment	OD	mm	193,7
	Thickness	mm	5,4
	Length	mm	5800
Joint J1	Welded Joint		
	d	mm	300
Joint J2	a	mm	55
	b	mm	80
	c	mm	350
	BL	mm	180
Planting Depth		mm	2000
Base plate details	a	mm	250
	b	mm	6
	c	mm	50
	d	mm	193,7
	e	mm	10
BL for spike earthing		mm	210

NOTES

1. DIMENSIONS AS SHOWN ARE IN MM.
2. DRAWING NOT TO SCALE.
3. SPECIFICATIONS AS PER IS:2713 (PART I TO III : 1980)
4. POLE TOP CAP -M.S. PLATE WOULD BE TAG WELDED TO THE POLE



BHUTAN POWER CORPORATION LIMITED

ENGINEERING DESIGN & CONTRACTS DEPARTMENT

DISTRIBUTION DESIGN AND CONSTRUCTION STANDARD

12 METERS SWAGED POLE ASSEMBLY DETAILS

	NAME	DATE
DESIGNED BY		
CHECKED BY		
APPROVED BY		

DRAWING NO. BPC-DDCS-2015-23

REVISION
2015

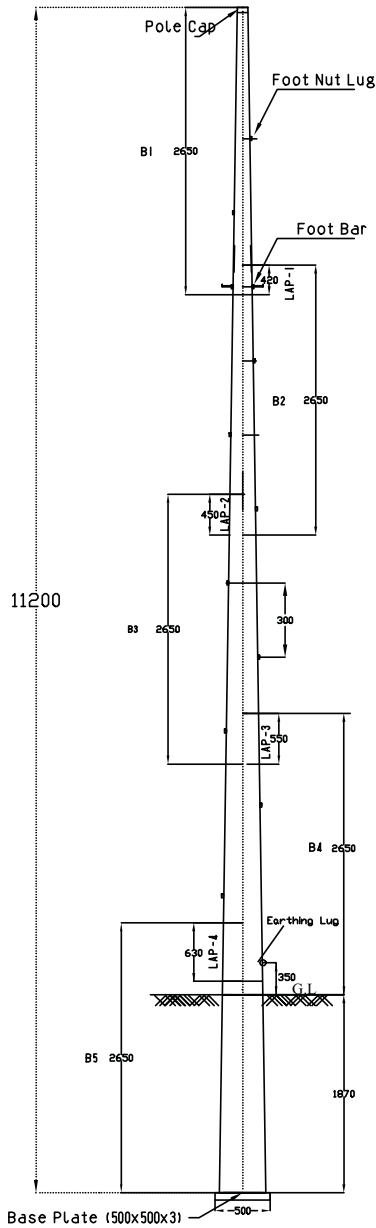

PARAMETERS					
SECTION	B1	B2	B3	B4	B5
LENGTH(mm)	2650	2650	2650	2650	2650
THICKNESS(mm)	2.1	2.1	2.1	2.1	2.1
TOP DIAMETER(mm)	119	180	240	298	352
BOTTOM DIAMETER(mm)	197	258	318	375	430

OVERLAPS				
OVERLAPS	LAP-1 B1/B2	LAP-2 B2/B3	LAP-3 B3/B4	LAP-4 B4/B5
OVERLAPS	420	450	550	630

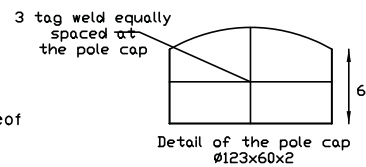
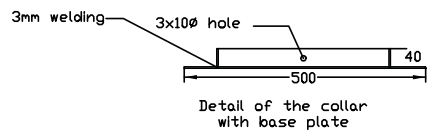
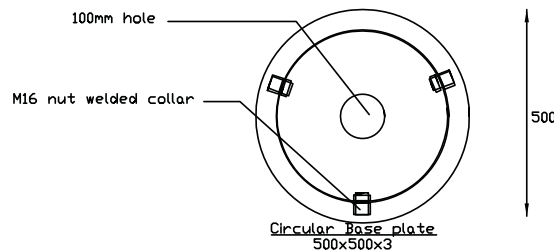
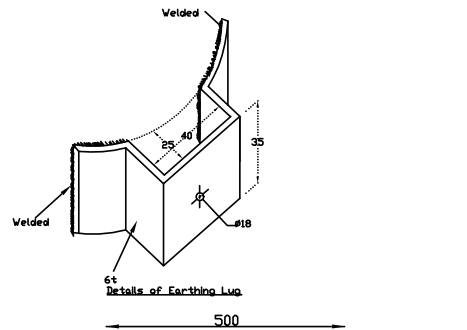

Note:
 *All Parts shall be BS 4360: 1986 Grade 50 C and Galvanization as per IS 2629-1985 or BS 729-1971 or Equivalent National or International Standards and any revision thereof
 *All Dimensions in mm
 *Footing bar distance to be maintained at 300mm



BHUTAN POWER CORPORATION LIMITED

ENGINEERING DESIGN & CONTRACTS DEPARTMENT

TITLE : DISTRIBUTION DESIGN & CONSTRUCTION STANDARD

TELESCOPIC POLE DETAILS FOR 11.2M

DESIGNATION	NAME	DATE
DRAFTSMAN		
DESIGNER		
DESIGN CHECK		
PROJECT MANAGER		
PROJECT DIRECTOR		

DRAWING NO. BPC-DDCS-2015-24

REVISION
2015

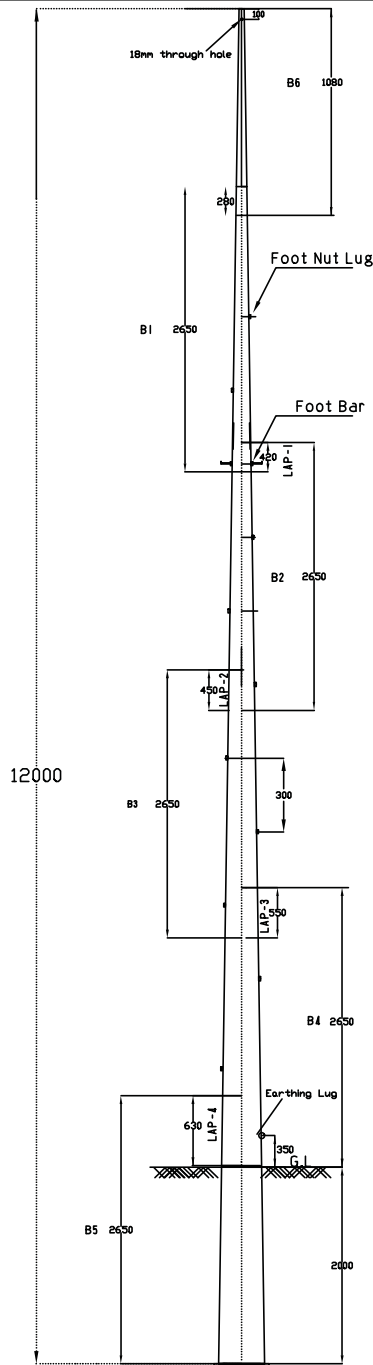

PARAMETERS						
SECTION	B1	B2	B3	B4	B5	B6
LENGTH(mm)	2650	2650	2650	2650	2650	1080
THICKNESS(mm)	2.1	2.1	2.1	2.1	2.1	2.1
TOP DIAMETER(mm)	119	180	240	298	352	100
BOTTOM DIAMETER(mm)	197	258	318	375	430	132

OVERLAPS					
OVERLAPS	LAP-1 B1/B2	LAP-2 B2/B3	LAP-3 B3/B4	LAP-4 B4/B5	LAP-5 B6/B1
OVERLAPS	420	450	550	630	280

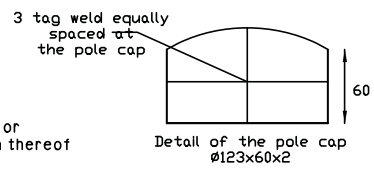
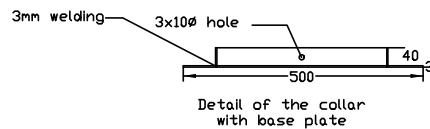
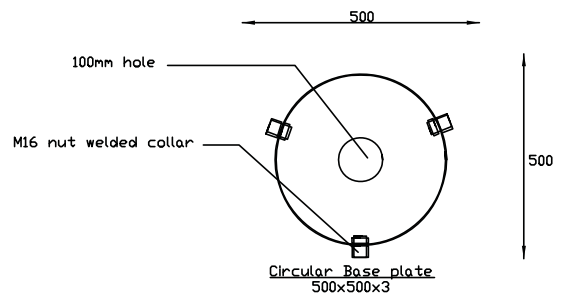
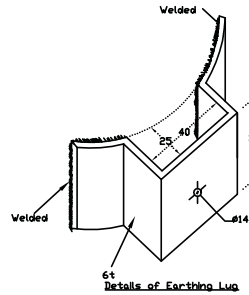

Note:

- *All Parts shall be BS 4360: 1986 Grade 50 C and Galvanization as per IS 2629-1985 or BS 729-1971 or Equivalent National or International Standards and any revision thereof
- *All Dimensions in mm
- * Through hole dia 18mm at 100mm from the pole top for shielding wire
- * Footing bar distance to be maintained at 300mm

BHUTAN POWER CORPORATION LIMITED

DESIGNATION	NAME	DATE
DRAFTSMAN		
DESIGNER		
DESIGN CHECK		
PROJECT MANAGER		
PROJECT DIRECTOR		

ENGINEERING DESIGN & CONTRACTS DEPARTMENT

TITLE : DISTRIBUTION DESIGN & CONSTRUCTION STANDARD

TELESCOPIC POLE DETAILS FOR 12M

DRAWING NO.BPC -DDCS -2015-25	REVISION 2015
-------------------------------	------------------

Details of Footbar

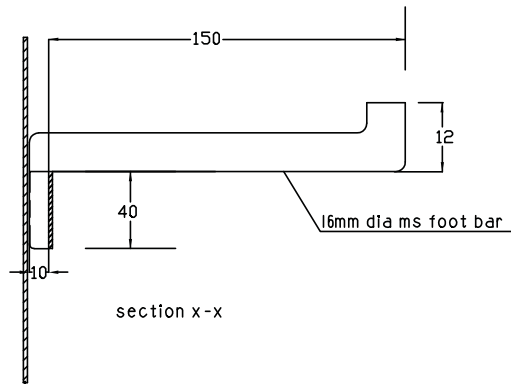
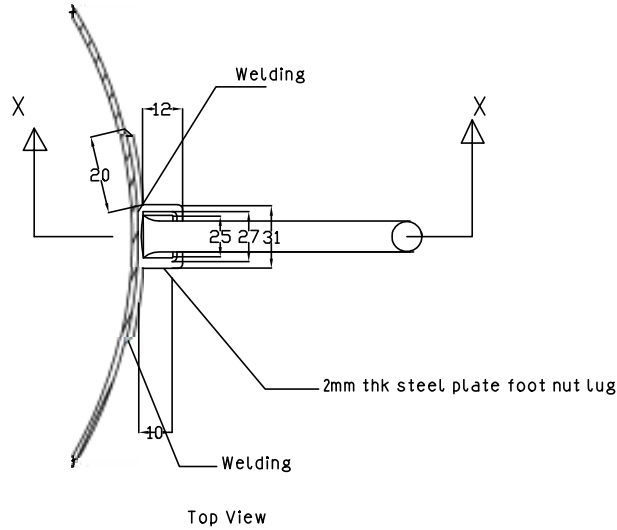

NOTES

1. FERROUS PARTS HOT DIP GALVANIZED AS PER BS-729
2. DIMENSIONS AS SHOWN ARE IN mm.
3. TOLERANCE $\pm 5\%$
4. DRAWING IS NOT TO SCALE.
5. FOUR NUMBERS PER POLE



BHUTAN POWER CORPORATION LIMITED

ENGINEERING DESIGN & CONTRACTS DEPARTMENT

DISTRIBUTION DESIGN & CONSTRUCTION STANDARD

Foot Bar for Telescopic Pole

DESIGNATION	NAME	DATE
DRAFTSMAN		
DESIGNER		
DESIGN CHECK		
PROJECT MANAGER		
PROJECT DIRECTOR		

DRAWING NO. BPC-DDCS-2015-26

REVISION
2015

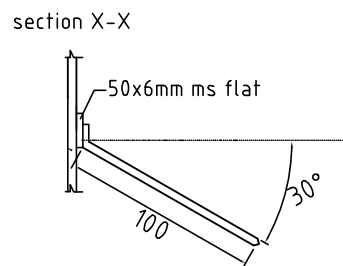
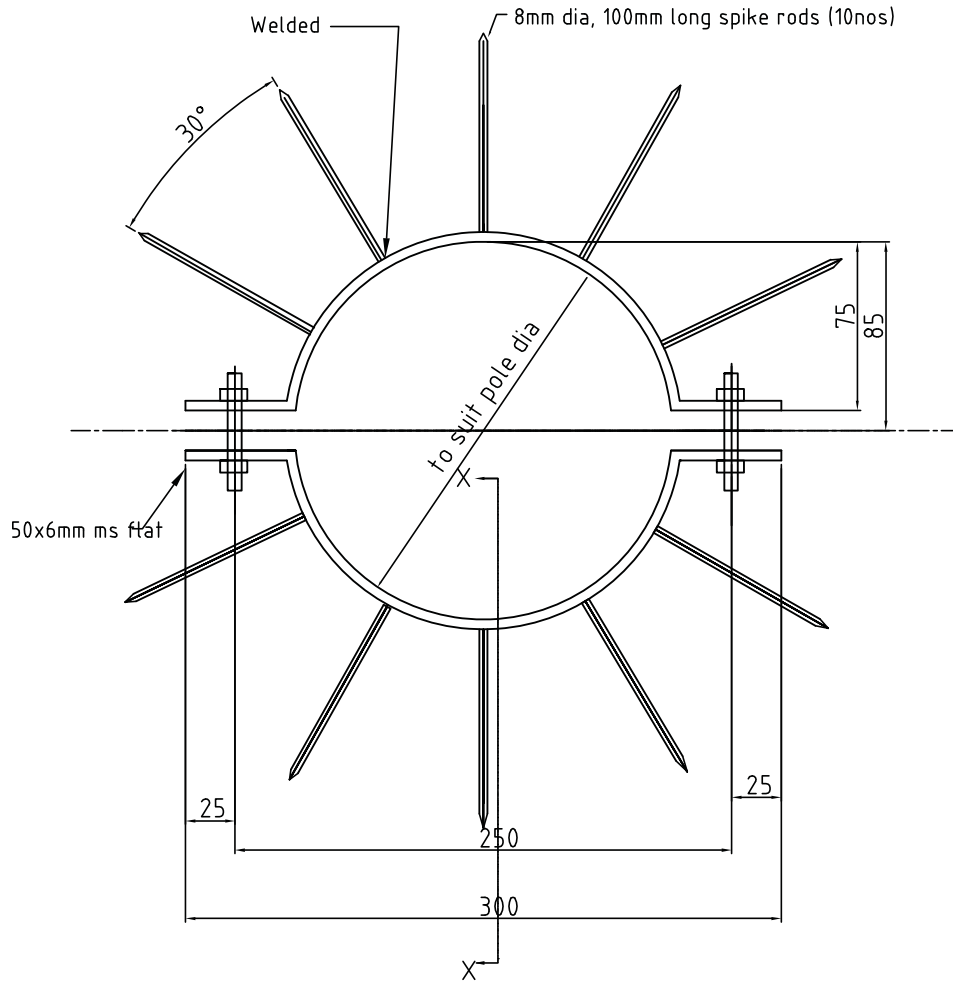

NOTES

1. FERROUS PARTS HOT DIP GALVANIZED AS PER BS-729
2. DIMENSIONS AS SHOWN ARE IN mm.
3. TOLERANCE $\pm 5\%$
4. DRAWING IS NOT TO SCALE.
5. ONE NUMBER PER POLE

	BHUTAN POWER CORPORATION LIMITED		ENGINEERING DESIGN & CONTRACTS DEPARTMENT	
			DISTRIBUTION DESIGN & CONSTRUCTION STANDARD	
		ANTI-CLIMBING DEVICE		
DESIGNATION	NAME	DATE		
DRAFTSMAN				
DESIGNER				
DESIGN CHECK				
PROJECT MANAGER			DRAWING NO. BPC-DDCS-2015-27	
PROJECT DIRECTOR				
			REVISION 2015	

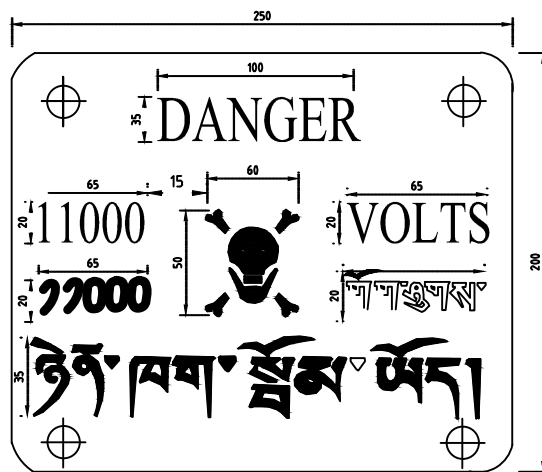
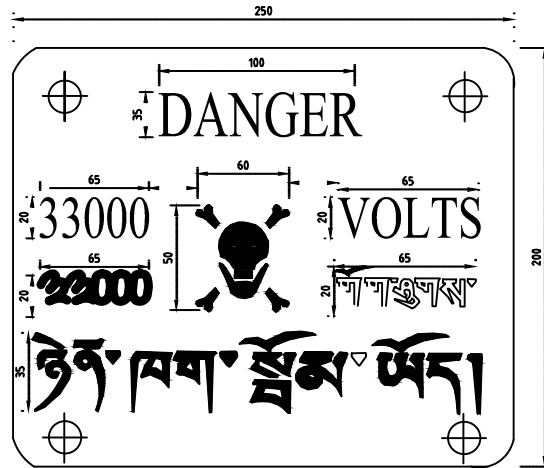

1. DIMENSIONS AS SHOWN ARE IN MM
2. MS PLATE SHALL BE 2MM THICK
3. LETTERING AND FIGURE: RED ENAMELED
BACK GROUND: WHITE ENAMELED
BACK OF THE PLATE: BLACK ENAMELED
4. DESIGN OF DANGER PLATE IS AS PER IS:2551
5. CORNERS OF THE PLATE SHALL BE ROUND OFF
6. FASTERNERS PER PLATE: 4 NOS. 16MM DIA WITH GI BOLTS
7. ONE DANGER PLATE PER STRUCTURE

	BHUTAN POWER CORPORATION LIMITED		ENGINEERING DESIGN & CONTRACTS DEPARTMENT	
			DISTRIBUTION DESIGN & CONSTRUCTION STANDARD	
DESIGNATION			DANGER PLATE FOR 33kV and 11KV POLE	
NAME			DRAWING NO. BPC -DDCS -2015-28	
DATE				
DRAFTSMAN				
DESIGNER				
DESIGN CHECK				
PROJECT MANAGER			REVISION 2015	
PROJECT DIRECTOR				

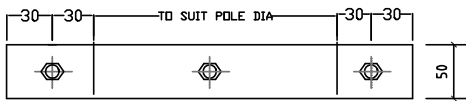
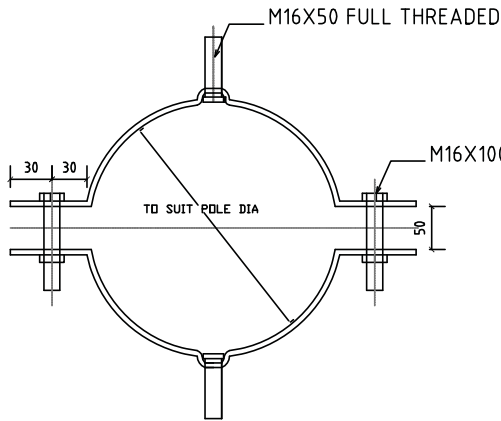

Y TYPE - CLAMP (FULL CLAMP)

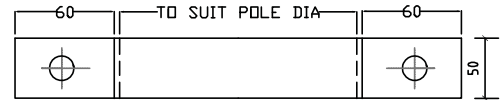
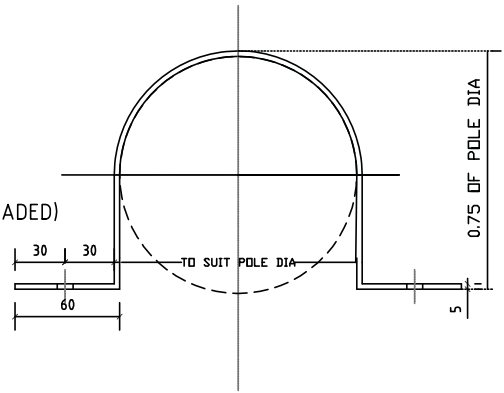

X TYPE - CLAMP (HALF CLAMP)

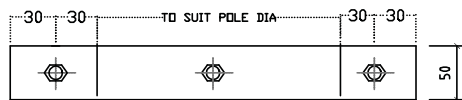
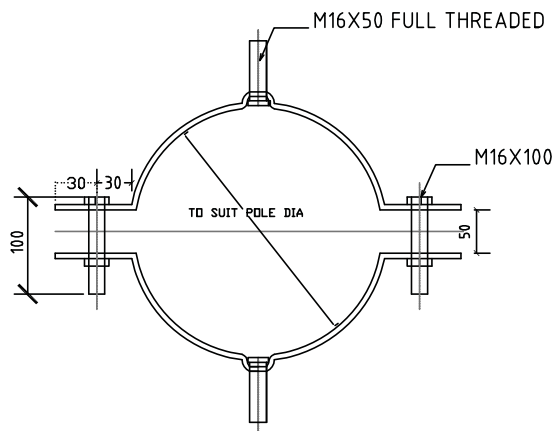

STAY CLAMP

NOTES

1. DIMENSIONS AS SHOWN ARE IN mm.
2. DRAWING IS NOT TO SCALE.
3. ALL MATERIALS SHALL BE GALVANIZED
4. ALL THE BOLTS SHALL BE FULL THREADED TYPE

	BHUTAN POWER CORPORATION LIMITED		ENGINEERING DESIGN & CONTRACTS DEPARTMENT			
			DISTRIBUTION DESIGN & CONSTRUCTION STANDARD			
CLAMPS FOR TELESCOPIC POLE			DRAWING NO. BPC-DDCS-2015-29			
DESIGNATION	NAME	DATE			REVISION 2015	
DRAFTSMAN						
DESIGNER						
DESIGN CHECK						
PROJECT MANAGER						
PROJECT DIRECTOR						

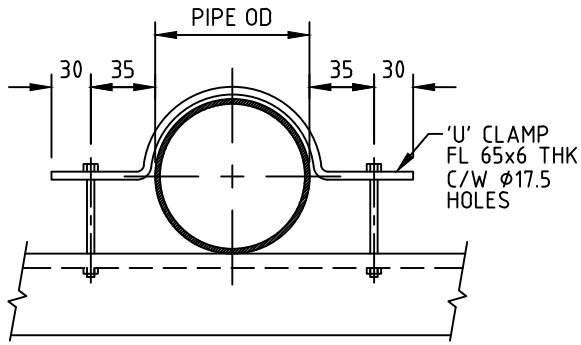

1 'U' CLAMP

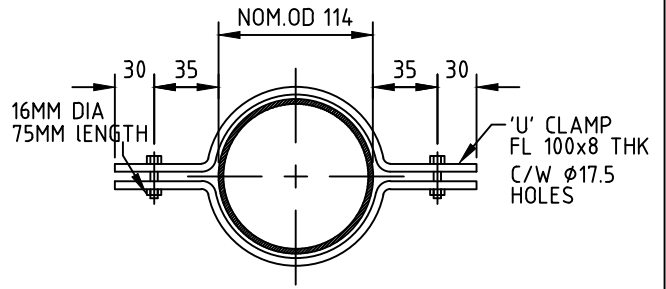

4 STAY CLAMP

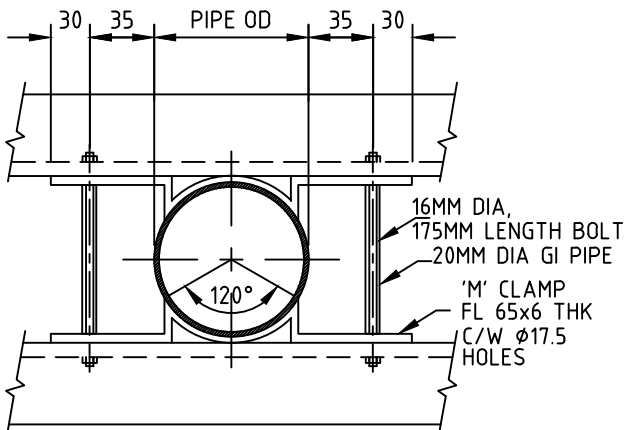

2 'M' CLAMP

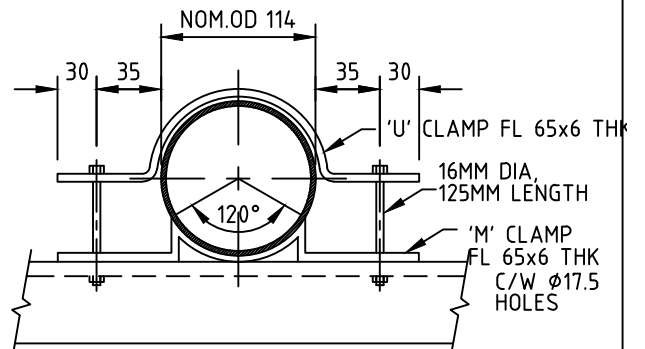

5 CROSS ARM CLAMP (U+M)

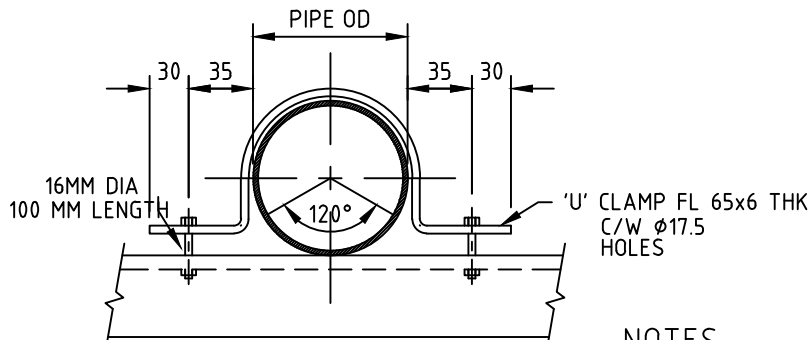

3 FULL CLAMP

NOTES

1. DIMENSIONS AS SHOWN ARE IN mm.
2. DRAWING IS NOT TO SCALE.
3. ALL BOLTS TO BE Ø16 C/W NUTS & SPRING WASHERS.



BHUTAN POWER CORPORATION LIMITED

ENGINEERING DESIGN & CONTRACTS DEPARTMENT

TITLE : DISTRIBUTION DESIGN & CONSTRUCTION STANDARD

33 & 11 KV CLAMP DETAILS FOR STEEL TUBULAR POLE

DESIGNATION	NAME	DATE
DRAFTSMAN		
DESIGNER		
DESIGN CHECK		
PROJECT MANAGER		
PROJECT DIRECTOR		

DRAWING NO. BPC-DDCS-2015-30

REVISION 2015

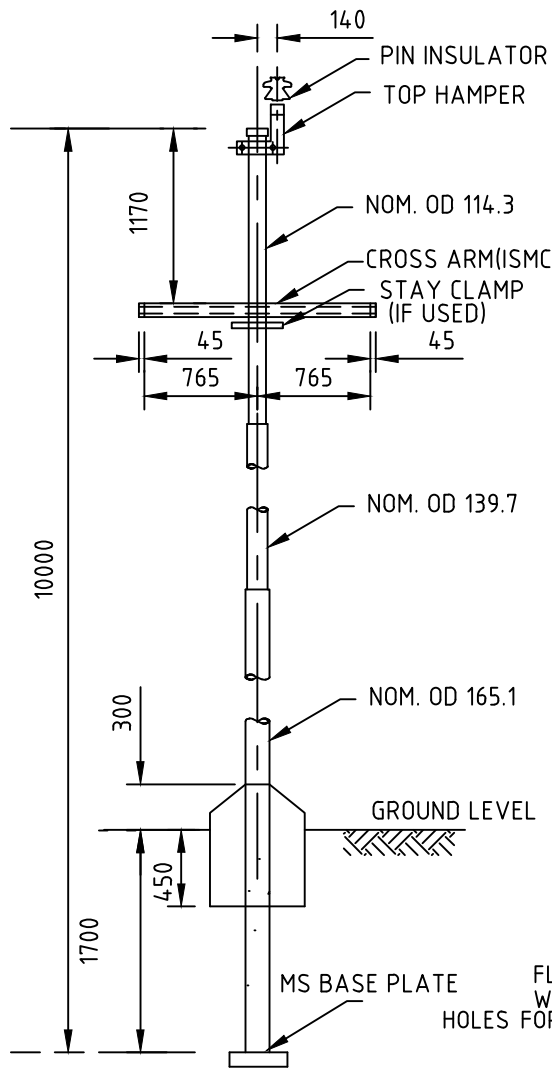

POLE & CROSS ARM ASSEMBLY

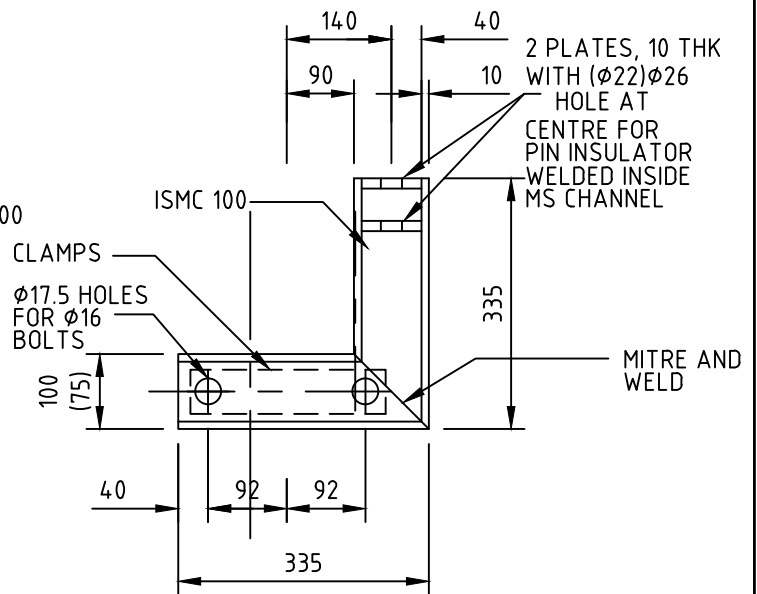

TOP HAMPER FOR INSULATOR PIN DETAIL

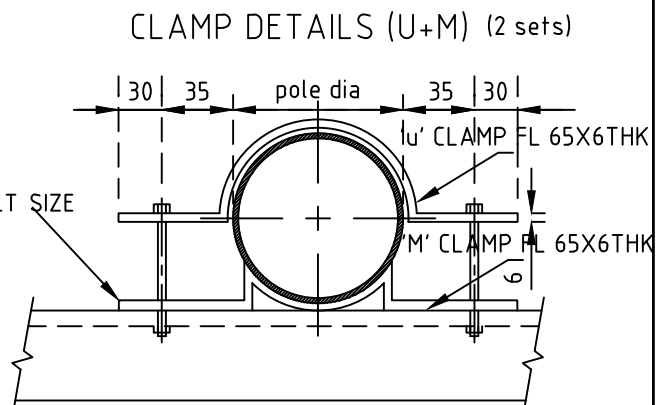

CLAMP DETAILS (U+M) (2 sets)

NOTES

1. DIMENSIONS AS SHOWN ARE IN mm
2. DRAWING IS NOT TO SCALE.
3. ALL NUTS AND BOLTS TO BE HOT DIPPED GALVANISED

10M STEEL TUBULAR POLE	1	STEEL
CROSSARM CHANNEL	1	MS
TOP HAMPER WELDED IN "L" SHAPE	1	MS
PIN INSULATOR	3	PORCELAIN
CLAMP WITH NUTS & BOLTS (U+M)	2	MS
STAY SET ASSEMBLY	1	MS
BASE PLATE	1	MS
DESCRIPTION	QTY	MATERIAL



BHUTAN POWER CORPORATION LIMITED

ENGINEERING DESIGN & CONTRACTS DEPARTMENT

DISTRIBUTION DESIGN & CONSTRUCTION STANDARD

STEEL TUBULAR - SINGLE POLE STRUCTURE DETAILS
11 & 33 kV

DESIGNATION	NAME	DATE
DRAFTSMAN		
DESIGNER		
DESIGN CHECK		
PROJECT MANAGER		
PROJECT DIRECTOR		

DRAWING NO. BPC-DDCS-2015-31

REVISION
2015

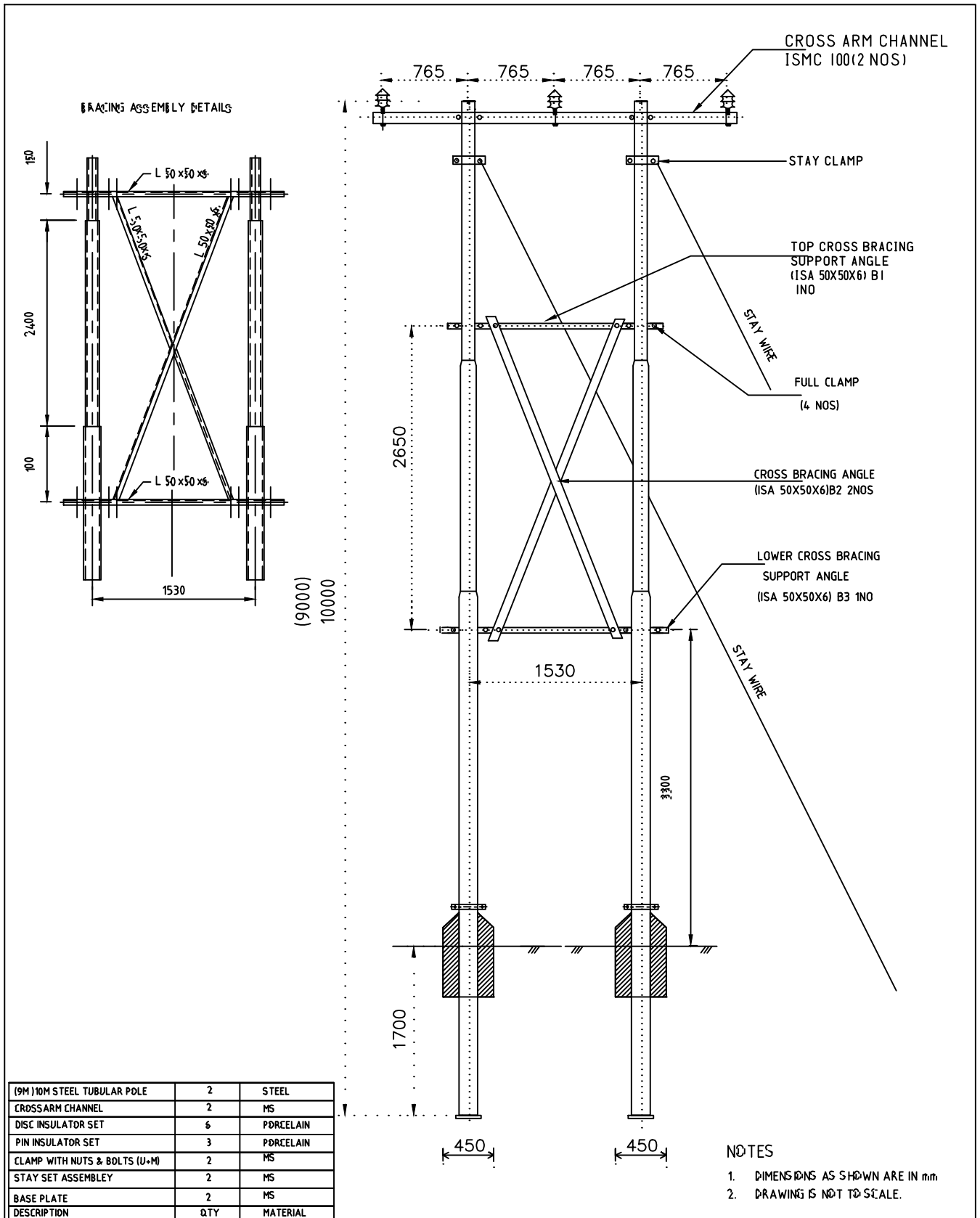

BRACING ASSEMBLY DETAILS

(9M) 10M STEEL TUBULAR POLE	2	STEEL
CROSS ARM CHANNEL	2	MS
DISC INSULATOR SET	6	PORCELAIN
PIN INSULATOR SET	3	PORCELAIN
CLAMP WITH NUTS & BOLTS (U+M)	2	MS
STAY SET ASSEMBLY	2	MS
BASE PLATE	2	MS
DESCRIPTION	QTY	MATERIAL

- NOTES
1. DIMENSIONS AS SHOWN ARE IN mm
 2. DRAWING IS NOT TO SCALE.



BHUTAN POWER CORPORATION LIMITED

ENGINEERING DESIGN & CONTRACTS DEPARTMENT

DISTRIBUTION DESIGN & CONSTRUCTION STANDARD

11 & 33 KV H-FRAME

DOUBLE POLE ARRANGEMENT (STEEL TUBULAR POLES)

DESIGNATION	NAME	DATE
DRAFTSMAN		
DESIGNER		
DESIGN CHECK		
PROJECT MANAGER		
PROJECT DIRECTOR		

DRAWING NO. BPC-DDCS-2015-32/1

REVISION 2015

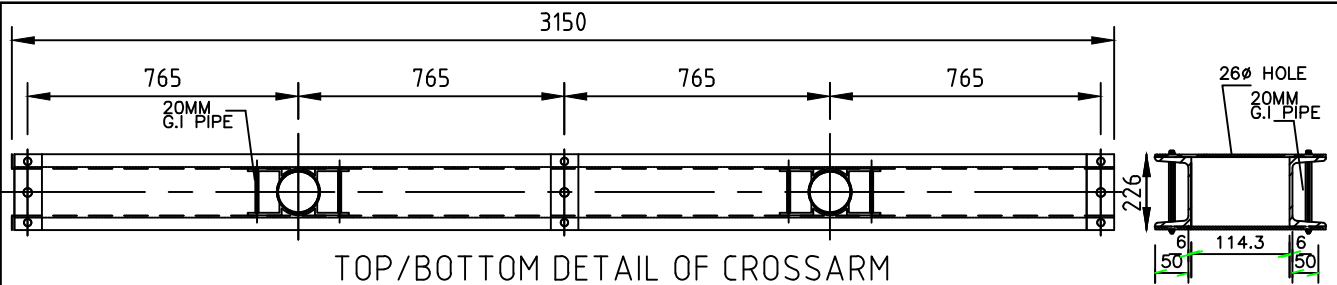

TOP/BOTTOM DETAIL OF CROSSARM

ISM 100x50 (2NOS)

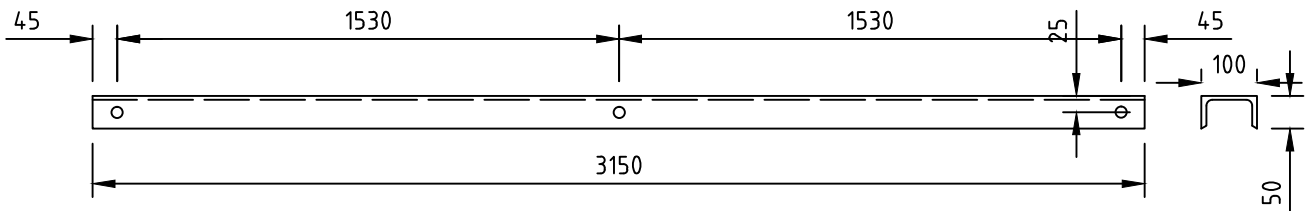

TOP VIEW OF CROSSARM - CHL

ISM 100x50 (2 NOS)

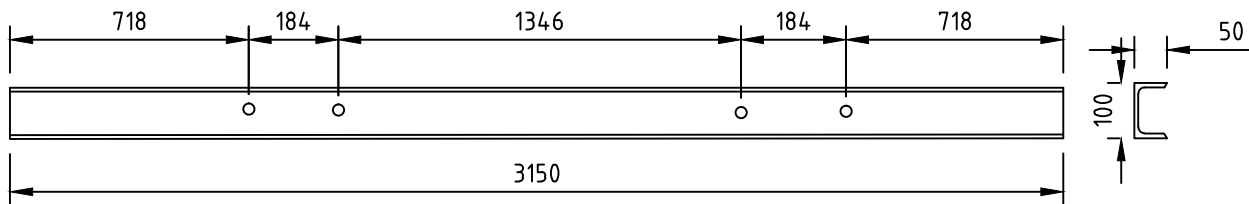

FRONT VIEW OF CROSSARM - CHL

ISM 100x50 (2 NOS)

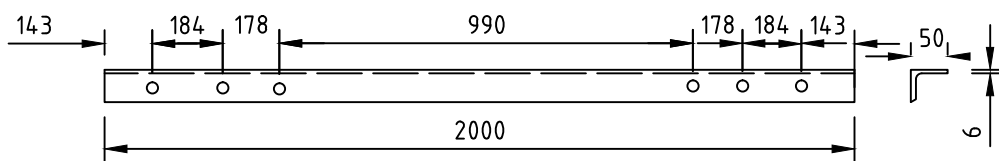

DETAIL OF BRACING - B1

ISA 50x50x6 (1 NO)

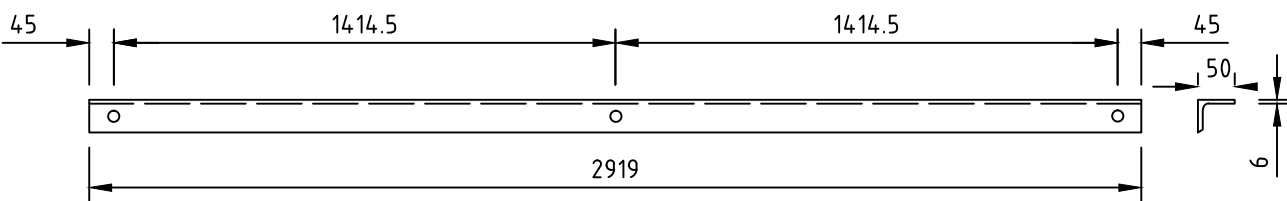

DETAIL OF BRACING - B2

ISA 50x50x6 (2 NOS)

NOTES

1. DIMENSIONS AS SHOWN ARE IN mm.
2. DRAWING IS NOT TO SCALE.
3. ALL BOLT HOLES TO BE 18MM EXCEPT FOR THE ONE INDICATED.



BHUTAN POWER CORPORATION LIMITED

ENGINEERING DESIGN & CONTRACTS DEPARTMENT

DISTRIBUTION DESIGN & CONSTRUCTION STANDARD

11 & 33 KV H-FRAME

CHANNEL & BRACING DETAIL (STEEL TUBULAR POLES)

DESIGNATION	NAME	DATE
DRAFTSMAN		
DESIGNER		
DESIGN CHECK		
PROJECT MANAGER		
PROJECT DIRECTOR		

DRAWING NO. BPC-DDCS-2015-32/2

REVISION
2015

DETAIL OF BRACING - B3

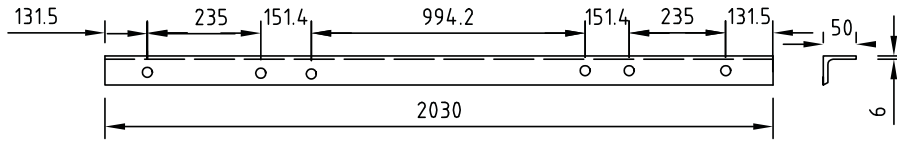

ISA 50x50x6 (1 NO)

DETAIL OF MS STRING LACING FLAT

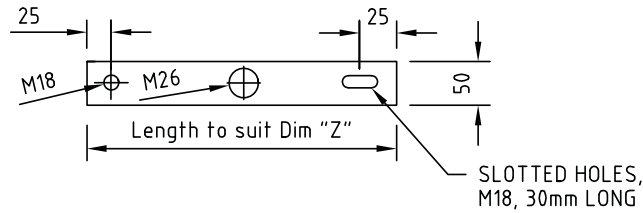

FL 50x6 (6 NOS)

GI 16MM DIA NUTS AND BOLTS (6NOS)

FIXING OF PIN AND DISC INSULATOR ON CROSSARM

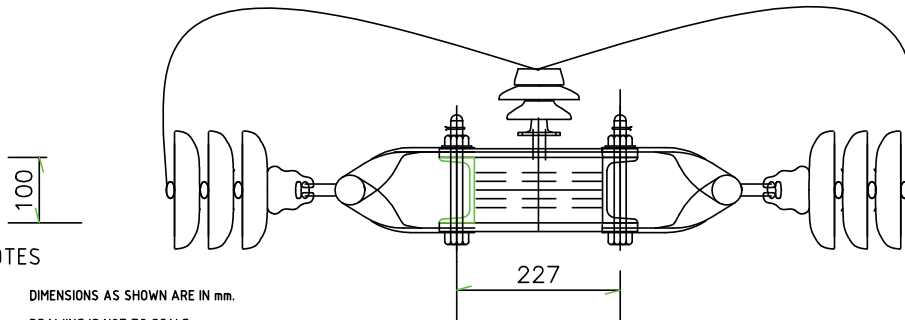

NOTES

- DIMENSIONS AS SHOWN ARE IN mm.
- DRAWING IS NOT TO SCALE.
- STANDARDS
 - IS 2062-1992/IS 1161 OR EQUIVALENT STEEL FOR GENERAL STRUCTURAL PURPOSES
 - IS 808-1964: OR EQUIVALENT DIMENSIONS FOR HOT ROLLED STEEL BEAM COLUMN CHANNEL AND ANGLE SECTION
- MINIMUM TENSILE STRENGTH - 420 MPA
- ALL ITEMS SHALL BE MILD STEEL (MS) PAINTED WITH ONE COAT OF RED OXIDE PRIMER IN ACCORDANCE WITH ISO 12944-7 OR ANY OTHER EQUIVALENT INTERNATIONAL STANDARD. HOWEVER, NUTS AND BOLTS SHALL BE HOT DIPPED GALVANISED WITH ZINC COATING 600 GRAM PER SQUARE METER.
- DISC ARRANGEMENT IS SHOWN FOR 33kV SYSTEM, TAKE ONE DISC INSULATOR FOR 11kV SYSTEM

 <p>BHUTAN POWER CORPORATION LIMITED</p>	ENGINEERING DESIGN & CONTRACTS DEPARTMENT	
	DISTRIBUTION DESIGN & CONSTRUCTION STANDARD	
	11 & 33 KV H-FRAME	
	CHANNEL & BRACING DETAIL (STEEL TUBULAR POLES)	
DESIGNATION	NAME	DATE
DRAFTSMAN		
DESIGNER		
DESIGN CHECK		
PROJECT MANAGER		
PROJECT DIRECTOR		
DRAWING NO. BPC-DDCS-2015-32/3		REVISION 2015

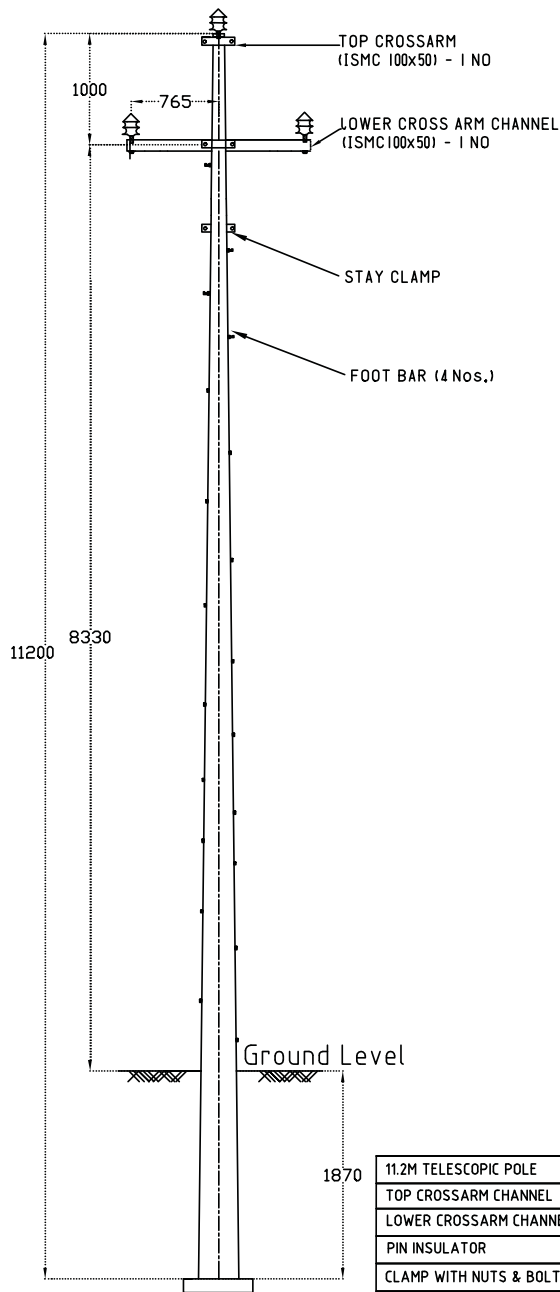

NOTES

1. DIMENSIONS AS SHOWN ARE IN mm.
2. DRAWING IS NOT TO SCALE.

DESCRIPTION	QTY	MATERIAL
11.2M TELESCOPIC POLE	1	GS
TOP CROSSARM CHANNEL	1	GS
LOWER CROSSARM CHANNEL	1	GS
PIN INSULATOR	3	PORCELAIN
CLAMP WITH NUTS & BOLTS	2	GS
STAY SET ASSEMBLY	1	GS
BASE PLATE	1	GS

	BHUTAN POWER CORPORATION LIMITED		ENGINEERING DESIGN & CONTRACTS DEPARTMENT	
			DISTRIBUTION DESIGN & CONSTRUCTION STANDARD SINGLE POLE ASSEMBLY - 11.2 M TELESCOPIC POLE (11 kV & 33kV)	
DESIGNATION	NAME	DATE	DRAWING NO. BPC-DDCS-2015-33/1	REVISION 2015
DRAFTSMAN				
DESIGNER				
DESIGN CHECK				
PROJECT MANAGER				
PROJECT DIRECTOR				

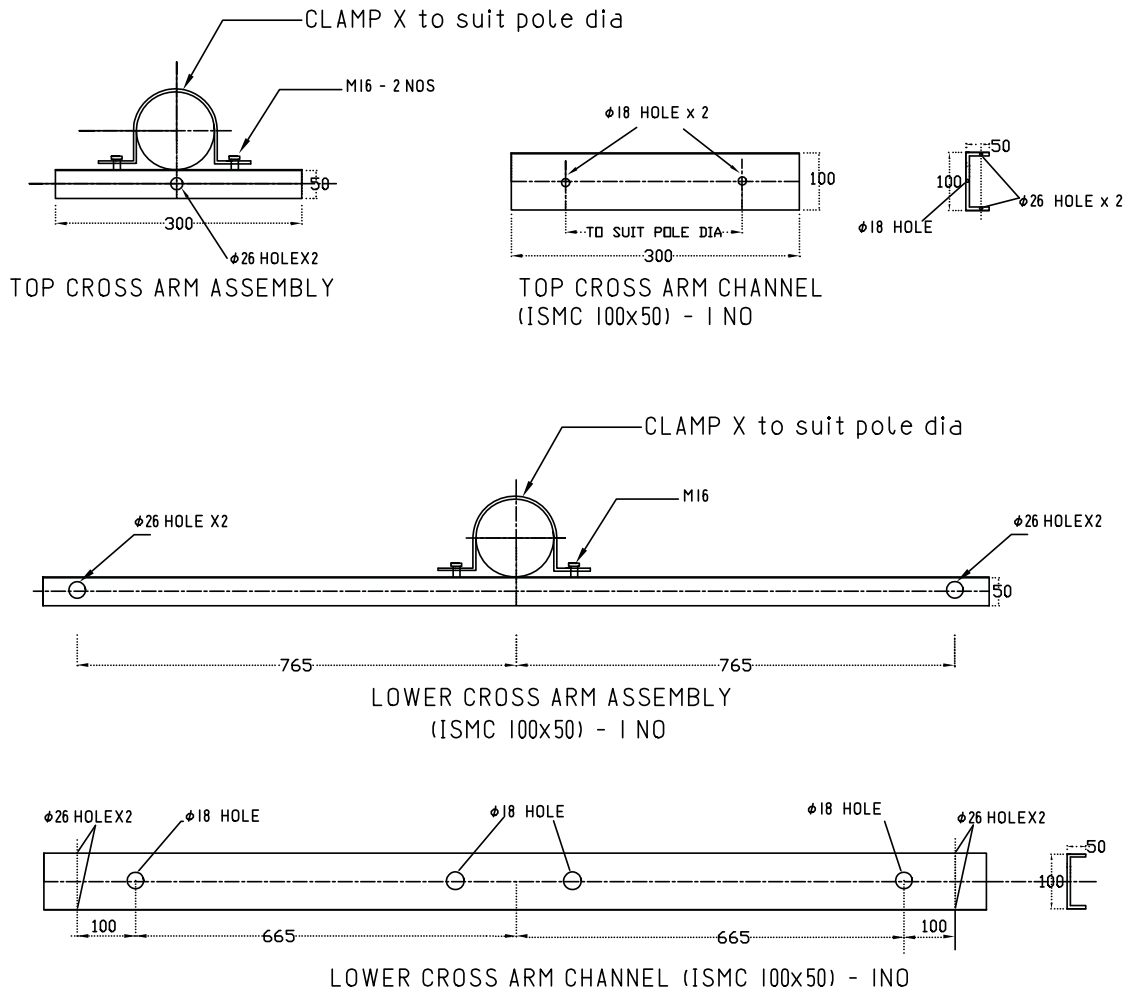

NOTES

1. DIMENSIONS AS SHOWN ARE IN mm.
2. DRAWING IS NOT TO SCALE.
3. LENGTH OF THE BRACING ANGLE SHALL BE DESIGNED BY THE SUPPLIER

	BHUTAN POWER CORPORATION LIMITED		ENGINEERING DESIGN & CONTRACTS DEPARTMENT	
			DISTRIBUTION DESIGN & CONSTRUCTION STANDARD	
		SINGLE POLE CROSS ARM ASSEMBLY - 11.2M TELESCOPIC POLE (11 kV & 33kV)		
DESIGNATION	NAME	DATE	DRAWING NO. BPC-DDCS-2015-33/2	
DRAFTSMAN				
DESIGNER				
DESIGN CHECK				
PROJECT MANAGER				
PROJECT DIRECTOR				
			REVISION 2015	

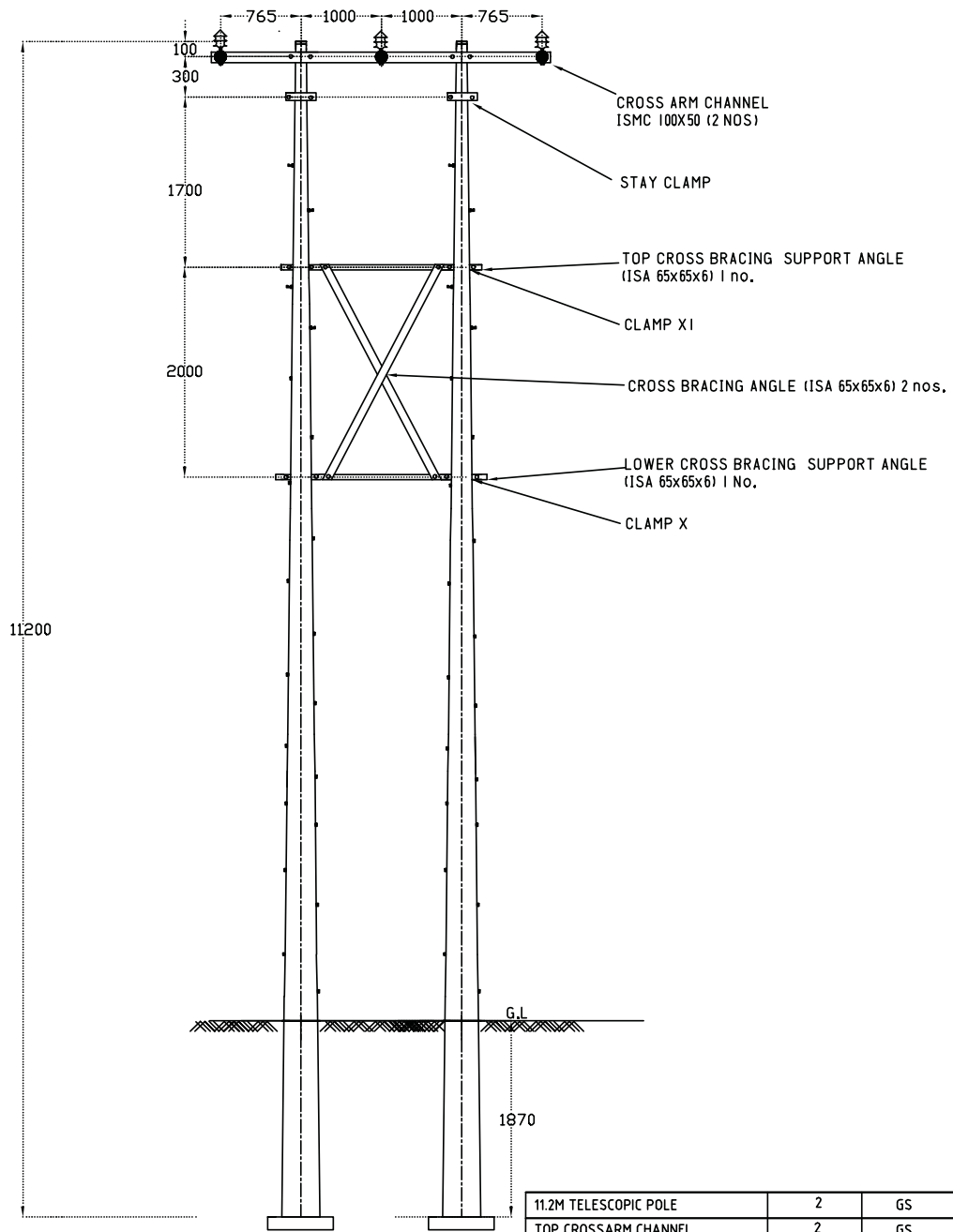

NOTES

1. DIMENSIONS AS SHOWN ARE IN mm.
2. DRAWING IS NOT TO SCALE.

11.2M TELESCOPIC POLE	2	GS
TOP CROSSARM CHANNEL	2	GS
DISC INSULATOR SET	6	PORCELAIN
PIN INSULATOR	3	PORCELAIN
CLAMP WITH NUTS & BOLTS	2	GS
STAY SET ASSEMBLY	1	GS
BASE PLATE	1	GS
DESCRIPTION	QTY	MATERIAL

	BHUTAN POWER CORPORATION LIMITED	ENGINEERING DESIGN & CONTRACTS DEPARTMENT	
		DISTRIBUTION DESIGN & CONSTRUCTION STANDARD	
DOUBLE POLE ASSEMBLY - 11.2 M TELESCOPIC POLE (11 kV & 33kV)			
DESIGNATION	NAME	DATE	DRAWING NO. BPC-DDCS-2015-34/1
DRAFTSMAN			
DESIGNER			
DESIGN CHECK			
PROJECT MANAGER			
PROJECT DIRECTOR			
			REVISION 2015

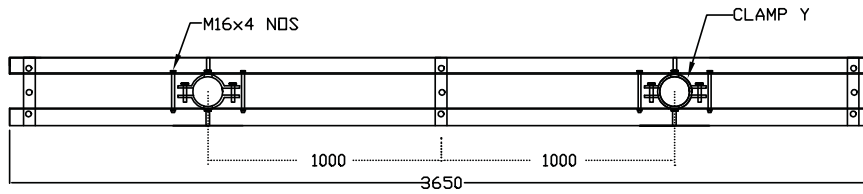

CROSS ARM ASSEMBLY PLAN

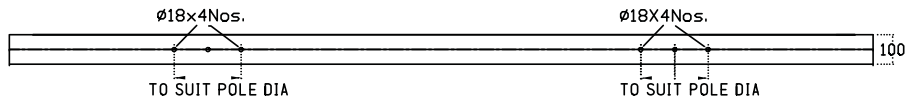

CROSS ARM CHANNEL (ISMC 100x50) - ELEVATION

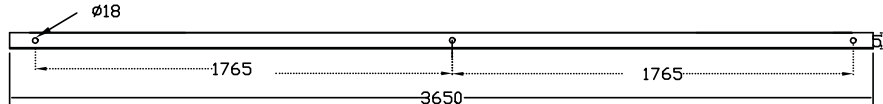

CROSS ARM CHANNEL (ISMC 100x50) - PLAN

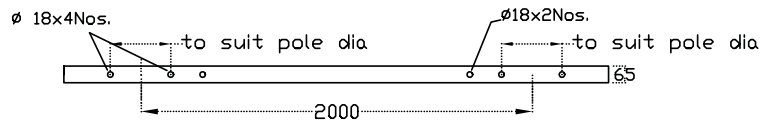

ANGLE FOR TOP CROSS BRACING SUPPORT (ISA 65x40x6) - 1 NO

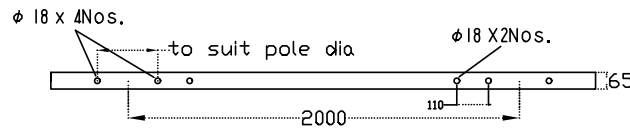

ANGLE FOR LOWER CROSS BRACING SUPPORT (ISA 65x65x6) - 1 NO



ANGLE FOR CROSS BRACING (ISA 65 x 65 x 6) - 2 NOS

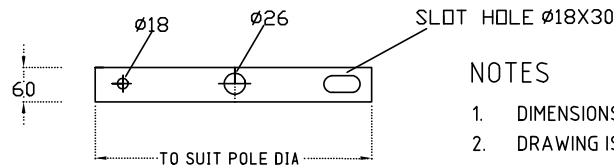

MS TENSION STRAP (60x6) - 6 NOS

NOTES

1. DIMENSIONS AS SHOWN ARE IN mm.
2. DRAWING IS NOT TO SCALE.
3. LENGTH OF THE CROSS BRACING ANGLE SHALL BE DESIGNED BY THE SUPPLIER

 <p>BHUTAN POWER CORPORATION LIMITED</p>		ENGINEERING DESIGN & CONTRACTS DEPARTMENT																			
		DISTRIBUTION DESIGN & CONSTRUCTION STANDARD																			
<table border="1"> <thead> <tr> <th>DESIGNATION</th> <th>NAME</th> <th>DATE</th> </tr> </thead> <tbody> <tr> <td>DRAFTSMAN</td> <td></td> <td></td> </tr> <tr> <td>DESIGNER</td> <td></td> <td></td> </tr> <tr> <td>DESIGN CHECK</td> <td></td> <td></td> </tr> <tr> <td>PROJECT MANAGER</td> <td></td> <td></td> </tr> <tr> <td>PROJECT DIRECTOR</td> <td></td> <td></td> </tr> </tbody> </table>		DESIGNATION	NAME	DATE	DRAFTSMAN			DESIGNER			DESIGN CHECK			PROJECT MANAGER			PROJECT DIRECTOR			DOUBLE POLE CROSS ARM ASSEMBLY - 11.2M TELESCOPIC POLE (11 kV & 33kV)	
		DESIGNATION	NAME	DATE																	
		DRAFTSMAN																			
		DESIGNER																			
		DESIGN CHECK																			
PROJECT MANAGER																					
PROJECT DIRECTOR																					
DRAWING NO. BPC-DDCS-2015-34/2		REVISION 2015																			

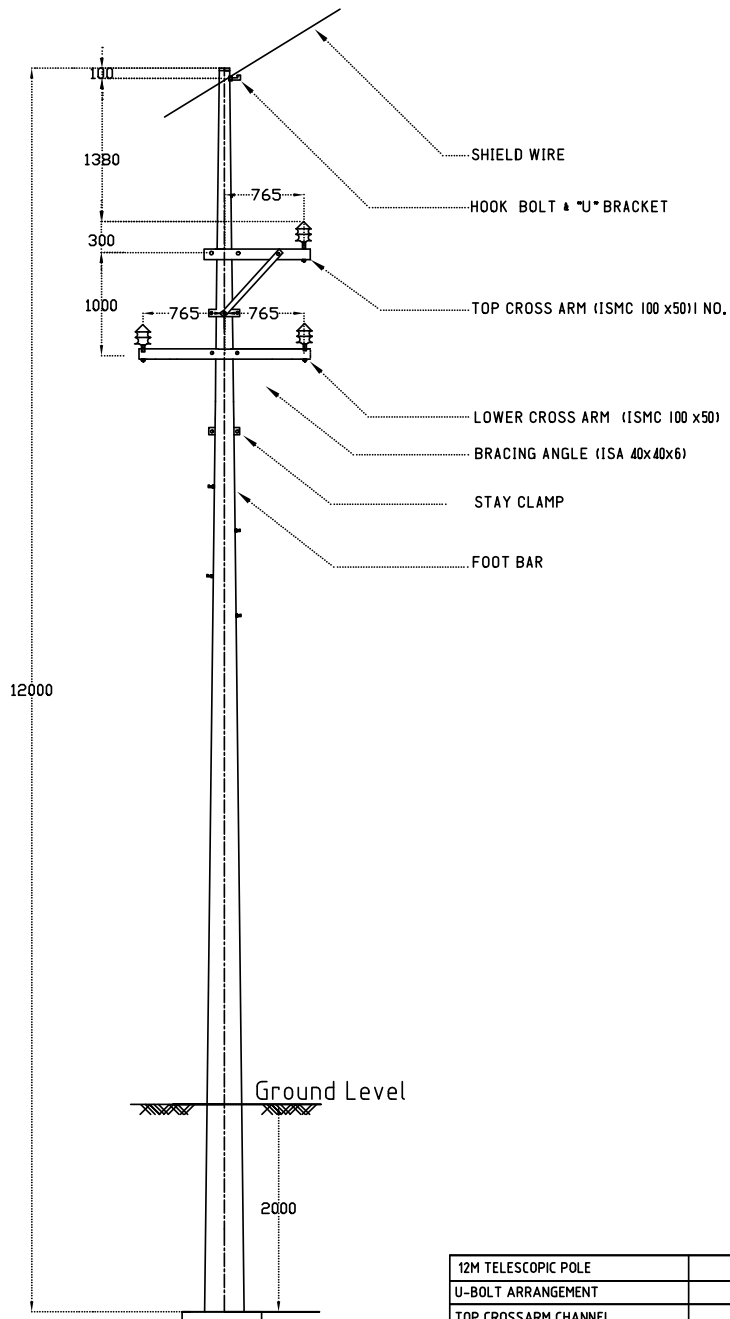

NOTES

1. DIMENSIONS AS SHOWN ARE IN mm.
2. DRAWING IS NOT TO SCALE.
3. PROVIDE 18MM DIA THROUGH HOLE AT 100MM BELOW THE POLE TOP FOR FIXING THE HOOK BOLT & U-BRACKET

12M TELESCOPIC POLE	2	GS
U-BOLT ARRANGEMENT	1	GS
TOP CROSSARM CHANNEL	1	GS
LOWER CROSSARM CHANNEL	1	GS
PIN INSULATOR	3	PORCELAIN
CLAMP WITH NUTS & BOLTS	1	GS
STAY CLAMP	1	GS
DESCRIPTION	QTY	MATERIAL



BHUTAN POWER CORPORATION LIMITED

ENGINEERING DESIGN & CONTRACTS DEPARTMENT

DISTRIBUTION DESIGN & CONSTRUCTION STANDARD

SINGLE POLE ASSEMBLY FOR 12 M TELESCOPIC POLE WITH GROUNDWIRE (11 KV & 33KV)

	NAME	DATE
DESIGNED BY		
CHECKED BY		
APPROVED BY		

DRAWING NO. BPC-DDCS-2015-35/1

REVISION
2015

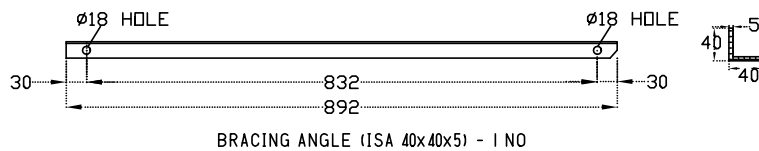
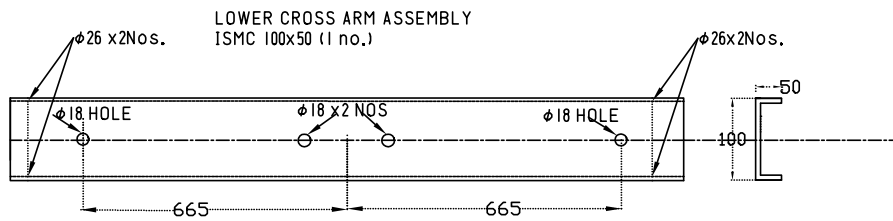
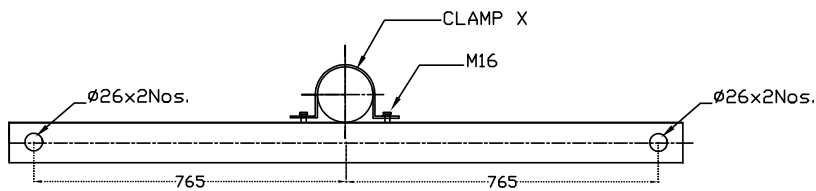
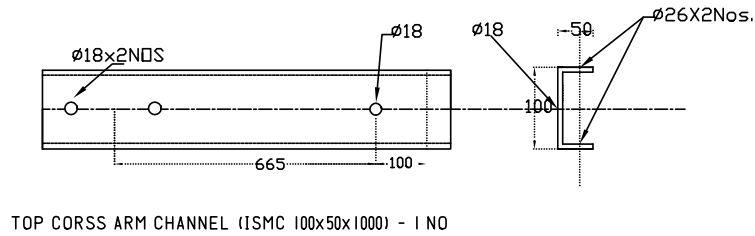
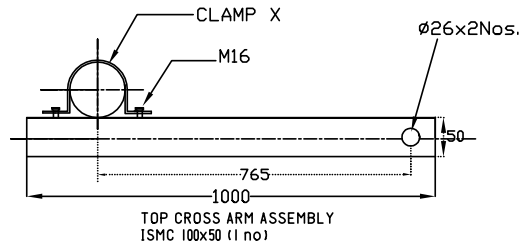

NOTES

1. DIMENSIONS AS SHOWN ARE IN mm.
2. DRAWING IS NOT TO SCALE.
3. LENGTH OF THE BRACING ANGLE SHALL BE DESIGNED BY THE SUPPLIER

 <p>BHUTAN POWER CORPORATION LIMITED</p>	ENGINEERING DESIGN & CONTRACTS DEPARTMENT	
	TITLE : DISTRIBUTION DESIGN & CONSTRUCTION STANDARD	
SINGLE POLE ASSEMBLY FOR 12 M TELESCOPIC POLE WITH GROUNDWIRE (11 kV & 33kV)		
DESIGNED BY	NAME	DATE
CHECKED BY		
APPROVED BY		
DRAWING NO. BPC-DDCS-2015-35/2		REVISION 2015

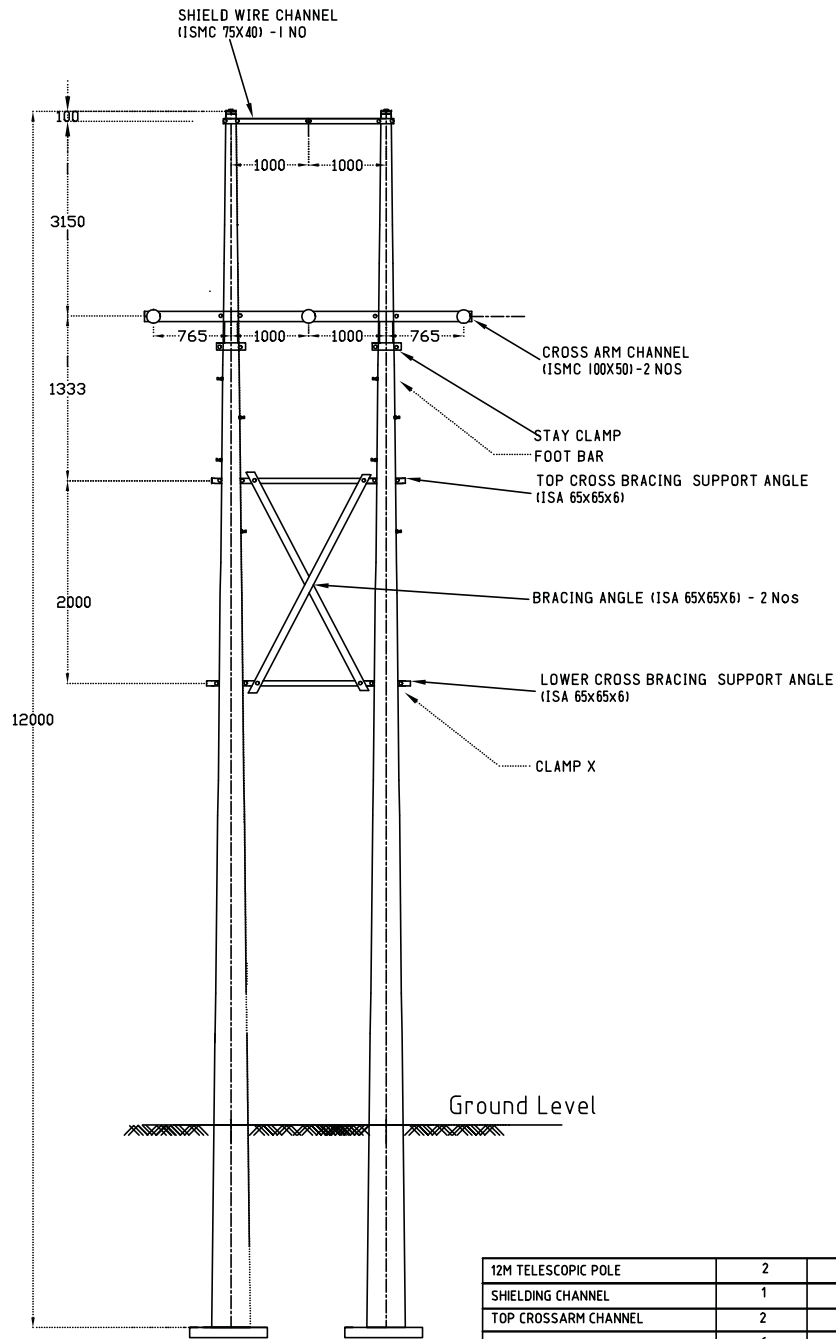

NOTES

DIMENSIONS AS SHOWN ARE IN mm.
DRAWING IS NOT TO SCALE.

12M TELESCOPIC POLE	2	GS
SHIELDING CHANNEL	1	GS
TOP CROSSARM CHANNEL	2	GS
DISC INSULATOR SET	6	PORCELAIN
PIN INSULATOR SET	3	PORCELAIN
CLAMP WITH NUTS & BOLTS	1	GS
BRACING ANGLE SET	1	GS
STAY CLAMP SET	2	GS
DESCRIPTION	QTY	MATERIAL

 <p>BHUTAN POWER CORPORATION LIMITED</p>	ENGINEERING DESIGN & CONTRACTS DEPARTMENT	
	DISTRIBUTION DESIGN & CONSTRUCTION STANDARD	
DOUBLE POLE ASSEMBLY FOR 12 M TELESCOPIC POLE WITH GROUNDWIRE (11 KV & 33KV)		
DESIGNED BY	NAME	DATE
CHECKED BY		
APPROVED BY		
DRAWING NO. BPC -DDCS -2015-36/1		REVISION 2015

SHIELD WIRE CROSSARM ASSEMBLY
ISMC 75X40, 1 NO.

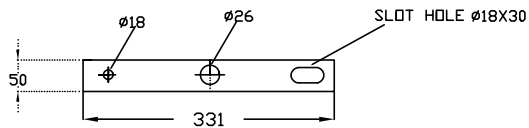
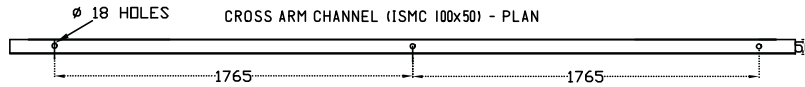
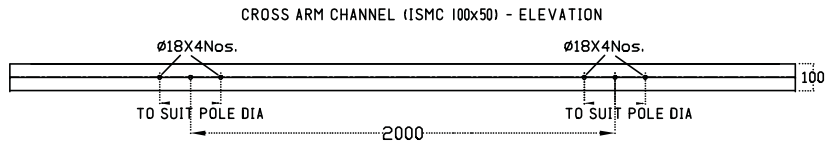
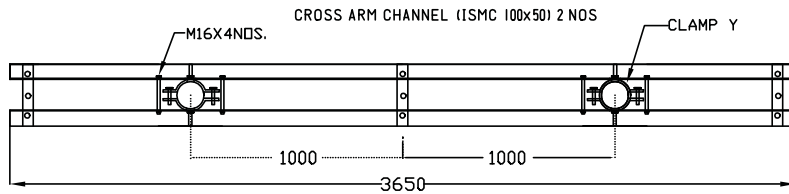
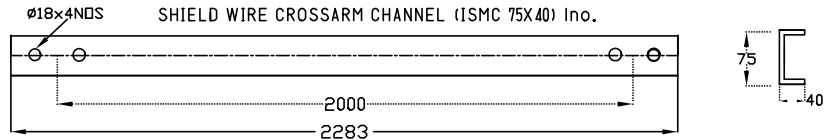
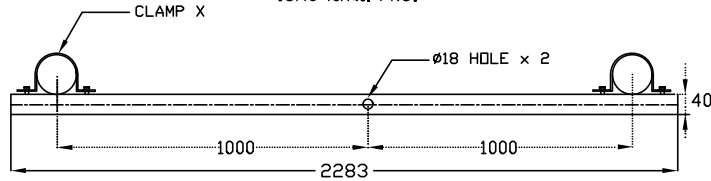

MS TENSION STRAP (50x6) - 6 NOS

NOTES

1. DIMENSIONS AS SHOWN ARE IN mm.
2. DRAWING IS NOT TO SCALE.

	BHUTAN POWER CORPORATION LIMITED		ENGINEERING DESIGN & CONTRACTS DEPARTMENT	
	TITLE : DISTRIBUTION DESIGN & CONSTRUCTION STANDARD		DOUBLE POLE ASSEMBLY FOR 12 M TELESCOPIC POLE WITH GROUNDWIRE (11 kV & 33kV)	
DESIGNED BY	NAME	DATE	DRAWING NO. BPC-DDCS-2015-36/2	
CHECKED BY				
APPROVED BY				
			REVISION 2015	

ANGLE FOR TOP CROSS BRACING SUPPORT (ISA 65x65x6) - 1 NO

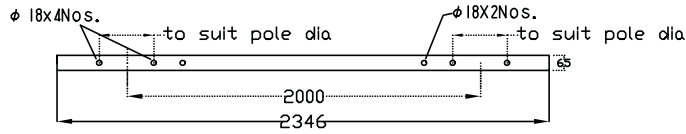

ANGLE FOR LOWER CROSS BRACING SUPPORT (ISA 65x65x6) - 1 NO

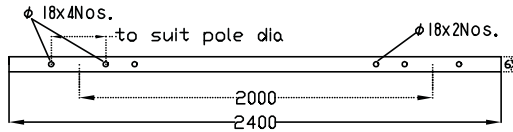

ANGLE FOR CROSS BRACING (ISA 65 x 65 x 6) - 2 NOS

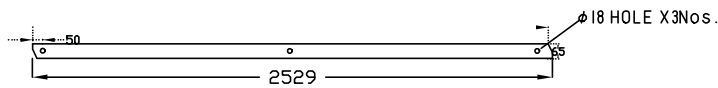

SHIELDING ARRANGEMENT ON DOUBLE POLE STRUCTURES

SHIELD WIRE CHANNEL

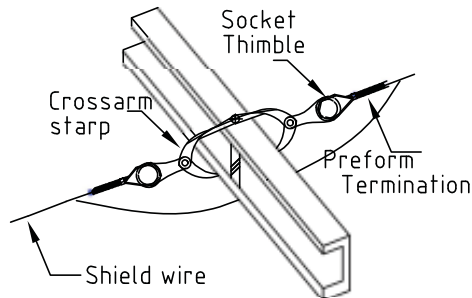

NOTES

1. DIMENSIONS AS SHOWN ARE IN mm.
2. DRAWING IS NOT TO SCALE.
3. LENGTH OF THE CROSS BRACING ANGLE SHALL BE DESIGNED BY THE SUPPLIER

 <p>BHUTAN POWER CORPORATION LIMITED</p>	ENGINEERING DESIGN & CONTRACTS DEPARTMENT	
	TITLE : DISTRIBUTION DESIGN & CONSTRUCTION STANDARD	
DOUBLE POLE ASSEMBLY FOR 12 M TELESCOPIC POLE WITH GROUNDWIRE (11 kV & 33kV)		
DESIGNED BY	NAME	DATE
CHECKED BY		
APPROVED BY		
DRAWING NO. BPC-DDCS-2015-36/3		REVISION 2015

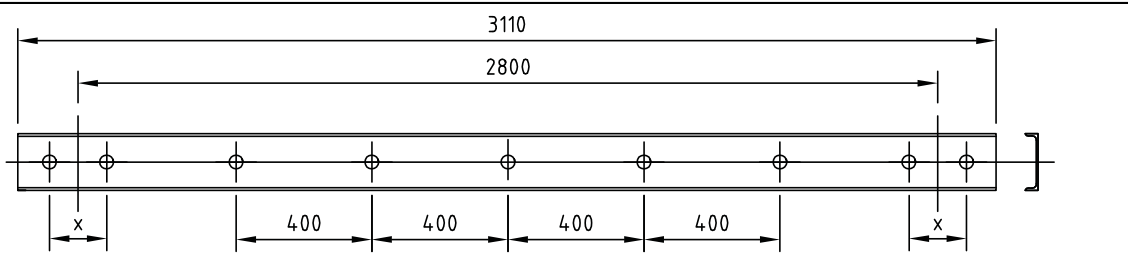

"x" TO SUIT OD OF POLE,
EQUIPMENT SUPPORTS,
CH 75x40 (3NOS)

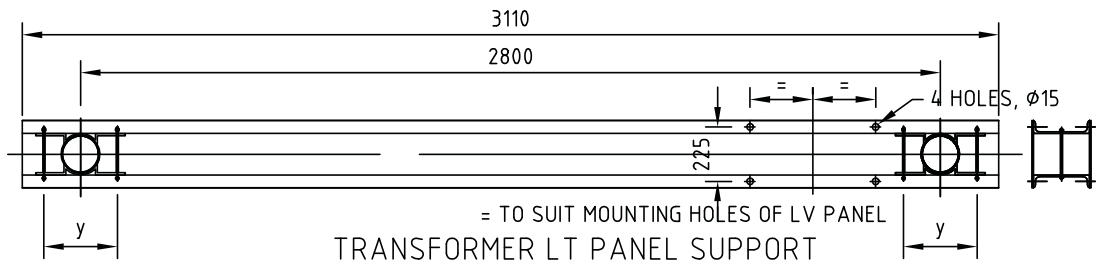

"y" TO SUIT NOM 165 OD OF POLE,
= TO SUIT MOUNTING HOLES OF LV PANEL
TRANSFORMER LT PANEL SUPPORT
CH 100x50

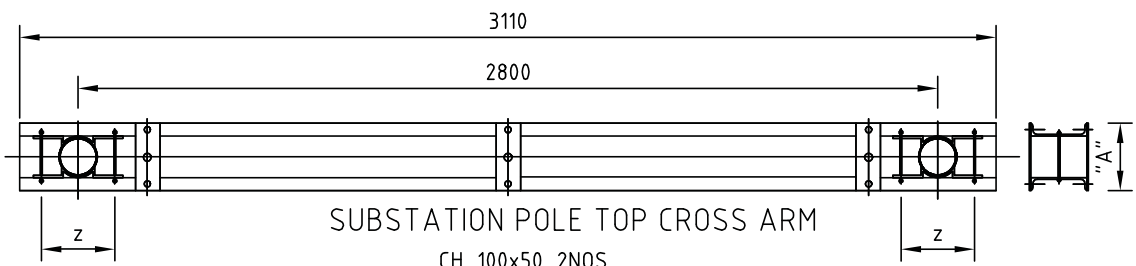

"z" TO SUIT OD OF POLE
SUBSTATION POLE TOP CROSS ARM
CH 100x50 2NOS

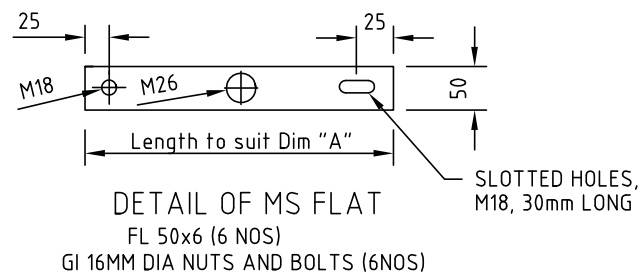

DETAIL OF MS FLAT
FL 50x6 (6 NOS)
GI 16MM DIA NUTS AND BOLTS (6NOS)

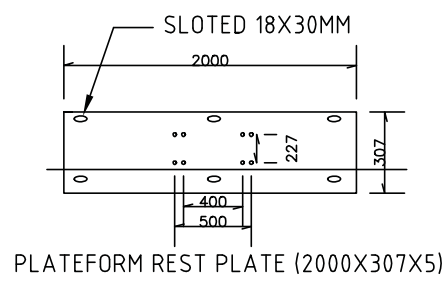

PLATFORM REST PLATE (2000X307X5)

NOTES

1. DIMENSIONS AS SHOWN ARE IN mm.
2. DRAWING IS NOT TO SCALE.
3. TRANSFORMER LT PANEL SUPPORT REQUIRE ONLY FOR 125kVA TRANSFORMERS
4. GENERAL ARRANGEMENT OF SUBSTATION BE REFERRED FROM DRAWING NO. BPC-DDCS--(9 TO 11)

	BHUTAN POWER CORPORATION LIMITED	ENGINEERING DESIGN & CONTRACTS DEPARTMENT	
		DISTRIBUTION DESIGN & CONSTRUCTION STANDARD	
POLE MOUNTED SUBSTATIONSTRUCTURE DETAILS FOR STEEL TUBULAR POLE		DRAWING NO. BPC-DDCS-2015-37/1	REVISION 2015
DESIGNATION	NAME		
DRAFTSMAN			
DESIGNER			
DESIGN CHECK			
PROJECT MANAGER			
PROJECT DIRECTOR			

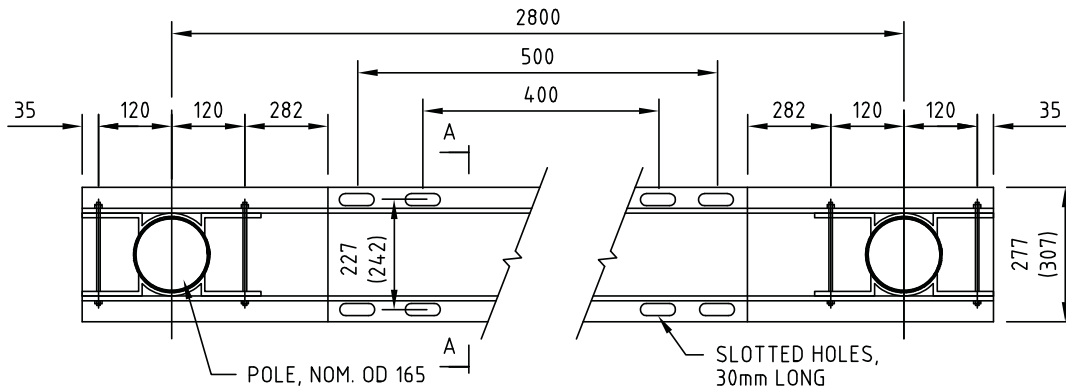

TRANSFORMER PLATFORM (2Nos.)
ISMC 125x65

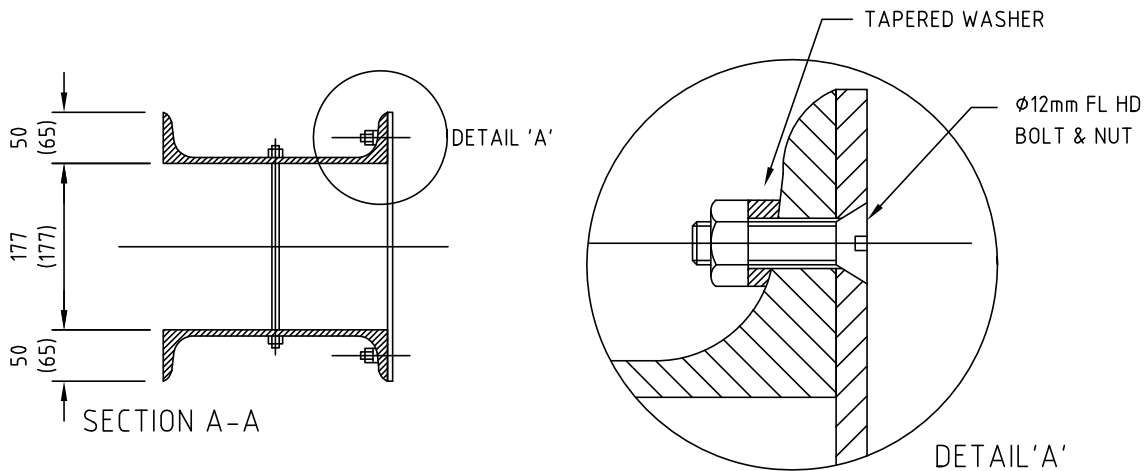
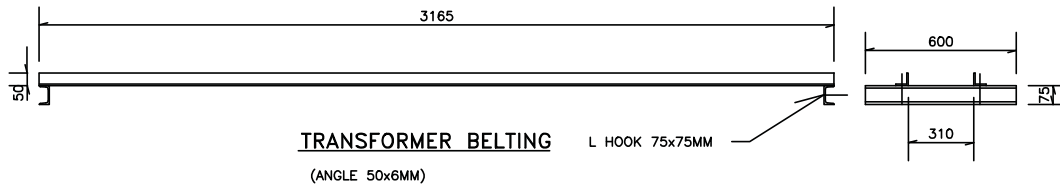

NOTES

1. DIMENSIONS AS SHOWN ARE IN mm.
2. DRAWING IS NOT TO SCALE.
3. 400 mm hole centre to centre length for 25 kVA and below
500 mm hole centre to centre length for 63 kVA and above

	<p>BHUTAN POWER CORPORATION LIMITED</p>	ENGINEERING DESIGN & CONTRACTS DEPARTMENT	
		<p>DISTRIBUTION DESIGN & CONSTRUCTION STANDARD</p> <p>33 & 11 kV TRANSFORMER PLATFORM FOR STEEL TUBULAR POLE</p>	
DESIGNATION	NAME	DATE	<p>DRAWING NO. BPC-DDCS-2015-37/2</p> <p>REVISION 2015</p>
DRAFTSMAN			
DESIGNER			
DESIGN CHECK			
PROJECT MANAGER			
PROJECT DIRECTOR			

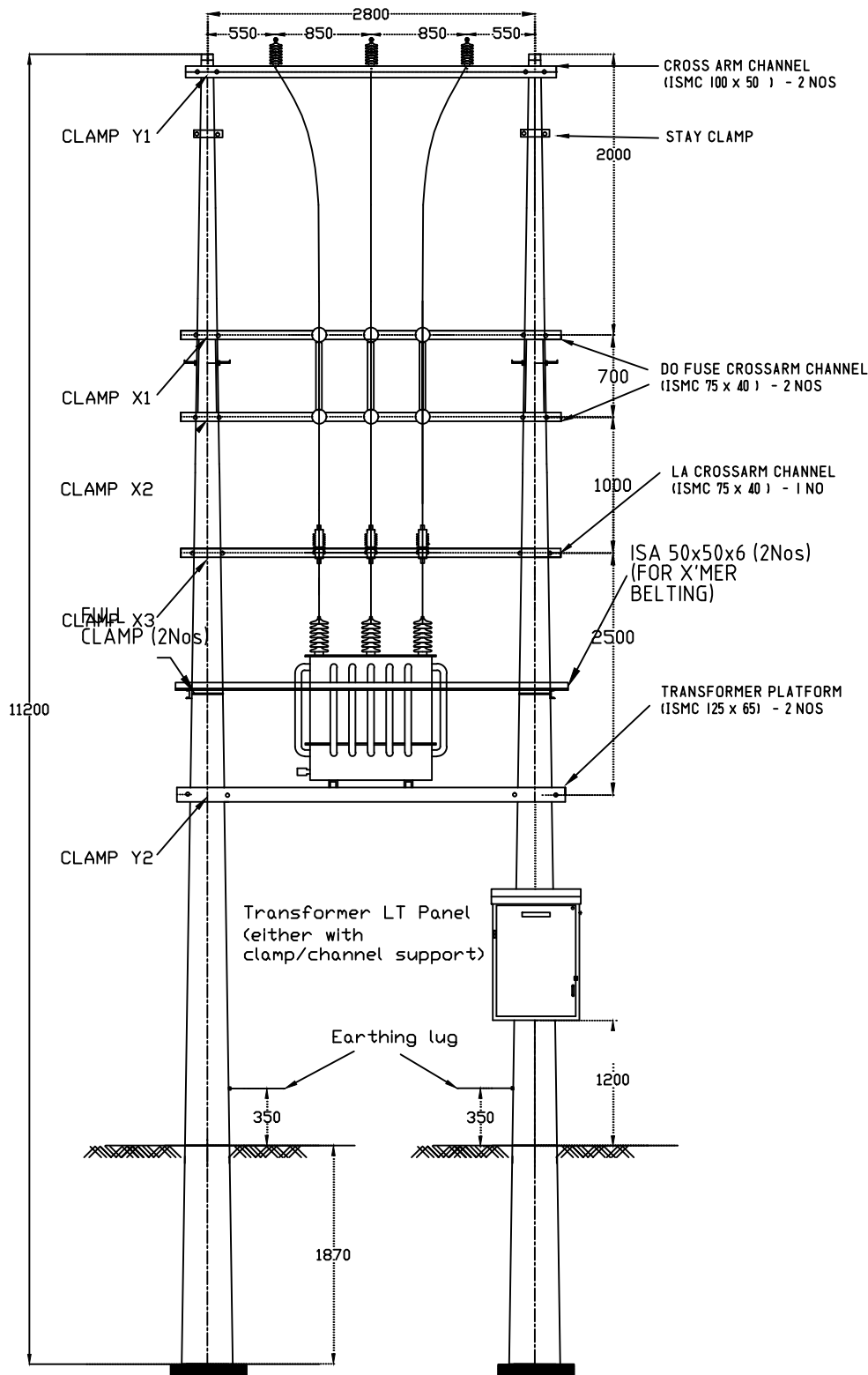

NOTES

1. DISTRIBUTION PILLAR MOUNTING CHANNEL ONLY REQUIRE FOR 125 kVA TRANSFORMERS
2. MOUNTING HEIGHT OF THE TOP DO FUSE TO BE ADJUSTED WITHIN 6M FOR USE OF HOT STICK



BHUTAN POWER CORPORATION LIMITED

ENGINEERING DESIGN & CONTRACTS DEPARTMENT

DISTRIBUTION DESIGN & CONSTRUCTION STANDARD

SUBSTATION STRUCTURE ASSEMBLY FOR 11.2 M TELESCOPIC POLE

	NAME	DATE
DESIGNED BY		
CHECKED BY		
APPROVED BY		

DRAWING NO. BPC-DDCS-2015-38/1

REVISION
2015

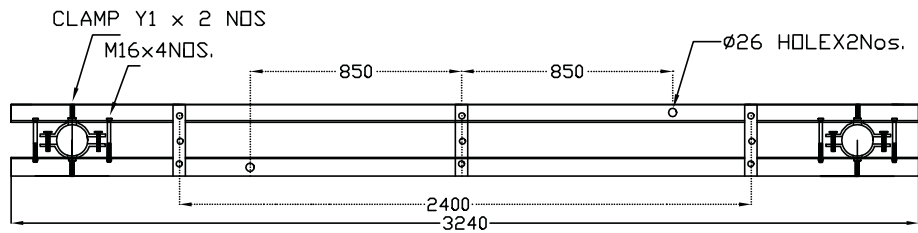

TOP CROSSARM ASSEMBLY

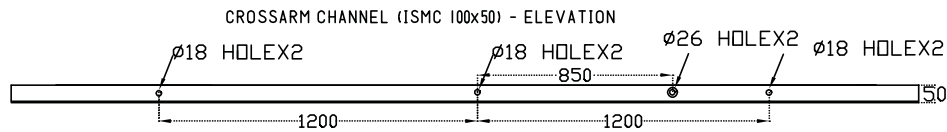
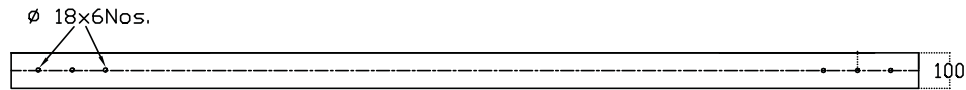

CROSSARM CHANNEL (ISMC 100x50) - PLAN

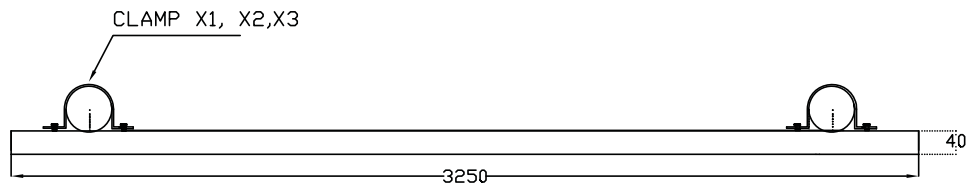

EQUIPMENT CROSSARM CHANNEL ASSEMBLY

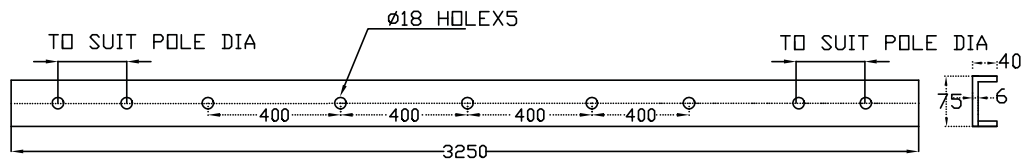

EQUIPMENT CROSSARM CHANNEL (ISMC 75x40) - 3 NOS

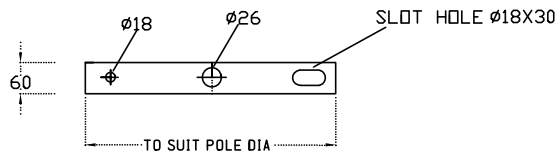

MS TENSION STRAP (60x6) - 6 NOS

NOTES

1. DIMENSIONS AS SHOWN ARE IN mm.
2. DRAWING IS NOT TO SCALE.

	<p>BHUTAN POWER CORPORATION LIMITED</p>		ENGINEERING DESIGN & CONTRACTS DEPARTMENT	
			TITLE : DISTRIBUTION DESIGN & CONSTRUCTION STANDARD	
DESIGNED BY	NAME	DATE	<p>SUBSTATION (1 or 3 PHASE) STRUCTURE CROSS-ARM ASSEMBLY FOR 11.2 M TELESCOPIC POLE</p>	
CHECKED BY				
APPROVED BY				

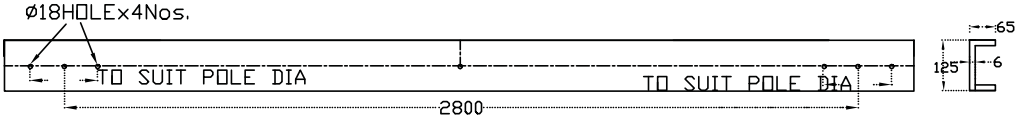
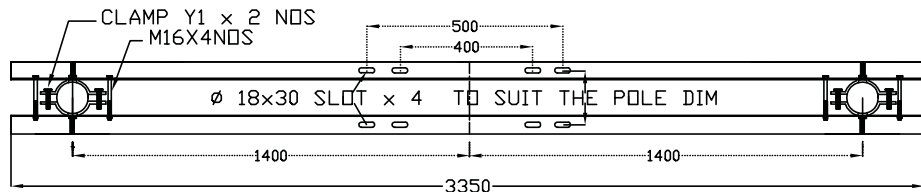

TRANSFORMER SUPPORT CROSSARM CHANNEL (ISMC 125x65) - 2 NOS - ELEVATION

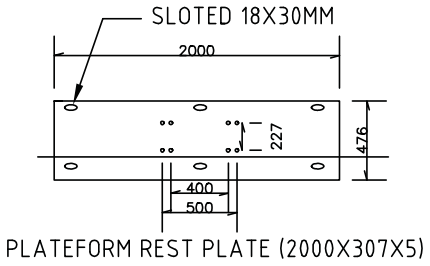
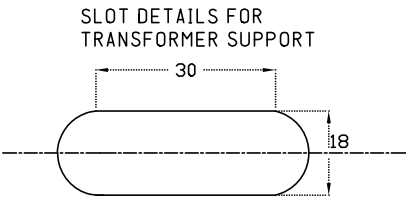
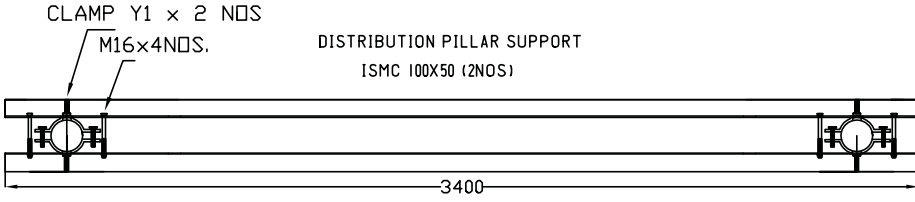
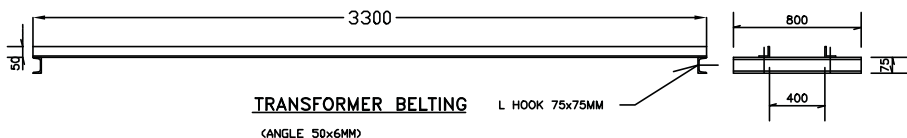

NOTES

1. DIMENSIONS AS SHOWN ARE IN mm.
2. DRAWING IS NOT TO SCALE.
3. The hole centre to hole centre 400mm for trfs upto 25 kVA, 500mm for trfs above 25kVA

 <p>BHUTAN POWER CORPORATION LIMITED</p>	ENGINEERING DESIGN & CONTRACTS DEPARTMENT	
	TITLE : DISTRIBUTION DESIGN & CONSTRUCTION STANDARD	
SUBSTATION (1 or 3 PHASE) STRUCTURE CROSS-ARM ASSEMBLY FOR 11.2 M TELESCOPIC POLE		
DESIGNED BY	NAME	DATE
CHECKED BY		
APPROVED BY		
DRAWING NO. BPC-DDCS-2015-38/3		REVISION 2015

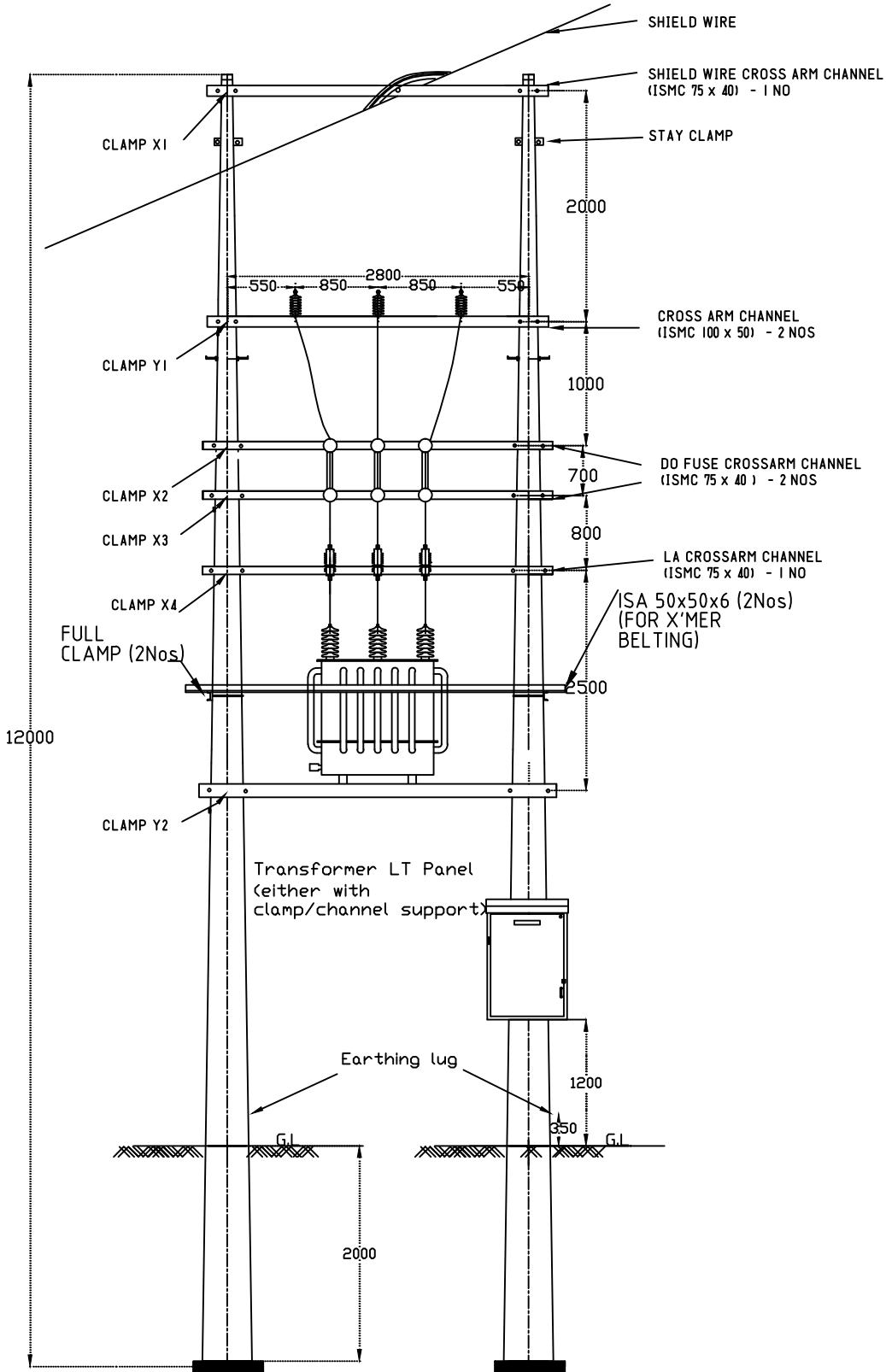

DISTRIBUTION PILLAR MOUNTING CHANNEL ONLY REQUIRE FOR 125 kVA TRANSFORMERS
 MOUNTING HEIGHT OF THE TOP DO FUSE TO BE ADJUSTED WITHIN 6M FOR USE OF HOT STICK



BHUTAN POWER CORPORATION LIMITED

ENGINEERING DESIGN & CONTRACTS DEPARTMENT

DISTRIBUTION DESIGN & CONSTRUCTION STANDARD

SUBSTATION (3 PHASE) STRUCTURE ASSEMBLY - 12 M
 TELESCOPIC POLE WITH SHIELDWIRE

DESIGNED BY	NAME	DATE
CHECKED BY		
APPROVED BY		

DRAWING NO. BPC-DDCS-2015-39/1

REVISION
2015

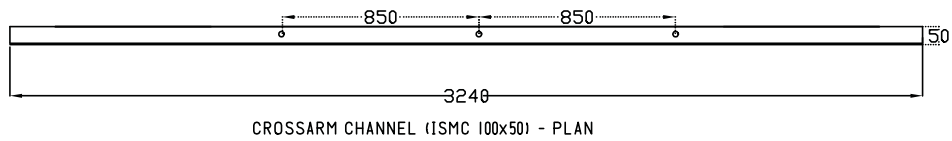
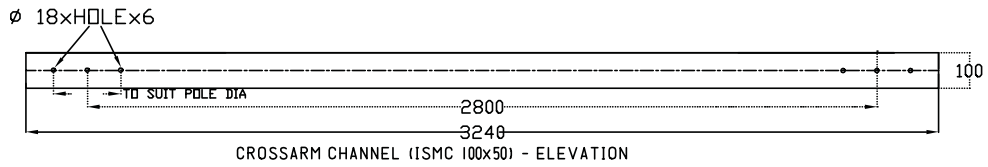
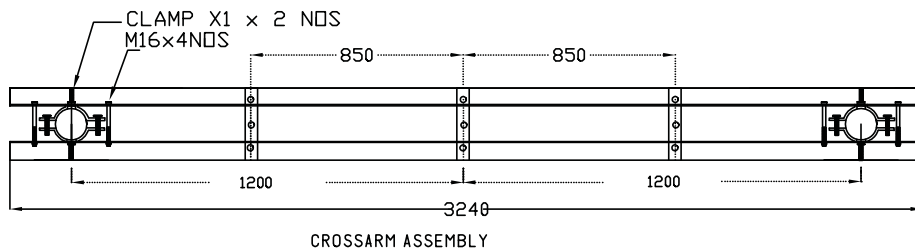
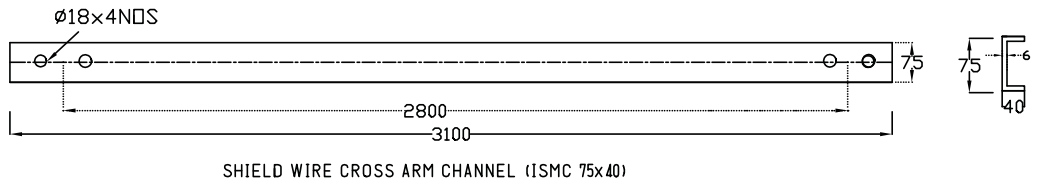
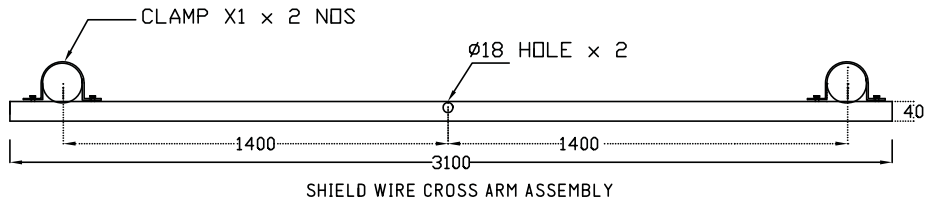

NOTES

1. DIMENSIONS AS SHOWN ARE IN mm.
2. DRAWING IS NOT TO SCALE.



BHUTAN POWER CORPORATION LIMITED

ENGINEERING DESIGN & CONTRACTS DEPARTMENT

DISTRIBUTION DESIGN & CONSTRUCTION STANDARD

SUBSTATION (1 or 3 PHASE) STRUCTURE CROSS-ARM ASSEMBLY FOR 12 M TELESCOPIC POLE WITH SHIELD WIRE

	NAME	DATE
DESIGNED BY		
CHECKED BY		
APPROVED BY		

DRAWING NO. BPC-DDCS-2015-39/2

REVISION
2015

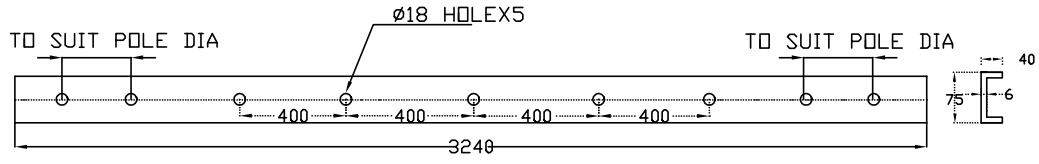

EQUIPMENT CROSSARM CHANNEL (ISMC 75x40x6) - 3 NOS

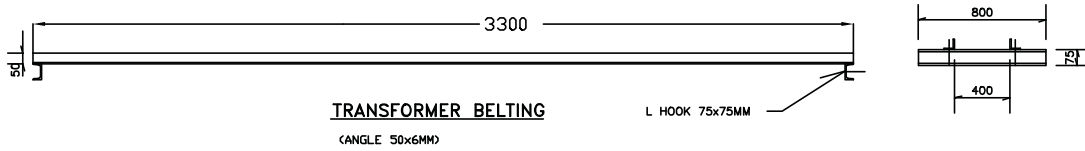

TRANSFORMER BELTING

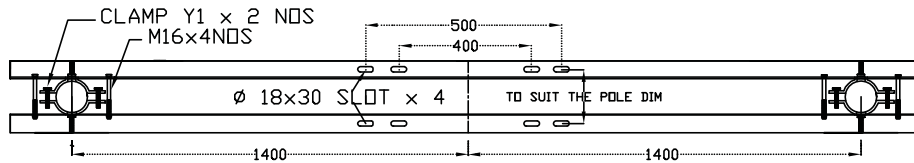

TRANSFORMER SUPPORT CROSSARM CHANNEL (ISMC 125x65x6) - 2 NOS - ELEVATION

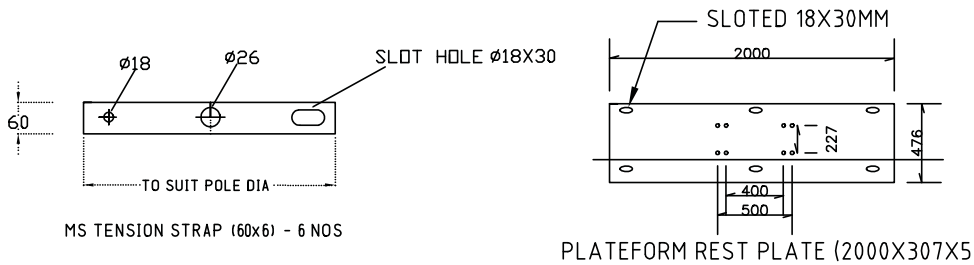
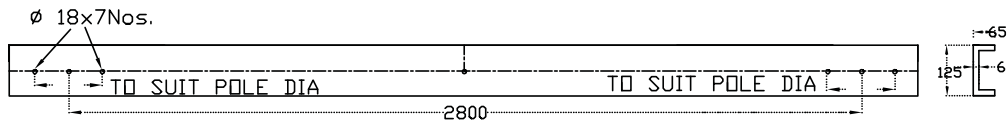

PLATFORM REST PLATE (2000X307X5)

SLOT DETAILS

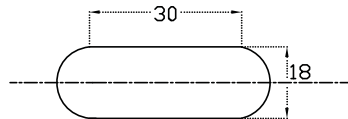

NOTES

1. DIMENSIONS AS SHOWN ARE IN mm.
2. DRAWING IS NOT TO SCALE.
3. The hole centre to hole centre 400mm for trfs upto 25 kVA, 500mm for trfs above 63 kVA

	<p>BHUTAN POWER CORPORATION LIMITED</p>		<p>ENGINEERING DESIGN & CONTRACTS DEPARTMENT</p>	
	<p>DISTRIBUTION DESIGN & CONSTRUCTION STANDARD</p>		<p>SUBSTATION (1 or 3 PHASE) STRUCTURE CROSS-ARM ASSEMBLY FOR 12 M TELESCOPIC POLE WITH SHIELD WIRE</p>	
DESIGNED BY	NAME	DATE	<p>DRAWING NO. BPC-DDCS-2015-39/3</p>	
CHECKED BY				
APPROVED BY				
			<p>REVISION 2015</p>	

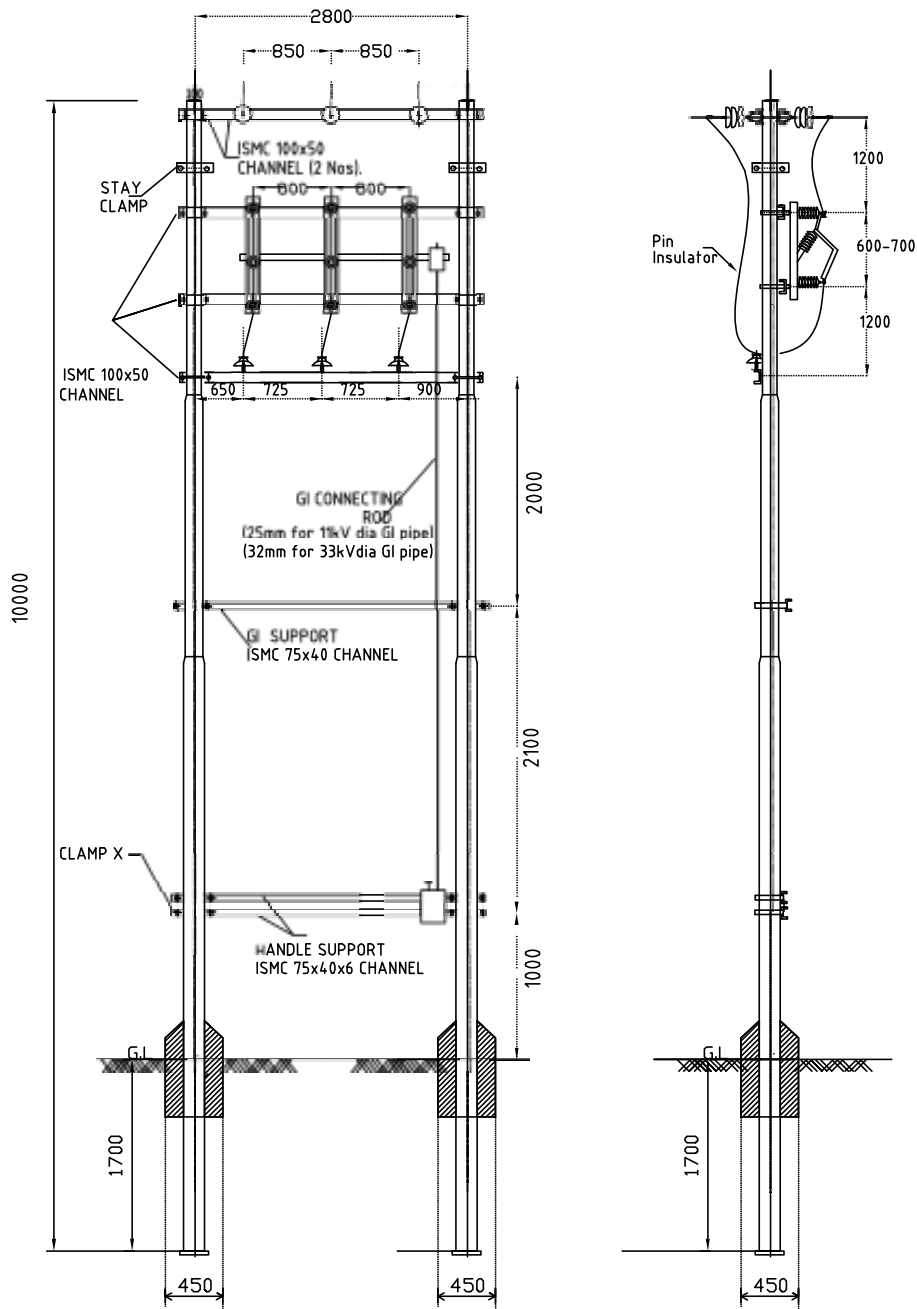

BHUTAN POWER CORPORATION LIMITED

ENGINEERING DESIGN & CONTRACTS DEPARTMENT

DISTRIBUTION DESIGN & CONSTRUCTION STANDARD

11 & 33kV AIRBREAK SWITCH ARRANGEMENT

STEEL TUBULAR POLE

	NAME	DATE
DESIGNED BY		
CHECKED BY		
APPROVED BY		

DRAWING NO. BPC-DDCS-2015-40/1

REVISION
2015

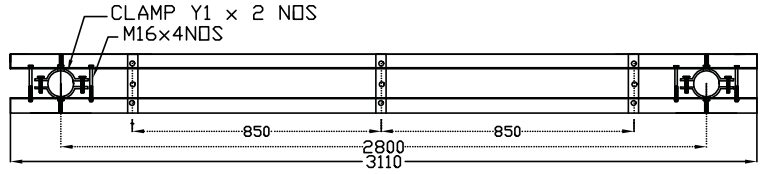

CROSSARM ASSEMBLY

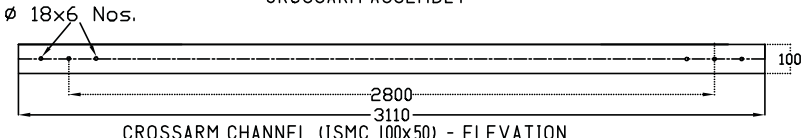

CROSSARM CHANNEL (ISMC 100x50) - ELEVATION

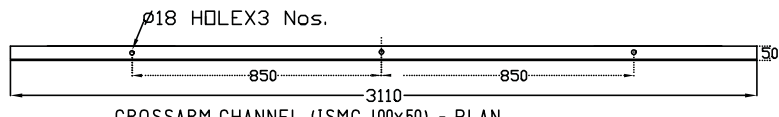

CROSSARM CHANNEL (ISMC 100x50) - PLAN

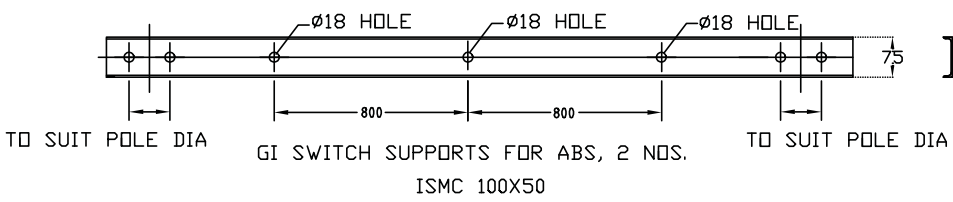

GI SWITCH SUPPORTS FOR ABS, 2 NOS.
ISMC 100X50

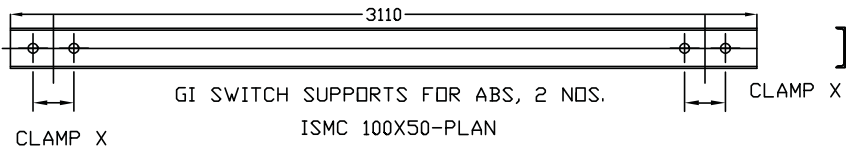

GI SWITCH SUPPORTS FOR ABS, 2 NOS.
ISMC 100X50-PLAN

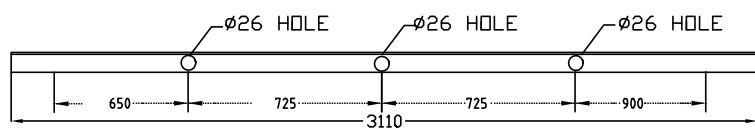

PIN INSULATOR SUPPORTS, 1 NO.
ISMC 100x50

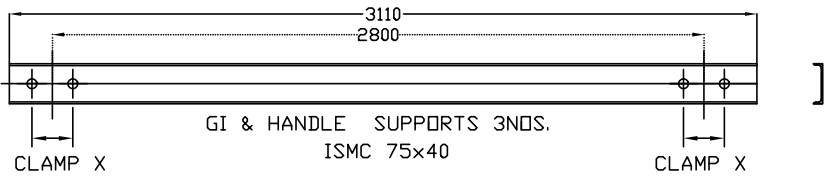

GI & HANDLE SUPPORTS 3NOS.
ISMC 75x40

NOTES

1. DIMENSIONS AS SHOWN ARE IN mm.
2. ALL HOLES ARE 18mm AND ALL BOLTS TO BE 16mm.



BHUTAN POWER CORPORATION LIMITED

ENGINEERING DESIGN & CONTRACTS DEPARTMENT

DISTRIBUTION DESIGN & CONSTRUCTION STANDARD

AIRBREAK SWITCH CROSS-ARM ASSEMBLY FOR STEEL TUBULAR POLE

	NAME	DATE
DESIGNED BY		
CHECKED BY		
APPROVED BY		

DRAWING NO. BPC-DDCS-2015-40/2

REVISION
2015

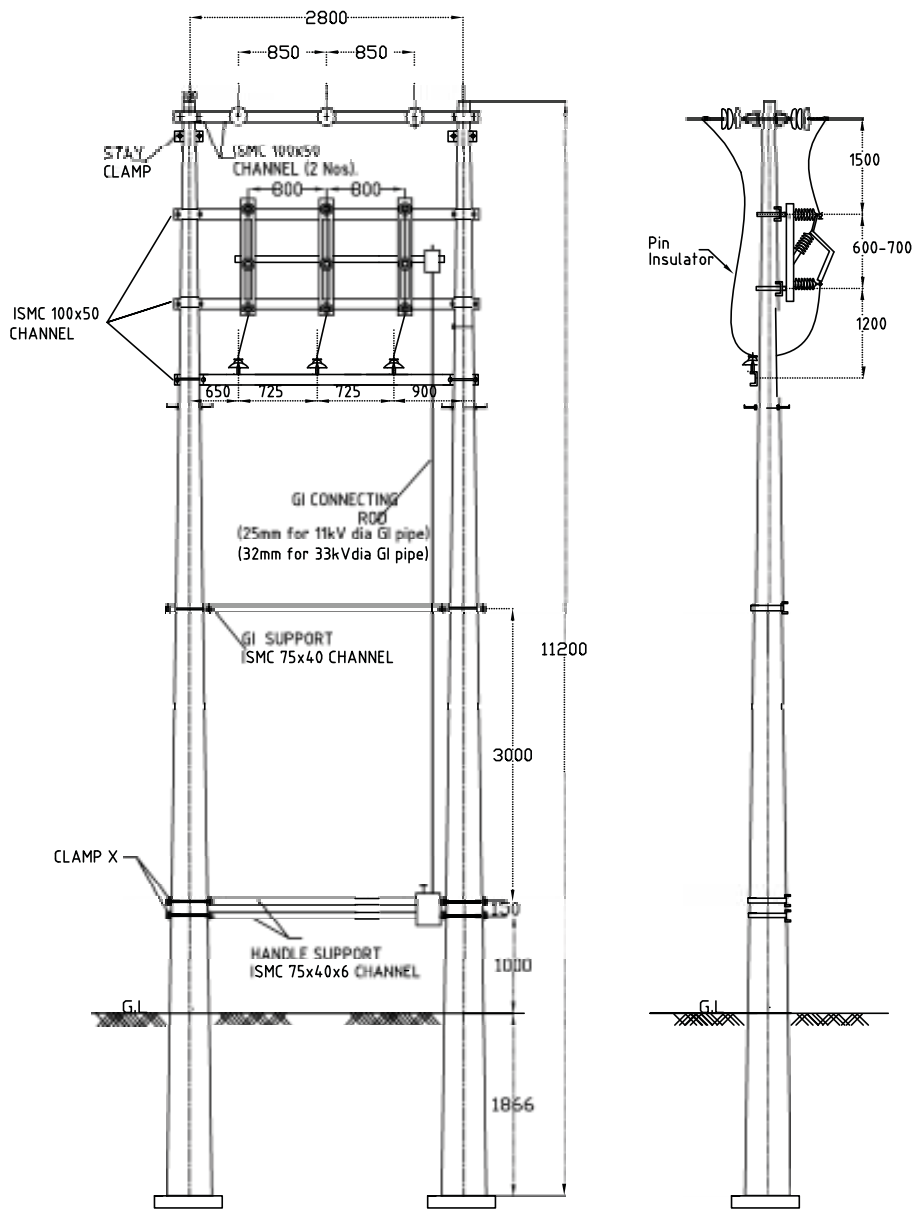

BHUTAN POWER CORPORATION LIMITED

ENGINEERING DESIGN & CONTRACTS DEPARTMENT

DISTRIBUTION DESIGN & CONSTRUCTION STANDARD

11 & 33kV AIRBREAK SWITCH ARRANGEMENT-11.2M

TELESCOPIC POLES

	NAME	DATE
DESIGNED BY		
CHECKED BY		
APPROVED BY		

DRAWING NO. BPC-DDCS-2015-41/1

REVISION
2015

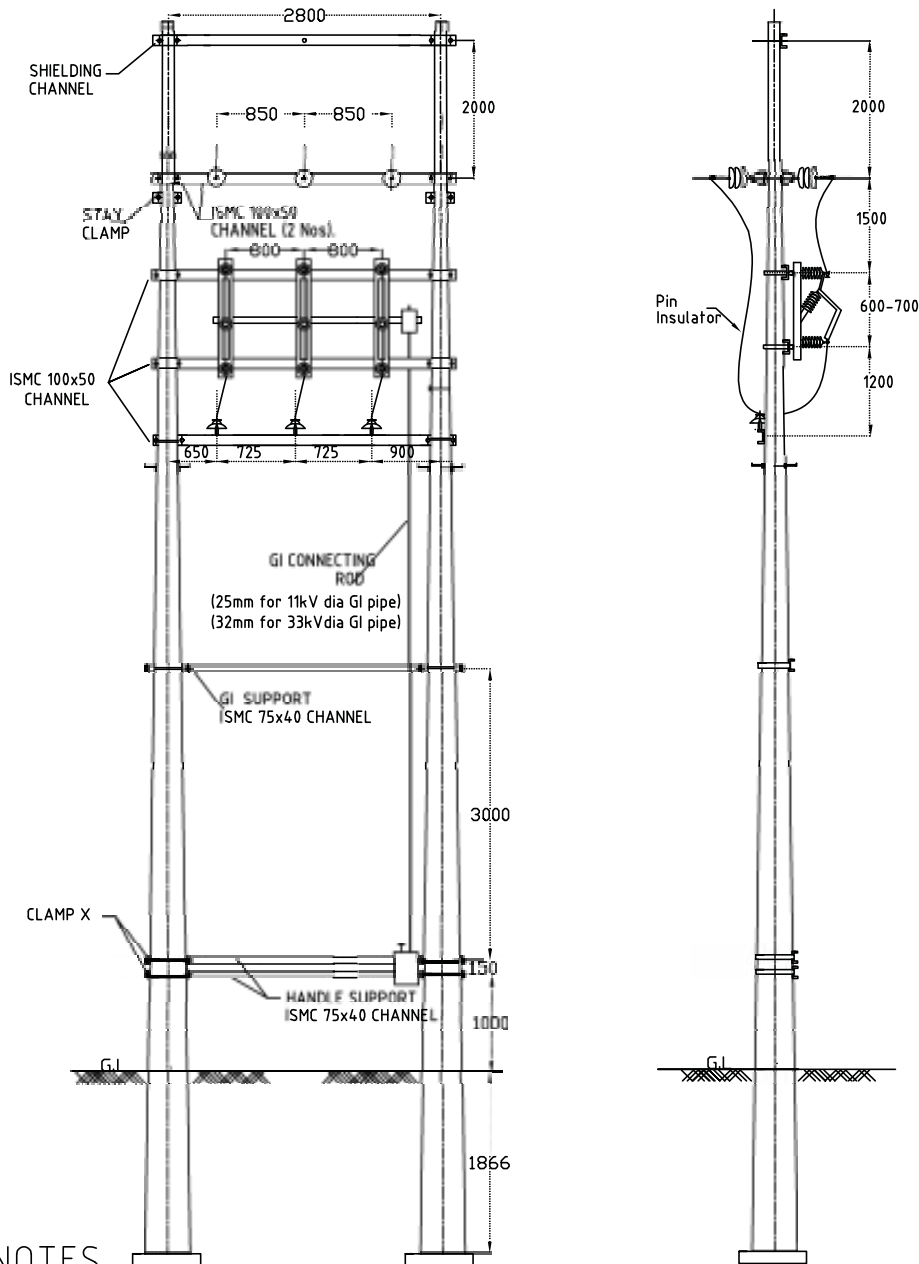

NOTES

1. DIMENSIONS AS SHOWN ARE IN mm.
2. ALL HOLES ARE 18mm AND ALL BOLTS TO BE 16mm.

 <p>BHUTAN POWER CORPORATION LIMITED</p>	ENGINEERING DESIGN & CONTRACTS DEPARTMENT	
	DISTRIBUTION DESIGN & CONSTRUCTION STANDARD	
33 kV AIRBREAK SWITCH ARRANGEMENT-12M TELESCOPIC POLES		
DESIGNED BY	NAME	DATE
CHECKED BY		
APPROVED BY		
DRAWING NO. BPC-DDCS-2015-41/2		REVISION 2015

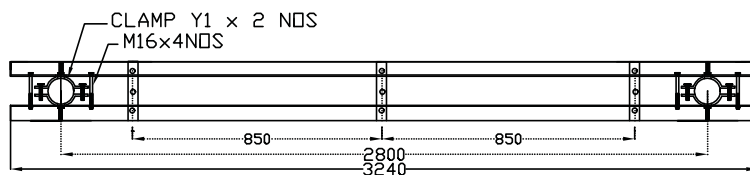

CROSSARM ASSEMBLY

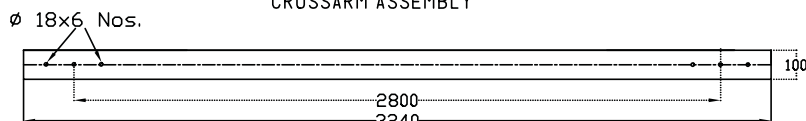

CROSSARM CHANNEL (ISMC 100x50) - ELEVATION

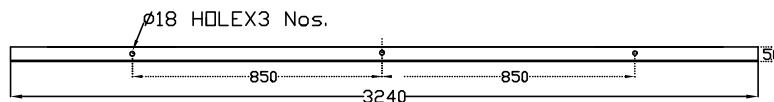

CROSSARM CHANNEL (ISMC 100x50) - PLAN

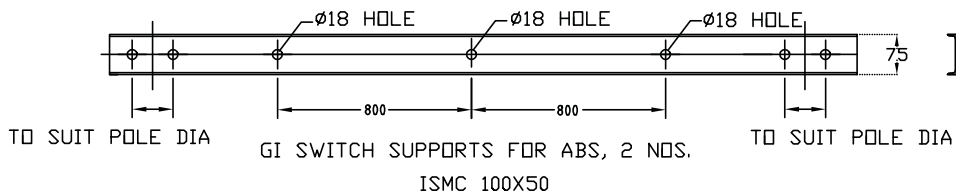

GI SWITCH SUPPORTS FOR ABS, 2 NOS.
ISMC 100X50

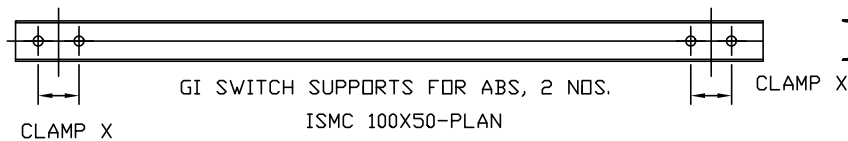

GI SWITCH SUPPORTS FOR ABS, 2 NOS.
ISMC 100X50-PLAN

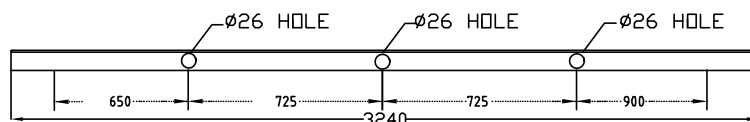

PIN INSULATOR SUPPORTS, 1 NO.
ISMC 100x50

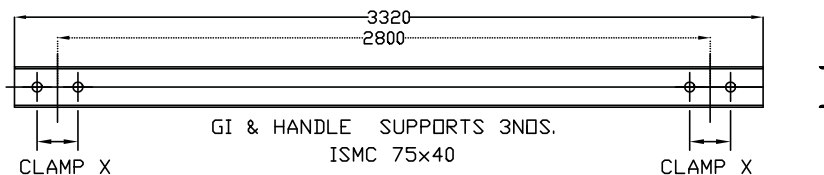

GI & HANDLE SUPPORTS 3NOS.
ISMC 75x40

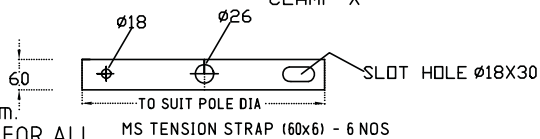

NOTES

1. DIMENSIONS AS SHOWN ARE IN mm.
2. ALL HOLES ARE 18mm AND ALL BOLTS TO BE 16mm.
3. SHIELDING ASSEMBLY FOR 12M POLE TO BE SAME FOR ALL



BHUTAN POWER CORPORATION LIMITED

ENGINEERING DESIGN & CONTRACTS DEPARTMENT

DISTRIBUTION DESIGN & CONSTRUCTION STANDARD

AIRBREAK SWITCH CROSS-ARM ASSEMBLY
FOR 11.2M & 12M TELESCOPIC POLE

	NAME	DATE
DESIGNED BY		
CHECKED BY		
APPROVED BY		

DRAWING NO. BPC-DDCS-2015-41/3

REVISION
2015

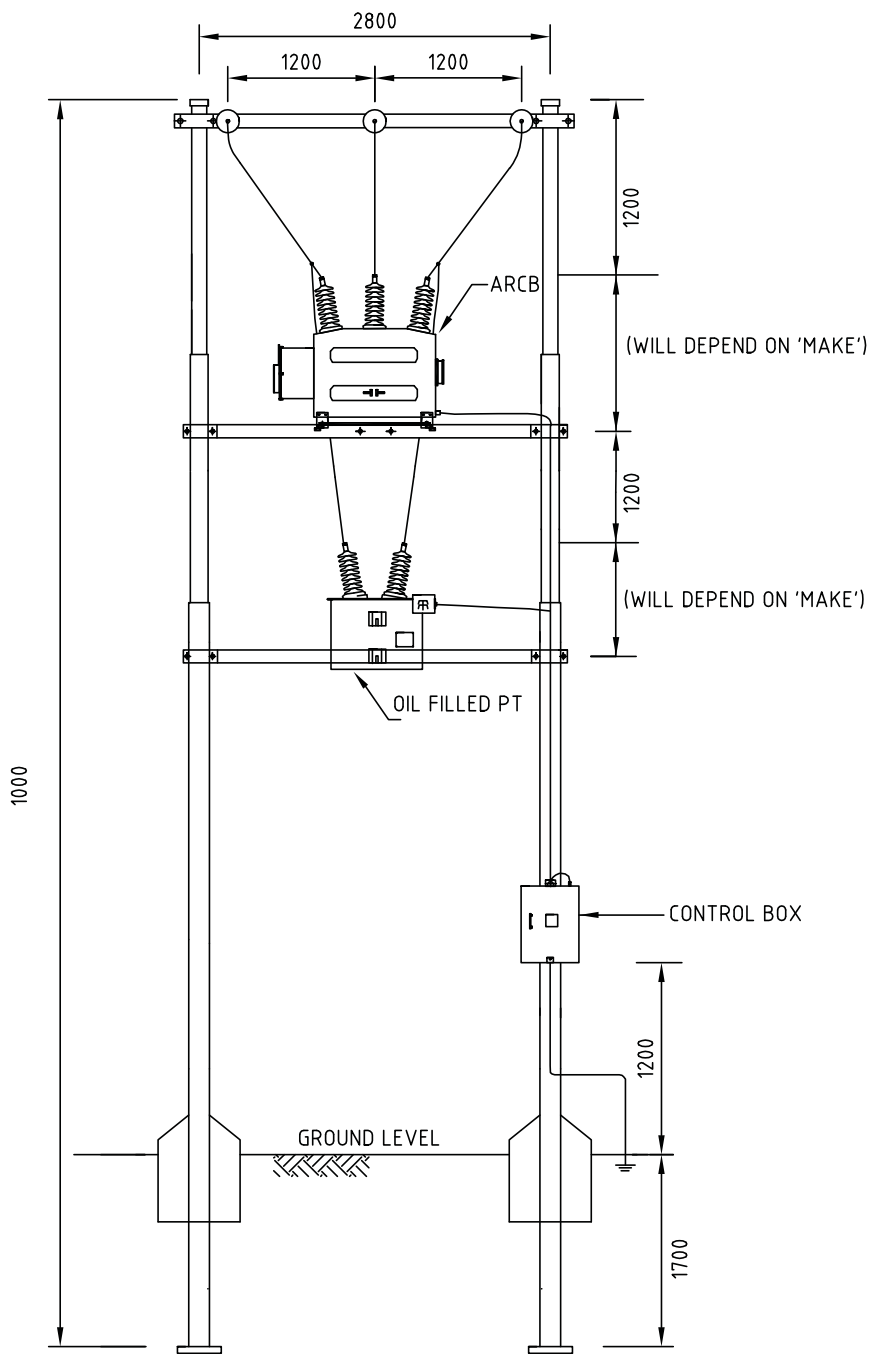

NOTES

1. DIMENSIONS AS SHOWN ARE IN mm.
2. DRAWING IS NOT TO SCALE.

 <p>BHUTAN POWER CORPORATION LIMITED</p>	ENGINEERING DESIGN & CONTRACTS DEPARTMENT	
	DISTRIBUTION DESIGN & CONSTRUCTION STANDARD	
TYPICAL ARCB ARRANGEMENT ON STEEL TUBULAR POLE		
DESIGNED BY	NAME	DATE
CHECKED BY		
APPROVED BY		
DRAWING NO. BPC-DDCS-2015-42/1		REVISION 2015

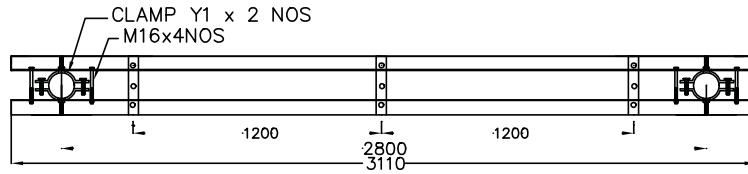

CROSSARM ASSEMBLY

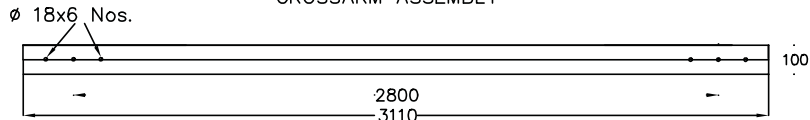

CROSSARM CHANNEL (ISMC 100x50) – ELEVATION

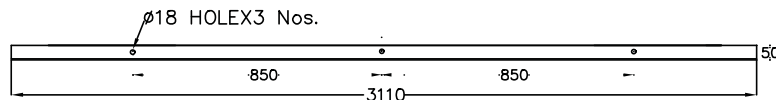

CROSSARM CHANNEL (ISMC 100x50) – PLAN

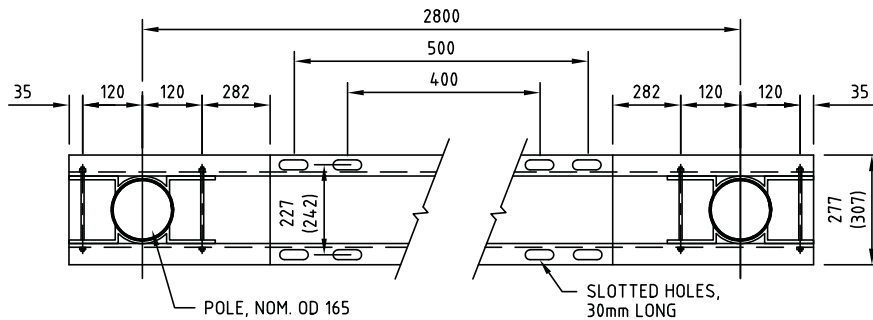

ARCB & PT PLATFORM (2Nos.)
ISMC 125x65

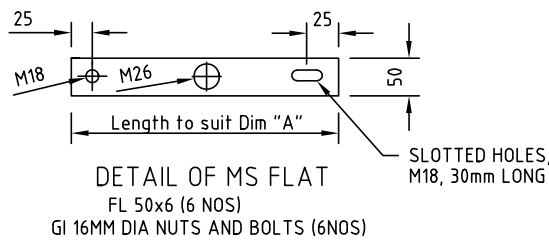

DETAIL OF MS FLAT

FL 50x6 (6 NOS)
GI 16MM DIA NUTS AND BOLTS (6NOS)

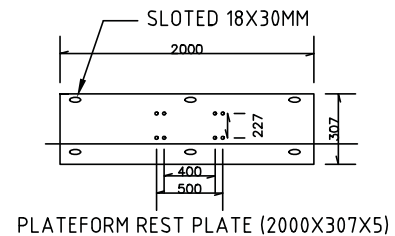

PLATFORM REST PLATE (2000X307X5)

NOTES

1. DIMENSIONS AS SHOWN ARE IN mm.
ALL HOLES ARE 18mm AND ALL BOLTS TO BE 16mm.
DRAWING IS NOT TO SCALE.

	<p>BHUTAN POWER CORPORATION LIMITED</p>		ENGINEERING DESIGN & CONTRACTS DEPARTMENT	
			DISTRIBUTION DESIGN & CONSTRUCTION STANDARD	
DESIGNED BY		NAME		DATE
CHECKED BY		CROSS-ARM ASSEMBLY FOR MOUNTING ARCB ON STEEL TUBULAR POLE		
APPROVED BY		DRAWING NO. BPC-DDCS-2015-42/2		REVISION 2015

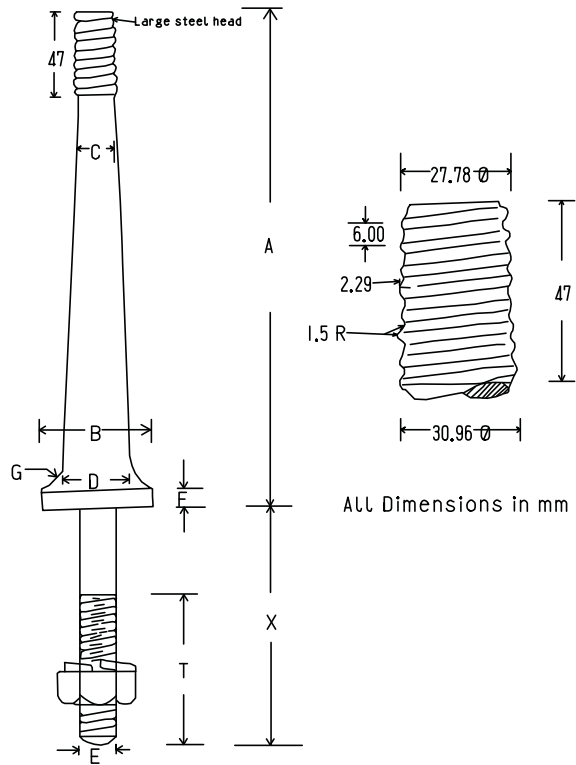
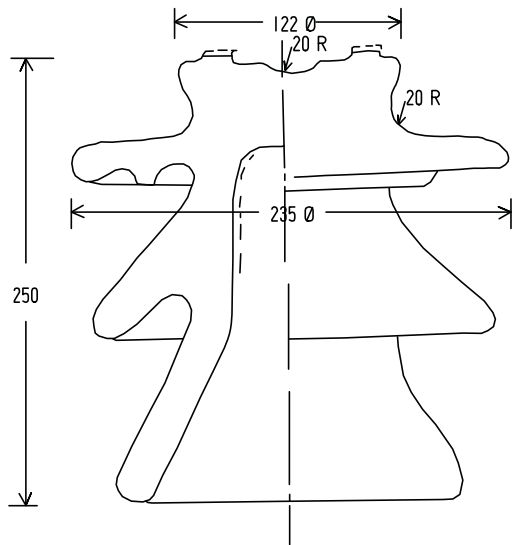

All Dimensions in mm

Specification no. IS 2486 (Part II) 1974
Min. Failing Load.....1080 kg

A	B	C	D	E	F	G	T	X
mm	mm	mm	mm	mm	mm	mm	mm	mm
300	67	27	44	24	6	12	100	150

TECHNICAL DETAILS:

- (a) Highest System Voltage 36kV (rms)
- (b) Wet Power Frequency withstand Test 75kV (rms)
- (c) Power Frequency Puncture withstand Test 180kV (rms)
- (d) Impulse Voltage withstand Test 170kV (peak)
- (e) Minimum Failing Load 1080 kg

Large Steel Head Pin for 33kV Pin Insulator



BHUTAN POWER CORPORATION LIMITED

ENGINEERING DESIGN & CONTRACTS DEPARTMENT

DISTRIBUTION DESIGN & CONSTRUCTION STANDARD

33kV - 10.8 kN PIN INSULATOR - LARGE HEAD

DESIGNATION	NAME	DATE
DRAFTSMAN		
DESIGNER		
DESIGN CHECK		
PROJECT MANAGER		
PROJECT DIRECTOR		

DRAWING NO. BPC-DDCS-2015-43/1

REVISION
2015

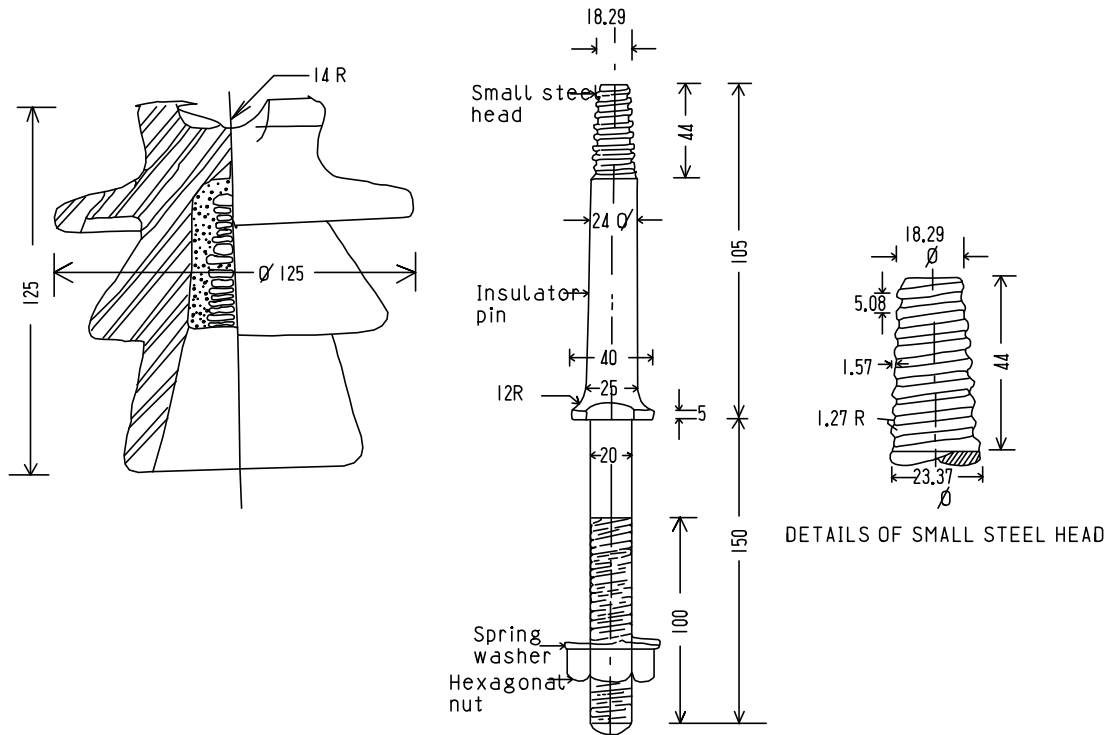

Small Steel Head Pin for 11kV Pin Insulator

Note :

1. Specification no. IS 2486 (Part II)
2. All Dimensions in mm
3. Minimum Failing Load 5 kN

 BHUTAN POWER CORPORATION LIMITED	ENGINEERING DESIGN & CONTRACTS DEPARTMENT	
	DISTRIBUTION DESIGN & CONSTRUCTION STANDARD	
11kV -5kN PIN INSULATOR -SMALL HEAD		
DESIGNATION	NAME	DATE
DRAFTSMAN		
DESIGNER		
DESIGN CHECK		
PROJECT MANAGER		
PROJECT DIRECTOR		
DRAWING NO. BPC-DDCS-2015-43/2		REVISION 2015

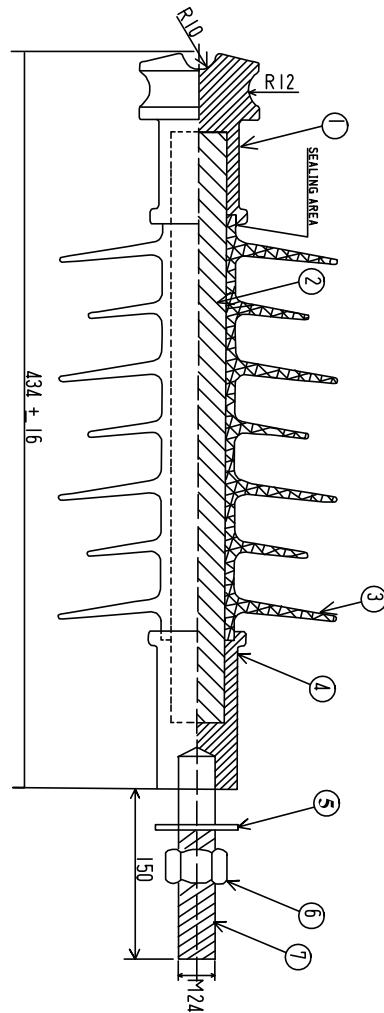

Sl.no	Description
1	Top Metal Fitting
2	Core Rod
3	Polymer Housing
4	Bottom Metal Fitting
5	Plain Washer
6	Nut
7	Stud

Guaranteed Technical Parameters

1. Min. Creepage Distance : 900 mm
2. Arcing Distance (Approximate) : 320 mm
3. Cantilever Failure Load : 10 kN
4. Nominal System Voltage : 33 kV
5. Highest System Voltage : 36 kV
6. System Frequency : 50 Hz
7. 1 Min. Power Freq. Withstand Voltage (Wet) : 75 kV (rms)
8. Dry Lightning Impulse Withstand Voltage : 170 kVp

 BHUTAN POWER CORPORATION LIMITED	ENGINEERING DESIGN & CONTRACTS DEPARTMENT	
	DISTRIBUTION DESIGN & CONSTRUCTION STANDARD	
DESIGNATION	NAME	DATE
DRAFTSMAN		
DESIGNER		
DESIGN CHECK		
PROJECT MANAGER		
PROJECT DIRECTOR		
DRAWING NO. BPC-DDCS-2015-44		REVISION 2015

Porcelain Disc Insulator

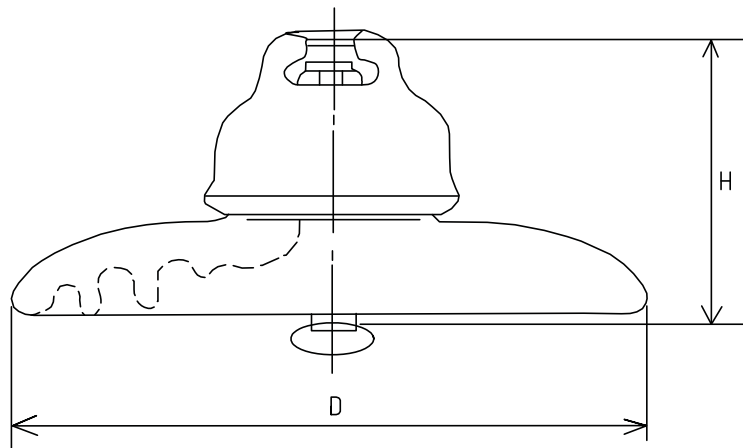

Item	Dimensions (mm)		Rate Failure Load (kN)	Weight (kg)
	D	H		
11kV	255	146	70	5.2
33kV	255	146	70	5.2x3

33 kV & 11 kV - 70 kN COMPOSITE SILICONE RUBBER LONG ROD INSULATOR

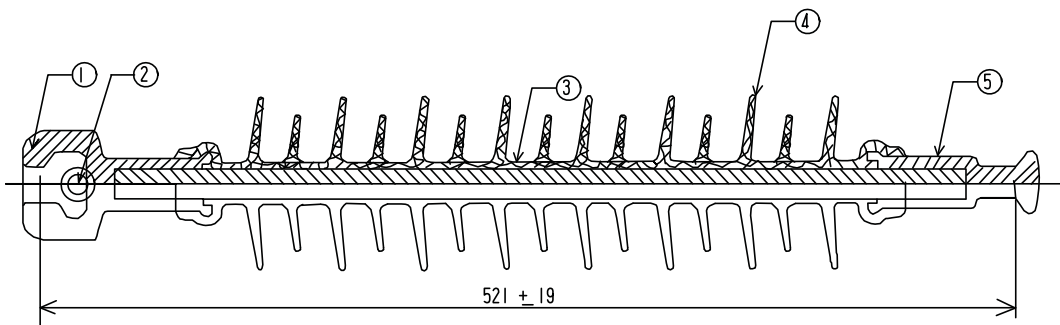

Sl.no	Description
1	Socket Fitting
2	Security clip (R)
3	Core Rod
4	Polymer Housing
5	Ball fitting



BHUTAN POWER CORPORATION LIMITED

ENGINEERING DESIGN & CONTRACTS DEPARTMENT

DISTRIBUTION DESIGN & CONSTRUCTION STANDARD

PORCELAIN AND COMPOSITE SILICON RUBBER DISC INSULATOR

DESIGNATION	NAME	DATE
DRAFTSMAN		
DESIGNER		
DESIGN CHECK		
PROJECT MANAGER		
PROJECT DIRECTOR		

DRAWING NO. BPC-DDCS-2015-45

REVISION
2015

SINGLE TENSION STRING

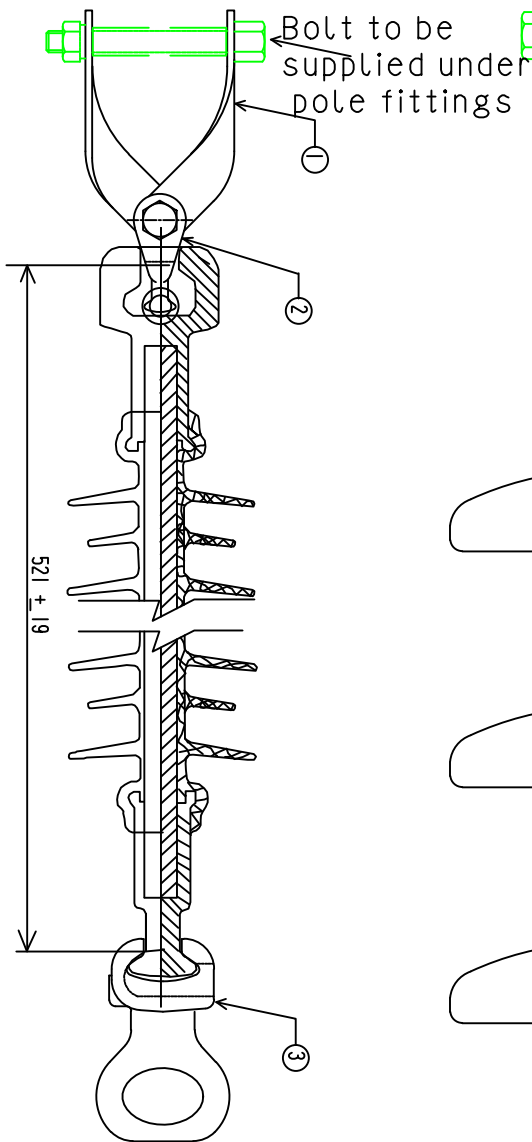

33 kV SINGLE TENSION STRING

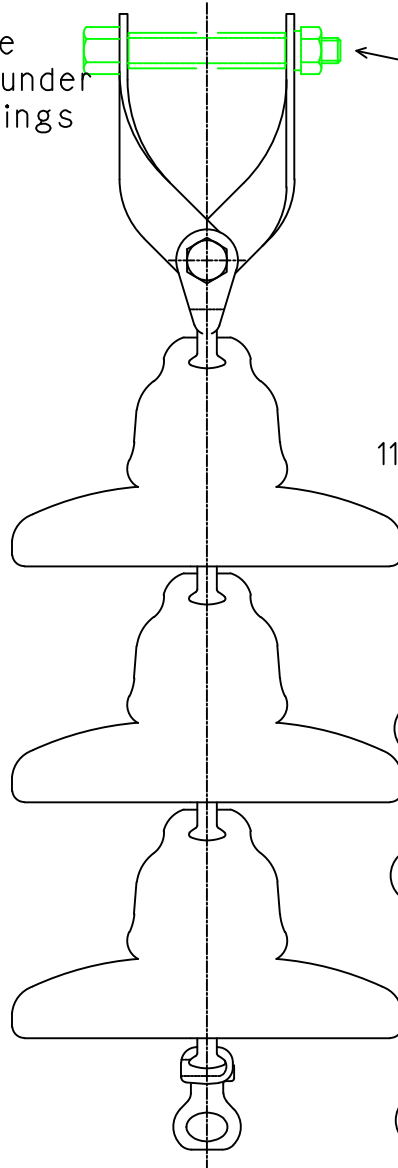
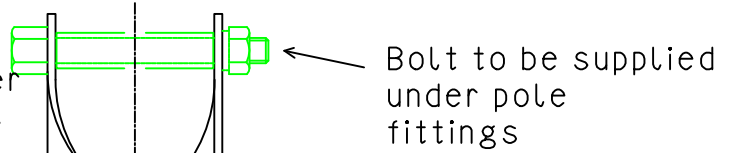

11 kV SINGLE TENSION STRING

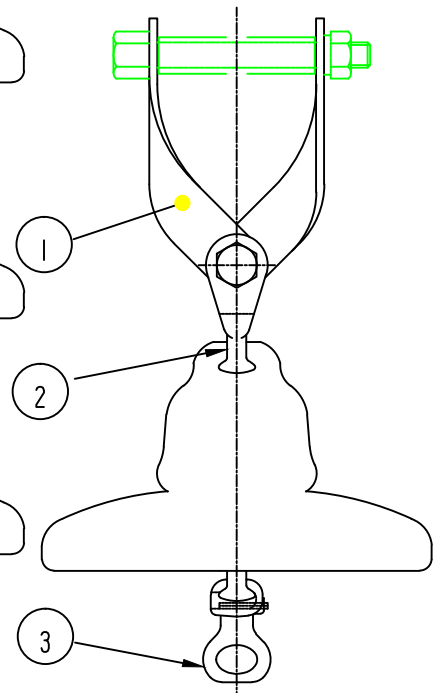

Notes:

1. All fittings shall be galvanised according to relevant standard

3	SOCKET THIMBLE	1	ALUMINIUM ALLOY
2	BALL EYE	1	FORGED STEEL
1	CROSSARM STRAP (TOGETHER, NOT SEPARATE)	1	GALVANISED IRON
ITEM	NAME OF ITEM	QTY	MATERIAL



BHUTAN POWER CORPORATION LIMITED

ENGINEERING DESIGN & CONTRACTS DEPARTMENT

DISTRIBUTION DESIGN & CONSTRUCTION STANDARD

ASSEMBLY FOR DISC INSULATOR ARRANGEMENT

DESIGNATION	NAME	DATE
DRAFTSMAN		
DESIGNER		
DESIGN CHECK		
PROJECT MANAGER		
PROJECT DIRECTOR		

DRAWING NO. BPC-DDCS-2015-46

REVISION
2015

CROSS ARM STRAP

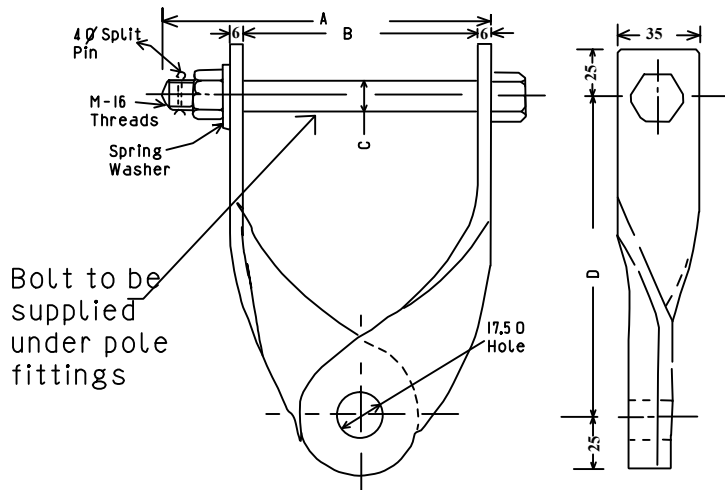

Dimensions (mm)				Rate Failure Load	Weight
A	B	C	D	(kN)	(kg)
145	100	16	140	70	-

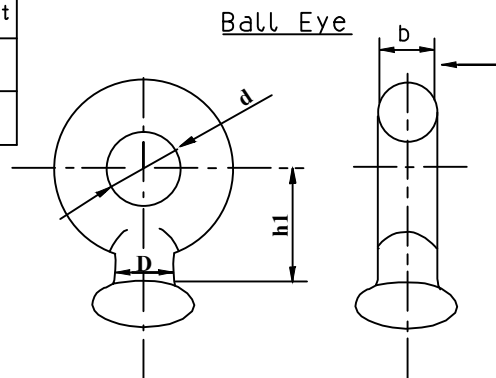

Dimensions (mm)				Rate Failure Load	Weight
D	h1	b	d	(kN)	(kg)
17	50	16	18	70	-

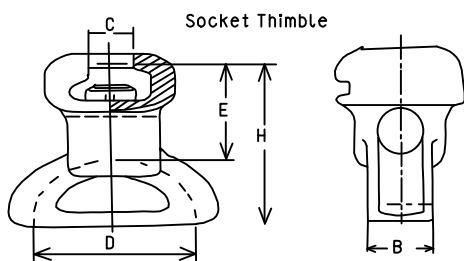

Dimensions (mm)					Rate Failure Load	Weight
B	C	D	E	H	(kN)	(kg)
32	17,6	60	60	95	70	1,20

Notes:

I. All fittings shall be galvanised according to relevant standard



BHUTAN POWER CORPORATION LIMITED

ENGINEERING DESIGN & CONTRACTS DEPARTMENT

DISTRIBUTION DESIGN & CONSTRUCTION STANDARD

HARDWARE FITTINGS FOR DISC INSULATOR ARRANGEMENT

DESIGNATION	NAME	DATE
DRAFTSMAN		
DESIGNER		
DESIGN CHECK		
PROJECT MANAGER		
PROJECT DIRECTOR		

DRAWING NO. BPC-DDCS-2015-47

REVISION
2015

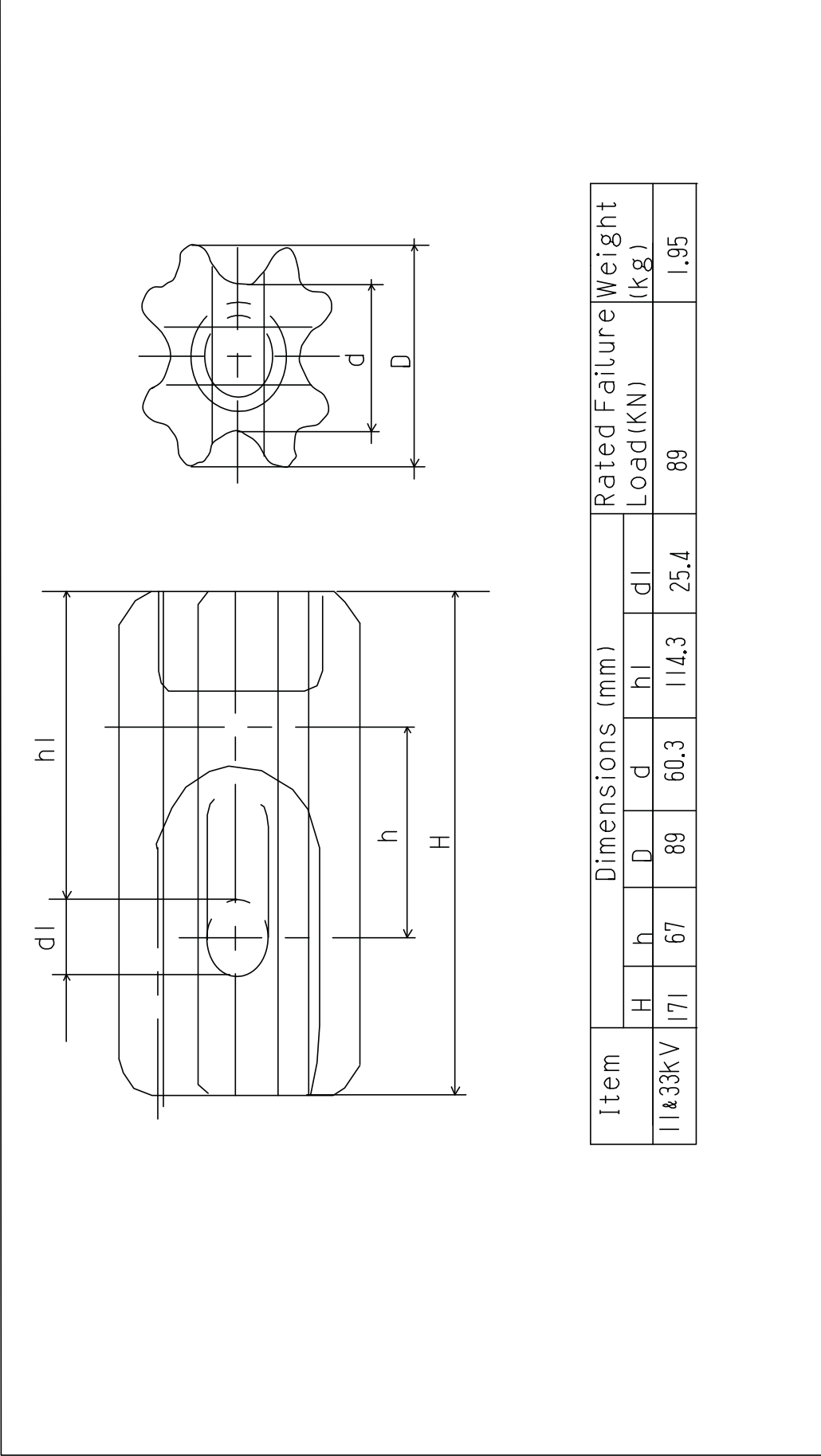

Item	Dimensions (mm)						Rated Failure Load(KN)	Weight (kg)
	H	h	D	d	h1	dl		
11 & 33kV	171	67	89	60.3	114.3	25.4	89	1.95

		BHUTAN POWER CORPORATION LIMITED		ENGINEERING DESIGN & CONTRACTS DEPARTMENT	
TITLE	NAME	DATE	DISTRIBUTION DESIGN & CONSTRUCTION STANDARD HT STAY INSULATOR		
DESIGNED BY			DRAWING NO. BPC-DDCS-2015-48		
CHECKED BY			REVISION 2015		
APPROVED BY					

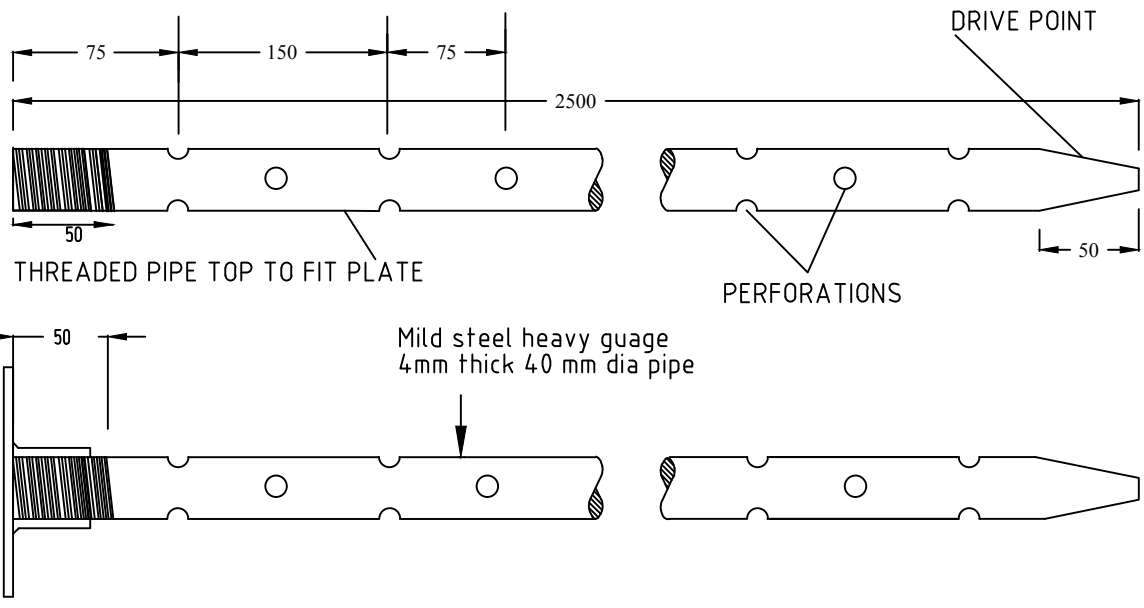

EARTH PLATE 250x250x6

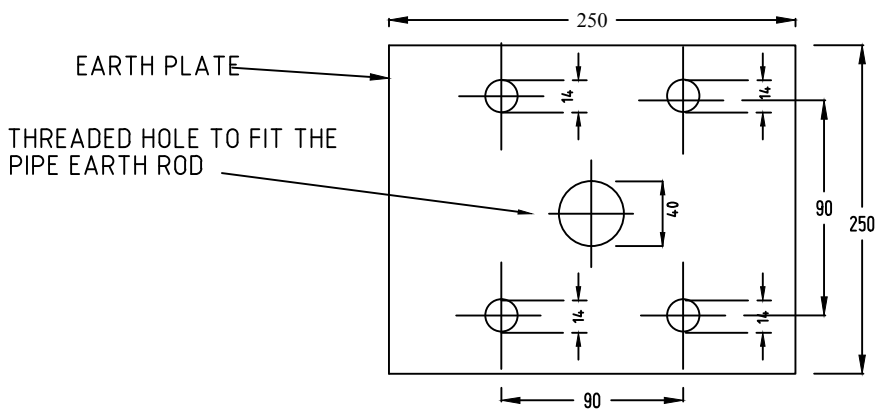

EARTHING FLAT 25X6 MM

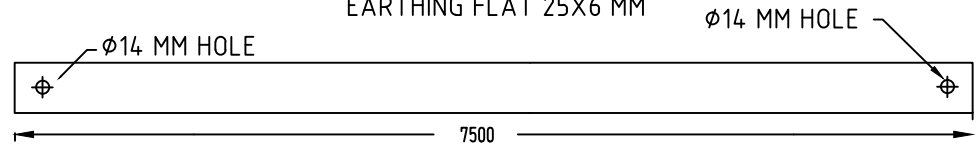

GRADE OF STEEL: BS 1387 OR EQUIVALENT
 GALVANISED TO: BS 729 OR EQUIVALENT
 PACKING: EARTING ROD,LUGS, BOLTS & NUTS
 & GI FLAT , PLATE PACKED SEPARATELY

EARTHING FLAT (6.5 METER)	11	H.D.G STEEL
FLANGED PLATE	1	H.D.G STEEL
SPRING WASHER	4	H.D.G STEEL
HEX NUT M06	4	H.D.G STEEL
HEX BOLT M06X25	4	H.D.G STEEL
EARTHING ROD	1	H.D.G STEEL
NAME OF THE ITEM	QTY	MATERIAL

 <p>BHUTAN POWER CORPORATION LIMITED</p>	ENGINEERING DESIGN & CONTRACTS DEPARTMENT	
	DISTRIBUTION DESIGN & CONSTRUCTION STANDARD	
PIPE EARTHING		
DESIGNATION	NAME	DATE
DRAFTSMAN		
DESIGNER		
DESIGN CHECK		
PROJECT MANAGER		
PROJECT DIRECTOR		
DRAWING NO. BPC-DDCS-2015-50		REVISION
		2015

ANCHOR ROD ASSEMBLY

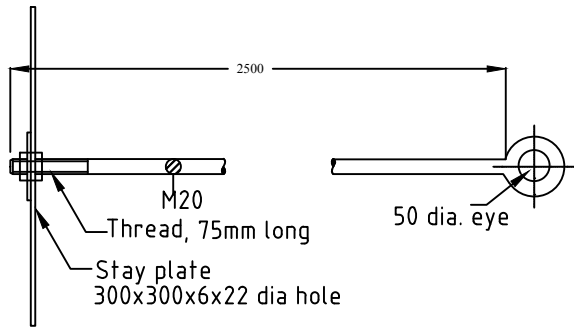

TURN-BUCKLE ASSEMBLY

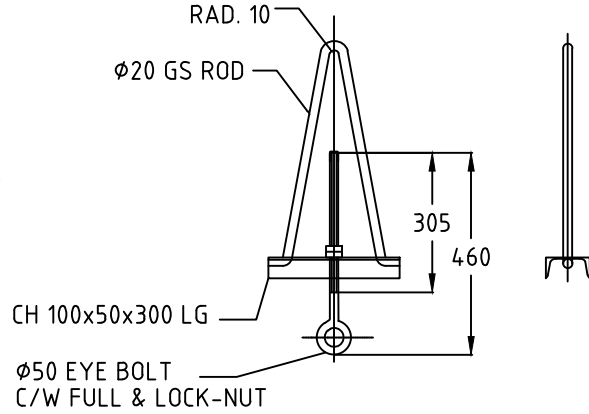

STAY PLATE

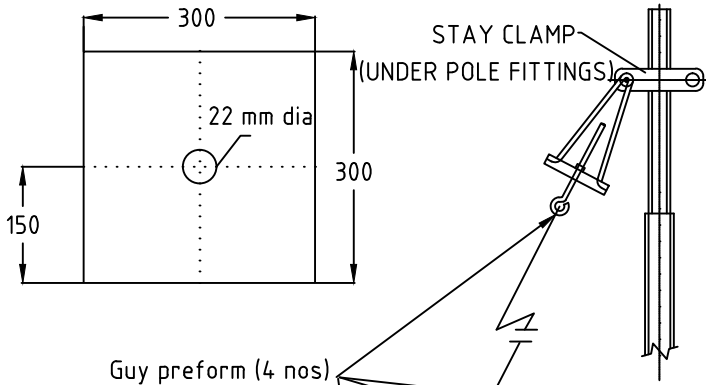

EYE BOLT

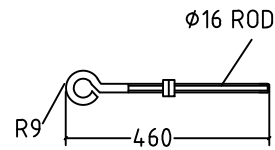

V HANGER

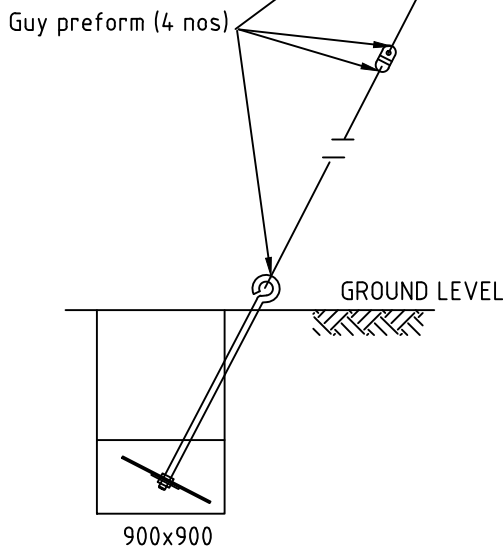
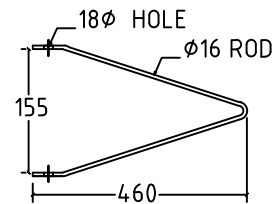

STAY WIRE ASSEMBLY

NOTES

- Stay rod and nuts assembled and packed together
- Anchor plates packed separately
- Material :- BS 4360 Grade 43A
- Galvanizing :- BS 729
- Threads :- ISO Metric
- Nut :- BS 4190 Grade 4.0

NAME OF THE ITEM	QTY	MATERIAL
V-HANGER ONLY FOR TELESCOPIC POLE	1	H.D.G STEEL
STAY WIRE (7/8 SWG) (IN METERS)	1M+POLE HEIGHT	H.D.G STEEL
STAY CLAMP WITH NUTS AND BOLTS	1	H.D.G STEEL
STAY ROD (2.5 M) WITH THIMBLE	1	H.D.G STEEL
ANCHOR PLATE (300 X 300 X 6MM)	1	H.D.G STEEL
TURN BUCKLE ASSEMBLY WITH THIMBLE	1	H.D.G STEEL
GUY PREFORMED SUITABLE FOR 7/8 SWG	4	GALVANISED STEEL WIRE
STAY INSULATOR	1	PORCELAIN



BHUTAN POWER CORPORATION LIMITED

ENGINEERING DESIGN & CONTRACTS DEPARTMENT

DISTRIBUTION DESIGN & CONSTRUCTION STANDARD

STAY SET ASSEMBLY

DESIGNATION	NAME	DATE
DRAFTSMAN		
DESIGNER		
DESIGN CHECK		
PROJECT MANAGER		
PROJECT DIRECTOR		

DRAWING NO. BPC-DDCS-2015-51

REVISION 2015

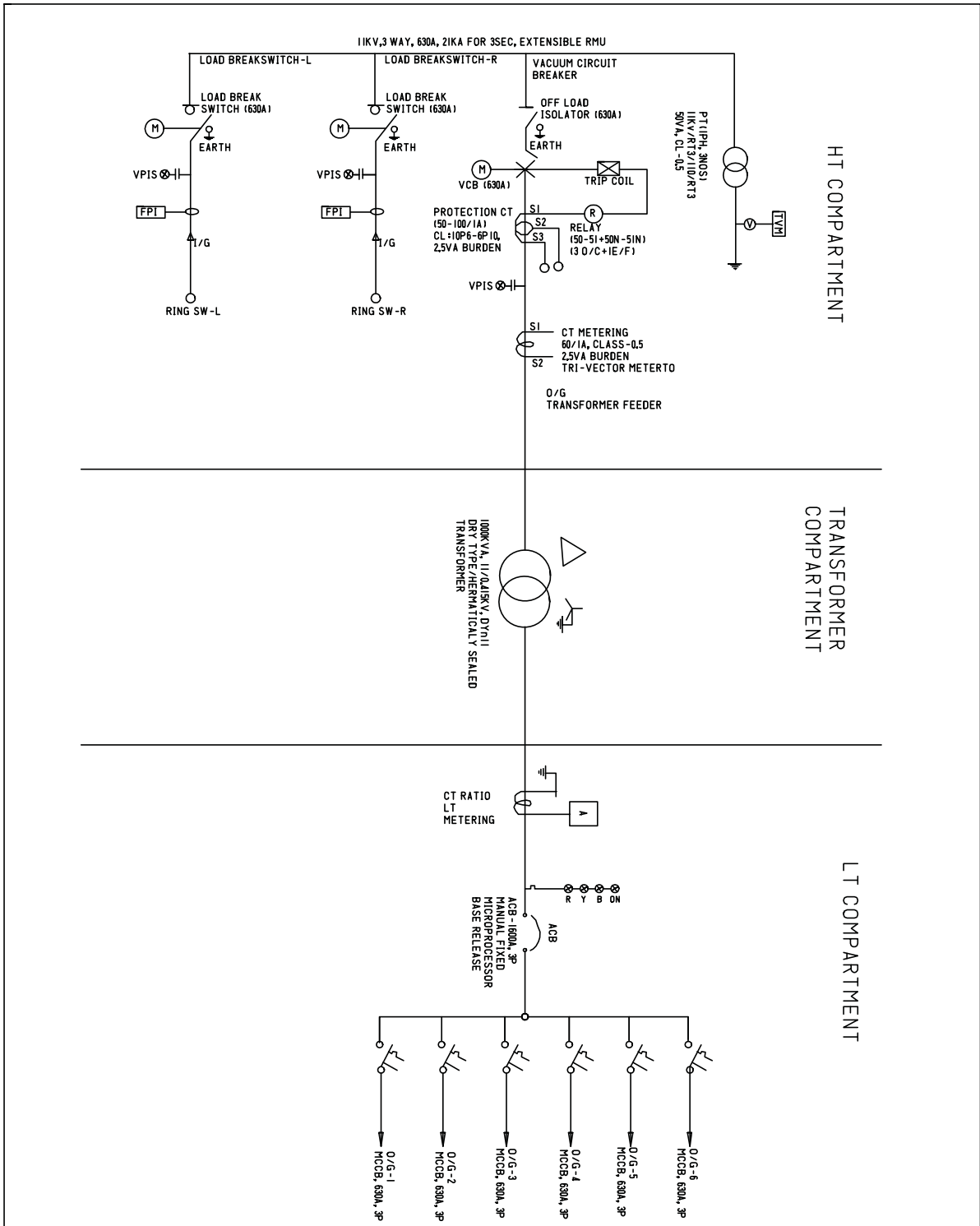

 BHUTAN POWER CORPORATION LIMITED			ENGINEERING DESIGN & CONTRACTS DEPARTMENT																			
			TITLE : DISTRIBUTION DESIGN & CONSTRUCTION STANDARD																			
<table border="1"> <tr> <td>DESIGNATION</td> <td>NAME</td> <td>DATE</td> </tr> <tr> <td>DRAFTSMAN</td> <td></td> <td></td> </tr> <tr> <td>DESIGNER</td> <td></td> <td></td> </tr> <tr> <td>DESIGN CHECK</td> <td></td> <td></td> </tr> <tr> <td>PROJECT MANAGER</td> <td></td> <td></td> </tr> <tr> <td>PROJECT DIRECTOR</td> <td></td> <td></td> </tr> </table>			DESIGNATION	NAME	DATE	DRAFTSMAN			DESIGNER			DESIGN CHECK			PROJECT MANAGER			PROJECT DIRECTOR			GENERAL ARRANGEMENT OF 4WAYS UNITIZED SUBSTATION	
			DESIGNATION	NAME	DATE																	
			DRAFTSMAN																			
			DESIGNER																			
			DESIGN CHECK																			
PROJECT MANAGER																						
PROJECT DIRECTOR																						
			DRAWING NO. BPC-DDCS-2015-52																			
			REVISION 2015																			

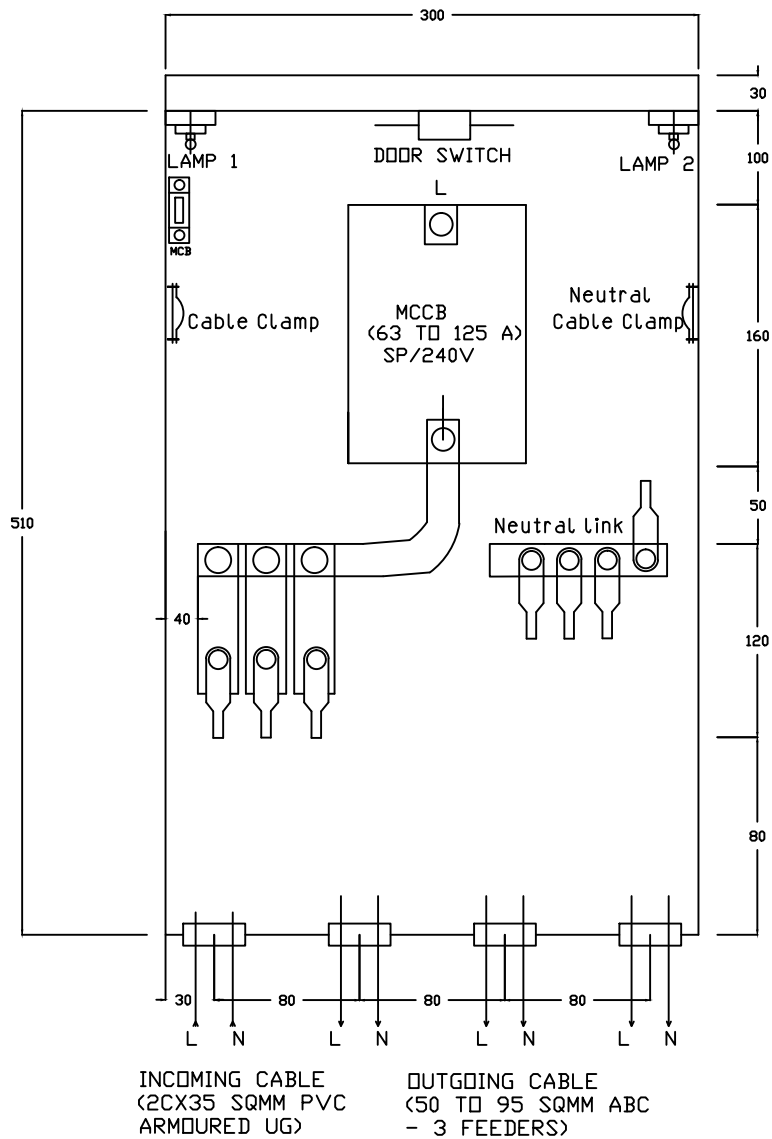

INTERNAL WIRING DIAGRAM OF DISTRIBUTION PILLAR

NOTES

INNER DEVICE :

MCCB : RATING UPTO 160 A, SPN, I NO.

HRC FUSES : RATING UPTO 100 A - 3 NOS / 2NOS DEPENDING ON NUMBER OF WAYS.

DIMENSIONS AS SHOWN ARE IN MM.

TO BE USED WITH 10 KVA, 16KVA AND 25KVA SINGLE PHASE TRANSFORMER RATINGS

CABLE LUG TO BE SUPPLIED FIXED WITH THE BOARD FOR APPROPRIATE CABLE SIZES.

	BHUTAN POWER CORPORATION LIMITED	ENGINEERING DESIGN & CONTRACTS DEPARTMENT	
	TITLE : DISTRIBUTION DESIGN & CONSTRUCTION STANDARD		
SINGLE PHASE TRANSFORMER LT PANEL, 3 WAYS, INCOMER MCCB - UPTO 160 A, OUTGOING HRC FUSE UPTO 100 A (INTERNAL VIEW)			
DESIGNATION	NAME	DATE	DRAWING NO. BPC-DDCS-2015-53/1
DRAFTSMAN			
DESIGNER			
DESIGN CHECK			
PROJECT MANAGER			
PROJECT DIRECTOR			
			REVISION 2015

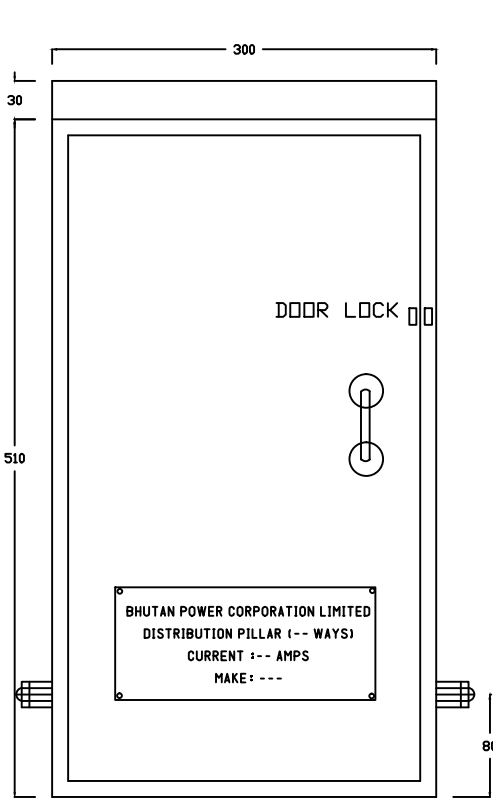

FRONT VIEW

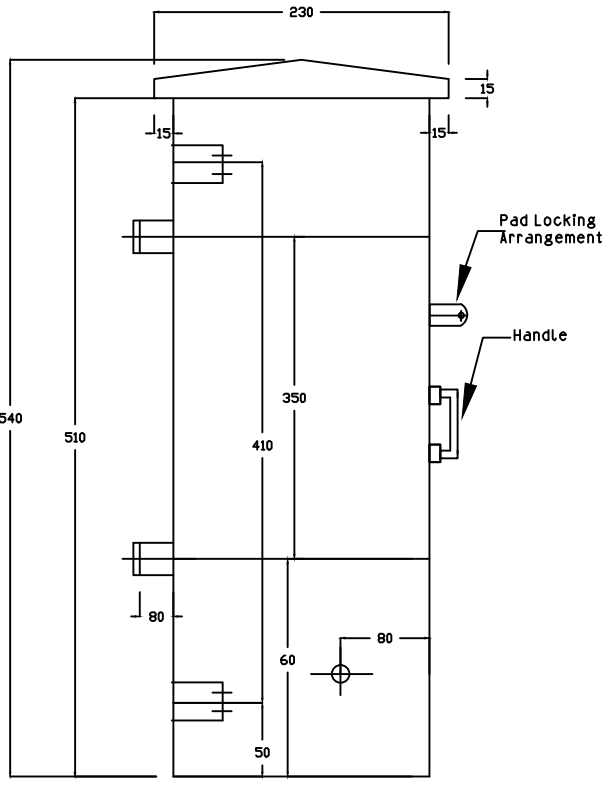

SIDE VIEW

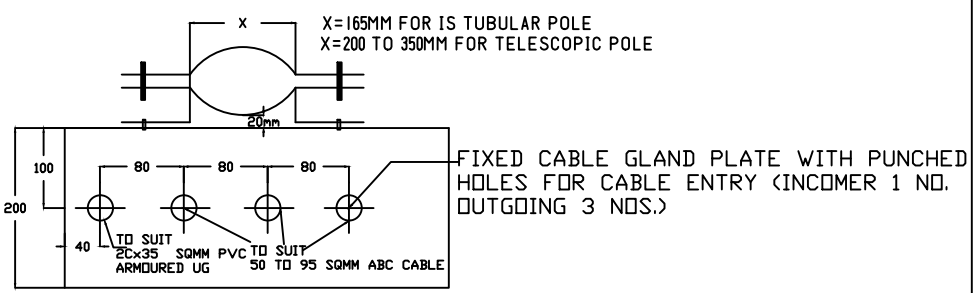

BOTTOM VIEW

NOTE:

MCCB RATING	PHASE BUSBAR SIZE	NEUTRAL BUSBAR SIZE
63A	12X6MM AL.ALLOY, GR-E91E	12X3MM AL.ALLOY, GR-E91E
100A	12X8MM AL.ALLOY, GR-E91E	12X4MM AL.ALLOY, GR-E91E
125A	19X6MM AL.ALLOY, GR-E91E	19X3MM AL.ALLOY, GR-E91E
160A	19X8MM AL.ALLOY, GR-E91E	19X4MM AL.ALLOY, GR-E91E

BAYONET LAMP (1 NO.) TO BE PROVIDED



BHUTAN POWER CORPORATION LIMITED

ENGINEERING DESIGN & CONTRACTS DEPARTMENT

TITLE : DISTRIBUTION DESIGN & CONSTRUCTION STANDARD

SINGLE PHASE TRANSFORMER LT PANEL, 3 WAYS, INCOMER MCCB- UPTO 160 A, OUTGOING HRC FUSE UPTO 100 A (EXTERNAL VIEW)

DESIGNATION	NAME	DATE
DRAFTSMAN		
DESIGNER		
DESIGN CHECK		
PROJECT MANAGER		
PROJECT DIRECTOR		

DRAWING NO. BPC-DDCS-2015-53/2

REVISION
2015

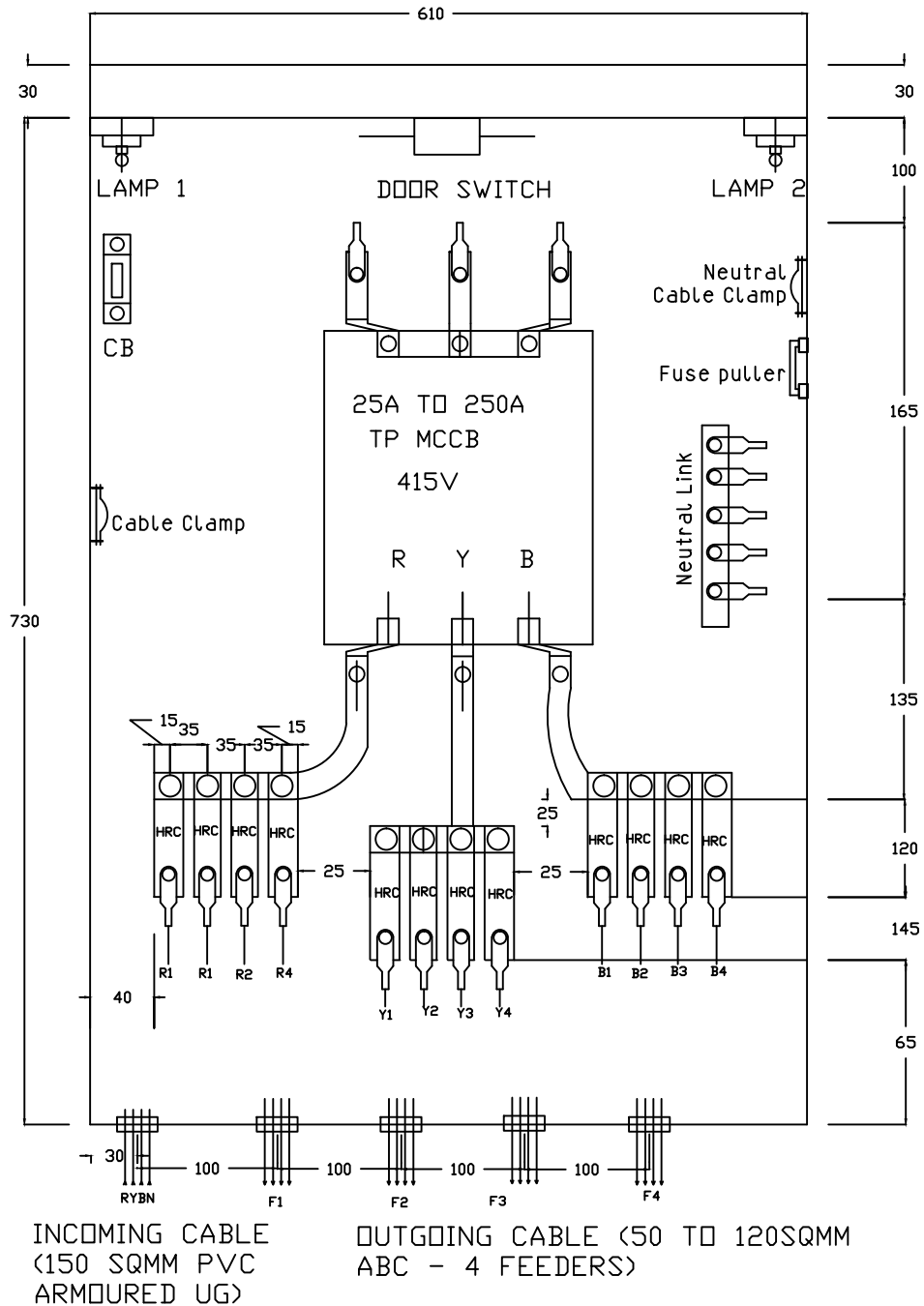

NOTES

INTERNAL WIRING DIAGRAM OF DISTRIBUTION PILLAR

INNER DEVICE:

MCCB UPTO 250A, 1NO, TPN-415V

HRC FUSES: UPTO 125A, 6 NOS/12NOS DEPENDING ON NUMBER OF WAYS

Provide one number of HRC fuse puller for every board.

TO BE USED WITH 16KVA, 25KVA, 63 kVA and 125 kVA 3PHASE TRANSFORMER RATINGS

CABLE LUG TO BE SUPPLIED FIXED WITH THE BOARD FOR APPROPRIATE CABLE SIZES.

 <p>BHUTAN POWER CORPORATION LIMITED</p>	ENGINEERING DESIGN & CONTRACTS DEPARTMENT	
	TITLE : DISTRIBUTION DESIGN & CONSTRUCTION STANDARD	
THREE PHASE TRANSFORMER LT PANEL, 4 WAYS, INCOMER MCCB-UPTO 250A, OUTGOING HRC FUSE UPTO 125A (INTERNAL VIEW)		
DESIGNATION	NAME	DATE
DRAFTSMAN		
DESIGNER		
DESIGN CHECK		
PROJECT MANAGER		
PROJECT DIRECTOR		
DRAWING NO. BPC-DDCS-2015-54/1		REVISION 2015

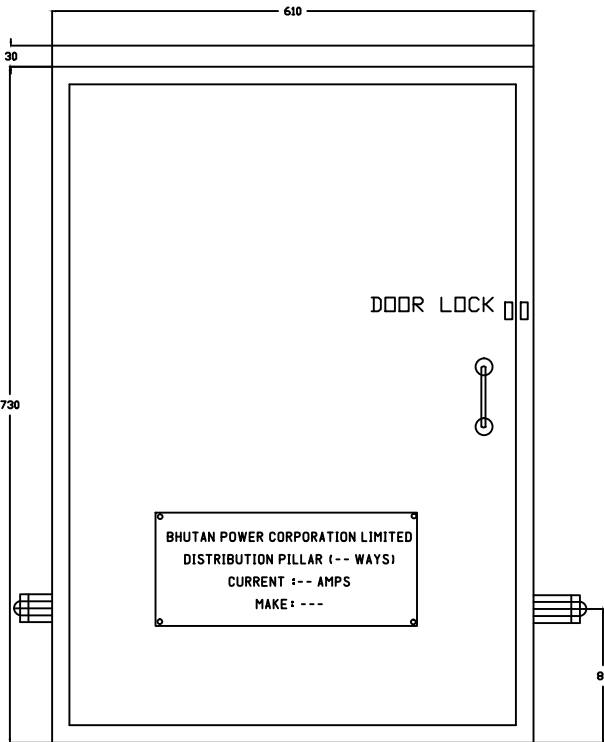

FRONT VIEW

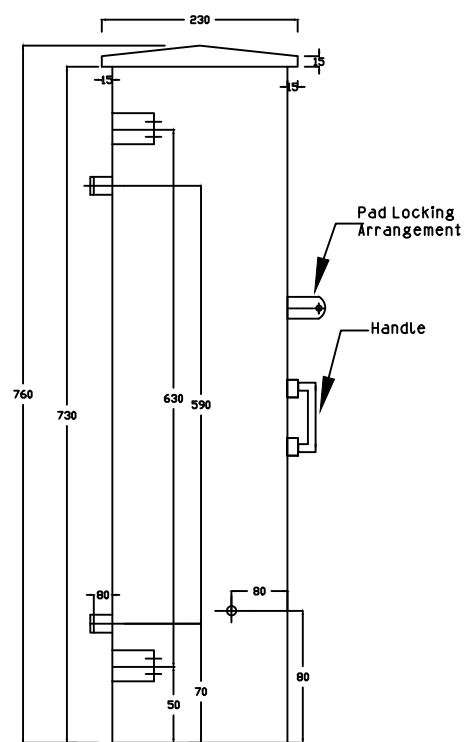

SIDE VIEW

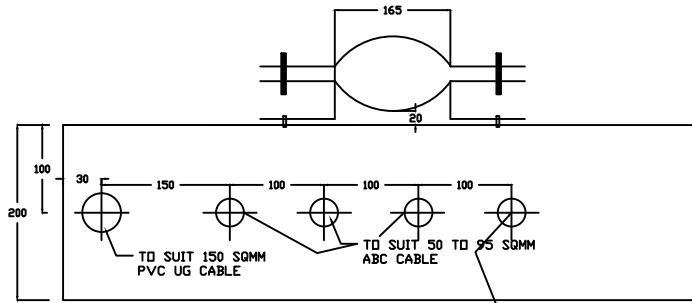

BOTTOM VIEW

FIXED CABLE GLAND PLATE WITH PUNCHED HOLES FOR CABLE ENTRY (OUTGOING 4 NOS) AND (INCOMING 1ND)

NOTE:
 BUSBAR SIZE 25x10MM AL / 20x3MM CU
 NEUTRAL BUSBAR 25x5MM AL / 20x3MM CU
 BAYONET LAMP (IND) TO BE PROVIDED



BHUTAN POWER CORPORATION LIMITED

ENGINEERING DESIGN & CONTRACTS DEPARTMENT

TITLE : DISTRIBUTION DESIGN & CONSTRUCTION STANDARD

THREE PHASE TRANSFORMER LT PANEL, 4 WAYS, INCOMER MCCB - UPTO 250A, OUTGOING HRC FUSE UPTO 125A (EXTERNAL VIEW)

DESIGNATION	NAME	DATE
DRAFTSMAN		
DESIGNER		
DESIGN CHECK		
PROJECT MANAGER		
PROJECT DIRECTOR		

DRAWING NO. BPC-DDCS-2015-54/2

REVISION
2015

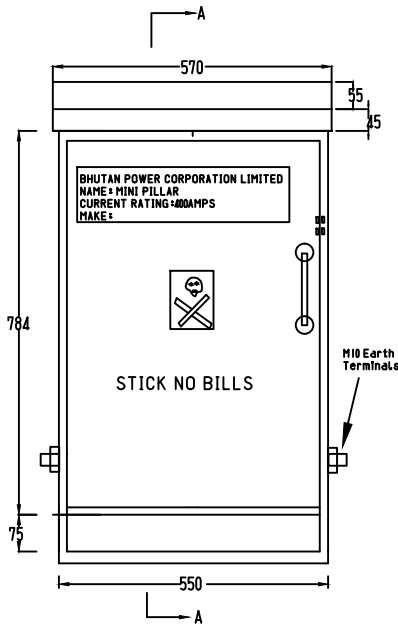

FRONT ELEVATION

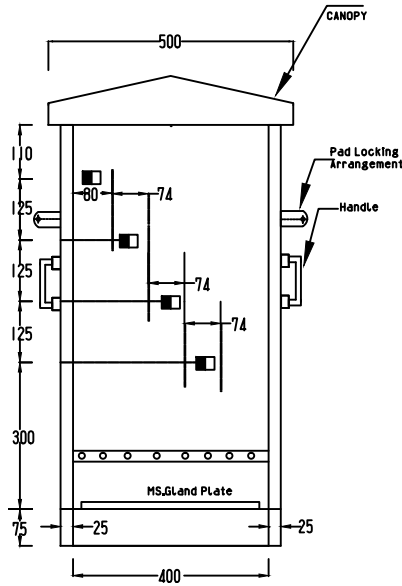

SIDE ELEVATION: (A:A)

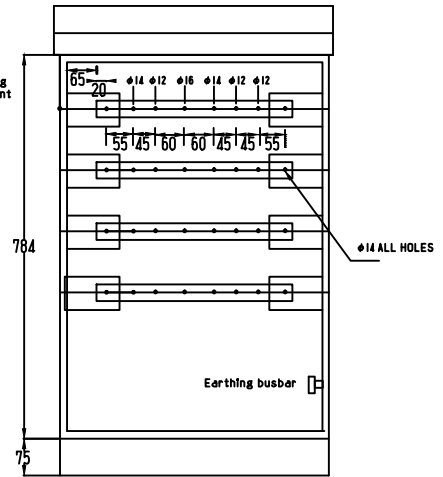

FRONT ELEVATION WITHOUT DOOR

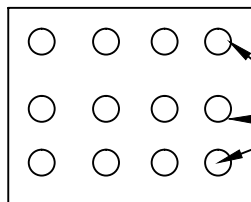

GLAND PLATE DETAILS

PUNCH HOLES FOR CABLE ENTRY VARIOUS SIZE OF CABLES FROM 16SQ.MM TO 300SQ.MM

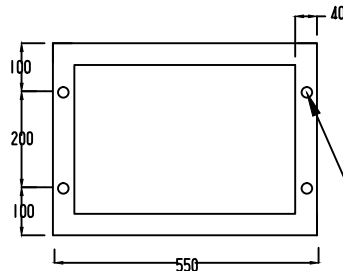

FOUNDATION PLAN

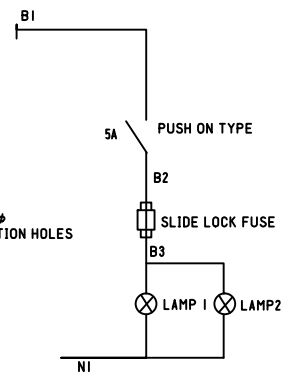

PHASE BUSBAR - 1X6X50MM AL. ALLOY
 NEUTRAL - 1X6X50MM ALALLOY.
 MATERIAL - THE FEEDER PILLAR (INCLUDING BASE CHANNEL SHALL BE FABRICATED OUT OF 2.5MM MS SHEET
 PAINT - SIEMENS GREY (OUTSIDE) & WHITE (INSIDE)
 EARTH BUSBAR - 1X6X19MM AL. ALLOY.

NOTES

1. DIMENSIONS AS SHOWN ARE IN MM.
2. DRAWING NOT TO SCALE.



BHUTAN POWER CORPORATION LIMITED

ENGINEERING DESIGN & CONTRACTS DEPARTMENT

TITLE : DISTRIBUTION DESIGN & CONSTRUCTION STANDARD

MINI FEEDER PILLAR 400AMPS

DESIGNATION	NAME	DATE
DRAFTSMAN		
DESIGNER		
DESIGN CHECK		
PROJECT MANAGER		
PROJECT DIRECTOR		

DRAWING NO. BPC - DDCS - 2015 - 55

REVISION
2015

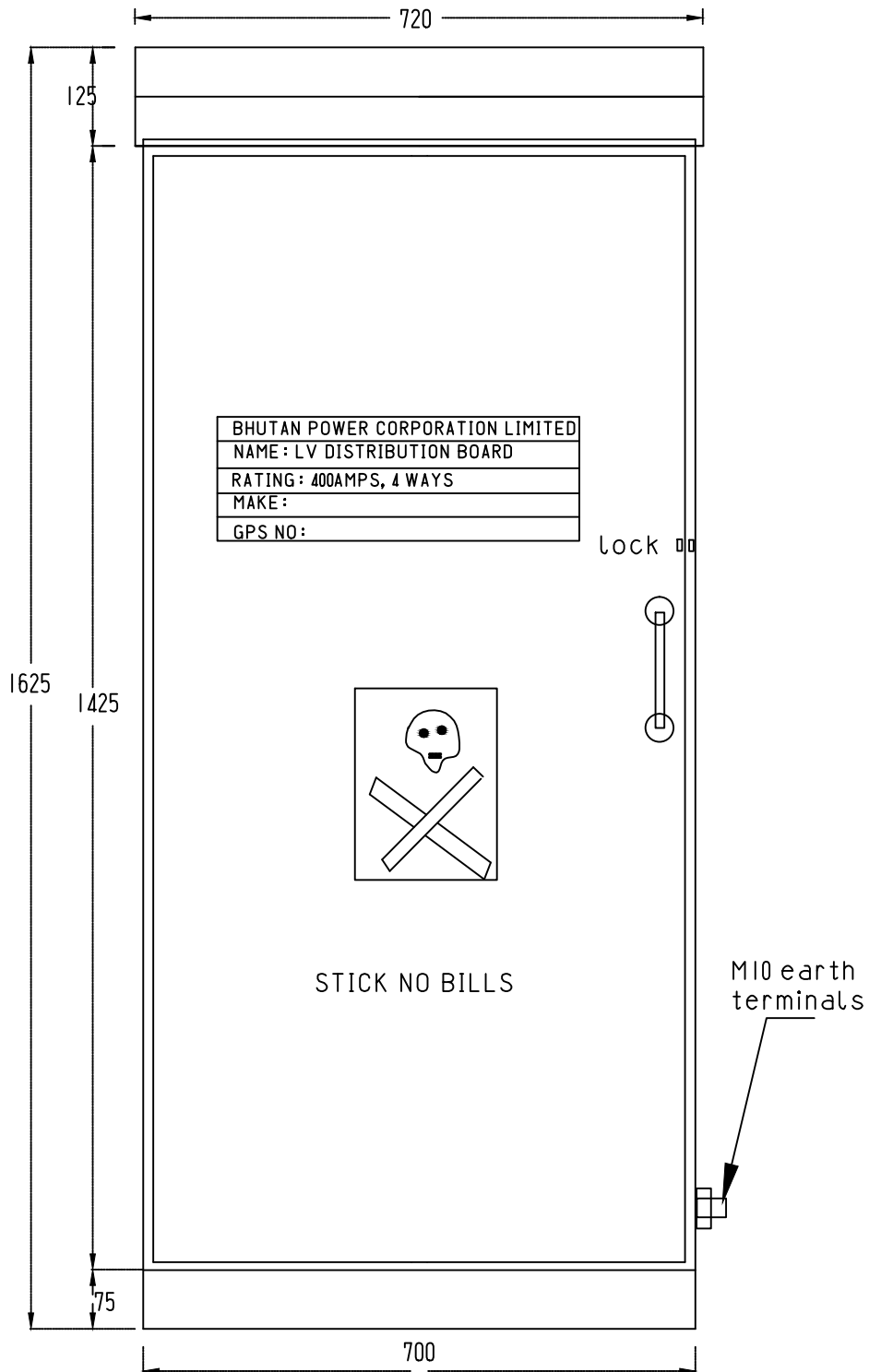

NOTES

1. DIMENSIONS AS SHOWN ARE IN MM.
2. DRAWING NOT TO SCALE.

 <p style="text-align: center;">BHUTAN POWER CORPORATION LIMITED</p>	ENGINEERING DESIGN & CONTRACTS DEPARTMENT	
	TITLE : DISTRIBUTION DESIGN & CONSTRUCTION STANDARD	
4WAYS TRANSFORMER DISTRIBUTION PILLAR (FRONT ELEVATION)		
DESIGNATION	NAME	DATE
DRAFTSMAN		
DESIGNER		
DESIGN CHECK		
PROJECT MANAGER		
PROJECT DIRECTOR		
DRAWING NO. BPC -DDCS -2015-56/1		REVISION 2015

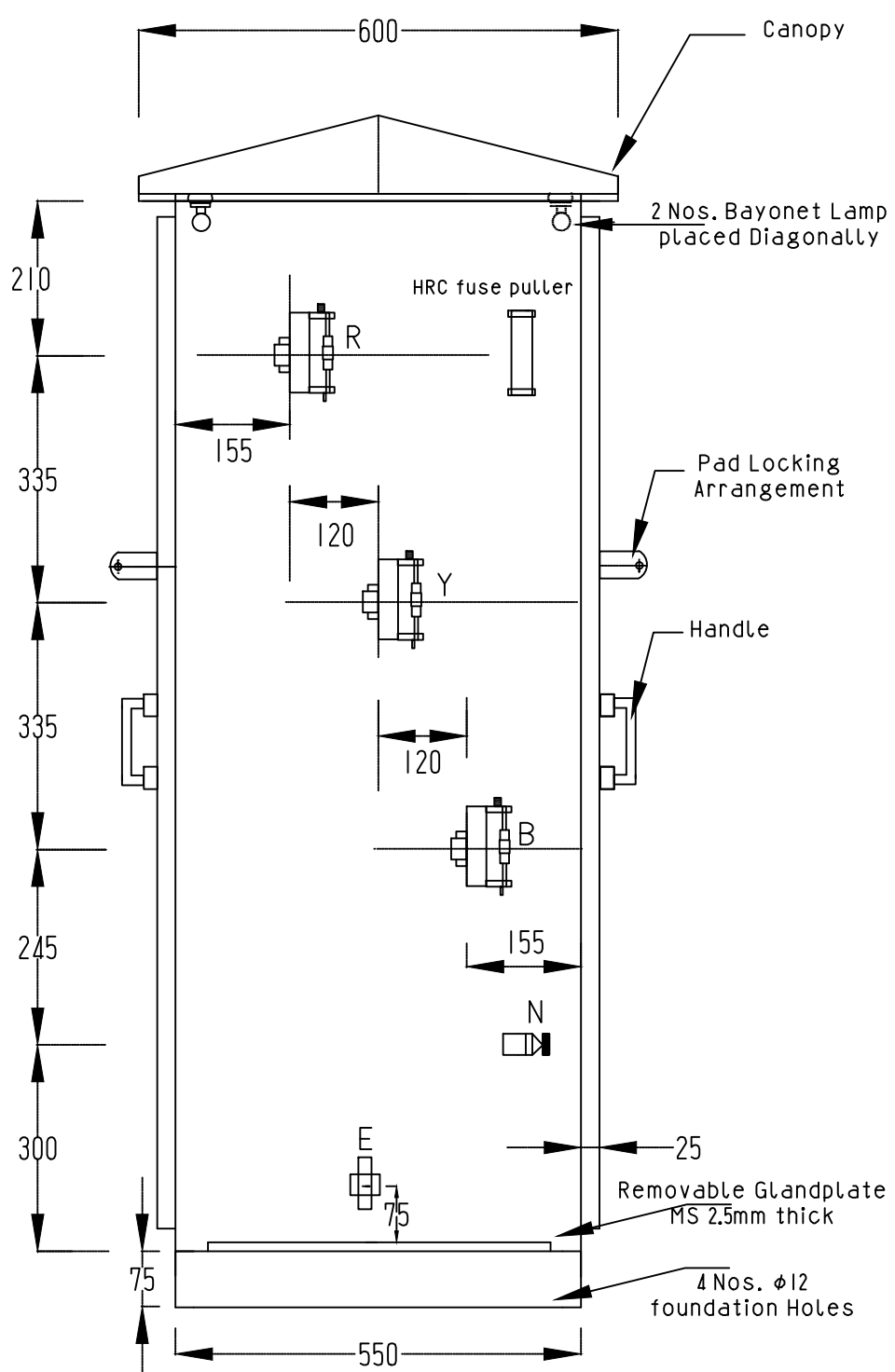

NOTES

1. DIMENSIONS AS SHOWN ARE IN MM. THE PILLAR SHALL BE TWO SIDED DOORS
2. DRAWING NOT TO SCALE.

	BHUTAN POWER CORPORATION LIMITED		ENGINEERING DESIGN & CONTRACTS DEPARTMENT	
			TITLE : DISTRIBUTION DESIGN & CONSTRUCTION STANDARD	
		4WAYS TRANSFORMER DISTRIBUTION PILLAR (SIDE ELEVATION)		
DESIGNATION	NAME	DATE	DRAWING NO. BPC -DDCS -2015-56/2	REVISION 2015
DRAFTSMAN				
DESIGNER				
DESIGN CHECK				
PROJECT MANAGER				
PROJECT DIRECTOR				

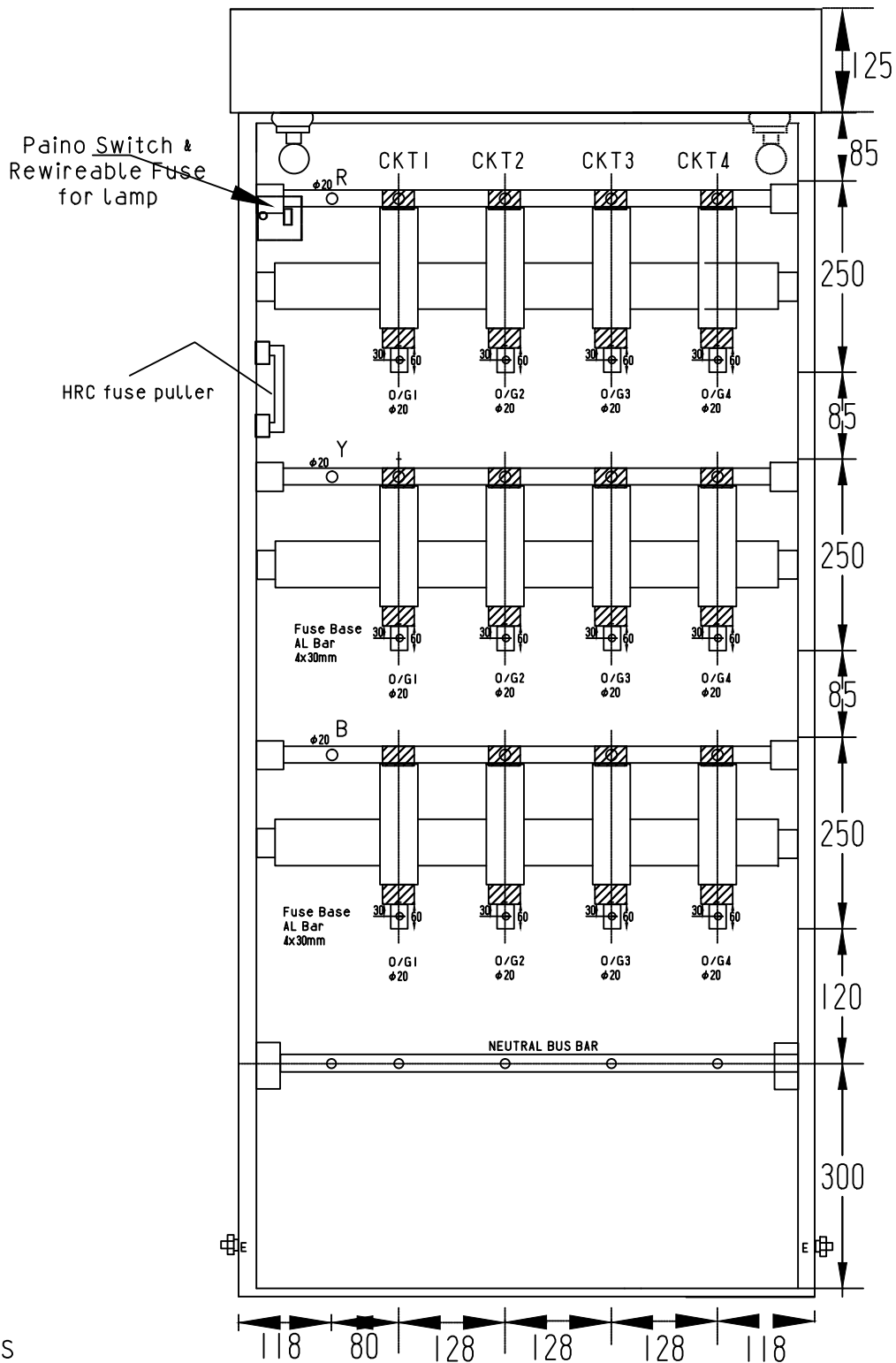

NOTES

1. DIMENSIONS AS SHOWN ARE IN MM.
2. PROVIDE ONE NO. OF FUSE PULLER FOR EVERY DISTRIBUTION BOARD.



BHUTAN POWER CORPORATION LIMITED

ENGINEERING DESIGN & CONTRACTS DEPARTMENT

TITLE : DISTRIBUTION DESIGN & CONSTRUCTION STANDARD

4WAYS TRANSFORMER DISTRIBUTION PILLAR
(FRONT ELEVATION WITHOUT DOOR)

DESIGNATION	NAME	DATE
DRAFTSMAN		
DESIGNER		
DESIGN CHECK		
PROJECT MANAGER		
PROJECT DIRECTOR		

DRAWING NO. BPC-DDCS-2015-56/3

REVISION
2015

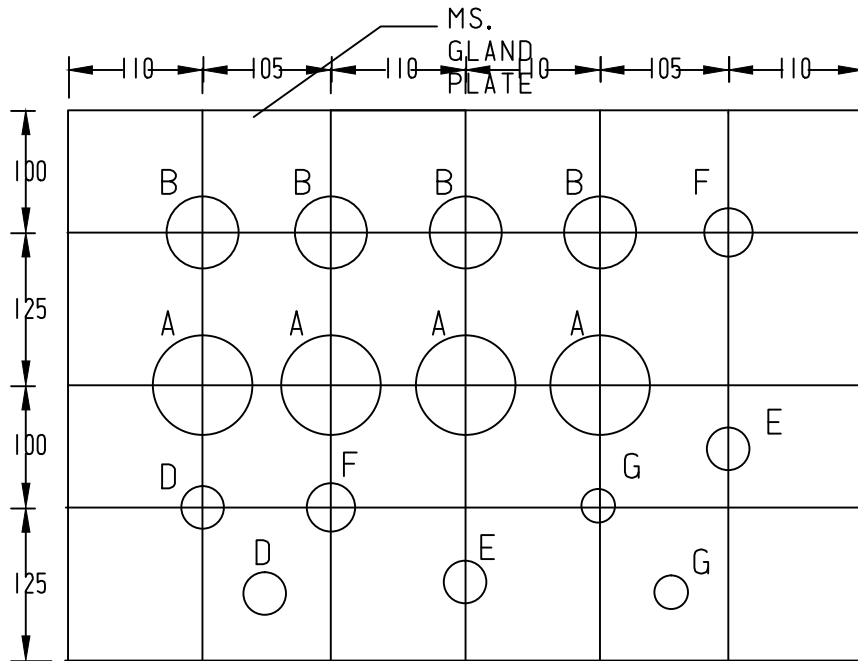

MS. GLAND PLATE	HOLE SIZE
A - 4CX400SQ.MM - KNOCKOUT	3-1/8"
B - 4CX300SQ.MM - KNOCKOUT	2-3/4"
C - 2CX16SQ.MM	1"
D - 4CX50SQ.MM - KNOCKOUT	1-1/2"
E - 4CX150SQ.MM - KNOCKOUT	2"
F - 4CX240SQ.MM - KNOCKOUT	2-1/2"
G - 4CX95SQ.MM - KNOCKOUT	1-3/4"
h - 2CX6SQ.MM	3/4"
I - 2CX10SQ.MM	1"

NOTES

1. DIMENSIONS AS SHOWN ARE IN MM.
2. DRAWING NOT TO SCALE.
3. CORRECT CABLE GLAND SIZE TO BE USED ACCORDINGLY WITH CABLE SIZE



BHUTAN POWER CORPORATION LIMITED

ENGINEERING DESIGN & CONTRACTS DEPARTMENT

TITLE : DISTRIBUTION DESIGN & CONSTRUCTION STANDARD

**4WAYS TRANSFORMER DISTRIBUTION PILLAR
(GLAND PLATE DETAILS)**

DESIGNATION	NAME	DATE
DRAFTSMAN		
DESIGNER		
DESIGN CHECK		
PROJECT MANAGER		
PROJECT DIRECTOR		

DRAWING NO. BPC-DDCS-2015-56/4

REVISION
2015

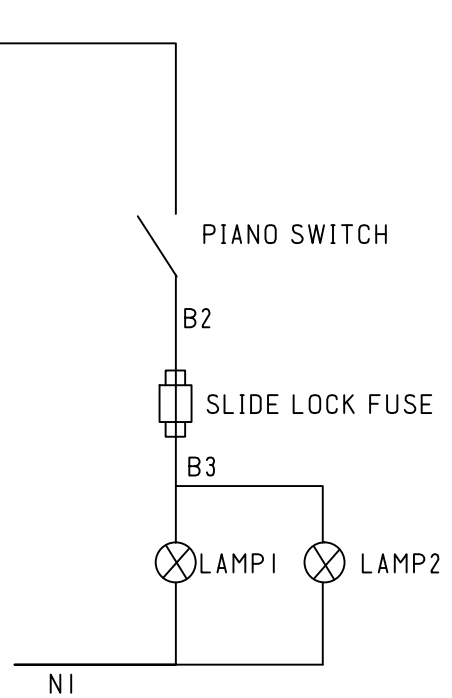
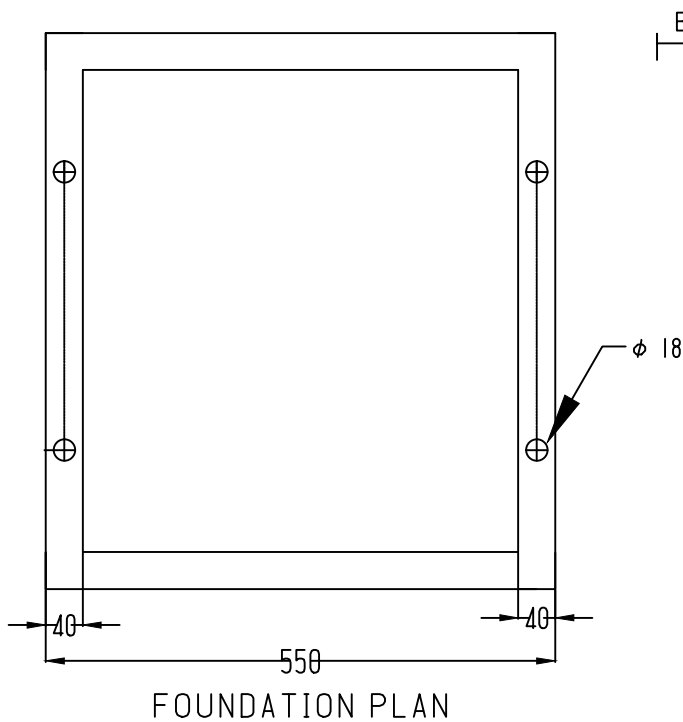

NOTES:
 PHASE - 50X6MM AL - 3NOS.
 NEUTRAL - 50X6MM AL - 1 NO. MATERIAL - THE FEEDER PILLAR (INCLUDING BASE CHANNEL) SHALL BE FABRICATED OUT OF 2.5MM MS SHEET.
 PAINT - SEIMENS GREY.
 EARTH - 1X6X19MM, AL ALLOY.



BHUTAN POWER CORPORATION LIMITED

ENGINEERING DESIGN & CONTRACTS DEPARTMENT

TITLE : DISTRIBUTION DESIGN & CONSTRUCTION STANDARD

4WAYS TRANSFORMER DISTRIBUTION PILLAR
(FOUNDATION DETAILS AND LIGHTING CKT)

DESIGNATION	NAME	DATE
DRAFTSMAN		
DESIGNER		
DESIGN CHECK		
PROJECT MANAGER		
PROJECT DIRECTOR		

DRAWING NO. BPC-DDCS -2015-56/5

REVISION
2015

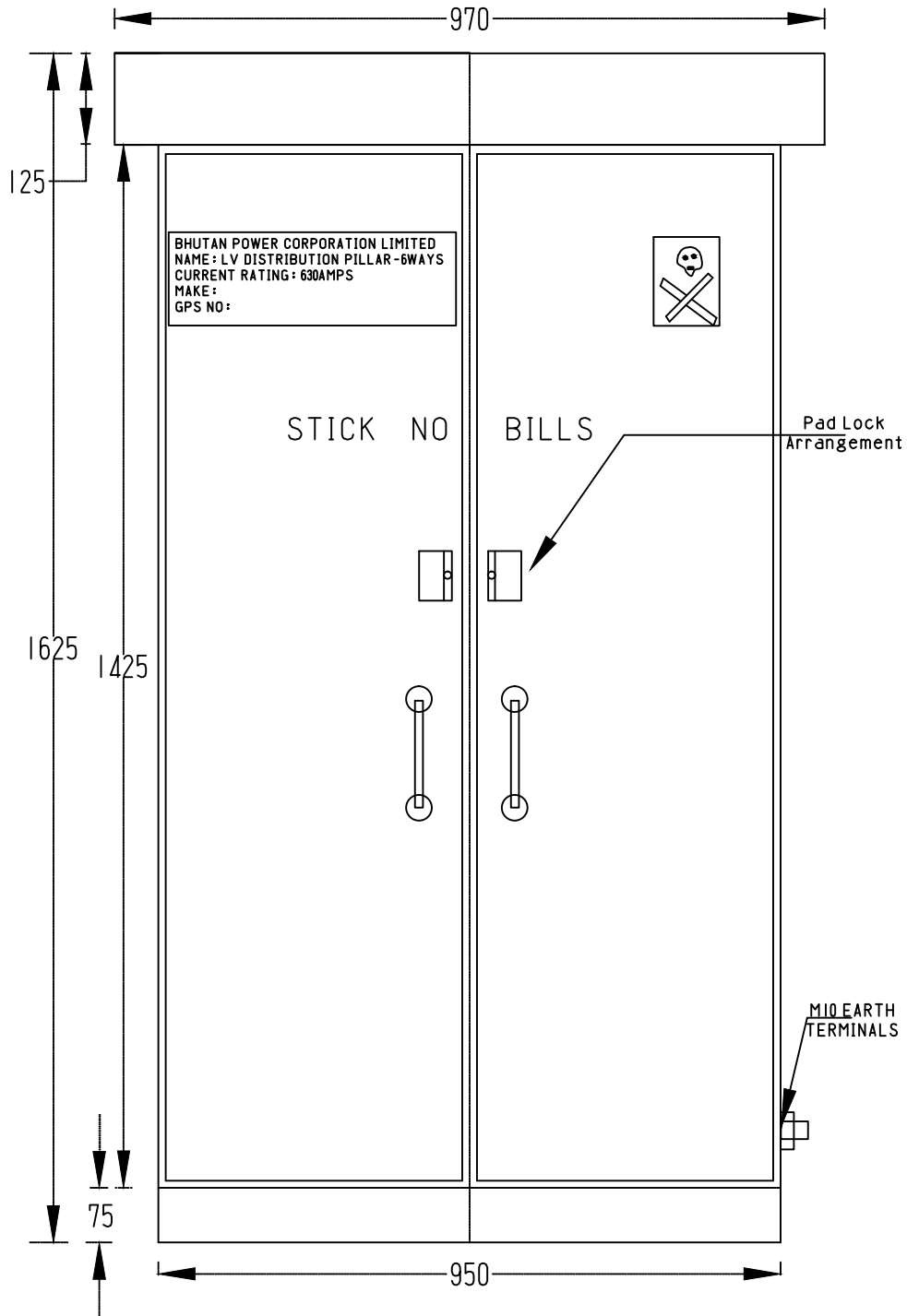

NOTES

1. DIMENSIONS AS SHOWN ARE IN MM.
2. DRAWING NOT TO SCALE.

	<p style="text-align: center;">BHUTAN POWER CORPORATION LIMITED</p>		ENGINEERING DESIGN & CONTRACTS DEPARTMENT	
			TITLE : DISTRIBUTION DESIGN & CONSTRUCTION STANDARD	
6WAYS TRANSFORMER DISTRIBUTION PILLAR (FRONT ELEVATION)			REVISION	
DESIGNATION	NAME	DATE	DRAWING NO. BPC-DDCS-2015-57/1	
DRAFTSMAN				
DESIGNER				
DESIGN CHECK				
PROJECT MANAGER				
PROJECT DIRECTOR			2015	

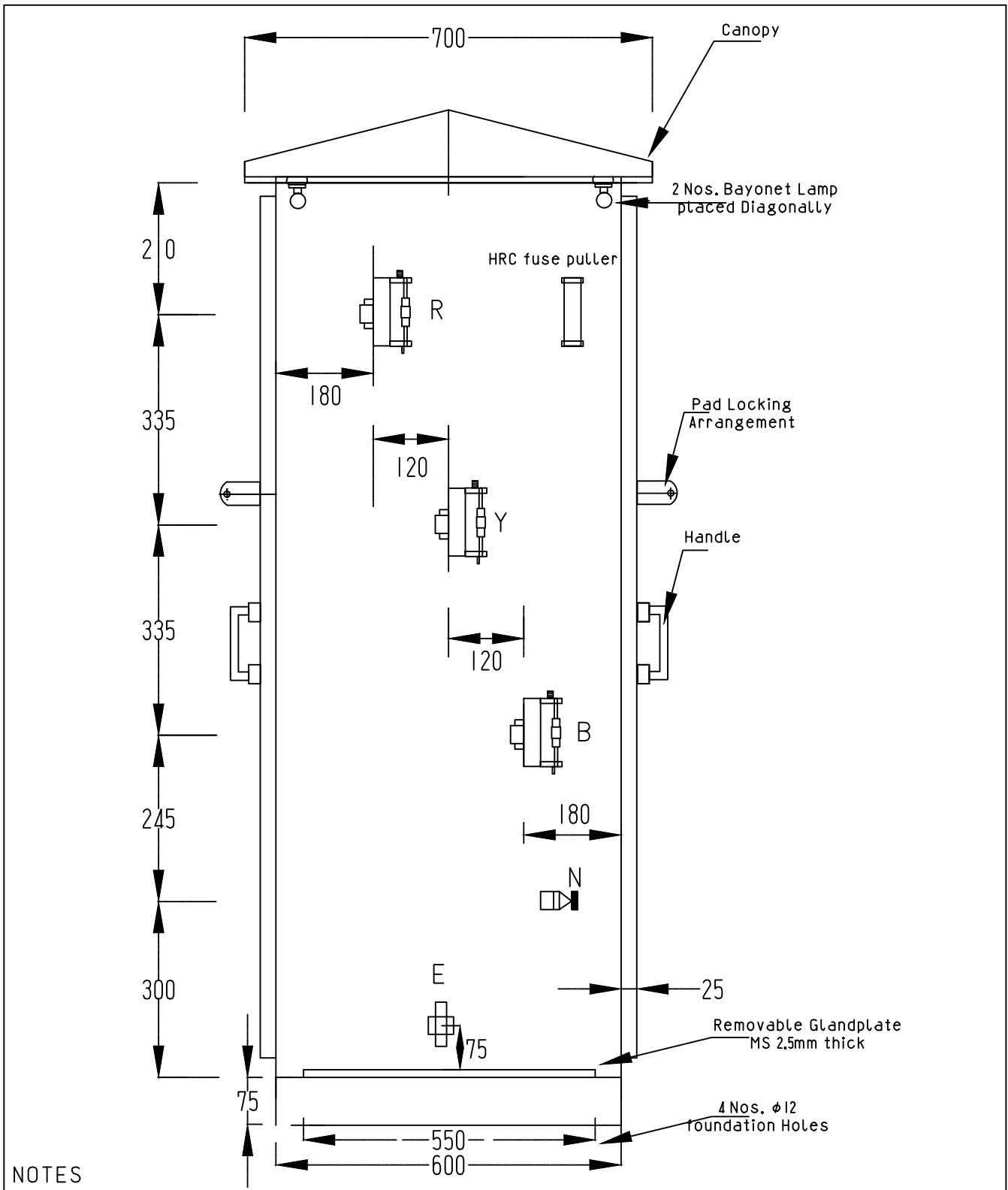

NOTES

1. DIMENSIONS AS SHOWN ARE IN MM.THE PILLAR SHALL BE TWO SIDED DOORS
2. DRAWING NOT TO SCALE.

 <p>BHUTAN POWER CORPORATION LIMITED</p>	ENGINEERING DESIGN & CONTRACTS DEPARTMENT	
	TITLE : DISTRIBUTION DESIGN & CONSTRUCTION STANDARD	
6WAYS TRANSFORMER DISTRIBUTION PILLAR (SIDE ELEVATION)		
DESIGNATION	NAME	DATE
DRAFTSMAN		
DESIGNER		
DESIGN CHECK		
PROJECT MANAGER		
PROJECT DIRECTOR		
DRAWING NO. BPC-DDCS-2015-57/2		REVISION
		2015

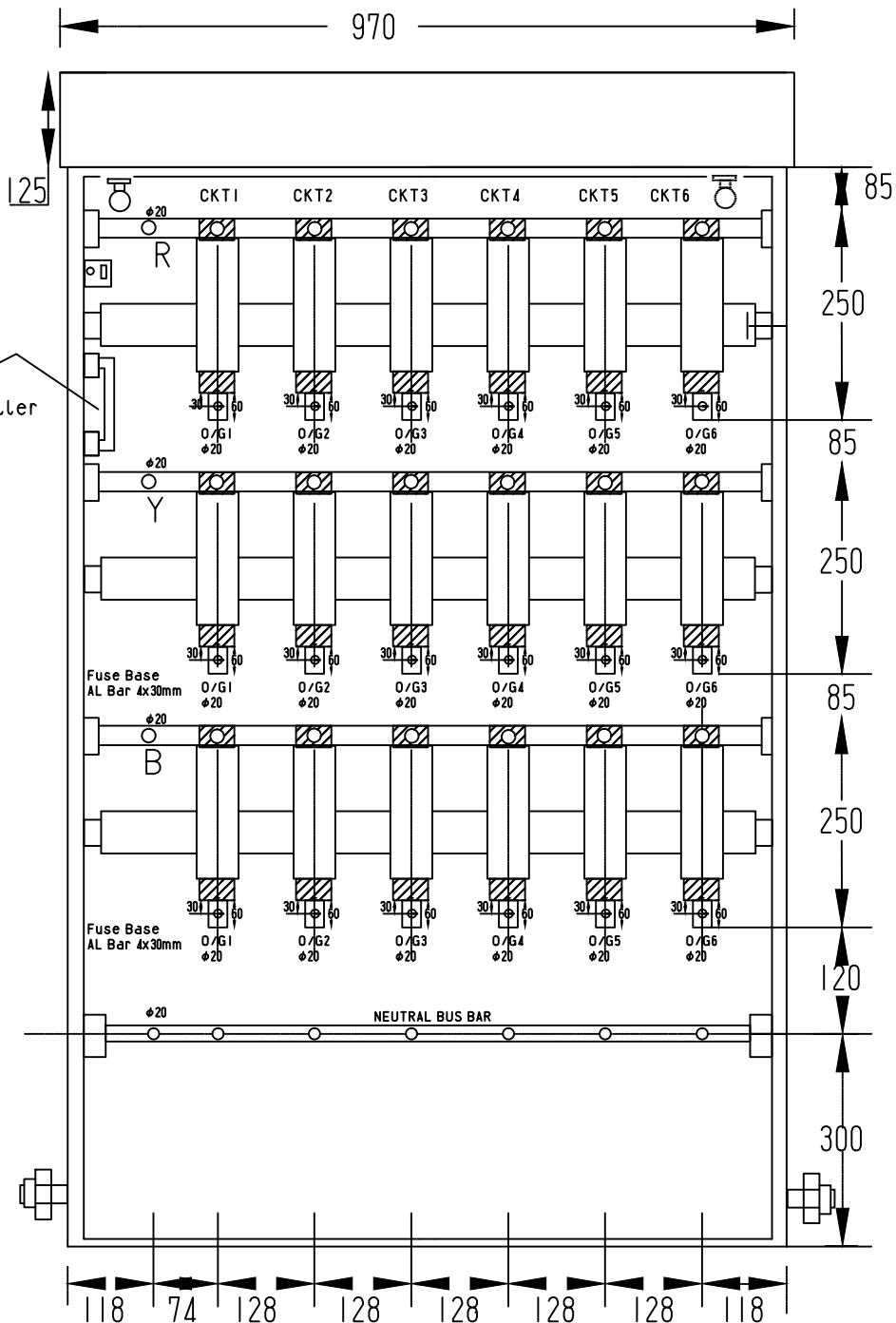

NOTES

1. DIMENSIONS AS SHOWN ARE IN MM.
2. PROVIDE ONE NO. FUSE FULLER FOR EVERY DISTRIBUTION BOARD
3. HRC FUSE RATING :
 400AMPS FOR 315KVA TRANSFORMER
 500AMPS FOR 400-500KVA TRANSFORMER



BHUTAN POWER CORPORATION LIMITED

ENGINEERING DESIGN & CONTRACTS DEPARTMENT

TITLE : DISTRIBUTION DESIGN & CONSTRUCTION STANDARD

**6WAYS TRANSFORMER DISTRIBUTION PILLAR
(FRONT ELEVATIONWITHOUT DOOR)**

DESIGNATION	NAME	DATE
DRAFTSMAN		
DESIGNER		
DESIGN CHECK		
PROJECT MANAGER		
PROJECT DIRECTOR		

DRAWING NO. BPC-DDCS-2015-57/3

REVISION
2015

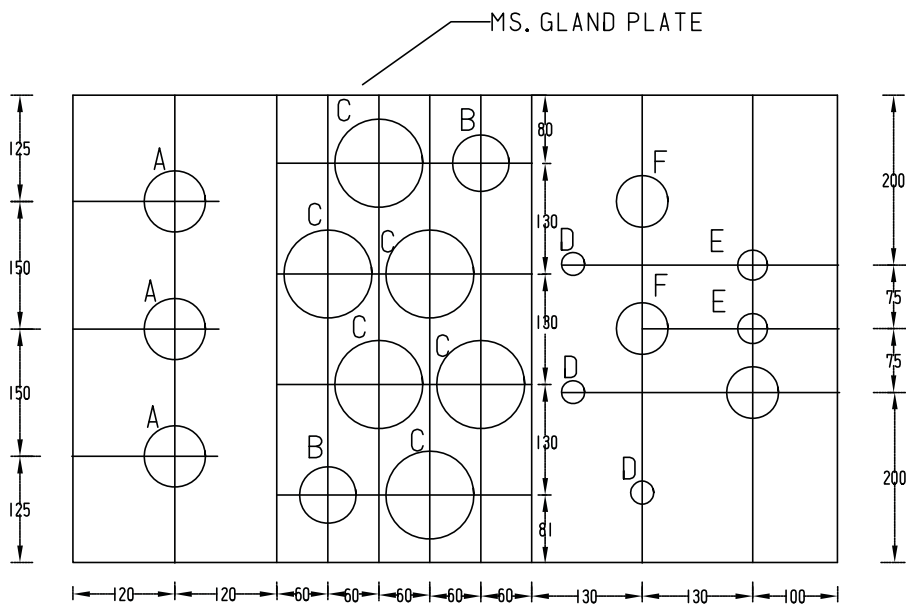

MS. GLAND PLATE	HOLE SIZE
A - 1CX400SQ.MM - KNOCKOUT	3"
B - 4CX300SQ.MM - KNOCKOUT	2-3/4"
C - 4CX400SQ.MM - KNOCKOUT	3-1/8"
D - 1CX300SQ.MM - KNOCKOUT	1-1/2"
E - 4CX150SQ.MM - KNOCKOUT	2"
F - 4CX240SQ.MM - KNOCKOUT	2-1/2"
G - 4CX95SQ.MM - KNOCKOUT	1-3/4"
h - 2CX6SQ.MM	3/4"
I - 2CX10SQ.MM	1"

NOTES

1. DIMENSIONS AS SHOWN ARE IN MM.
2. DRAWING NOT TO SCALE.
3. CORRECT CABLE GLAND SIZE TO BE USED ACCORDINGLY WITH CABLE SIZE

 <p style="text-align: center;">BHUTAN POWER CORPORATION LIMITED</p>	ENGINEERING DESIGN & CONTRACTS DEPARTMENT	
	TITLE : DISTRIBUTION DESIGN & CONSTRUCTION STANDARD	
6WAYS TRANSFORMER DISTRIBUTION PILLAR (GLAND PLATE DETAILS)		
DESIGNATION	NAME	DATE
DRAFTSMAN		
DESIGNER		
DESIGN CHECK		
PROJECT MANAGER		
PROJECT DIRECTOR		
DRAWING NO. BPC -DDCS -2015 -57/4		REVISION 2015

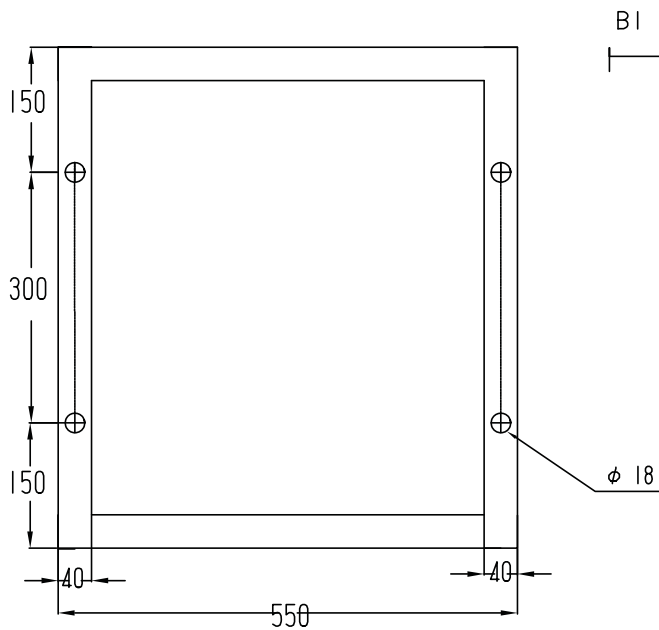

FOUNDATION PLAN

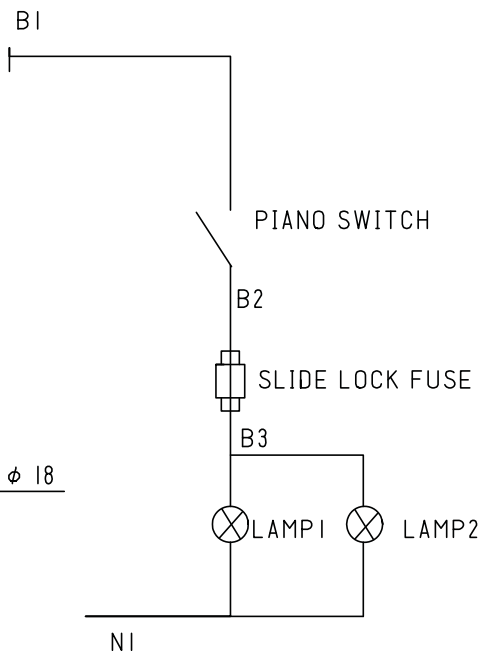

NOTES :
 PHASE -50X10MM AL -3NOS.
 NEUTRAL -50X10MM AL -1 NO. MATERIAL -THE FEEDER PILLAR (INCLUDING
 BASE CHANNEL) SHALL BE FABRICATED OUT OF 2,5MM MS SHEET,
 PAINT -SEIMENS GREY.
 EARTH -1X6X19MM, AL ALLOY.

NOTES

1. DIMENSIONS AS SHOWN ARE IN MM.
2. DRAWING NOT TO SCALE.

 BHUTAN POWER CORPORATION LIMITED			ENGINEERING DESIGN & CONTRACTS DEPARTMENT	
			TITLE : DISTRIBUTION DESIGN & CONSTRUCTION STANDARD	
			6WAYS TRANSFORMER DISTRIBUTION PILLAR (FOUNDATION DETAILS AND LIGHTING CKT)	
DESIGNATION	NAME	DATE	DRAWING NO. BPC -DDCS -2015 -57/5	
DRAFTSMAN				
DESIGNER				
DESIGN CHECK				
PROJECT MANAGER				
PROJECT DIRECTOR			REVISION 2015	

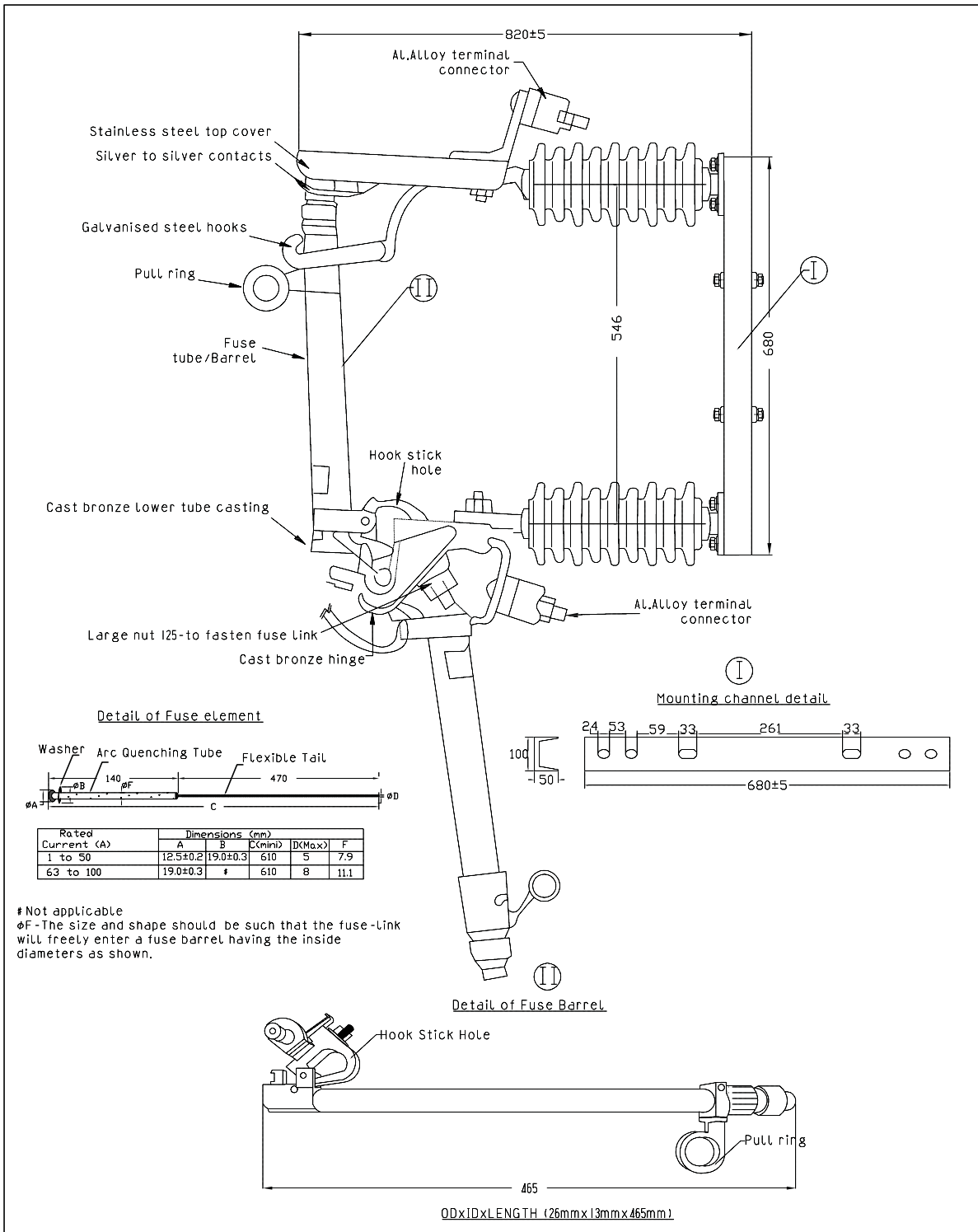

Detail of Fuse element

Washer Arc Quenching Tube Flexible Tail

140 470

Rated Current (A)	Dimensions (mm)				
	A	B	C(min)	D(Max)	F
1 to 50	12.5±0.2	19.0±0.3	610	5	7.9
63 to 100	19.0±0.3	#	610	8	11.1

Not applicable
 φF - The size and shape should be such that the fuse-link will freely enter a fuse barrel having the inside diameters as shown.

	BHUTAN POWER CORPORATION LIMITED	ENGINEERING DESIGN & CONTRACTS DEPARTMENT	
		TITLE : DISTRIBUTION DESIGN & CONSTRUCTION STANDARD	
DESIGNATION		NAME	DATE
DRAFTSMAN			
DESIGNER			
DESIGN CHECK			
PROJECT MANAGER			
PROJECT DIRECTOR			
DRAWING NO. BPC-DDCS-2015-58			REVISION 2015

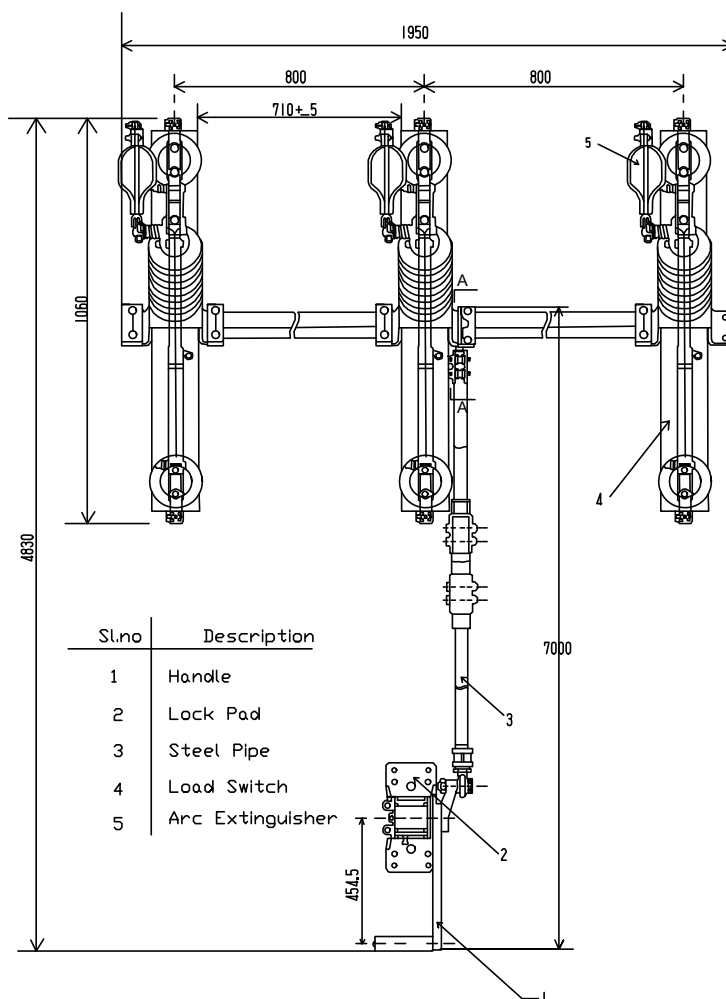
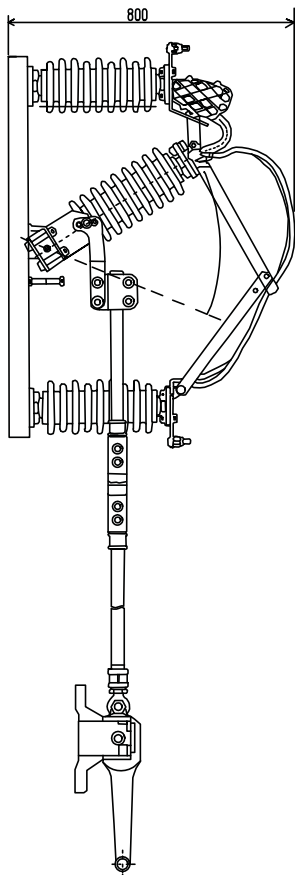

Sl.no	Description
1	Handle
2	Lock Pad
3	Steel Pipe
4	Load Switch
5	Arc Extinguisher

Rated Voltage:
 Rated short time Withstand current for 1 sec.
 Current Rating:
 Diameter and length of the GI operating Pipe
 Size & length of the channel for mounting
 Minimum clearances between phases
 Type of mounting
 Power frequency withstand Voltage
 1) Across Isolating Distance
 2) To earth and between poles
 Lightning impulse withstand Voltage
 1) Across Isolating Distance
 2) To earth and between poles
 Type of Insulator

11kV	33kV
20kA	16kA
630A	630A
25mm NBx6 mtr. Length	32mmx7 mtr. Length
75mmx40mmx660mm Long	75mmx40mmx660mm Long
800mm	800mm
vertical	vertical
32kV	80kV
28kV	70kV
85kV	195kV
75kV	170kV
Post Type with alternating shed	Post type with alternating shed



BHUTAN POWER CORPORATION LIMITED

ENGINEERING DESIGN & CONTRACTS DEPARTMENT

TITLE : DISTRIBUTION DESIGN & CONSTRUCTION STANDARD

Typical Arrangement of 11kV & 33 KV LBS/ABS

DESIGNATION	NAME	DATE
DRAFTSMAN		
DESIGNER		
DESIGN CHECK		
PROJECT MANAGER		
PROJECT DIRECTOR		

DRAWING NO. BPC-DDCS-2015-59

REVISION
2015

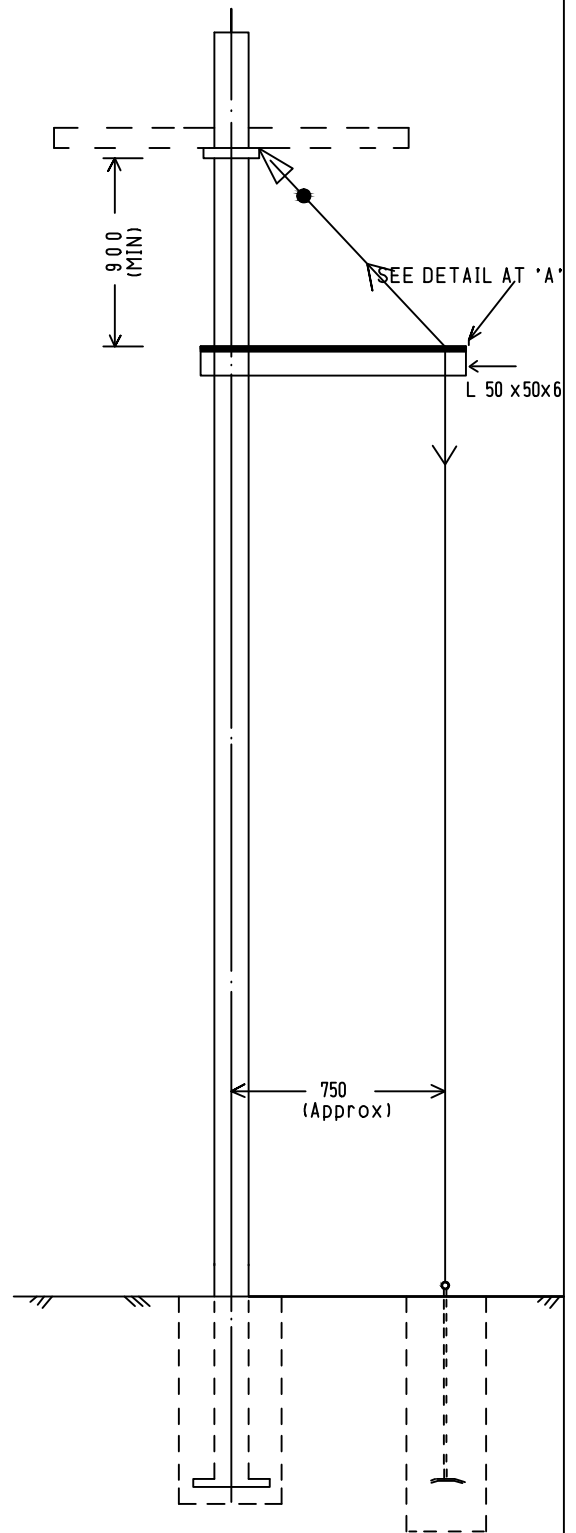
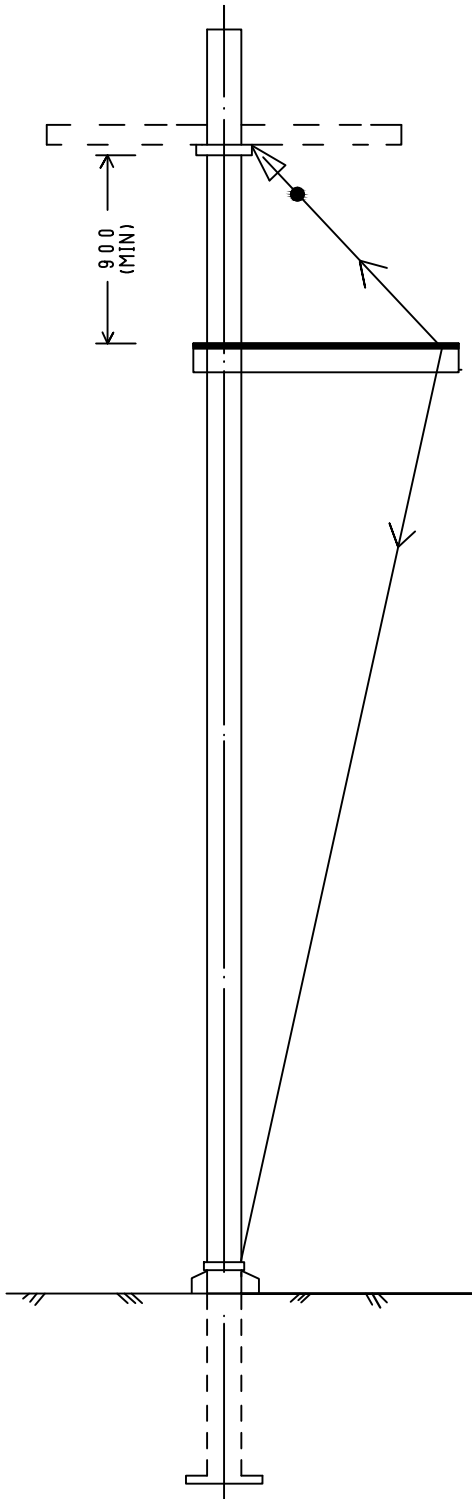

BHUTAN POWER CORPORATION LIMITED

ENGINEERING DESIGN & CONTRACTS DEPARTMENT

DISTRIBUTION DESIGN & CONSTRUCTION STANDARD

ARRANGEMENT OF BOW-GUY

DESIGNATION	NAME	DATE
DRAFTSMAN		
DESIGNER		
DESIGN CHECK		
PROJECT MANAGER		
PROJECT DIRECTOR		

DRAWING NO. BPC-DDCS-2015-60/1

REVISION
2015

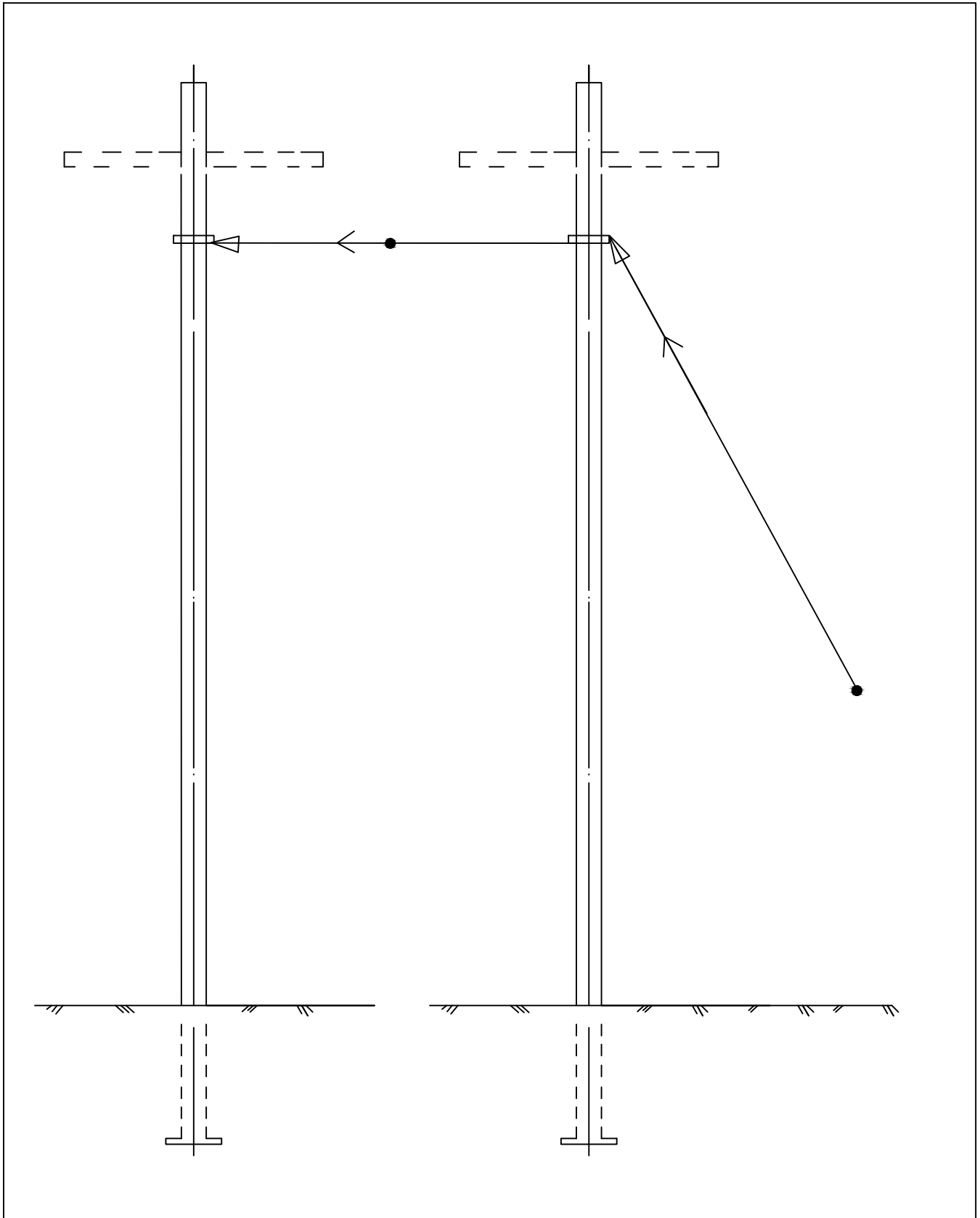

BHUTAN POWER CORPORATION LIMITED

ENGINEERING DESIGN & CONTRACTS DEPARTMENT

DISTRIBUTION DESIGN & CONSTRUCTION STANDARD

ARRANGEMENT OF FLY-GUY

DESIGNATION	NAME	DATE
DRAFTSMAN		
DESIGNER		
DESIGN CHECK		
PROJECT MANAGER		
PROJECT DIRECTOR		

DRAWING NO. BPC-DDCS-2015-60/2

REVISION
2015

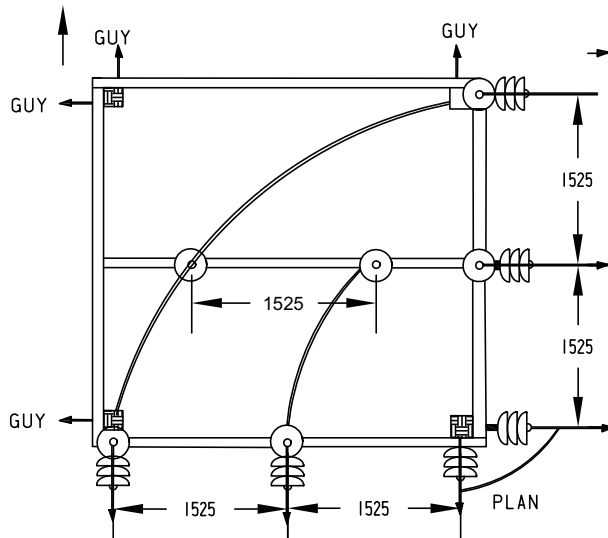
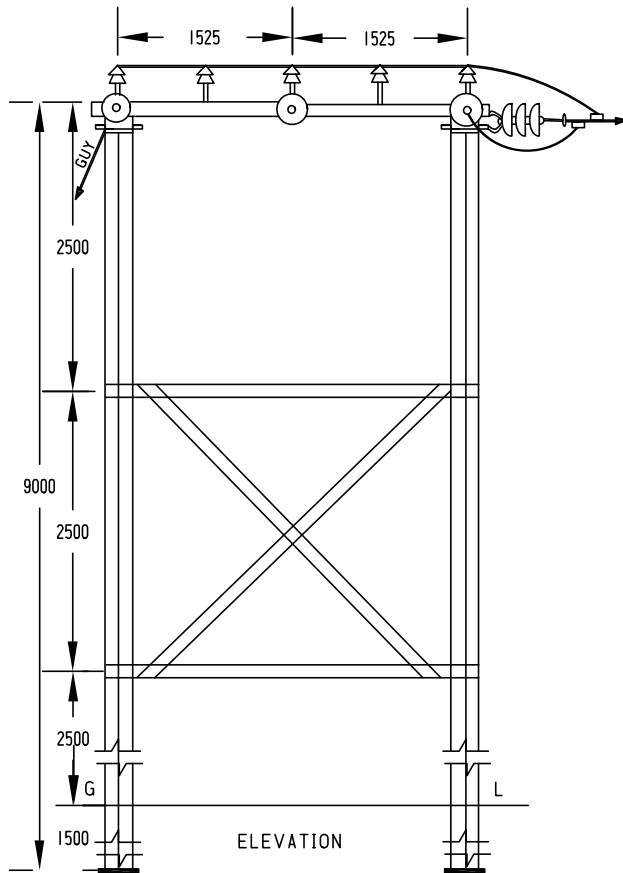

BILL OF MATERIAL

SUPPORT 9.0M	4 Nos.
33kV PIN INSULATORS	6 Nos.
33kV DISC INSULATORS	6 SETs
M.S CHANNEL 100X50X6-3150	5 Nos.
∠65X65X6 BELT	8 Nos.
∠50X50X6 BRACING	8 Nos.
EARTHING MATERIAL	AS REQD.
NUTS, BOLTS, POLE CLAMPS ETC	AS REQD.
BASE PLATE	4 Nos.
GUY SET	4 Nos.

ALL DIMENSION ARE IN mm

 <p>BHUTAN POWER CORPORATION LIMITED</p>	ENGINEERING DESIGN & CONTRACTS DEPARTMENT	
	TITLE : DISTRIBUTION DESIGN & CONSTRUCTION STANDARD	
DESIGNATION	NAME	DATE
DRAFTSMAN		
DESIGNER		
DESIGN CHECK		
PROJECT MANAGER		
PROJECT DIRECTOR		
ARRANGEMENT OF CONDUCTORS AT ANGLE LOCATIONS - FOUR POLE STRUCTURE (60° TO 90° DEVIATION)		DRAWING NO. BPC-DDCS-2015-61
		REVISION 2015

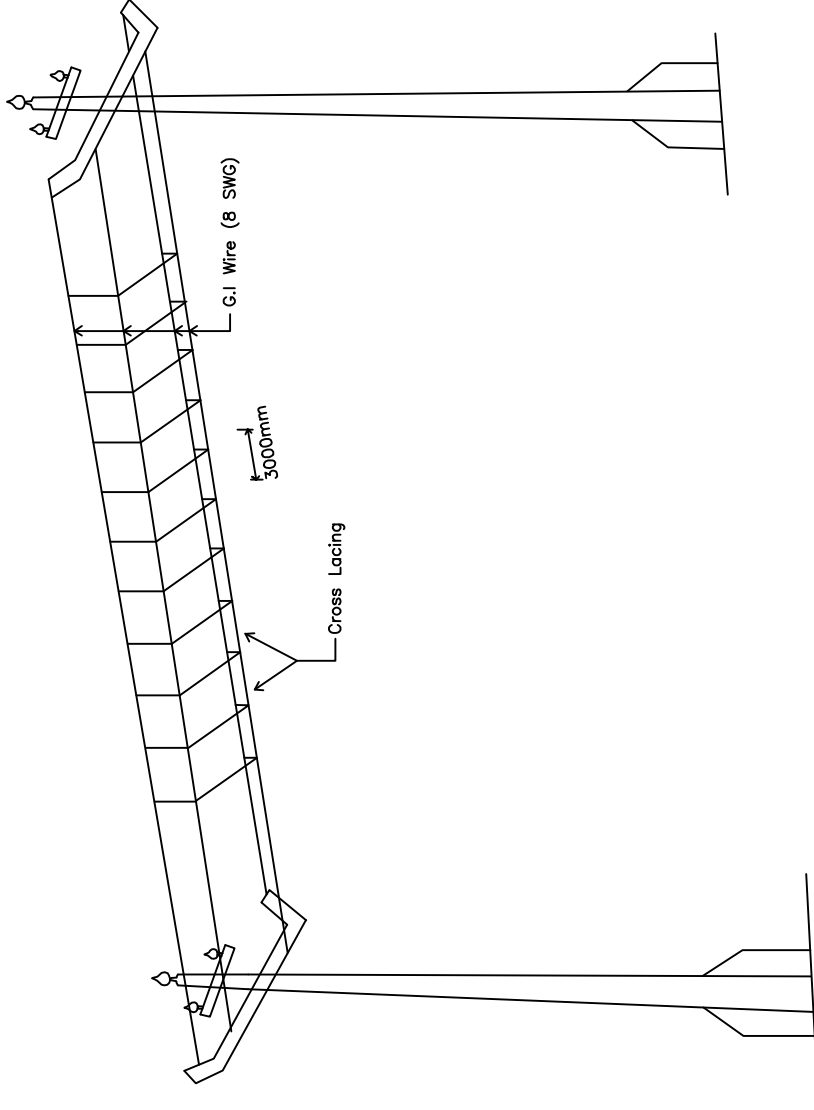

Cradle Type Guarding

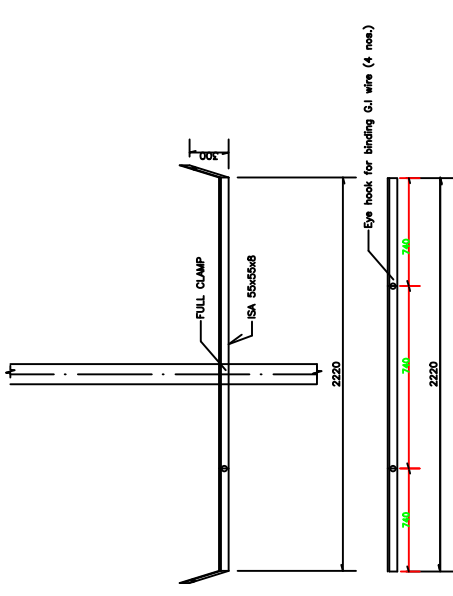

SINGLE POLE GUARD ARM

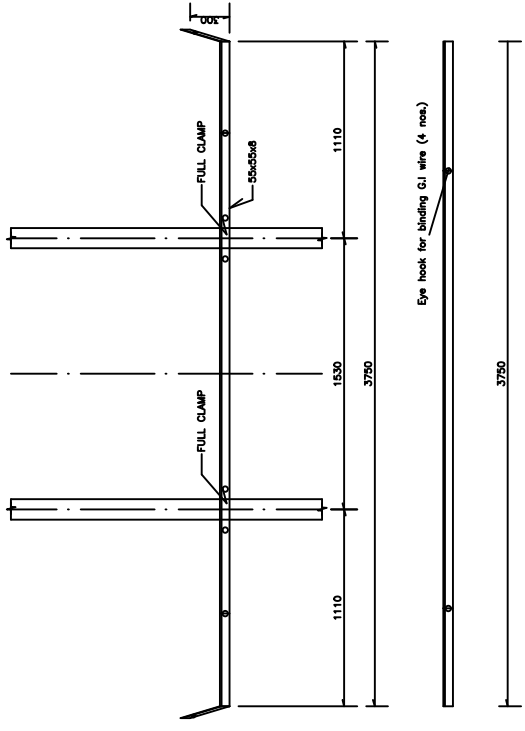

DOUBLE POLE GUARD ARM FOR IS POLE



BHUTAN POWER CORPORATION LIMITED

ENGINEERING & DESIGN AND CONTRACTS DEPARTMENT

TITLE	NAME	DATE
DESIGNED BY		
CHECKED BY		
APPROVED BY		

DISTRIBUTION DESIGN & CONSTRUCTION STANDARD

INDICATIVE DRAWING OF GUARDING FOR 11 & 33 KV SYSTEM FOR IS POLE

DRAWING NO. BPC - DDCS - 2015 - 62

REVISION 2015

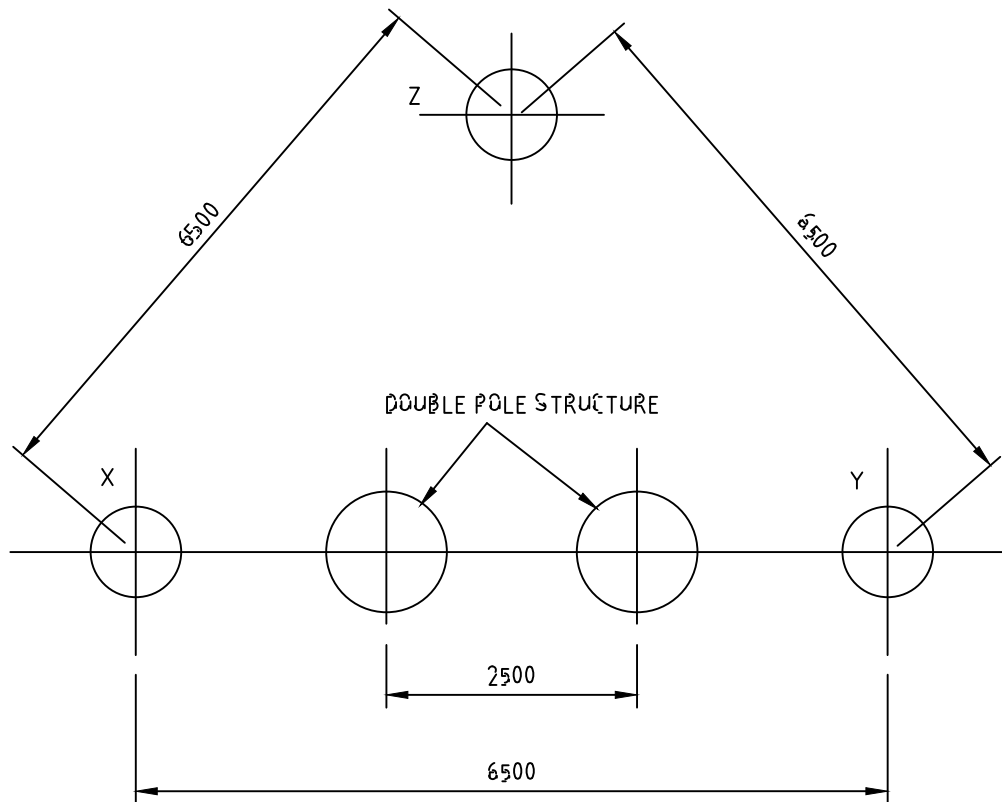

NOTES

1. THE CONNECTIONS TO THE THREE EARTH ELECTRODES SHOULD BE AS FOLLOWS:
 - a. TO ONE OF THE EARTH ELECTRODES ON EITHER SIDE OF DOUBLE POLE STRUCTURE (X-Y)
ONE DIRECT CONNECTION FROM 33kV OR 11kV NEUTRAL LIGHTNING ARRESTERS AND TRANSFORMER TANK
 - b. TO EACH OF THE REMAINING TWO EARTH-ELECTRODES
 - (i) ONE SEPARATE CONNECTION FROM THE NEUTRAL OF THE LOW VOLTAGE SIDE OF THE TRANSFORMER.
 - (ii) ONE SEPARATE CONNECTION FROM TERMINAL EARTH OF TRANSFORMER LT PANEL .
 - (iii) ONE SEPARATE CONNECTION FROM BODY OF TRANSFORMER LT PANEL .
2. 25 x 6 mm GALVANISED IRON STRAP LEADS.
3. THREE NOS. 40mm x 2500mm PIPE ELECTODES.
4. EARTH ELECTRODES X,Y AND Z TO BE BONDED TOGETHER USING 25x6mm GALVANISED IRON STRAP BURIED 100mm BELOW GROUND LEVEL.
5. REFER DWG BPC-DDCS-2015-66 FOR EARTH POINTS ON TRANSFORMER AND STRUCTURE.



BHUTAN POWER
CORPORATION LIMITED

ENGINEERING DESIGN & CONTRACTS DEPARTMENT

TITLE : DISTRIBUTION DESIGN & CONSTRUCTION STANDARD

33 kV OR 11 kV / 415 V DISTRIBUTION SUB-STATION
PIPE EARTHING

DESIGNATION	NAME	DATE
DRAFTSMAN		
DESIGNER		
DESIGN CHECK		
PROJECT MANAGER		
PROJECT DIRECTOR		

DRAWING NO. BPC-DDCS-2015-64

REVISION
2015

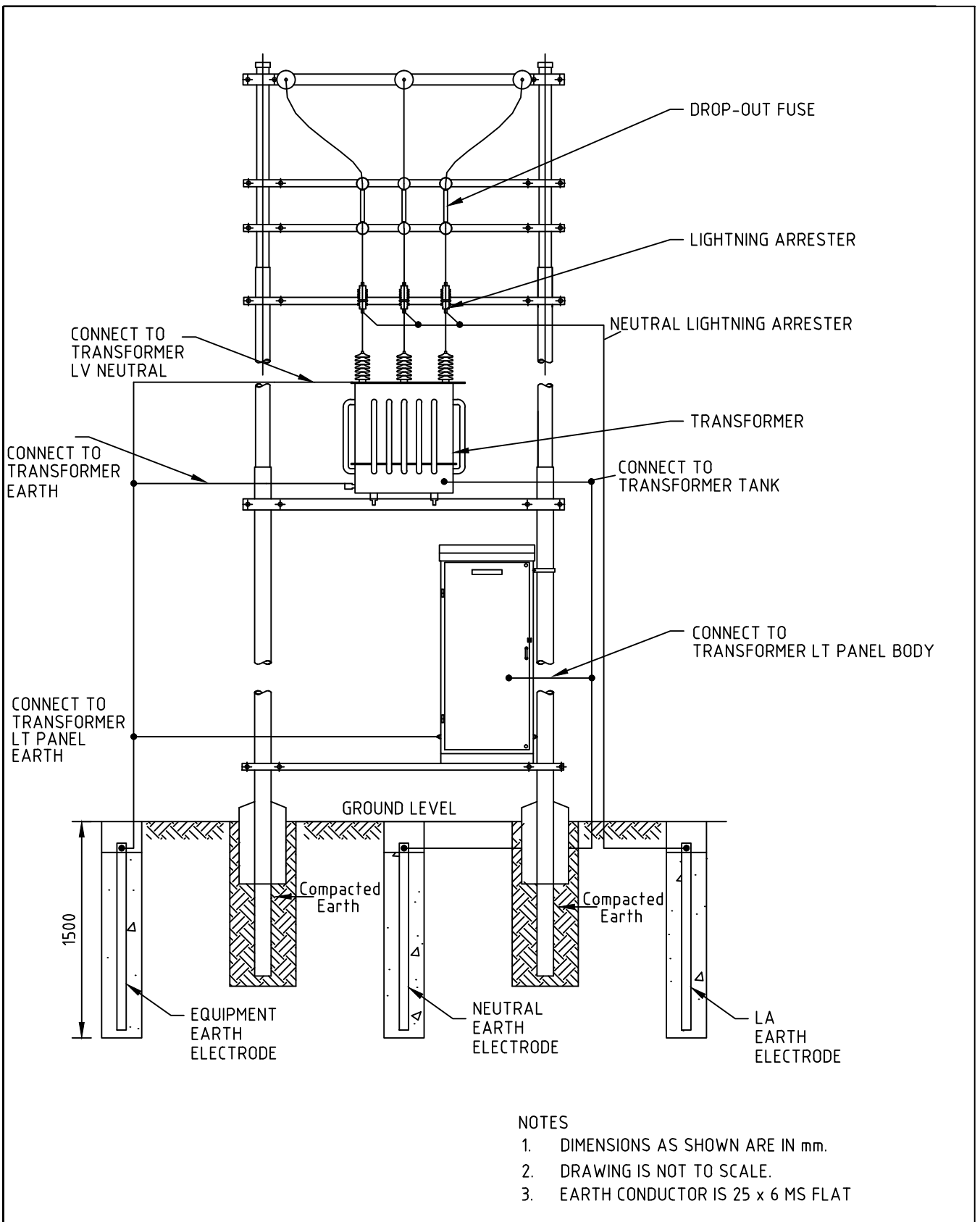

- NOTES
1. DIMENSIONS AS SHOWN ARE IN mm.
 2. DRAWING IS NOT TO SCALE.
 3. EARTH CONDUCTOR IS 25 x 6 MS FLAT



BHUTAN POWER CORPORATION LIMITED

ENGINEERING DESIGN & CONTRACTS DEPARTMENT

TITLE : DISTRIBUTION DESIGN & CONSTRUCTION STANDARD

DISTRIBUTION SUBSTATION TYPICAL EARTHING SCHEME ARRANGEMENT

DESIGNATION	NAME	DATE
DRAFTSMAN		
DESIGNER		
DESIGN CHECK		
PROJECT MANAGER		
PROJECT DIRECTOR		

DRAWING NO. BPC-DDCS-2015-65

REVISION
2015

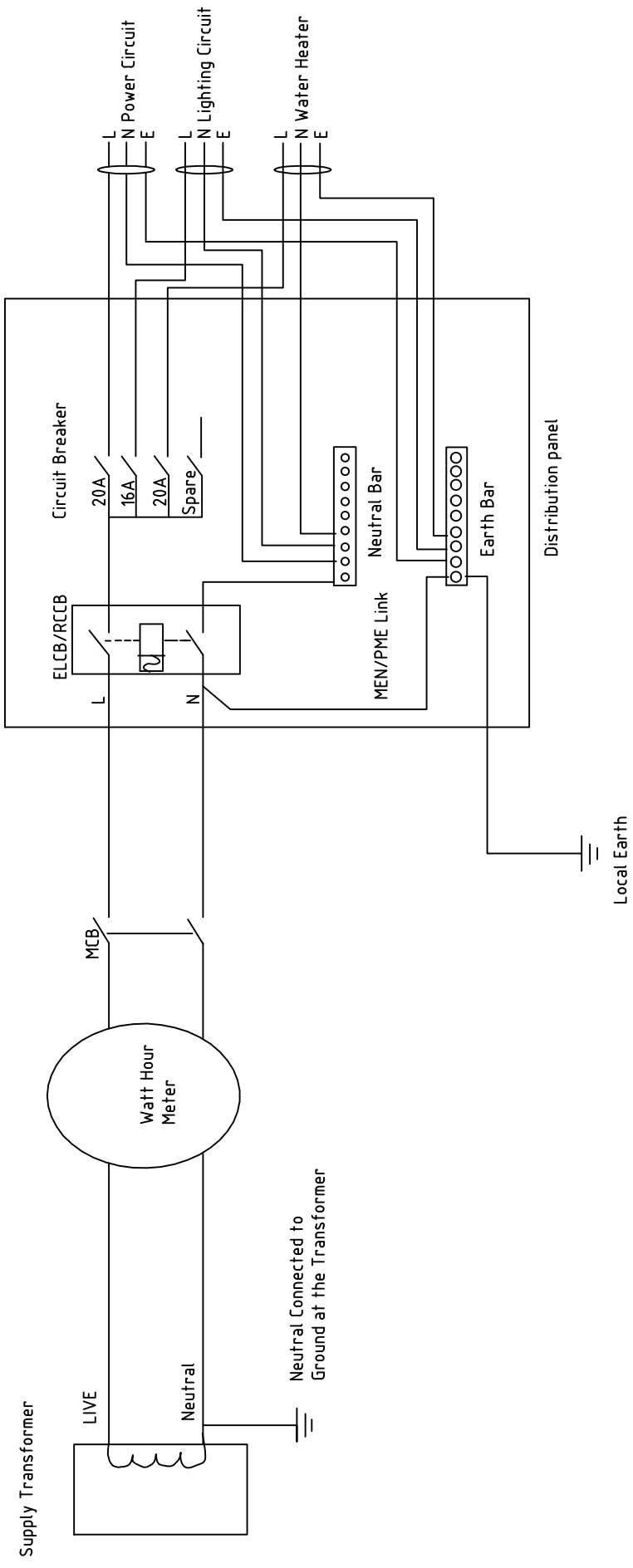

Alternative neutral earth connection where RCCB is used.



BHUTAN POWER CORPORATION LIMITED

ENGINEERING & DESIGN AND CONTRACTS DEPARTMENT

DISTRIBUTION DESIGN & CONSTRUCTION STANDARD
CONSUMER CONNECTION ARRANGEMENT

TITLE	NAME	DATE
DESIGNED BY		
CHECKED BY		
APPROVED BY		

DRAWING NO. BPC - DDCS - 2015 - 66

REVISION 2015

INSTALLATION OF DIRECTLY BURIED CABLES

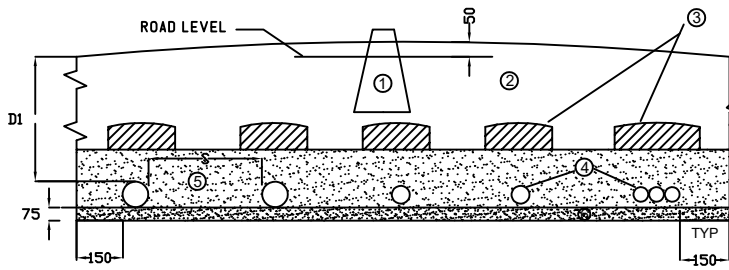

DIRECTLY BURIED CABLES IN SINGLE LAYER

LEGEND

- (1) - CABLE ROUTE MARKER IF PROVIDED..
- (2) - EARTH BACK FILLED & RAMMED.
- (3) - PROTECTIVE COVERS, AS PER IS 1255
- RCC/SLABS/BRICKS FOR HIGH VOLTAGE CABLES
- (4) - ARMoured POWER CABLE
- (5) - FINE SAND/ RIDDLED SOIL COMPACTED.
- (6) - SAND BEDDING

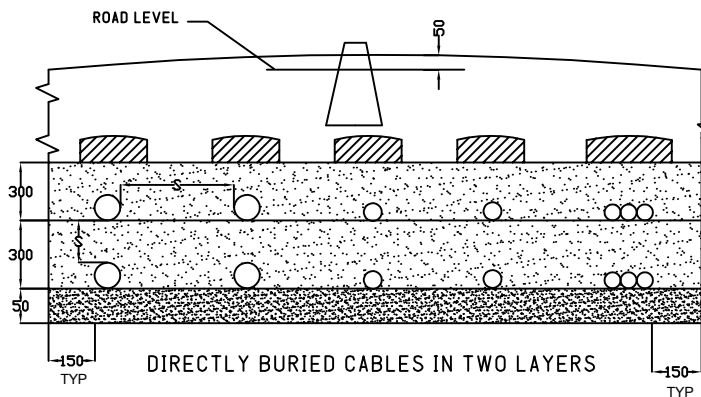

DIRECTLY BURIED CABLES IN TWO LAYERS

DIMENSION (MIN)	1100V GRADE CABLES	11kV	33kV
DI	600	1000	1000
S	d - BETWEEN CABLES OF SAME CLASS * 300mm - BETWEEN CABLES OF DIFFERENT CLASS * 400mm - BETWEEN I-CORE POWER CABLE AND COMMUNICATION CABLE * 400mm - BETWEEN MULTICORE POWER CABLE AND COMMUNICATION CABLE		

- d. - OVER ALL DIAMETER OF THE BIGGER OF THE TWO CABLE
- * - SPACING SHALL BE KEPT BOTH HORIZONTALLY AND VERTICALLY

NOTE

1. SINGLE CORE CABLES SHALL BE RUN IN TREFOIL FORMATION AND SHALL BE BOUND BY PLASTIC TAPES OR 3 mm DIA NYLON CORE EVERY 750mm
2. PLASTIC MARKING TAPE TO BE USED FOR UG WHICH SHALL RUN ALONG THE LENGTH OF THE CABLE AND SHALL HAVE CABLE MARKING AT EVERY 1.5METER LENGTH
3. CABLE IDENTIFICATION TAG SHALL BE TIED AT BOTH ENDS OF THE CABLE AND ALSO AT AN INTERVAL OF 15 METRES.
4. IF THE MINIMUM CLEARANCE AS INDICATED IN THE ABOVE TABLE FOR CABLES OF DIFFERENT CLASSES ARE NOT FEASIBLE, BRICK BARRIERS SHALL BE USED BETWEEN ADJACENT CABLES.
5. GI./HUME PIPE SHALL BE PROVIDED FOR ROAD CROSSING.

	BHUTAN POWER CORPORATION LIMITED		ENGINEERING AND RESEARCH DEPARTMENT	
			TITLE : DISTRIBUTION DESIGN & CONSTRUCTION STANDARD	
DESIGNED BY		INSTALLATION PRACTICE - DIRECTLY BURRIED CABLES		DRAWING NO. BPC-DDCS-2020-IA REVISION 2020
CHECKED BY				
APPROVED BY				

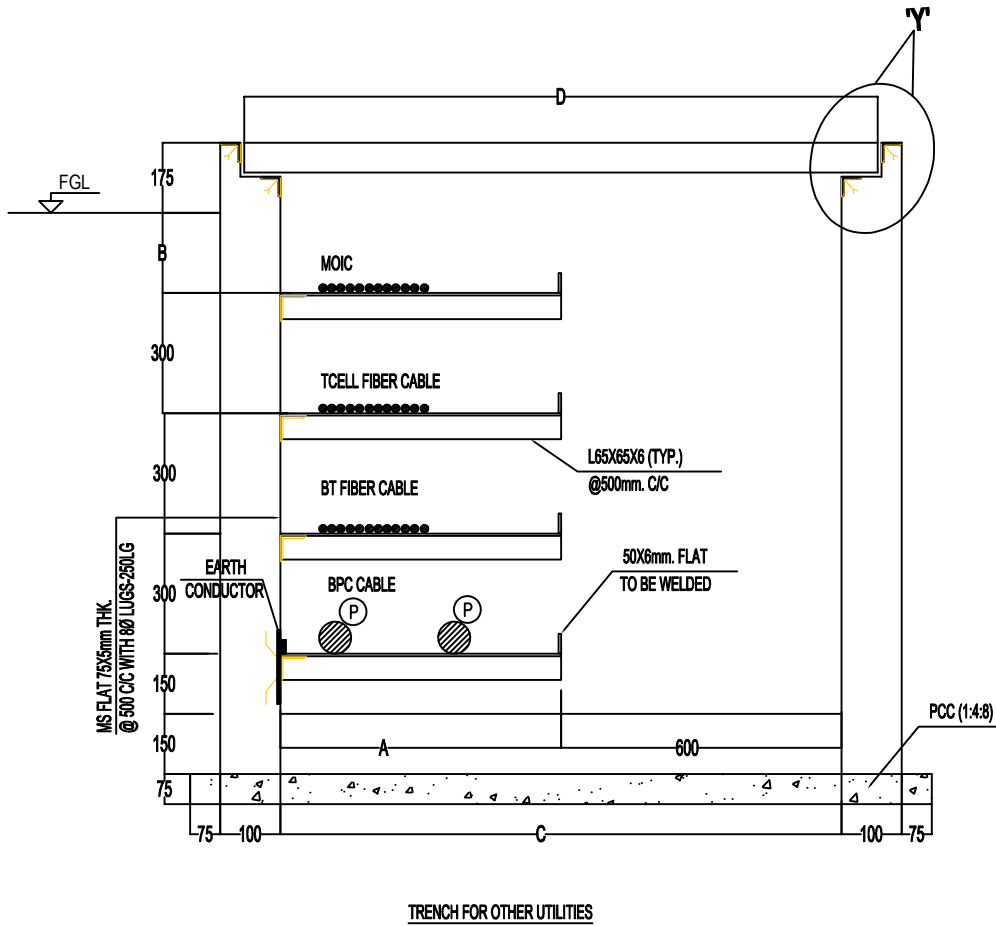
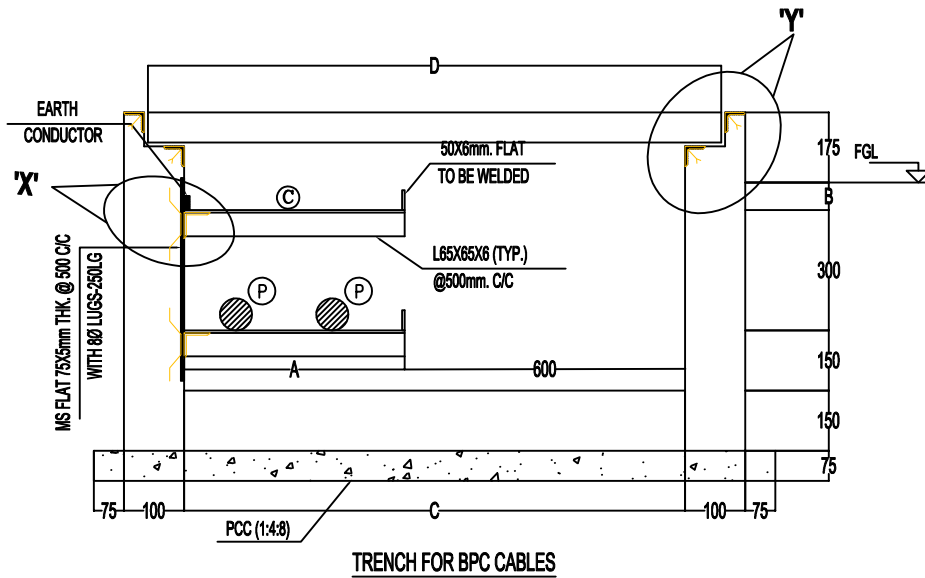

BHUTAN POWER CORPORATION LIMITED

ENGINEERING AND RESEARCH DEPARTMENT

TITLE : DISTRIBUTION DESIGN & CONSTRUCTION STANDARD

INSTALLATION PRACTICE -INTERNAL BPC & MULTI- UTILITY

	NAME	DATE
DESIGNED BY		
CHECKED BY		
APPROVED BY		

DRAWING NO. BPC-DDCS-2020-IB & C

REVISION
2020

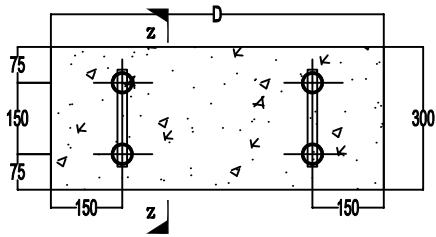

RCC cover slab plan

12Ø LIFTING HOOK

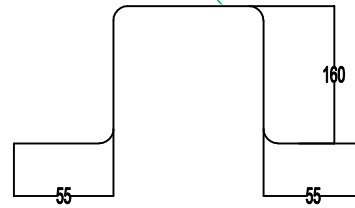

DET. OF LIFTING HOOK

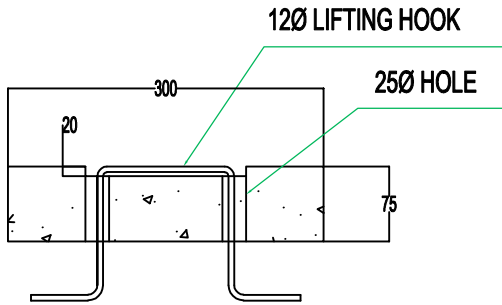

SECTION Z-Z COVER SLAB

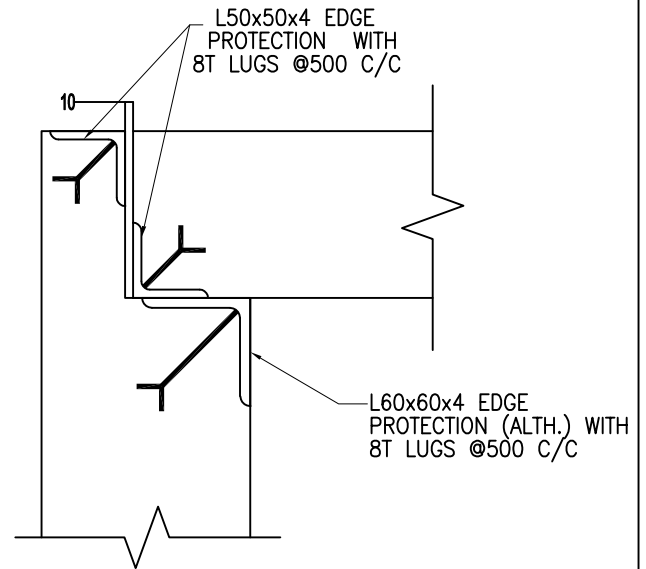

DETAIL Y-Y
TYPICAL DETAIL OF
CABLE TRENCH EDGE
PROTECTION

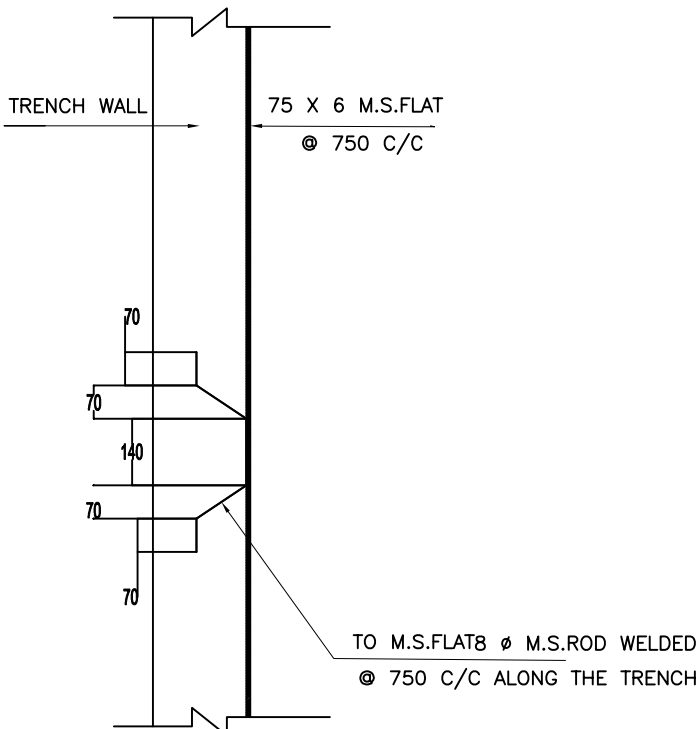

DETAIL X-X : ANCHORING
75X6 M.S. FLAT

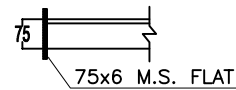

SECTION D-D

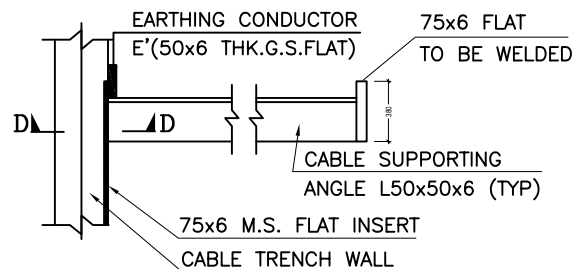

TYP. CABLE SUPPORT EARTH CONDUCTOR
E' RUNS ON TOP TIER ONLY



BHUTAN POWER CORPORATION
LIMITED

ENGINEERING AND RESEARCH DEPARTMENT

TITLE : DISTRIBUTION DESIGN & CONSTRUCTION STANDARD

INSTALLATION PRACTICE -DETAILS OF SLABS, LIFTING HOOKS & EDGE

DESIGNED BY

NAME

DATE

CHECKED BY

APPROVED BY

DRAWING NO. BPC-DDCS-2020-IB & C

REVISION
2020

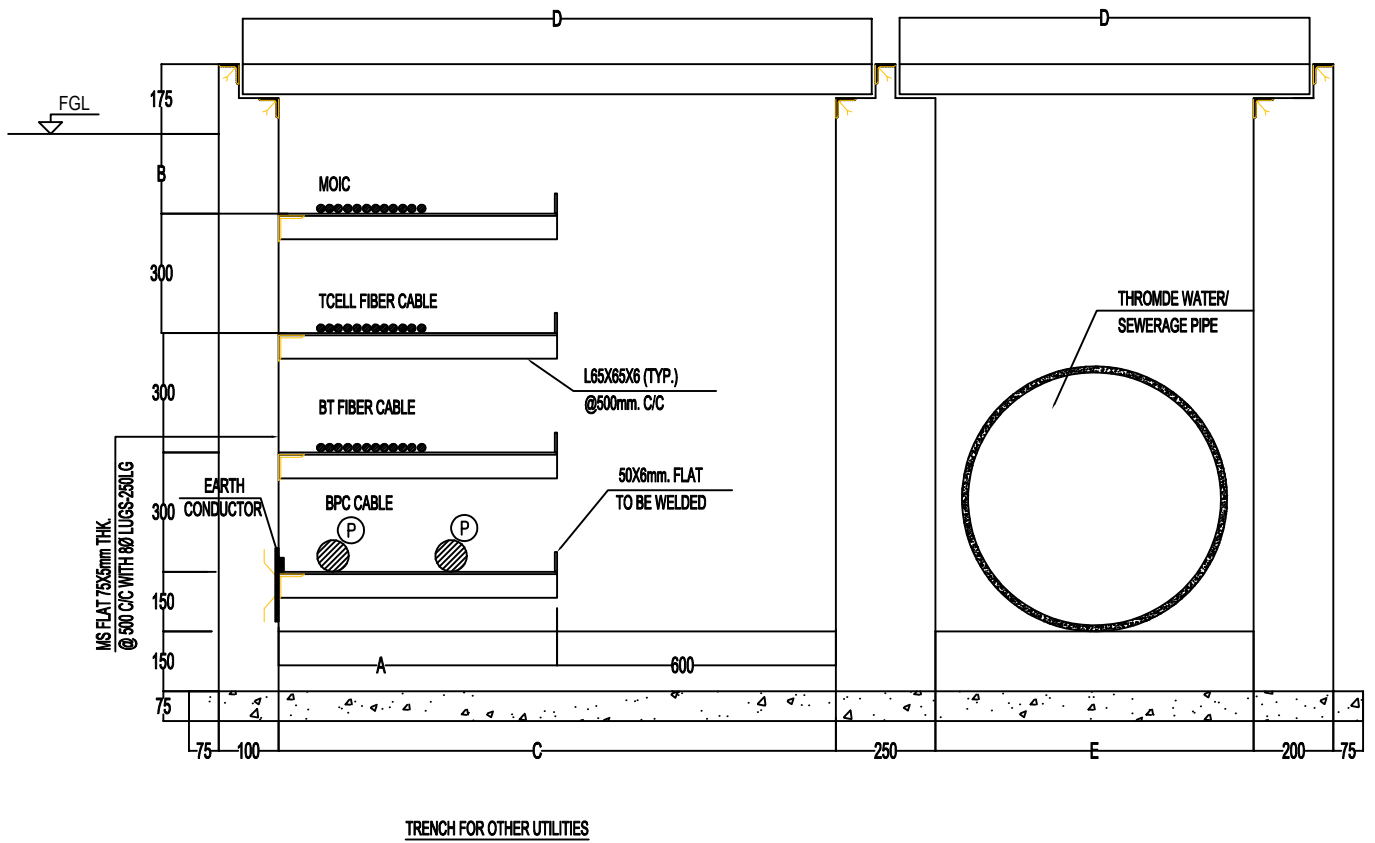

BHUTAN POWER CORPORATION LIMITED

ENGINEERING AND RESEARCH DEPARTMENT

TITLE : DISTRIBUTION DESIGN & CONSTRUCTION STANDARD

INSTALLATION PRACTICE -INTERNAL BPC & MULTI- UTILITY

	NAME	DATE
DESIGNED BY		
CHECKED BY		
APPROVED BY		

DRAWING NO. BPC-DDCS-2020-IC

REVISION
2020

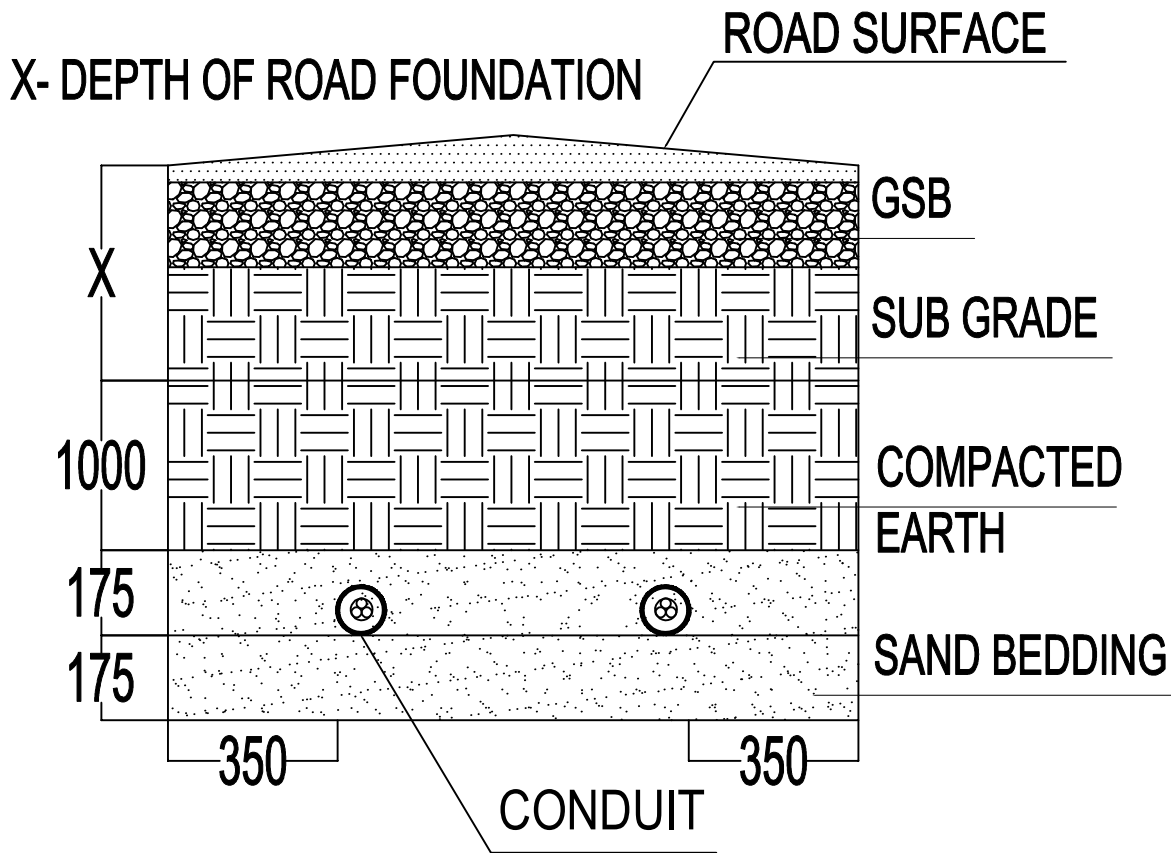

DIRECTLY BURIED CABLES WITH CONDUIT



BHUTAN POWER CORPORATION LIMITED

ENGINEERING AND RESEARCH DEPARTMENT

TITLE : DISTRIBUTION DESIGN & CONSTRUCTION STANDARD

INSTALLATION PRACTICE - CONDUIT METHOD

	NAME	DATE
DESIGNED BY		
CHECKED BY		
APPROVED BY		

DRAWING NO. BPC-DDCS-2020-ID

REVISION
2020

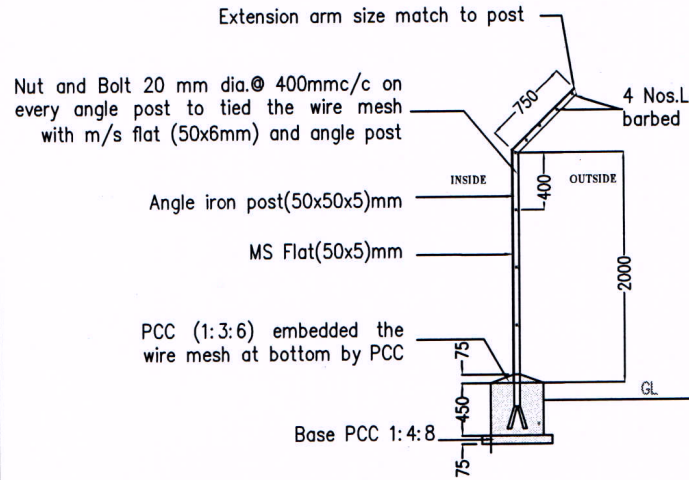

TYPICAL SECTION

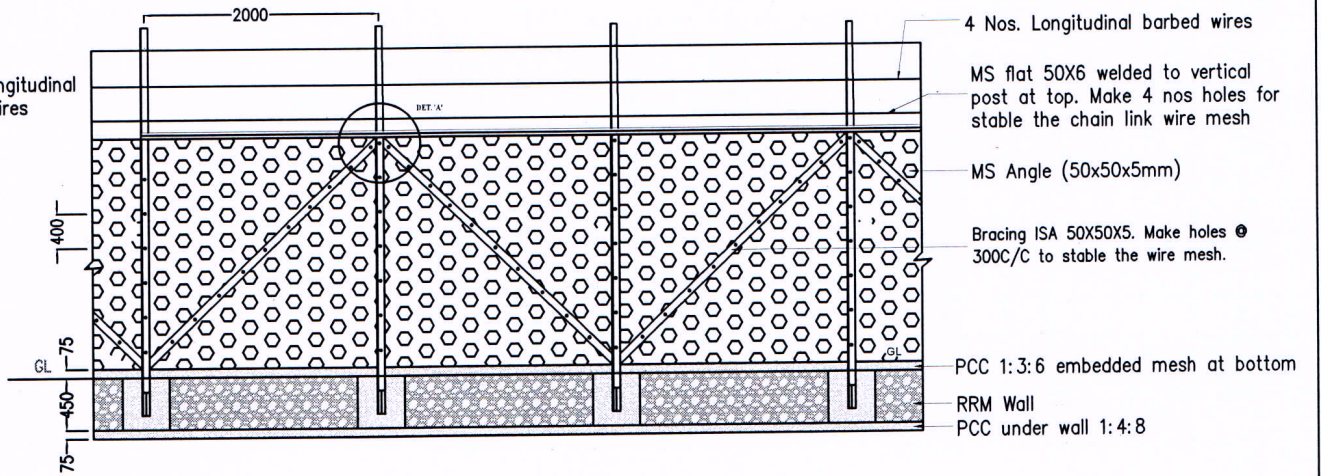

TYPICAL EXTERNAL ELEVATION

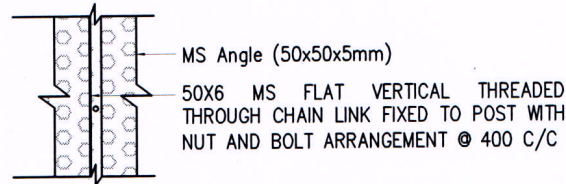

FIXING OF CHAIN LINK FABRIC OVER POST

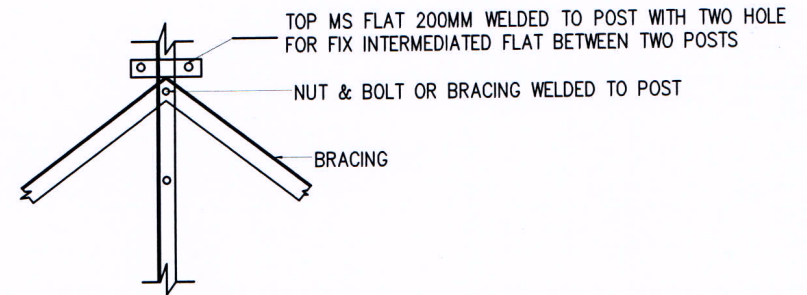

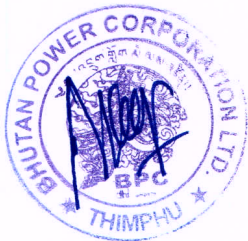

DETAIL - A

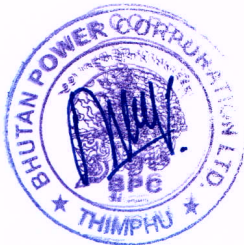
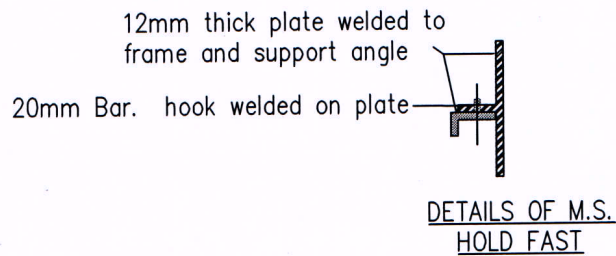
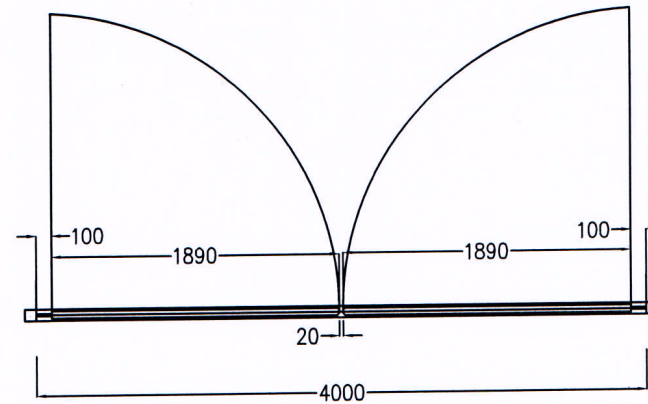
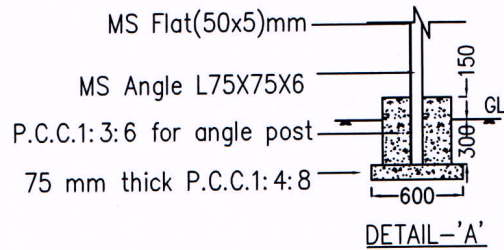
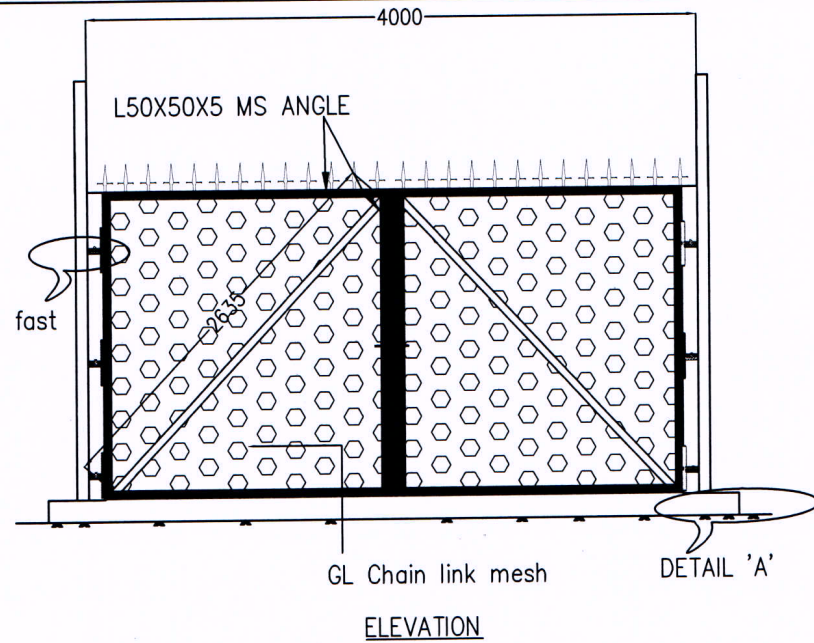
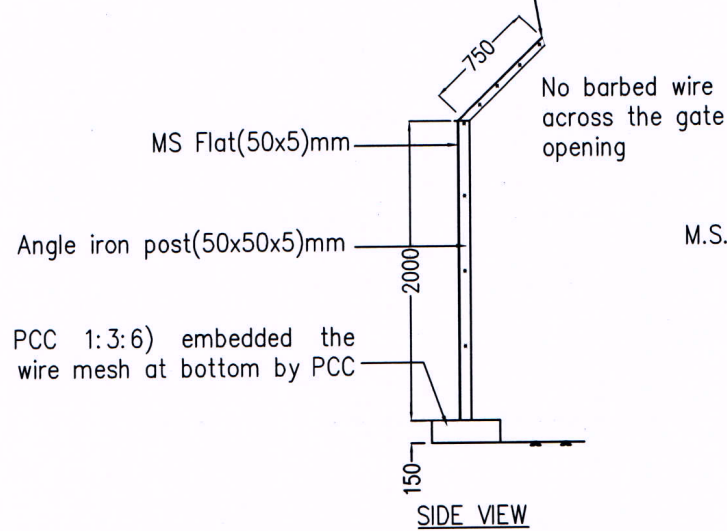

	DEPARTMENT : CONSTRUCTION & PROCUREMENT DEPARTMENT, BPC		
	DRAWING TITLE : CONSTRUCTION OF CHAIN LINK FENCING AND ITS GATE		
DIMENSION : MM	SIZE : A4	DRAWING NUMBER:	REV : 00
SCALE : 1:1	DRAWN BY: <i>[Signature]</i>	APPROVED BY: <i>[Signature]</i>	DATE: JULY, 2023

Extension arm size match to post



	DEPARTMENT : CONSTRUCTION & PROCUREMENT DEPARTMENT, BPC		
	DRAWING TITLE : CONSTRUCTION OF CHAIN LINK FENCING AND ITS GATE		
DIMENSION : MM	SIZE : A4	DRAWING NUMBER:	REV : 00
SCALE : 1:1	DRAWN BY : <i>[Signature]</i>	APPROVED BY : <i>[Signature]</i>	DATE: JULY, 2023

This drawing and design is the property of BPC and must not be passed on to any person who is not authorized by organization nor can be copied or lent without prior permission in writing from the concerned authority.

M/s Flat (50x6mm) fix to
with angle post to hold wire
mesh

MS Angle
L75X75X6

P.C.C.1:3:6 for
angle post

75 mm thick
P.C.C.1:4:8

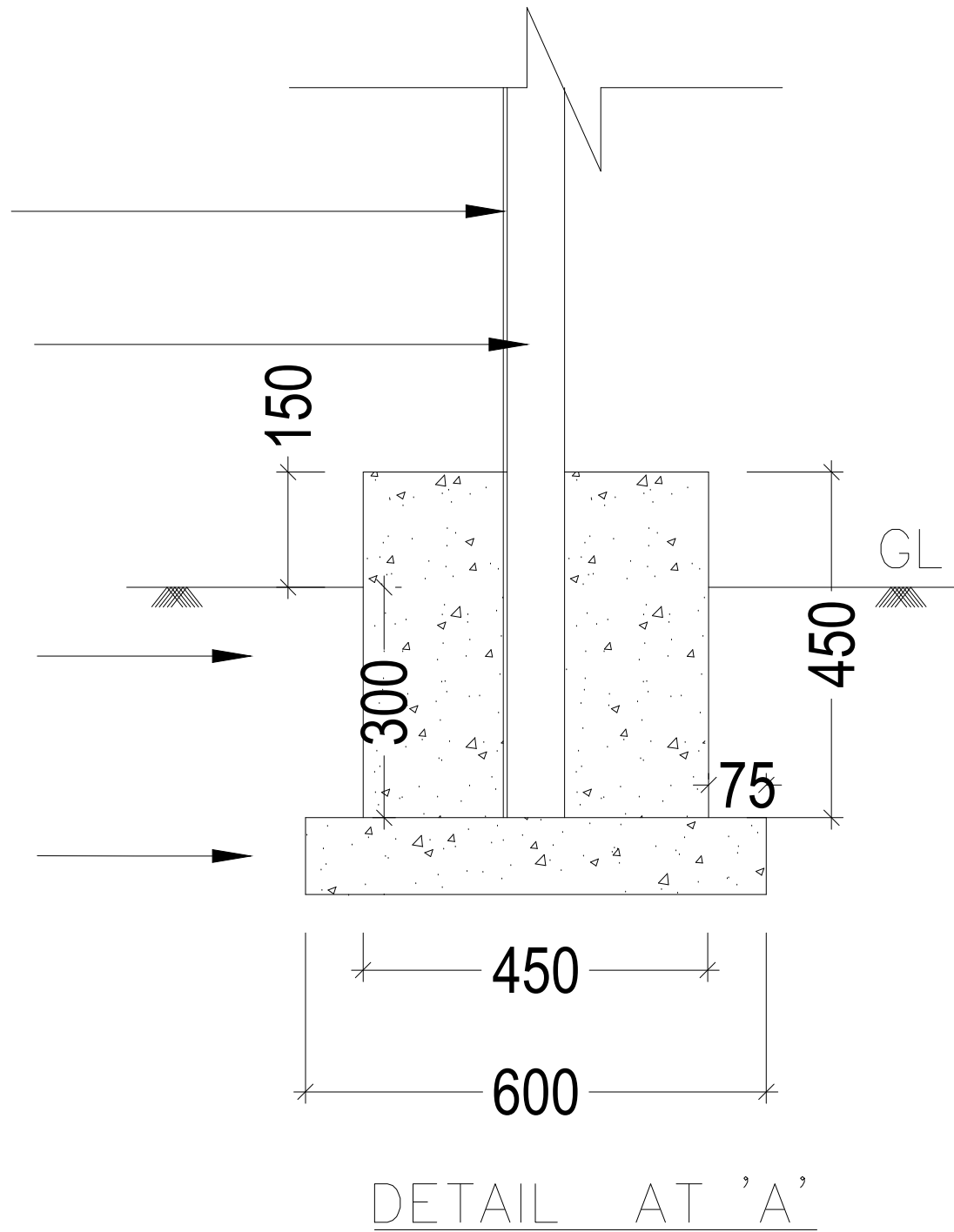

12mm thick plate
welded to frame
and support angle

20mm Bar.
hook welded
on plate

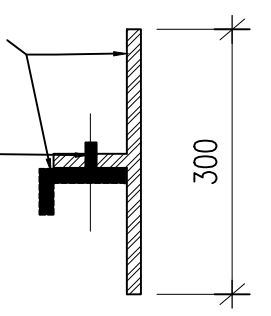

M.S. HOLD FAST

DETAIL AT 'A'

ALL DIMENSIONS ARE IN MILLIMETERS



BHUTAN POWER CORPORATION LIMITED
ENGINEERING & RESEARCH DEPARTMENT

PROJECT:
CONSTRUCTION OF 1250KVA TRANSFORMER FOUNDATION

DRG. No. BPC-DDSC-2023-38(A)

DATE
A4 SIZE
0

DESIGN
& DRAWN
BY:

NAME SIGN

CHECKED
BY:

NAME SIGN

DRAWING TITLE:
GATE

SCALE
NTS
PROJECTION

11kV 750kVA (7T)

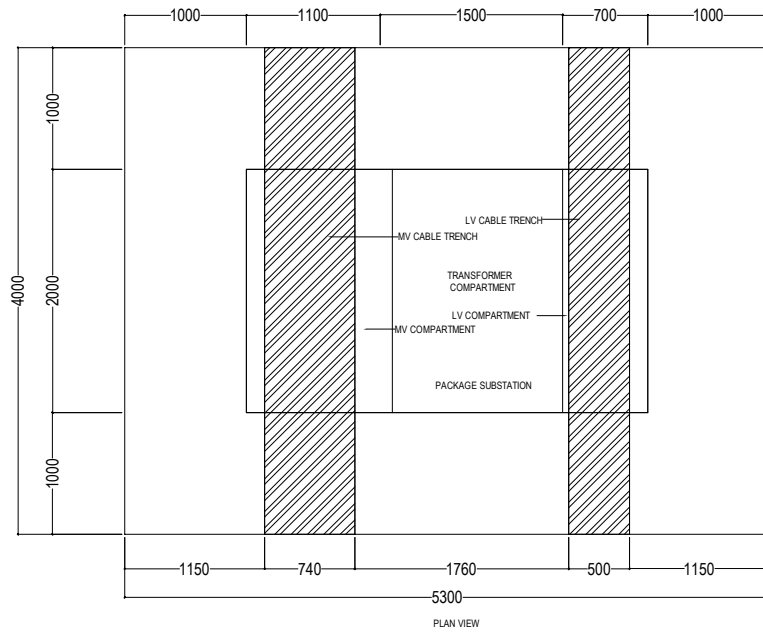

PLAN VIEW

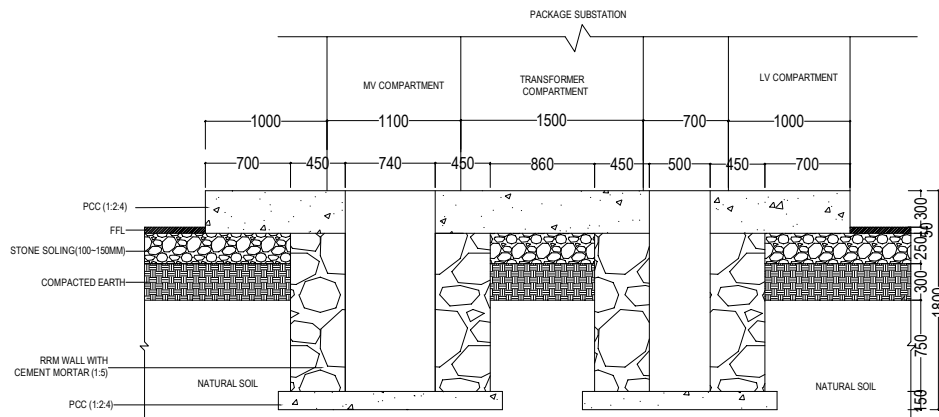

SECTIONAL VIEW

NOTES:-

1. ALL DIMENSIONS SHALL BE IN MM UNLESS OTHERWISE SPECIFIED.
2. SUITABLE CUT OUTS IN TRENCHES FOR CABLE ENTRY/EXIT FROM EQUIPMENT SHALL BE MADE.
3. THE MINIMUM PERMISSIBLE BENDING RADII FOR 33 kV CABLES :- 15D ("D" IS THE OUTER DIAMETER OF THE CABLE) SHALL BE MAINTAINED DURING INSTALLATION.
4. A SLOPE OF 1:100 SHALL BE MAINTAINED ALONG THE RUN OF THE CABLE AND PERPENDICULAR TO THE RUN OF THE CABLE .
5. A PROPER DRAINAGE SHALL BE MAINTAINED AT THE SITE



BHUTAN POWER CORPORATION LIMITED

ENGINEERING AND RESEARCH DEPARTMENT

TITLE : DISTRIBUTION DESIGN & CONSTRUCTION STANDARD

UNITIZED SUBSTATION FOUNDATION - (7TON)

TITLE	NAME	DATE
DESIGNED BY		
CHECKED BY		
APPROVED BY		

DRAWING NO. BPC -DDCS -2020 -37A

**REVISION
2020**

33kV 1250/1000kVA (9T)

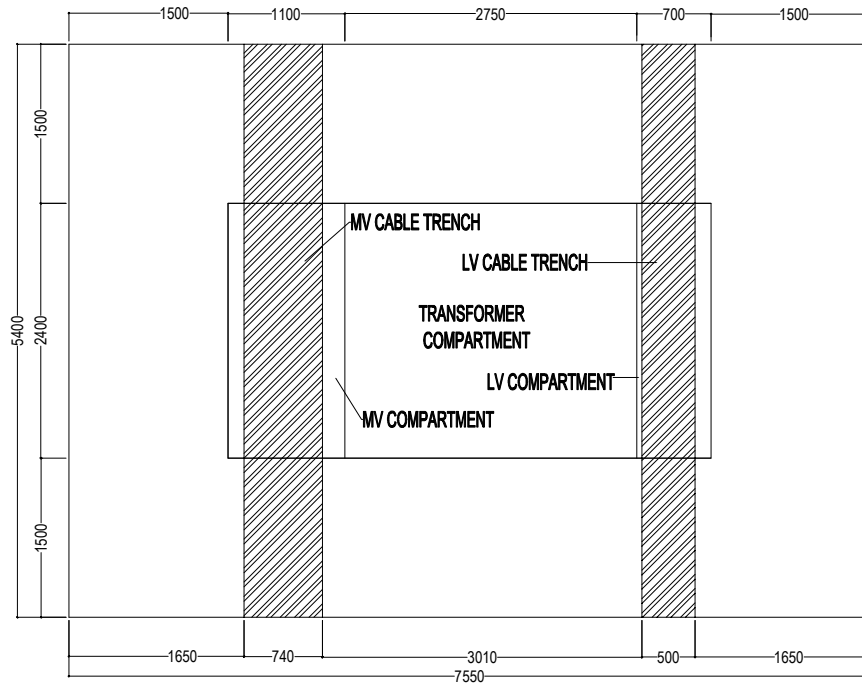

PLAN VIEW

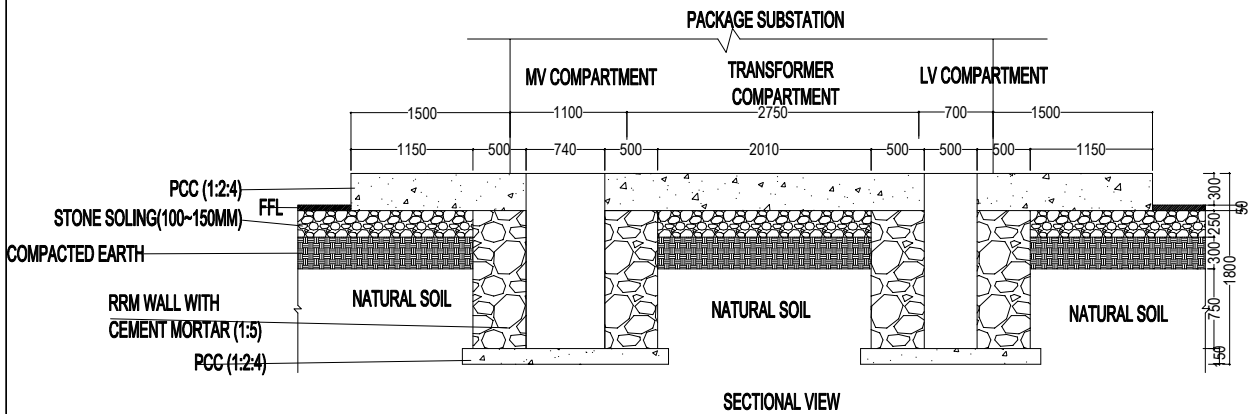

SECTIONAL VIEW

NOTES:-

1. ALL DIMENSIONS SHALL BE IN MM UNLESS OTHERWISE SPECIFIED.
2. SUITABLE CUT OUTS IN TRENCHES FOR CABLE ENTRY/EXIT FROM EQUIPMENT SHALL BE MADE.
3. THE MINIMUM PERMISSIBLE BENDING RADII FOR 33 kV CABLES :- 15D ("D" IS THE OUTER DIAMETER OF THE CABLE) SHALL BE MAINTAINED DURING INSTALLATION.
4. A SLOPE OF 1:100 SHALL BE MAINTAINED ALONG THE RUN OF THE CABLE AND PERPENDICULAR TO THE RUN OF THE CABLE .
5. A PROPER DRAINAGE SHALL BE MAINTAINED AT THE SITE



BHUTAN POWER CORPORATION LIMITED

ENGINEERING AND RESEARCH DEPARTMENT

TITLE : DISTRIBUTION DESIGN & CONSTRUCTION STANDARD

UNITIZED SUBSTATION FOUNDATION (9TON)

TITLE	NAME	DATE
DESIGNED BY		
CHECKED BY		
APPROVED BY		

DRAWING NO. BPC -DDCS -2020 -37B

REVISION
2020

33kV 750kVA (8T)

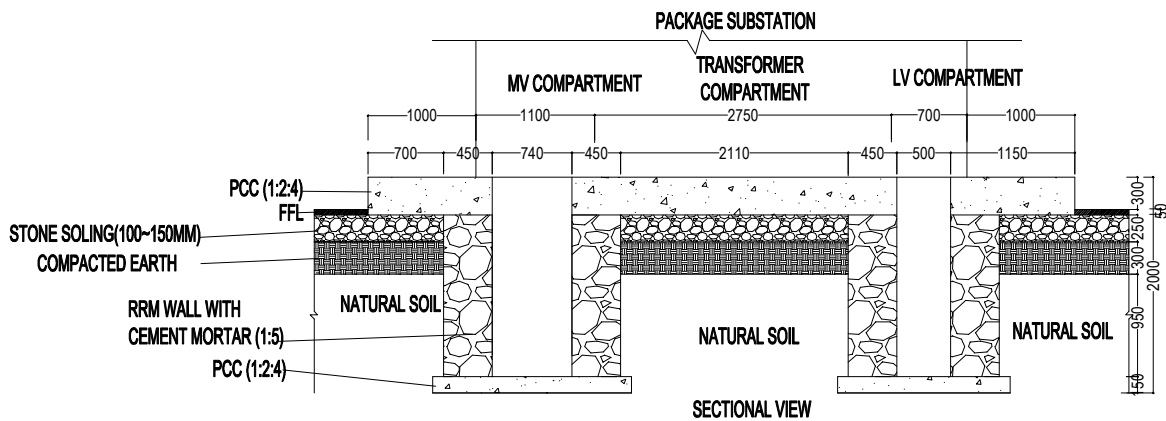
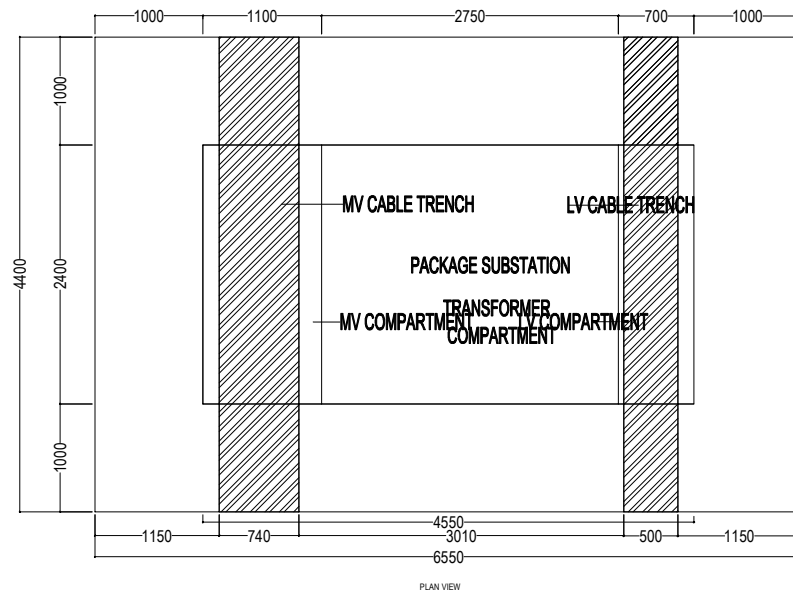

NOTES:-

1. ALL DIMENSIONS SHALL BE IN MM UNLESS OTHERWISE SPECIFIED.
2. SUITABLE CUT OUTS IN TRENCHES FOR CABLE ENTRY/EXIT FROM EQUIPMENT SHALL BE MADE.
3. THE MINIMUM PERMISSIBLE BENDING RADII FOR 33 kV CABLES :- 15D ("D" IS THE OUTER DIAMETER OF THE CABLE) SHALL BE MAINTAINED DURING INSTALLATION.
4. A SLOPE OF 1:100 SHALL BE MAINTAINED ALONG THE RUN OF THE CABLE AND PERPENDICULAR TO THE RUN OF THE CABLE .
5. A PROPER DRAINAGE SHALL BE MAINTAINED AT THE SITE

 <p>BHUTAN POWER CORPORATION LIMITED</p>			ENGINEERING AND RESEARCH DEPARTMENT	
			TITLE : DISTRIBUTION DESIGN & CONSTRUCTION STANDARD	
			UNITIZED SUBSTATION FOUNDATION - (8TON)	
TITLE	NAME	DATE	DRAWING NO. BPC-DDCS-2020-37C REVISION 2020	
DESIGNED BY				
CHECKED BY				
APPROVED BY				

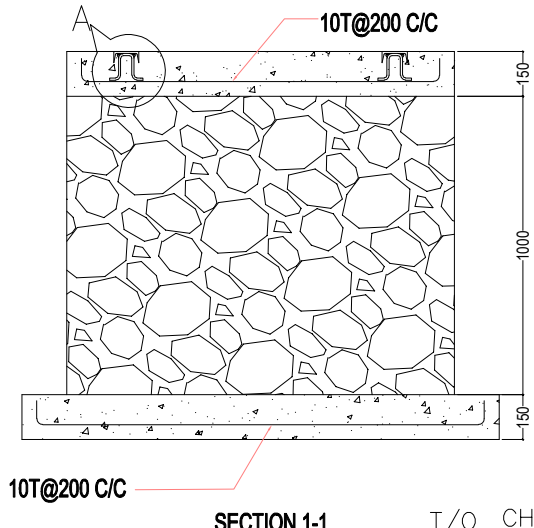

SECTION 1-1

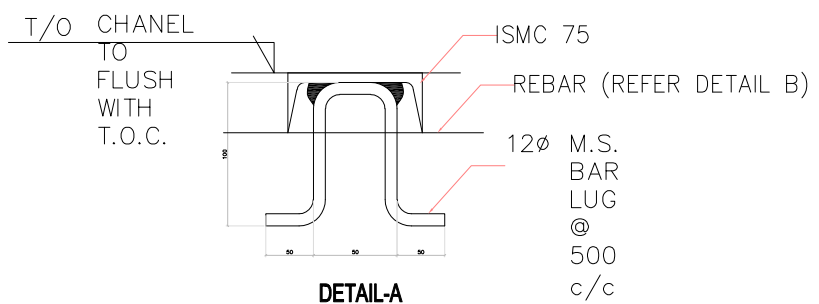

DETAIL-A

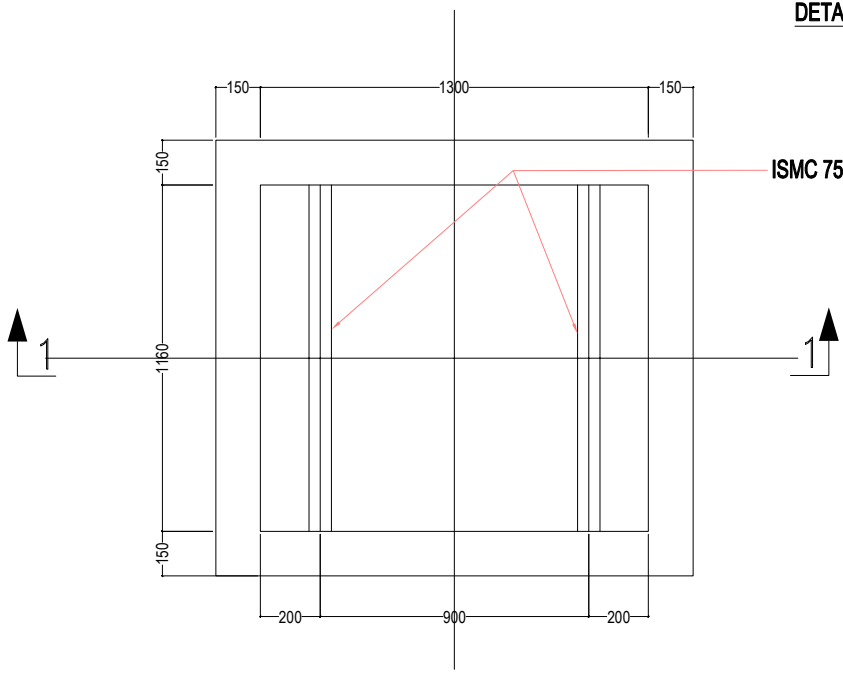

FOUNDATION PLAN



BHUTAN POWER CORPORATION LIMITED

ENGINEERING AND RESEARCH DEPARTMENT

TITLE : DISTRIBUTION DESIGN & CONSTRUCTION STANDARD

TRANSFORMER FOUNDATION UPTO 500kVA - (2.5 TON)

TITLE	NAME	DATE
DESIGNED BY		
CHECKED BY		
APPROVED BY		

DRAWING NO. BPC-DDCS-2020-38	REVISION 2020
------------------------------	------------------

This drawing and design is the property of BPC and must not be passed on to any person who is not authorized by organization nor can be copied or lent without prior permission in writing from the concerned authority.

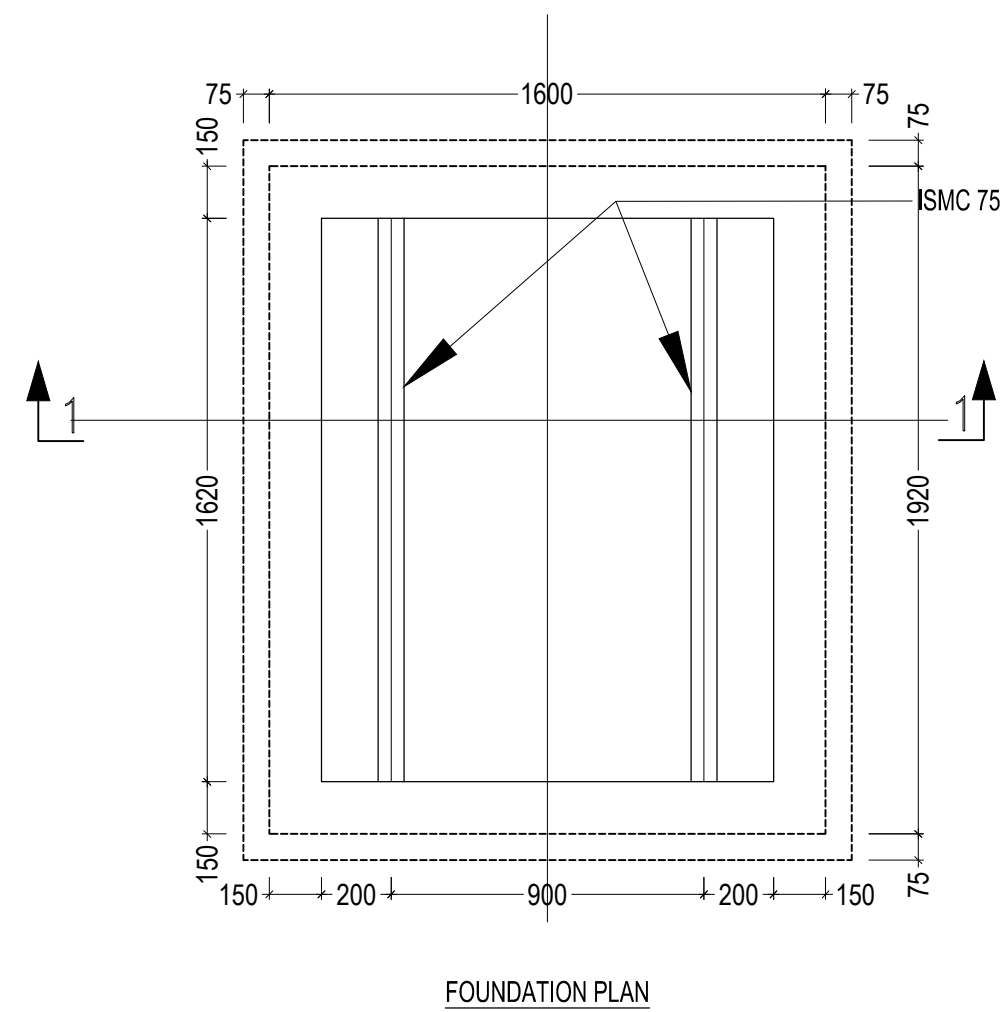
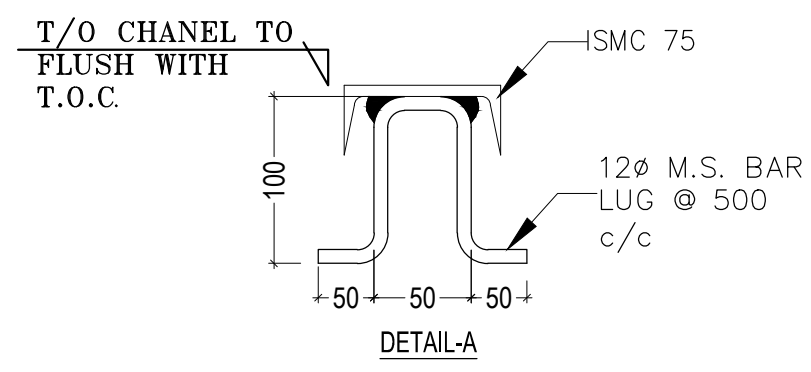
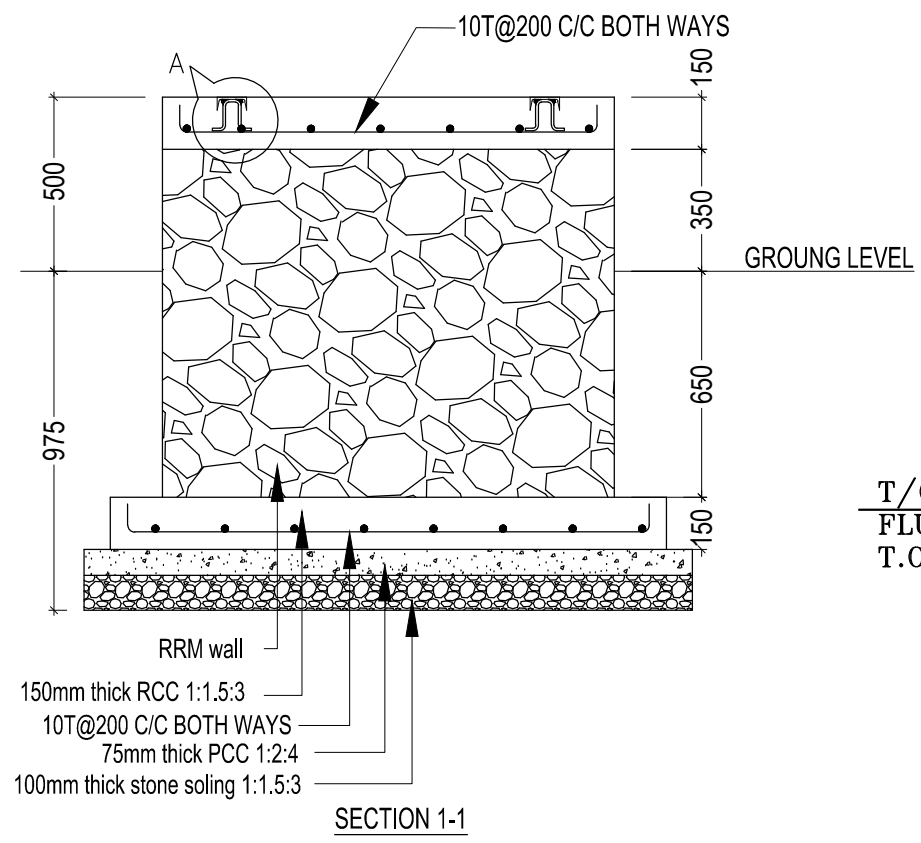

ALL DIMENSIONS ARE IN MILLIMETERS



BHUTAN POWER CORPORATION LIMITED
ENGINEERING & RESEARCH DEPARTMENT

PROJECT:
CONSTRUCTION OF 1250KVA TRANSFORMER FOUNDATION

DRG. No. BPC-DDSC-2023-38(A)

DATE

A4 SIZE 0

REV.

DESIGN & DRAWN BY:

NAME

SIGN

CHECKED BY:

NAME

SIGN

DRAWING TITLE:
1250 KVA TRANSFORMER FOUNDATION

SCALE NTS

PROJECTION

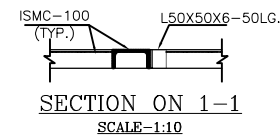
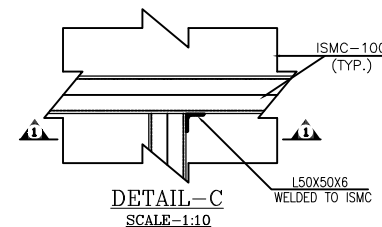
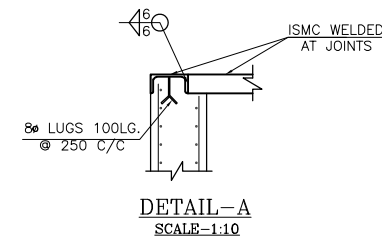
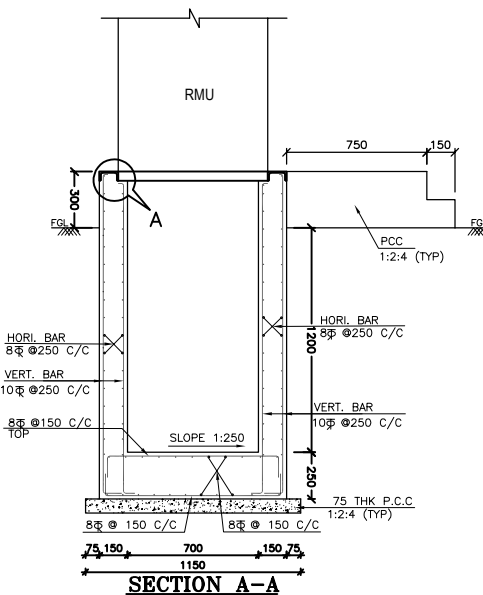
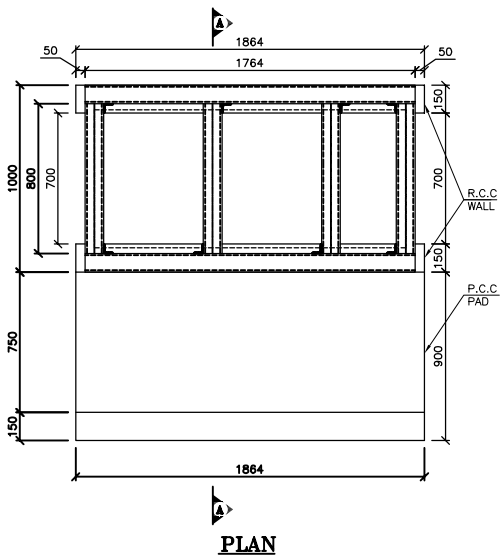
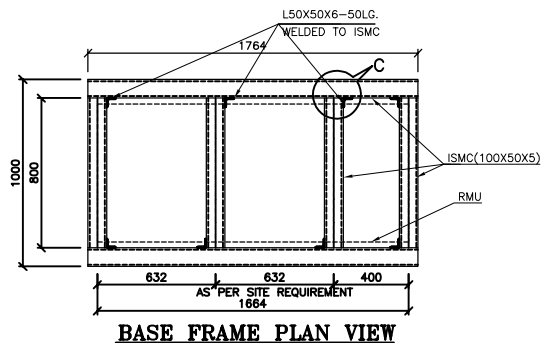

NOTES:-

1. ALL DIMENSIONS SHALL BE IN MM UNLESS OTHERWISE SPECIFIED.
2. SUITABLE CUT OUTS IN TRENCHES FOR CABLE ENTRY/EXIT FROM EQUIPMENT SHALL BE MADE.
3. THE MINIMUM PERMISSIBLE BENDING RADIUS FOR 33 kV CABLES - 15D ("D" IS THE OUTER DIAMETER OF THE CABLE) SHALL BE MAINTAINED DURING INSTALLATION.
4. A SLOPE OF 1:250 SHALL BE MAINTAINED ALONG THE RUN OF THE CABLE AND PERPENDICULAR TO THE RUN OF THE CABLE.
5. DURING RAINFALL, COLLECTED WATER IN THE TRENCH SHOULD BE PUMPED OUT.



BHUTAN POWER CORPORATION LIMITED
CONSTRUCTION & PROCUREMENT DEPARTMENT

TITLE		
CONSTRUCTION OF RMU FOUNDATION		
DRAWING STATUS	APPROVAL	APPROVED

REFERENCE NOTES
1. ALL DIMENSIONS ARE IN MILLIMETERS UNLESS MENTIONED OTHERWISE. 2. THE MEASUREMENTS IN THIS DRAWING ARE TO BE READ AND NOT REVERSED. 3. ANY DISCREPANCY SHOULD BE IMMEDIATELY BROUGHT TO THE NOTICE OF THE RESPONDER. 4. DO NOT ASSUME IF IN DOUBT.

APPROVED BY
<i>[Signature]</i> DORJI KINLEY EXECUTIVE ENGINEER

DESIGNED BY
<i>[Signature]</i> UGYEN PHUNTSHO SENIOR ENGINEER

DRAWING TITLE
RMU FOUNDATION

DRAWING NO	
BPC/C&PD/RMU FDN	
SCALE	DATE
AS STATED	FEBRUARY, 2023

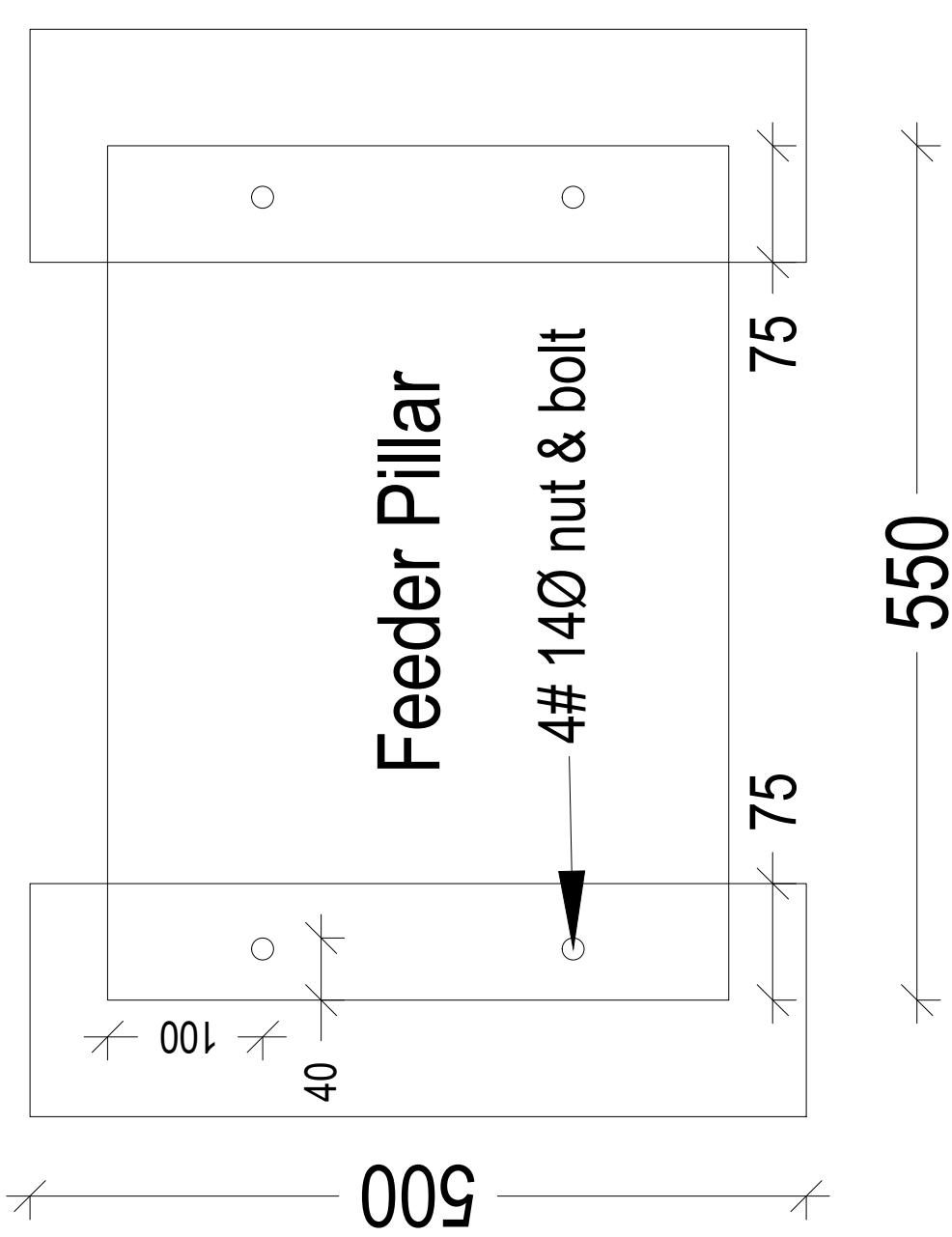

150 400 150

500

400

Feeder Pillar
4# 14Ø nut & bolt

75

75

550

PLAN VIEW

	PROJECT: Power Supply Arrangement to Quarantine Centers Drg. No 01		DATE: 24.03.2022	DESIGN & DRAWN BY: YONTEN JAMTSHO	APPROVED BY:	NAME: YONTEN JAMTSHO	SIGN:	NAME: PUSHPA LAL ACHARYA	SIGN:	DRAWING TITLE: FEEDER PILLAR FOUNDATION	SCALE: N.T.S.	PROJECTION:
	ALL DIMENSIONS ARE IN MILLIMETERS											

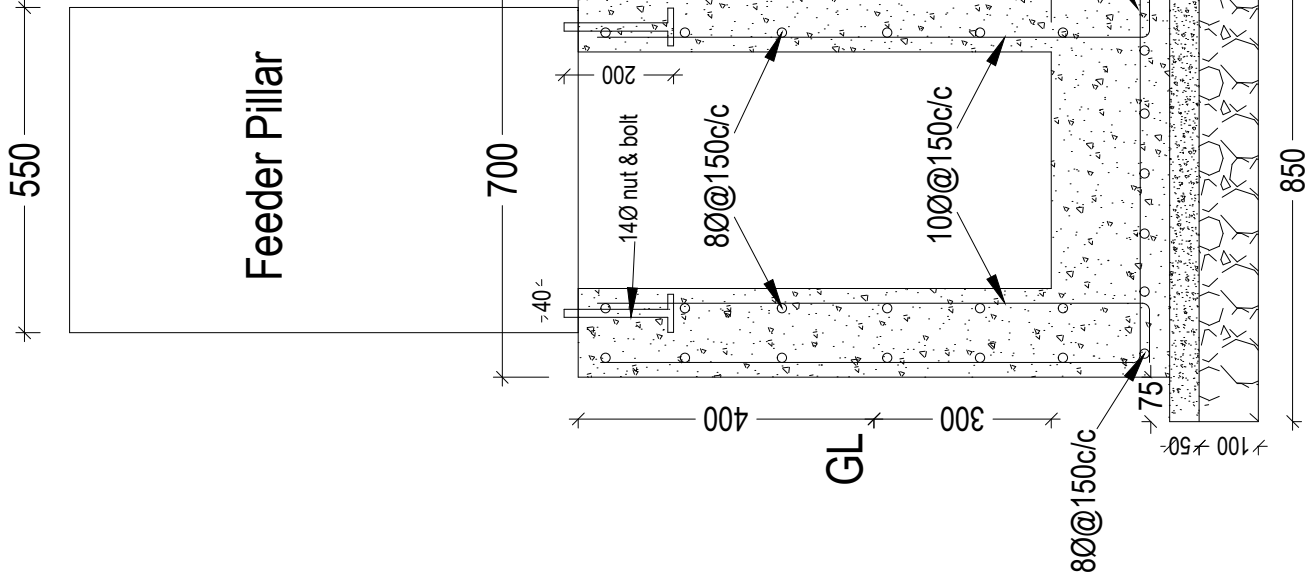

Feeder Pillar

GL

SECTION A-A

	PROJECT: Power Supply Arrangement to Quarantine Centers DRG. No 02		DATE: 24.03.2022	DESIGN & DRAWN BY: YONTEN JAMTSHO	APPROVED BY: PUSHPA LAL ACHARYA	NAME: YONTEN JAMTSHO	NAME: PUSHPA LAL ACHARYA	DRAWING TITLE: FEDDER PILLAR FOUNDATION	SCALE: NTS	PROJECTION:
	ALL DIMENSIONS ARE IN MILLIMETERS									

CIRCULAR ARRANGEMENT

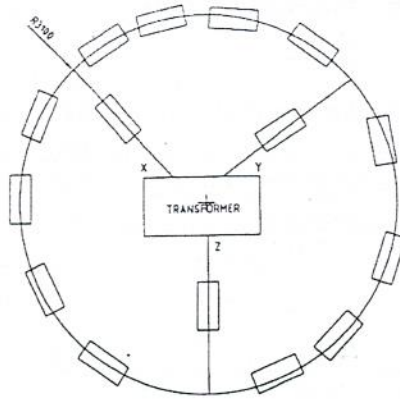

15

RECTANGULAR ARRANGEMENT

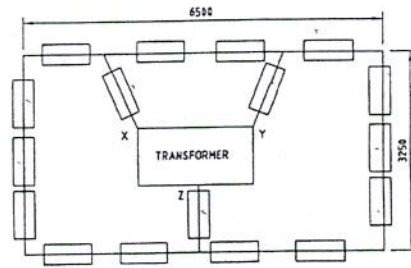

17

TRIANGULAR ARRANGEMENT

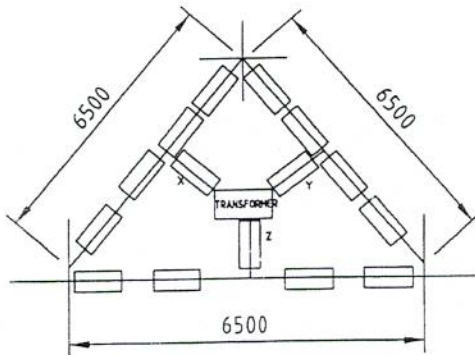

15

NOTES

- THE CONNECTIONS POINTS SHOULD BE AS FOLLOWS:
- a. TO ONE OF THE EARTH POINTS ON EITHER SIDE OF DOUBLE POLE STRUCTURE (X-Y)
 - ONE DIRECT CONNECTION FROM THREE, 33kV OR 11kV LIGHTNING ARRESTERS, AND TRANSFORMER TAP.
 - b. TO EACH OF THE REMAINING TWO EARTH POINTS
 - (i) ONE SEPARATE CONNECTION FROM THE NEUTRAL OF THE LOW VOLTAGE SIDE OF THE TRANSFORMER.
 - (ii) ONE SEPARATE CONNECTION FROM THE TERMINAL OF THE HANDLE OF 33kV/11kV AB SWITCH.
 - (iii) ONE SEPARATE CONNECTION FROM THE EARTH TERMINAL OF THE POLES.
2. 25 x 3 mm GALVANISED IRON STRAP LEADS.
 3. REFER DWG BPC-DDCS-019 FOR EARTH POINTS ON TRANSFORMER AND STRUCTURE.



BHUTAN POWER CORPORATION LIMITED

ENGINEERING DESIGN & CONTRACTS DEPARTMENT

TITLE : DISTRIBUTION DESIGN & CONSTRUCTION STANDARD

INDICATIVE ARRANGEMENT OF GEE SLAB EARTHING DISTRIBUTION SUBSTATION

DESIGNATION	NAME	DATE
DRAFTSPERSON		
DESIGNER		
PROJECT MANAGER		
HEAD OF DEPARTMENT		

DRAWING NO. BPC-DDCS-2014-51B

REVISION 2014